



## UH210

Preliminary

**LINEAR INTEGRATED CIRCUIT**

### 2-PHASE DC MOTOR DRIVE IC

#### ■ DESCRIPTION

The UTC **UH210** is a Latch-Type Hall Effect sensor with built-in complementary output drivers. It's designed with internal temperature compensation circuit, the hysteresis Characteristic is excellent. It has built-in diode prevent reverse power fault and the application is aimed for brush-less DC Fan.

#### ■ FEATURES

- \* On-chip Hall Sensor
- \* Wide Operating Power Range: 2.8V~20V
- \* Excellent Hysteresis Characteristic
- \* Built-in output driver up to 0.45A

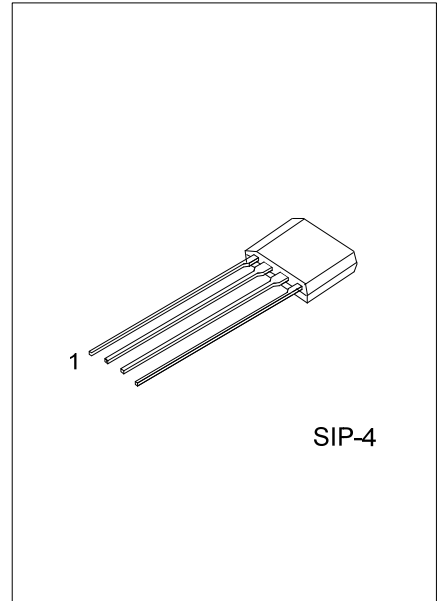

#### ■ ORDERING INFORMATION

Ordering Number		Package	Packing
Lead Free	Halogen Free		
UH210L-G04-K	UH210G-G04-K	SIP-4	Bulk

<p>UH210L-G04-K</p> <p>(1)Packing Type (2)Package Type (3)Lead Free</p>	<p>(1) B: Bulk (2) G04: SIP-4 (3) L: Lead Free, G: Halogen Free</p>
---	---

■ PIN CONFIGURATION

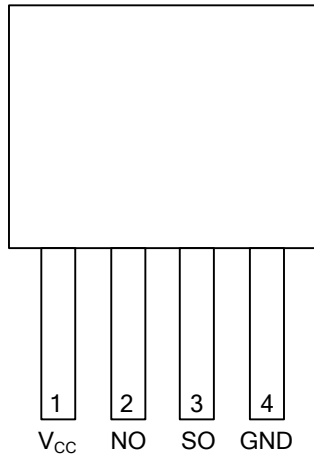

■ PIN DESCRIPTION

PIN NO.	PIN NAME	DESCRIPTION
1	V <sub>CC</sub>	Power Supply
2	NO	Output pin. Low at N magnetic field
3	SO	Output pin. Low at S magnetic field
4	GND	Ground

■ BLOCK DIAGRAM

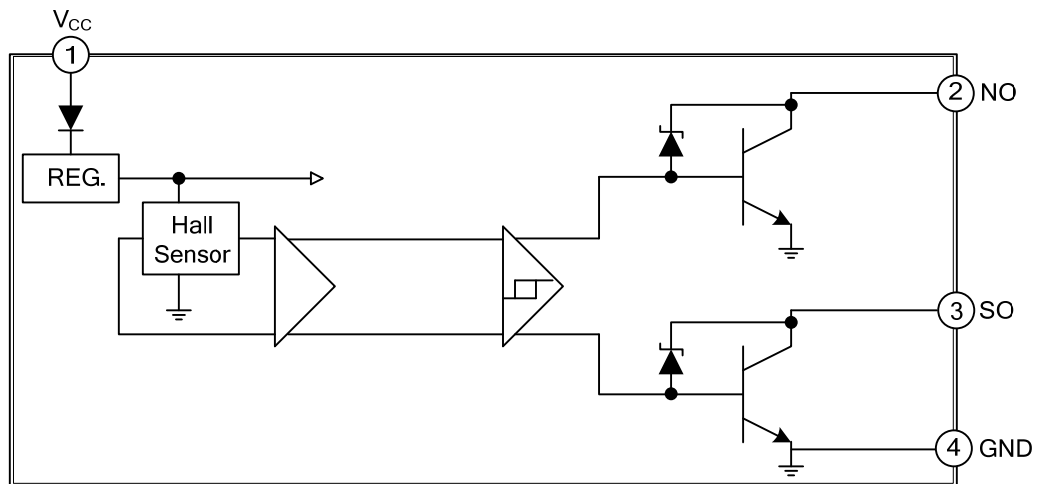

### ■ ABSOLUTE MAXIMUM RATING

PARAMETER		SYMBOL	RATINGS	UNIT
Zener Breakdown Voltage		$V_Z$	35	V
NO/SO Pin Voltage			30	V
VCC Pin Voltage			20	V
Peak Sink Current	Hold Current	$I_O$	700	mA
	Continuous Current	$I_O$	450	mA
Power Dissipation	$T_A=25^\circ\text{C}$	$P_D$	850	mW
	$T_A=85^\circ\text{C}$	$P_D$	450	mW
Thermal Resistance		$\theta_{JA}$	0.15	$^\circ\text{C}/\text{W}$
Operational Temperature Range		$T_{OPR}$	-20~+100	$^\circ\text{C}$
Storage Temperature Range		$T_{STG}$	-65~+150	$^\circ\text{C}$
Junction Temperature		$T_J$	+150	$^\circ\text{C}$
Lead Temperature (Soldering, 10 sec)		$T_L$	+230	$^\circ\text{C}$

Note: Absolute maximum ratings are those values beyond which the device could be permanently damaged. Absolute maximum ratings are stress ratings only and functional device operation is not implied.

### ■ DC ELECTRICAL CHARACTERISTICS

PARAMETER	SYMBOL	TEST CONDITIONS	MIN	TYP	MAX	UNIT
Minimum Operating Voltage	$V_{CC}$	No use pin is open (Fig. 1)		2.8		V
Maximum Operating Voltage	$V_{CC}$	$I_{CC}<20\text{mA}$ No use pin is open (Fig. 1)		20.0		V
Quiescent Supply Current	$I_{CC}$	No use pin is open $V_{CC}: 3.0\text{V}\sim 20\text{V}$ (Fig. 1)		18	20	mA
NO/SO Saturation Voltage	$V_{SAT}$	$I_O=450\text{mA}$ (Fig. 1)			1.0	V

Note: Fig 1 The IC output state is under N magnetic field.

### ■ NO/SO SATURATION VOLTAGE VS. OUTPUT CURRENT ( $I_O$ ) ( $V_{CC}=12\text{V}$ , $T_A=25^\circ\text{C}$ )

PARAMETER	SYMBOL	TEST CONDITIONS	MIN	TYP	MAX	UNIT
Output Saturation Voltage	$V_{O(SAT)}$	$I_{OUT}=200\text{mA}$		0.30		V
		$I_{OUT}=300\text{mA}$		0.47		V
		$I_{OUT}=400\text{mA}$		0.66		V
		$I_{OUT}=500\text{mA}$		0.88		V
		$I_{OUT}=600\text{mA}$		1.09		V
		$I_{OUT}=700\text{mA}$		1.31		V

### ■ AC ELECTRICAL CHARACTERISTICS

PARAMETER	SYMBOL	TEST CONDITIONS	MIN	TYP	MAX	UNIT
Rise Time	$t_R$	$R_L=100\Omega(5\text{W})$ , $C_L=20\text{pF}$ (Fig 1)		10		$\mu\text{s}$
Fall Time	$t_F$	$R_L=100\Omega(5\text{W})$ , $C_L=20\text{pF}$ (Fig 1)		300		nS

### ■ MAGNETIC CHARACTERISTICS ( $T_A=-20\sim 100^\circ\text{C}$ )

#### A grade

PARAMETR	SYMBOL	MIN	TYP	MAX	UNIT
Operate Point	$B_{OP}$	+10		+65	G
Release Point	$B_{RP}$	-65		-10	G
Hysteresis	$B_{HYS}$	20		130	G

#### B grade

PARAMETR	SYMBOL	MIN	TYP	MAX	UNIT
Operate Point	$B_{OP}$	+5		+80	G
Release Point	$B_{RP}$	-80		-5	G
Hysteresis	$B_{HYS}$	10		160	G

■ CHYSTERESIS CHARACTERISTICS

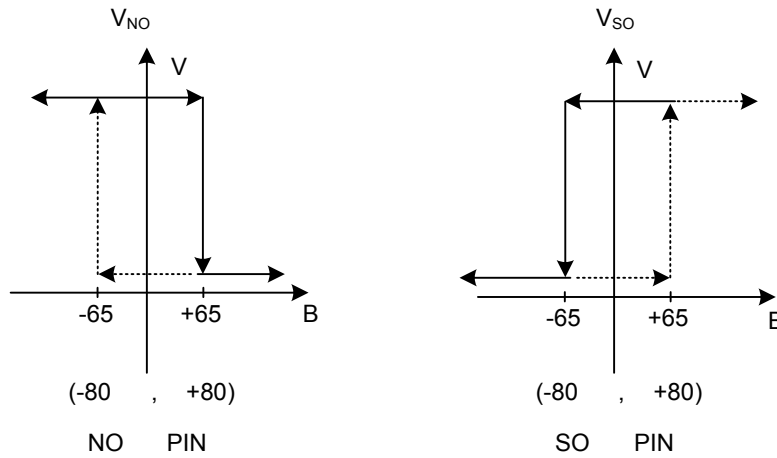

■ TEST CIRCUIT

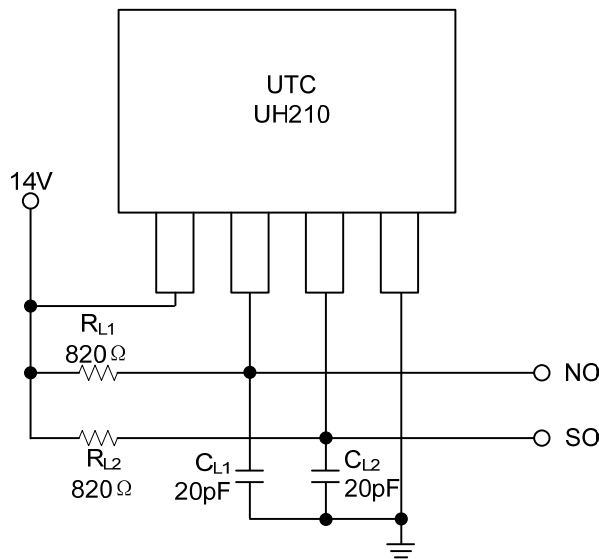
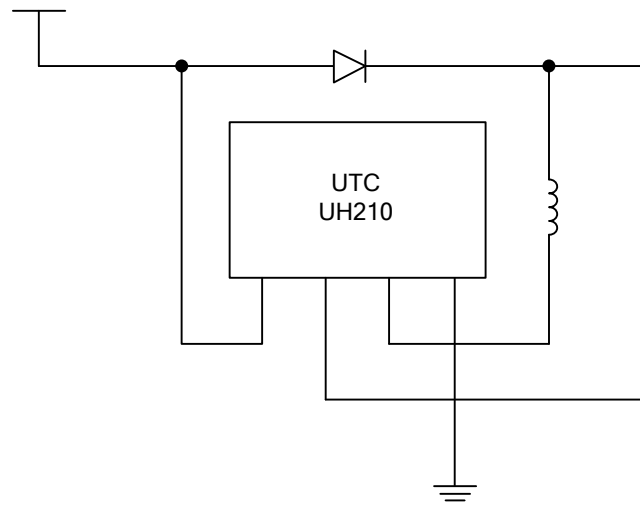

Fig. 1

## ■ TYPICAL APPLICATION CIRCUIT



UTC assumes no responsibility for equipment failures that result from using products at values that exceed, even momentarily, rated values (such as maximum ratings, operating condition ranges, or other parameters) listed in products specifications of any and all UTC products described or contained herein. UTC products are not designed for use in life support appliances, devices or systems where malfunction of these products can be reasonably expected to result in personal injury. Reproduction in whole or in part is prohibited without the prior written consent of the copyright owner. The information presented in this document does not form part of any quotation or contract, is believed to be accurate and reliable and may be changed without notice.