



# KSZ8091MLX

## 10Base-T/100Base-TX Physical Layer Transceiver

Revision 1.2

### General Description

The KSZ8091MLX is a single-supply 10Base-T/100Base-TX Ethernet physical layer transceiver for transmission and reception of data over standard CAT-5 unshielded twisted pair (UTP) cable.

The KSZ8091MLX is a highly-integrated, compact solution. It reduces board cost and simplifies board layout by using on-chip termination resistors for the differential pairs, by integrating a low-noise regulator to supply the 1.2V core, and by offering a flexible 1.8/2.5/3.3V digital I/O interface.

The KSZ8091MLX offers the Media Independent Interface (MII) for direct connection with MII-compliant Ethernet MAC processors and switches.

Energy Efficient Ethernet (EEE) provides further power saving during idle traffic periods and Wake-on-LAN (WOL) provides a mechanism for the KSZ8091MLX to wake up a system that is in standby power mode.

The KSZ8091MLX is available in the 48-pin, lead-free LQFP package (see [Ordering Information](#)).

Datasheets and support documentation are available on website at: [www.micrel.com](http://www.micrel.com).

### Features

- Single-chip 10Base-T/100Base-TX IEEE 802.3 compliant Ethernet transceiver
- MII interface support
- Back-to-back mode support for a 100Mbps copper repeater
- MDC/MDIO management interface for PHY register configuration
- Programmable interrupt output
- LED outputs for link, activity and speed status indication
- On-chip termination resistors for the differential pairs
- Baseline wander correction
- HP Auto MDI/MDI-X to reliably detect and correct straight-through and crossover cable connections with disable and enable option
- Auto-Negotiation to automatically select the highest link-up speed (10/100Mbps) and duplex (half/full)
- Energy Efficient Ethernet (EEE) support with low-power idle (LPI) mode and clock stoppage for 100Base TX and transmit amplitude reduction with 10Base-Te option
- Wake-On-LAN (WOL) support with either magic packet, link status change, or robust custom-packet detection
- LinkMD<sup>®</sup> TDR-based cable diagnostics to identify faulty copper cabling

### Functional Diagram

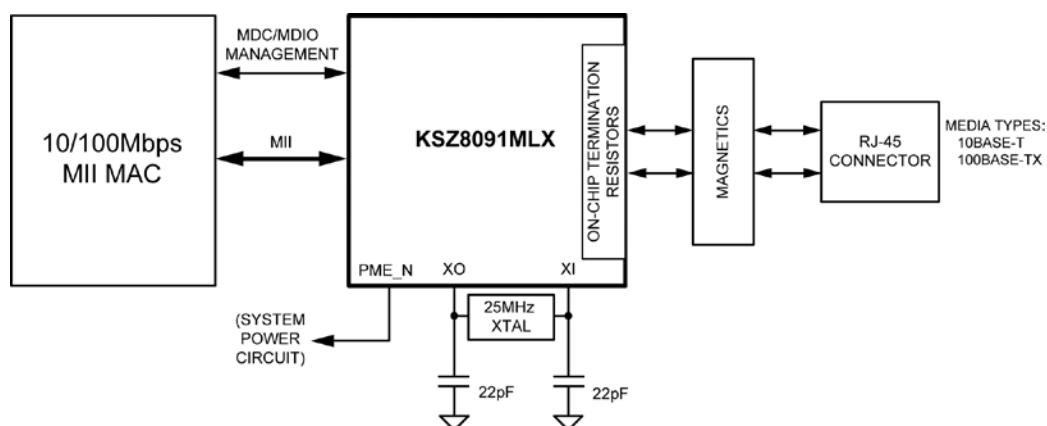

LinkMD is a registered trademark of Micrel, Inc.

Micrel Inc. • 2180 Fortune Drive • San Jose, CA 95131 • USA • tel +1 (408) 944-0800 • fax + 1 (408) 474-1000 • <http://www.micrel.com>

August 31, 2015

Revision 1.2

## Features (Continued)

- HBM ESD rating (6kV)
- Parametric NAND Tree support for fault detection between chip I/Os and the board
- Loopback modes for diagnostics
- Power-down and power-saving modes
- Single 3.3V power supply with VDD I/O options for 1.8V, 2.5V, or 3.3V
- Built-in 1.2V regulator for core
- Available in 48-pin (7mm x 7mm) LQFP package

## Applications

- Game console
- IP phone
- IP set-top box
- IP TV
- LOM
- Printer

## Ordering Information

Ordering Part Number	Temperature Range	Package	Lead Finish	Description
KSZ8091MLXCA	0°C to 70°C	48-Pin LQFP	Pb-Free	MII, EEE and WoL Support, Commercial Temperature.
KSZ8091MLXIA <sup>(1)</sup>	-40°C to 85°C	48-Pin LQFP	Pb-Free	MII, EEE and WoL Support, Industrial Temperature.
KSZ8081MLX-EVAL				KSZ8091MLX Evaluation Board (Mounted with KSZ8091MLX device in commercial temperature)

**Note:**

1. Contact factory for lead time.

## Revision History

Date	Summary of Changes	Revision
1/14/14	New datasheet	1.0
11/25/14	Added silver wire bonding part numbers to Ordering Information. Updated Ordering Information to include Ordering Part Number and Device Marking.	1.1
08/31/15	Add Max frequency for MDC in MII Management (MIIM) Interface section. Updated Table 17 and Table 19. Updated ordering information Table. Updated description and add an equation in LinkMD section. Add a note for table 21. Updated description for Figure 21. Add a note for Figure 22. Add HBM ESD rating in Features.	1.2

## Contents

List of Figures.....	6
List of Tables.....	7
Pin Configuration.....	8
Pin Description.....	9
Strapping Options.....	13
Functional Description: 10Base-T/100Base-TX Transceiver.....	15
100Base-TX Transmit.....	15
100Base-TX Receive.....	15
Scrambler/De-Scrambler (100Base-TX Only).....	15
10Base-T Transmit.....	15
10Base-T Receive.....	16
SQE and Jabber Function (10Base-T Only).....	16
PLL Clock Synthesizer.....	16
Auto-Negotiation.....	16
MII Data Interface.....	18
MII Signal Definition.....	18
Transmit Clock (TXC).....	18
Transmit Enable (TXEN).....	18
Transmit Data[3:0] (TXD[3:0]).....	19
Transmit Error (TXER).....	19
Receive Clock (RXC).....	19
Receive Data Valid (RXDV).....	19
Receive Data[3:0] (RXD[3:0]).....	19
Receive Error (RXER).....	19
Carrier Sense (CRS).....	20
Collision (COL).....	20
MII Signal Diagram.....	20
Back-to-Back Mode – 100Mbps Copper Repeater.....	21
MII Back-to-Back Mode.....	21
MII Management (MIIM) Interface.....	22
Interrupt (INTRP).....	23
HP Auto MDI/MDI-X.....	23
Straight Cable.....	23
Crossover Cable.....	24
Loopback Mode.....	24
Local (Digital) Loopback.....	24
Remote (Analog) Loopback.....	25
LinkMD <sup>®</sup> Cable Diagnostic.....	27
NAND Tree Support.....	27
NAND Tree I/O Testing.....	28
Power Management.....	29
Power-Saving Mode.....	29
Energy-Detect Power-Down Mode.....	29
Power-Down Mode.....	29
Slow-Oscillator Mode.....	29
Efficient Ethernet (EEE).....	30
Transmit Direction Control (MAC-to-PHY).....	30
Receive Direction Control (PHY-to-MAC).....	31
Registers Associated with EEE.....	31

Wake-On-LAN .....	32
Magic-Packet Detection.....	32
Customized-Packet Detection .....	32
Link Status Change Detection .....	33
Reference Circuit for Power and Ground Connections.....	34
Typical Current/Power Consumption .....	35
Transceiver (3.3V), Digital I/Os (3.3V) .....	35
Transceiver (3.3V), Digital I/Os (2.5V) .....	35
Transceiver (3.3V), Digital I/Os (1.8V) .....	36
Register Map .....	37
Standard Registers .....	39
IEEE-Defined Registers – Descriptions.....	39
Vendor-Specific Registers – Descriptions .....	44
MMD Registers.....	49
MMD Registers – Descriptions .....	51
Absolute Maximum Ratings .....	56
Operating Ratings .....	56
Electrical Characteristics.....	56
Timing Diagrams .....	58
MII SQE Timing (10Base-T) .....	58
MII Transmit Timing (10Base-T).....	59
MII Receive Timing (10Base-T).....	60
MII Transmit Timing (100Base-TX) .....	61
MII Receive Timing (100Base-TX) .....	62
Auto-Negotiation Timing .....	63
MDC/MDIO Timing .....	64
Power-Up/Reset Timing .....	65
Reset Circuit.....	66
Reference Circuits – LED Strap-In Pins.....	67
Reference Clock – Connection and Selection .....	68
Magnetic – Connection and Selection .....	69
Package Information and Recommended Land Pattern .....	71

## List of Figures

Figure 1. Auto-Negotiation Flow Chart.....	17
Figure 2. KSZ8091MLX MII Interface .....	20
Figure 3. KSZ8091MLX to KSZ8091MLX Back-to-Back Copper Repeater.....	21
Figure 4. Typical Straight Cable Connection .....	23
Figure 5. Typical Crossover Cable Connection .....	24
Figure 6. Local (Digital) Loopback .....	25
Figure 7. Remote (Analog) Loopback.....	26
Figure 8. LPI Mode (Refresh Transmissions and Quiet Periods) .....	30
Figure 9. LPI Transition – MII (100Mbps) Transmit .....	31
Figure 10. LPI Transition – MII (100Mbps) Receive .....	31
Figure 11. KSZ8091MLX Power and Ground Connections .....	34
Figure 12. MII SQE Timing (10Base-T) .....	58
Figure 13. MII Transmit Timing (10Base-T) .....	59
Figure 14. MII Receive Timing (10Base-T).....	60
Figure 15. MII Transmit Timing (100Base-TX).....	61
Figure 16. MII Receive Timing (100Base-TX).....	62
Figure 17. Auto-Negotiation Fast Link Pulse (FLP) Timing .....	63
Figure 18. MDC/MDIO Timing.....	64
Figure 19. Power-Up/Reset Timing.....	65
Figure 20. Recommended Reset Circuit.....	66
Figure 21. Recommended Reset Circuit for Interfacing with CPU/FPGA Reset Output .....	66
Figure 22. Reference Circuits for LED Strapping Pins .....	67
Figure 23. 25MHz Crystal/Oscillator Reference Clock Connection .....	68
Figure 24. Typical Magnetic Interface Circuit.....	69

## List of Tables

Table 1.	MII Signal Definition .....	18
Table 2.	MII Signal Connection for MII Back-to-Back Mode (100Base-TX Copper Repeater).....	21
Table 3.	MII Management Frame Format for the KSZ8091MLX .....	22
Table 4.	MDI/MDI-X Pin Definition .....	23
Table 5.	NAND Tree Test Pin Order for KSZ8091MLX .....	28
Table 6.	KSZ8091MLX Power Pin Description .....	34
Table 7.	Typical Current/Power Consumption (VDDA_3.3 = 3.3V, VDDIO = 3.3V) .....	35
Table 8.	Typical Current/Power Consumption (VDDA_3.3 = 3.3V, VDDIO = 2.5V) .....	35
Table 9.	Typical Current/Power Consumption (VDDA_3.3 = 3.3V, VDDIO = 1.8V) .....	36
Table 10.	Standard Registers Supported by KSZ8091MLX .....	37
Table 11.	MMD Registers Supported by KSZ8091MLX .....	38
Table 12.	Portal Registers (Access to Indirect MMD Registers).....	49
Table 13.	MII SQE Timing (10Base-T) Parameters .....	58
Table 14.	MII Transmit Timing (10Base-T) Parameters .....	59
Table 15.	MII Receive Timing (10Base-T) Parameters .....	60
Table 16.	MII Transmit Timing (100Base-TX) Parameters .....	61
Table 17.	MII Receive Timing (100Base-TX) Parameters .....	62
Table 18.	Auto-Negotiation Fast Link Pulse (FLP) Timing Parameters .....	63
Table 19.	MDC/MDIO Timing Parameters .....	64
Table 20.	Power-Up/Reset Timing Parameters .....	65
Table 21.	25MHz Crystal / Reference Clock Selection Criteria .....	68
Table 22.	Magnetics Selection Criteria .....	70
Table 23.	Compatible Single-Port 10/100 Magnetics .....	70

## Pin Configuration

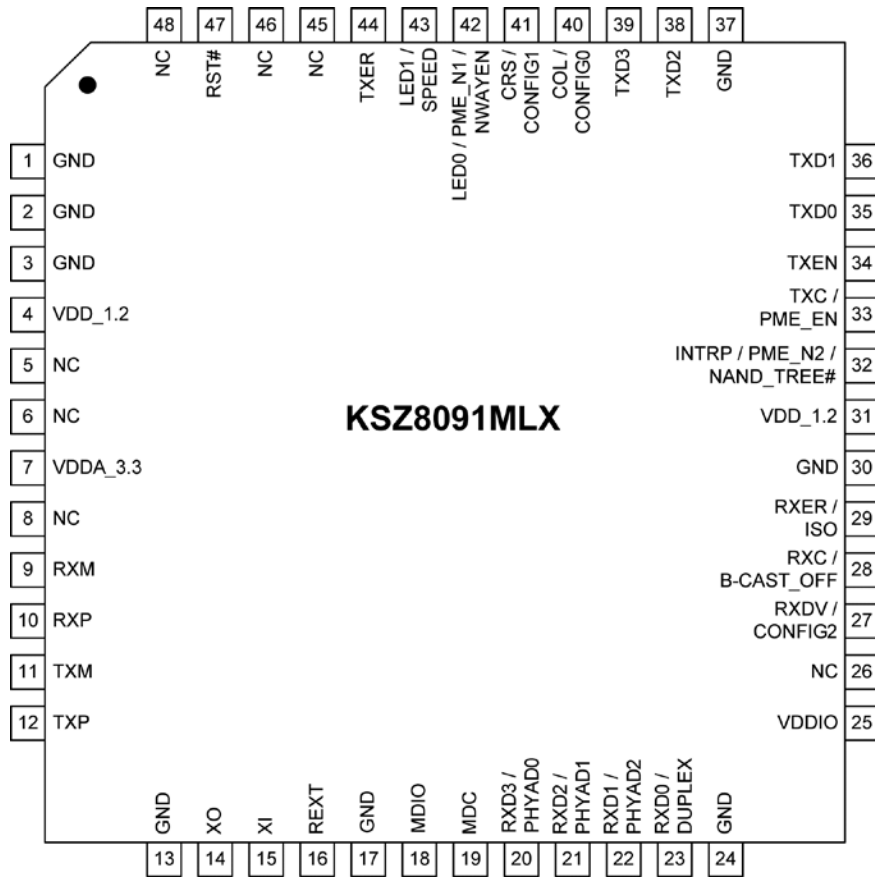

48-Pin 7mm x 7mm LQFP



## Pin Description

Pin Number	Pin Name	Type <sup>(2)</sup>	Pin Function
1	GND	GND	Ground.
2	GND	GND	Ground.
3	GND	GND	Ground.
4	VDD_1.2	P	1.2V core VDD. (Power supplied by KSZ8091MLX.) Decouple with 2.2 $\mu$ F and 0.1 $\mu$ F capacitors to ground, and join with Pin 31 by power trace or plane.
5	NC		No Connect. This pin is not bonded and can be left floating.
6	NC		No Connect. This pin is not bonded and can be left floating.
7	VDDA_3.3	P	3.3V analog V <sub>DD</sub> .
8	NC		No Connect. This pin is not bonded and can be left floating.
9	RXM	I/O	Physical Receive or Transmit Signal (– differential).
10	RXP	I/O	Physical Receive or Transmit Signal (+ differential).
11	TXM	I/O	Physical Transmit or Receive Signal (– differential).
12	TXP	I/O	Physical Transmit or Receive Signal (+ differential).
13	GND	GND	Ground.
14	XO	O	Crystal Feedback for 25MHz Crystal. This pin is a no connect if an oscillator or external clock source is used.
15	XI	I	Crystal / Oscillator / External Clock Input (25MHz $\pm$ 50ppm).
16	REXT	I	Set PHY Transmit Output Current. Connect a 6.49k $\Omega$ resistor to ground on this pin.
17	GND	GND	Ground.
18	MDIO	Ipu/Opu	Management Interface (MII) Data I/O. This pin has a weak pull-up, is open-drain, and requires an external 1.0k $\Omega$ pull-up resistor.
19	MDC	Ipu	Management Interface (MII) Clock Input. This clock pin is synchronous to the MDIO data pin.
20	RXD3/ PHYAD0	Ipu/O	MII mode: MII Receive Data Output[3] <sup>(3)</sup> . Config mode: The pull-up/pull-down value is latched as PHYADDR[0] at the de-assertion of reset. See the Strapping Options section for details.

### Notes:

- P = Power supply.  
GND = Ground.  
I = Input.  
O = Output.  
I/O = Bi-directional.  
Ipu = Input with internal pull-up (see [Electrical Characteristics](#) for value).  
Ipd = Input with internal pull-down (see [Electrical Characteristics](#) for value).  
Ipu/O = Input with internal pull-up (see [Electrical Characteristics](#) for value) during power-up/reset; output pin otherwise.  
Ipd/O = Input with internal pull-down (see [Electrical Characteristics](#) for value) during power-up/reset; output pin otherwise.  
Ipu/Opu = Input with internal pull-up (see [Electrical Characteristics](#) for value) and output with internal pull-up (see [Electrical Characteristics](#) for value).  
Opd = Output with internal pull-down (see [Electrical Characteristics](#) for value).
- MII RX Mode: The RXD[3:0] bits are synchronous with RXC. When RXDV is asserted, RXD[3:0] presents valid data to the MAC.

## Pin Description (Continued)

Pin Number	Pin Name	Type <sup>(2)</sup>	Pin Function
21	RXD2/ PHYAD1	lpd/O	MII Mode: MII Receive Data Output[2] <sup>(3)</sup> . Config. Mode: The pull-up/pull-down value is latched as PHYADDR[1] at the de-assertion of reset. See the <a href="#">Strapping Options</a> section for details.
22	RXD1/ PHYAD2	lpd/O	MII Mode: MII Receive Data Output[1] <sup>(3)</sup> . Config. Mode: The pull-up/pull-down value is latched as PHYADDR[2] at the de-assertion of reset. See the <a href="#">Strapping Options</a> section for details.
23	RXD0/ DUPLEX	lpu/O	MII mode: MII Receive Data Output[0] <sup>(3)</sup> . Config. Mode: The pull-up/pull-down value is latched as DUPLEX at the de-assertion of reset. See the <a href="#">Strapping Options</a> section for details.
24	GND	GND	Ground.
25	VDDIO	P	3.3V, 2.5V, or 1.8V digital V <sub>DD</sub> .
26	NC		No Connect. This pin is not bonded and can be left floating.
27	RXDV/ CONFIG2	lpd/O	MII Mode: MII Receive Data Valid Output Config. Mode: The pull-up/pull-down value is latched as CONFIG2 at the de-assertion of reset. See the <a href="#">Strapping Options</a> section for details.
28	RXC/ B-CAST_OFF	lpd/O	MII mode: MII Receive Clock Output Config mode: The pull-up/pull-down value is latched as B-CAST_OFF at the de-assertion of reset. See the <a href="#">Strapping Options</a> section for details.
29	RXER/ ISO	lpd/O	MII Mode: MII Receive Error Output Config. Mode: The pull-up/pull-down value is latched as ISOLATE at the de-assertion of reset. See the <a href="#">Strapping Options</a> section for details.
30	GND	GND	Ground.
31	VDD_1.2	P	1.2V core V <sub>DD</sub> (power supplied by KSZ8091MLX). Decouple with 0.1µF capacitor to ground, and join with Pin 4 by power trace or plane.
32	INTRP/  PME_N2/ NAND_Tree#	lpu/Opu	Interrupt Output: Programmable interrupt output, with Register 1Bh as the Interrupt Control/Status register, for programming the interrupt conditions and reading the interrupt status. Register 1Fh, Bit [9] sets the interrupt output to active low (default) or active high. PME_N Output: Programmable PME_N output (pin option 2). When asserted low, this pin signals that a WOL event has occurred. Config. Mode: The pull-up/pull-down value is latched as NAND Tree# at the de-assertion of reset. See the <a href="#">Strapping Options</a> section for details. This pin has a weak pull-up and is an open-drain. For Interrupt (when active low) and PME functions, this pin requires an external 1.0kΩ pull-up resistor to VDDIO (digital V <sub>DD</sub> ).
33	TXC/ PME_EN	Opd	MII Mode: MII Transmit Clock Output. Config. Mode: The pull-up/pull-down value is latched as PME_EN at the de-assertion of reset. See the <a href="#">Strapping Options</a> section for details.

## Pin Description (Continued)

Pin Number	Pin Name	Type <sup>(2)</sup>	Pin Function																											
34	TXEN	I	MII Mode: MII Transmit Enable input																											
35	TXD0	I	MII Mode: MII Transmit Data Input[0] <sup>(4)</sup>																											
36	TXD1	I	MII Mode: MII Transmit Data Input[1] <sup>(4)</sup>																											
37	GND	GND	Ground.																											
38	TXD2	I	MII Mode: MII Transmit Data Input[2] <sup>(4)</sup>																											
39	TXD3	I	MII Mode: MII Transmit Data Input[3] <sup>(4)</sup>																											
40	COL/ CONFIG0	lpd/O	MII Mode: MII Collision Detect output Config. Mode: The pull-up/pull-down value is latched as CONFIG0 at the de-assertion of reset. See the <a href="#">Strapping Options</a> section for details.																											
41	CRS/ CONFIG1	lpd/O	MII Mode: MII Carrier Sense output Config. Mode: The pull-up/pull-down value is latched as CONFIG1 at the de-assertion of reset. See the <a href="#">Strapping Options</a> section for details.																											
42	LED0/ PME_N1/  NWAYEN	lpu/O	<p>LED Output: Programmable LED0 Output. PME_N Output: Programmable PME_N Output (pin option 1) In this mode, this pin has a weak pull-up, is an open-drain, and requires an external 1.0kΩ pull-up resistor to VDDIO (digital V<sub>DD</sub>). Config. Mode: Latched as auto-negotiation enable (Register 0h, Bit [12]) at the de-assertion of reset. See the <a href="#">Strapping Options</a> section for details. The LED0 pin is programmable using Register 1Fh, Bits [5:4], and is defined as follows.</p> <table border="1"> <thead> <tr> <th colspan="3">LED Mode = [00]</th> </tr> <tr> <th>Link/Activity</th> <th>Pin State</th> <th>LED Definition</th> </tr> </thead> <tbody> <tr> <td>No Link</td> <td>High</td> <td>OFF</td> </tr> <tr> <td>Link</td> <td>Low</td> <td>ON</td> </tr> <tr> <td>Activity</td> <td>Toggle</td> <td>Blinking</td> </tr> </tbody> </table> <table border="1"> <thead> <tr> <th colspan="3">LED Mode = [01]</th> </tr> <tr> <th>Link</th> <th>Pin State</th> <th>LED Definition</th> </tr> </thead> <tbody> <tr> <td>No Link</td> <td>High</td> <td>OFF</td> </tr> <tr> <td>Link</td> <td>Low</td> <td>ON</td> </tr> </tbody> </table> <p><b>LED Mode = [10], [11] Reserved</b></p>	LED Mode = [00]			Link/Activity	Pin State	LED Definition	No Link	High	OFF	Link	Low	ON	Activity	Toggle	Blinking	LED Mode = [01]			Link	Pin State	LED Definition	No Link	High	OFF	Link	Low	ON
LED Mode = [00]																														
Link/Activity	Pin State	LED Definition																												
No Link	High	OFF																												
Link	Low	ON																												
Activity	Toggle	Blinking																												
LED Mode = [01]																														
Link	Pin State	LED Definition																												
No Link	High	OFF																												
Link	Low	ON																												

**Note:**

4. MII TX Mode: The TXD[3:0] bits are synchronous with TXC. When TXEN is asserted, TXD[3:0] presents valid data from the MAC.

## Pin Description (Continued)

Pin Number	Pin Name	Type <sup>(2)</sup>	Pin Function																								
43	LED1/ SPEED	lpu/O	<p>LED Output: Programmable LED1 output            Config. Mode: Latched as Speed (Register 0h, Bit [13]) at the de-assertion of reset.            See the <a href="#">Strapping Options</a> section for details.            The LED1 pin is programmable using Register 1Fh, Bits [5:4], and is defined as follows.</p> <table border="1"> <thead> <tr> <th colspan="3">LED Mode = [00]</th> </tr> <tr> <th>Speed</th> <th>Pin State</th> <th>LED Definition</th> </tr> </thead> <tbody> <tr> <td>10Base-T</td> <td>High</td> <td>OFF</td> </tr> <tr> <td>100Base-TX</td> <td>Low</td> <td>ON</td> </tr> </tbody> </table> <table border="1"> <thead> <tr> <th colspan="3">LED Mode = [01]</th> </tr> <tr> <th>Activity</th> <th>Pin State</th> <th>LED Definition</th> </tr> </thead> <tbody> <tr> <td>No activity</td> <td>High</td> <td>OFF</td> </tr> <tr> <td>Activity</td> <td>Toggle</td> <td>Blinking</td> </tr> </tbody> </table> <p><b>LED Mode = [10], [11]</b> Reserved</p>	LED Mode = [00]			Speed	Pin State	LED Definition	10Base-T	High	OFF	100Base-TX	Low	ON	LED Mode = [01]			Activity	Pin State	LED Definition	No activity	High	OFF	Activity	Toggle	Blinking
LED Mode = [00]																											
Speed	Pin State	LED Definition																									
10Base-T	High	OFF																									
100Base-TX	Low	ON																									
LED Mode = [01]																											
Activity	Pin State	LED Definition																									
No activity	High	OFF																									
Activity	Toggle	Blinking																									
44	TXER	lpd	<p>MII Mode: MII Transmit Error Input.            For EEE mode, this pin is driven by the EEE-MAC to put the KSZ8091MLX transmit into the LPI state.            For non-EEE mode, this pin is not defined for error transmission from MAC to KSZ8091MLX and can be left as a no connect.</p>																								
45	NC	-	No Connect. This pin is not bonded and can be left floating.																								
46	NC	-	No Connect. This pin is not bonded and can be left floating.																								
47	RST#	lpu	Chip Reset (active low).																								
48	NC	-	No Connect. This pin is not bonded and can be left floating.																								

## Strapping Options

The strap-in pins are latched at the de-assertion of reset. In some systems, the MAC MII receive input pins may drive high/low during power-up or reset, and consequently cause the PHY strap-in pins on the MII signals to be latched to unintended high/low states. In this case, external pull-ups (4.7k $\Omega$ ) or pull-downs (1.0k $\Omega$ ) should be added on these PHY strap-in pins to ensure that the intended values are strapped-in correctly.

Pin Number	Pin Name	Type <sup>(5)</sup>	Pin Function								
22	PHYAD2	lpd/O	PHYAD[2:0] is latched at the de-assertion of reset and is configurable to any value from 0 to 7 with PHY Address 1 as the default value. PHY Address 0 is assigned by default as the broadcast PHY address, but it can be assigned as a unique PHY address after pulling the B-CAST_OFF strapping pin high or writing a '1' to Register 16h, Bit [9]. PHY Address bits [4:3] are set to 00 by default.								
21	PHYAD1	lpd/O									
20	PHYAD0	lpu/O									
27	CONFIG2	lpd/O	The CONFIG[2:0] strap-in pins are latched at the de-assertion of reset.								
41	CONFIG1	lpd/O									
40	CONFIG0	lpd/O									
				<table border="1"> <thead> <tr> <th>CONFIG[2:0]</th> <th>Mode</th> </tr> </thead> <tbody> <tr> <td>000</td> <td>MII (default)</td> </tr> <tr> <td>110</td> <td>MII back-to-back</td> </tr> <tr> <td>001–101, 111</td> <td>Reserved – not used</td> </tr> </tbody> </table>	CONFIG[2:0]	Mode	000	MII (default)	110	MII back-to-back	001–101, 111
CONFIG[2:0]	Mode										
000	MII (default)										
110	MII back-to-back										
001–101, 111	Reserved – not used										
33	PME_EN	Opd	PME output for Wake-On-LAN: Pull-up = Enable Pull-down (default) = Disable At the de-assertion of reset, this pin value is latched into Register 16h, Bit [15].								
29	ISO	lpd/O	Isolate Mode: Pull-up = Enable Pull-down (default) = Disable At the de-assertion of reset, this pin value is latched into Register 0h, Bit [10].								
43	SPEED	lpu/O	Speed Mode: Pull-up (default) = 100Mbps Pull-down = 10Mbps At the de-assertion of reset, this pin value is latched into Register 0h, Bit [13] as the speed select, and also is latched into Register 4h (Auto-Negotiation advertisement) as the speed capability support.								
23	DUPLEX	lpu/O	Duplex Mode: Pull-up (default) = Half-duplex Pull-down = Full-duplex At the de-assertion of reset, this pin value is latched into Register 0h, Bit [8].								
42	NWAYEN	lpu/O	Nway Auto-Negotiation Enable: Pull-up (default) = Enable Auto-Negotiation Pull-down = Disable Auto-Negotiation At the de-assertion of reset, this pin value is latched into Register 0h, Bit [12].								

### Note:

5. lpu/O = Input with internal pull-up (see [Electrical Characteristics](#) for value) during power-up/reset; output pin otherwise.  
lpd/O = Input with internal pull-down (see [Electrical Characteristics](#) for value) during power-up/reset; output pin otherwise.  
lpu/Opu = Input with internal pull-up (see [Electrical Characteristics](#) for value) and output with internal pull-up (see [Electrical Characteristics](#) for value).  
Opd = Output with internal pull-down (see [Electrical Characteristics](#) for value).

**Strapping Options (Continued)**

Pin Number	Pin Name	Type <sup>(5)</sup>	Pin Function
28	B-CAST_OFF	lpd/O	Broadcast Off (for PHY Address 0): Pull-up = PHY Address 0 is set as an unique PHY address Pull-down (default) = PHY Address 0 is set as a broadcast PHY address At the de-assertion of reset, this pin value is latched by the chip.
32	NAND_Tree#	lpu/Opu	NAND Tree Mode: Pull-up (default) = Disable Pull-down = Enable At the de-assertion of reset, this pin value is latched by the chip.

## Functional Description: 10Base-T/100Base-TX Transceiver

The KSZ8091MLX is an integrated single 3.3V supply Fast Ethernet transceiver. It is fully compliant with the IEEE 802.3 Specification, and reduces board cost and simplifies board layout by using on-chip termination resistors for the two differential pairs and by integrating the regulator to supply the 1.2V core.

On the copper media side, the KSZ8091MLX supports 10Base-T and 100Base-TX for transmission and reception of data over a standard CAT-5 unshielded twisted pair (UTP) cable, and HP Auto MDI/MDI-X for reliable detection of and correction for straight-through and crossover cables.

On the MAC processor side, the KSZ8091MLX offers the Media Independent Interface (MII) for direct connection with MII compliant Ethernet MAC processors and switches, respectively.

The MII management bus option gives the MAC processor complete access to the KSZ8091MLX control and status registers. Additionally, an interrupt pin eliminates the need for the processor to poll for PHY status change.

### 100Base-TX Transmit

The 100Base-TX transmit function performs parallel-to-serial conversion, 4B/5B encoding, scrambling, NRZ-to-NRZI conversion, and MLT3 encoding and transmission.

The circuitry starts with a parallel-to-serial conversion, which converts the MII data from the MAC into a 125MHz serial bit stream. The data and control stream is then converted into 4B/5B coding and followed by a scrambler. The serialized data is further converted from NRZ-to-NRZI format, and then transmitted in MLT3 current output. The output current is set by an external 6.49k $\Omega$  1% resistor for the 1:1 transformer ratio.

The output signal has a typical rise/fall time of 4ns and complies with the ANSI TP-PMD standard regarding amplitude balance, overshoot, and timing jitter. The wave-shaped 10Base-T output is also incorporated into the 100Base-TX transmitter.

### 100Base-TX Receive

The 100Base-TX receiver function performs adaptive equalization, DC restoration, MLT3-to-NRZI conversion, data and clock recovery, NRZI-to-NRZ conversion, de-scrambling, 4B/5B decoding, and serial-to-parallel conversion.

The receiving side starts with the equalization filter to compensate for inter-symbol interference (ISI) over the twisted pair cable. Because the amplitude loss and phase distortion is a function of the cable length, the equalizer must adjust its characteristics to optimize performance. In this design, the variable equalizer makes an initial estimation based on comparisons of incoming signal strength against some known cable characteristics, then tunes itself for optimization. This is an ongoing process and self-adjusts against environmental changes such as temperature variations.

Next, the equalized signal goes through a DC-restoration and data-conversion block. The DC-restoration circuit compensates for the effect of baseline wander and improves the dynamic range. The differential data-conversion circuit converts MLT3 format back to NRZI. The slicing threshold is also adaptive.

The clock-recovery circuit extracts the 125MHz clock from the edges of the NRZI signal. This recovered clock is then used to convert the NRZI signal to NRZ format. This signal is sent through the de-scrambler, then the 4B/5B decoder. Finally, the NRZ serial data is converted to MII format and provided as the input data to the MAC.

### Scrambler/De-Scrambler (100Base-TX Only)

The scrambler spreads the power spectrum of the transmitted signal to reduce electromagnetic interference (EMI) and baseline wander. The de-scrambler recovers the scrambled signal.

### 10Base-T Transmit

The 10Base-T drivers are incorporated with the 100Base-TX drivers to allow for transmission using the same magnetic. The drivers perform internal wave-shaping and pre-emphasis, and output 10Base-T signals with typical amplitude of 2.5V peak for standard 10Base-T mode and 1.75V peak for energy-efficient 10Base-Te mode. The 10Base-T/10Base-Te signals have harmonic contents that are at least 27dB below the fundamental frequency when driven by an all-ones Manchester-encoded signal.

### 10Base-T Receive

On the receive side, input buffer and level detecting squelch circuits are used. A differential input receiver circuit and a phase-locked loop (PLL) performs the decoding function. The Manchester-encoded data stream is separated into clock signal and NRZ data. A squelch circuit rejects signals with levels less than 400mV, or with short pulse widths, to prevent noise at the differential line receive inputs from falsely triggering the decoder. When the input exceeds the squelch limit, the PLL locks onto the incoming signal and the KSZ8091MLX decodes a data frame. The receive clock is kept active during idle periods between data receptions.

### SQE and Jabber Function (10Base-T Only)

In 10Base-T operation, a short pulse is put out on the COL pin after each frame is transmitted. This SQE test is needed to test the 10Base-T transmit/receive path. If transmit enable (TXEN) is high for more than 20ms (jabbering), the 10Base-T transmitter is disabled and COL is asserted high. If TXEN is then driven low for more than 250ms, the 10Base-T transmitter is re-enabled and COL is de-asserted (returns to low).

### PLL Clock Synthesizer

The KSZ8091MLX generates all internal clocks and all external clocks for system timing from an external 25MHz crystal, oscillator, or reference clock.

### Auto-Negotiation

The KSZ8091MLX conforms to the auto-negotiation protocol, defined in Clause 28 of the IEEE 802.3 Specification.

Auto-negotiation allows unshielded twisted pair (UTP) link partners to select the highest common mode of operation.

During auto-negotiation, link partners advertise capabilities across the UTP link to each other and then compare their own capabilities with those they received from their link partners. The highest speed and duplex setting that is common to the two link partners is selected as the mode of operation.

The following list shows the speed and duplex operation mode from highest to lowest priority.

- Priority 1: 100Base-TX, full-duplex
- Priority 2: 100Base-TX, half-duplex
- Priority 3: 10Base-T, full-duplex
- Priority 4: 10Base-T, half-duplex

If auto-negotiation is not supported or the KSZ8091MLX link partner is forced to bypass auto-negotiation, then the KSZ8091MLX sets its operating mode by observing the signal at its receiver. This is known as parallel detection, which allows the KSZ8091MLX to establish a link by listening for a fixed signal protocol in the absence of the auto-negotiation advertisement protocol.

Auto-negotiation is enabled by either hardware pin strapping (NWAYEN, Pin 42) or software (Register 0h, Bit [12]).

By default, auto-negotiation is enabled after power-up or hardware reset. After that, auto-negotiation can be enabled or disabled by Register 0h, Bit [12]. If auto-negotiation is disabled, the speed is set by Register 0h, Bit [13], and the duplex is set by Register 0h, Bit [8].

The auto-negotiation link-up process is shown in [Figure 1](#).



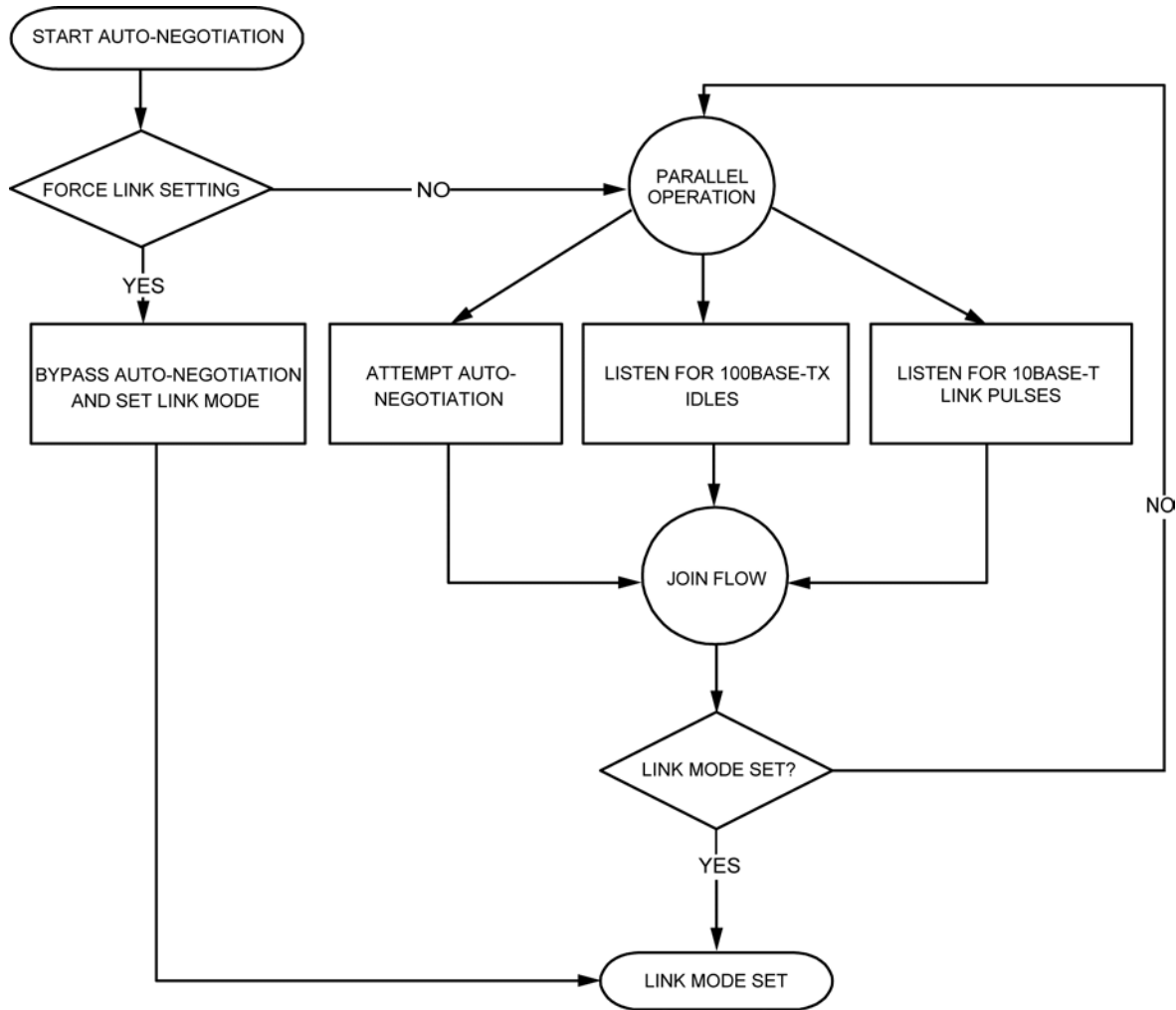

Figure 1. Auto-Negotiation Flow Chart

## MII Data Interface

The Media Independent Interface (MII) is compliant with the IEEE 802.3 Specification. It provides a common interface between MII PHYs and MACs, and has the following key characteristics:

- Pin count is 16 pins (7 pins for data transmission, 7 pins for data reception, and 2 pins for carrier and collision indication).
- 10Mbps and 100Mbps data rates are supported at both half- and full-duplex.
- Data transmission and reception are independent and belong to separate signal groups.
- Transmit data and receive data are each 4 bits wide, a nibble.

By default, the KSZ8091MLX is configured to MII mode after it is powered up or hardware reset with the following:

- A 25MHz crystal connected to XI, XO (Pins 15, 14), or an external 25MHz clock source (oscillator) connected to XI.
- The CONFIG[2:0] strapping pins (Pins 27, 41, 40) set to 000 (default setting).

## MII Signal Definition

Table 1 describes the MII signals. Refer to Clause 22 of the IEEE 802.3 Specification for detailed information.

**Table 1. MII Signal Definition**

MII Signal Name	Direction (with respect to PHY, KSZ8091MLX signal)	Direction (with respect to MAC)	Description
TXC	Output	Input	Transmit Clock (2.5MHz for 10Mbps; 25MHz for 100Mbps)
TXEN	Input	Output	Transmit Enable
TXD[3:0]	Input	Output	Transmit Data[3:0]
TXER	Input	Output, or (not implemented)	Transmit Error (KSZ8091MLX implements only the EEE function for this pin. See “ <a href="#">Transmit Error (TXER)</a> ” for details.)
RXC	Output	Input	Receive Clock (2.5MHz for 10Mbps; 25MHz for 100Mbps)
RXDV	Output	Input	Receive Data Valid
RXD[3:0]	Output	Input	Receive Data[3:0]
RXER	Output	Input, or (not required)	Receive Error
CRS	Output	Input	Carrier Sense
COL	Output	Input	Collision Detection

### **Transmit Clock (TXC)**

TXC is sourced by the PHY. It is a continuous clock that provides the timing reference for TXEN, TXD[3:0] and TXER.

TXC is 2.5MHz for 10Mbps operation and 25MHz for 100Mbps operation.

### **Transmit Enable (TXEN)**

TXEN indicates that the MAC is presenting nibbles on TXD[3:0] for transmission. It is asserted synchronously with the first nibble of the preamble and remains asserted while all nibbles to be transmitted are presented on the MII. It is negated before the first TXC following the final nibble of a frame.

TXEN transitions synchronously with respect to TXC.

**Transmit Data[3:0] (TXD[3:0])**

When TXEN is asserted, TXD[3:0] are the data nibbles presented by the MAC and accepted by the PHY for transmission.

When TXEN is de-asserted, the MAC drives TXD[3:0] to either 0000 for the idle state (non-EEE mode) or 0001 for the LPI state (EEE mode).

TXD[3:0] transitions synchronously with respect to TXC.

**Transmit Error (TXER)**

TXER is implemented only for the EEE function.

For EEE mode, this pin is driven by the EEE-MAC to put the KSZ8091MLX transmit into the LPI state.

For non-EEE mode, this pin is not defined for error transmission from MAC to KSZ8091MLX and can be left as a no connect.

TXER transitions synchronously with respect to TXC.

**Receive Clock (RXC)**

RXC provides the timing reference for RXDV, RXD[3:0] and RXER.

- In 10Mbps mode, RXC is recovered from the line while the carrier is active. When the line is idle or the link is down, RXC is derived from the PHY's reference clock.
- In 100Mbps mode, RXC is recovered continuously from the line. If the link is down, RXC is derived from the PHY's reference clock.

RXC is 2.5MHz for 10Mbps operation and 25MHz for 100Mbps operation.

**Receive Data Valid (RXDV)**

RXDV is driven by the PHY to indicate that the PHY is presenting recovered and decoded nibbles on RXD[3:0].

- In 10Mbps mode, RXDV is asserted with the first nibble of the start-of-frame delimiter (SFD), 5D, and remains asserted until the end of the frame.
- In 100Mbps mode, RXDV is asserted from the first nibble of the preamble to the last nibble of the frame.

RXDV transitions synchronously with respect to RXC.

**Receive Data[3:0] (RXD[3:0])**

For each clock period in which RXDV is asserted, RXD[3:0] transfers a nibble of recovered data from the PHY.

When RXDV is de-asserted, the PHY drives RXD[3:0] to either 0000 for the idle state (non-EEE mode) or 0001 for the LPI state (EEE mode).

RXD[3:0] transitions synchronously with respect to RXC.

**Receive Error (RXER)**

When RXDV is asserted, RXER is asserted for one or more RXC periods to indicate that a symbol error (for example, a coding error that a PHY can detect that may otherwise be undetectable by the MAC sub-layer) is detected somewhere in the frame that is being transferred from the PHY to the MAC.

In EEE mode only, when RXDV is de-asserted, RXER is driven by the PHY to inform the MAC that the KSZ8091MLX receive is in the LPI state.

RXER transitions synchronously with respect to RXC.

**Carrier Sense (CRS)**

CRS is asserted and de-asserted as follows:

- In 10Mbps mode, CRS assertion is based on the reception of valid preambles. CRS de-assertion is based on the reception of an end-of-frame (EOF) marker.
- In 100Mbps mode, CRS is asserted when a start-of-stream delimiter or /J/K symbol pair is detected. CRS is de-asserted when an end-of-stream delimiter or /T/R symbol pair is detected. Additionally, the PMA layer de-asserts CRS if IDLE symbols are received without /T/R.

**Collision (COL)**

COL is asserted in half-duplex mode whenever the transmitter and receiver are simultaneously active on the line. This informs the MAC that a collision has occurred during its transmission to the PHY.

COL transitions asynchronously with respect to TXC and RXC.

**MII Signal Diagram**

The KSZ8091MLX MII pin connections to the MAC are shown in [Figure 2](#).

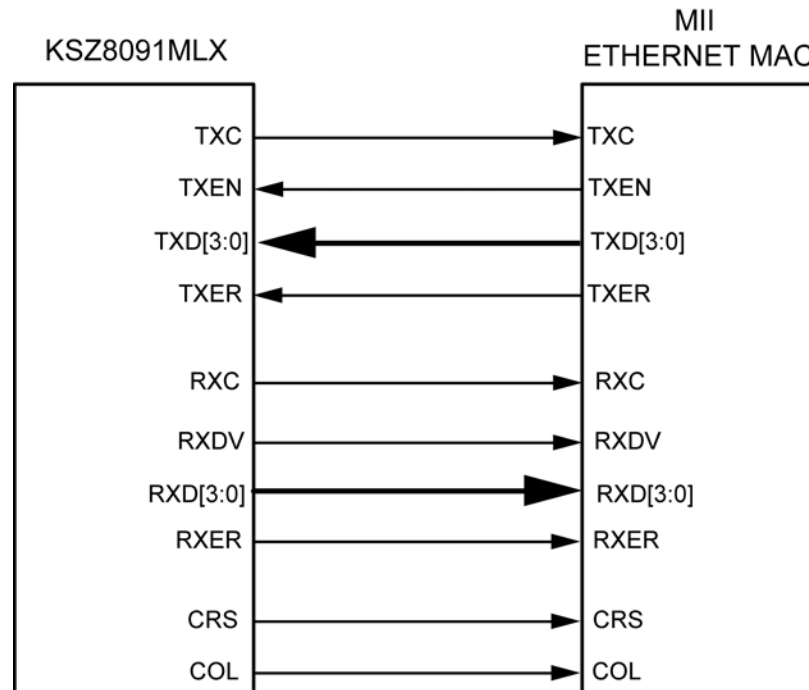

Figure 2. KSZ8091MLX MII Interface

## Back-to-Back Mode – 100Mbps Copper Repeater

Two KSZ8091MLX devices can be connected back-to-back to form a 100Base-TX copper repeater.

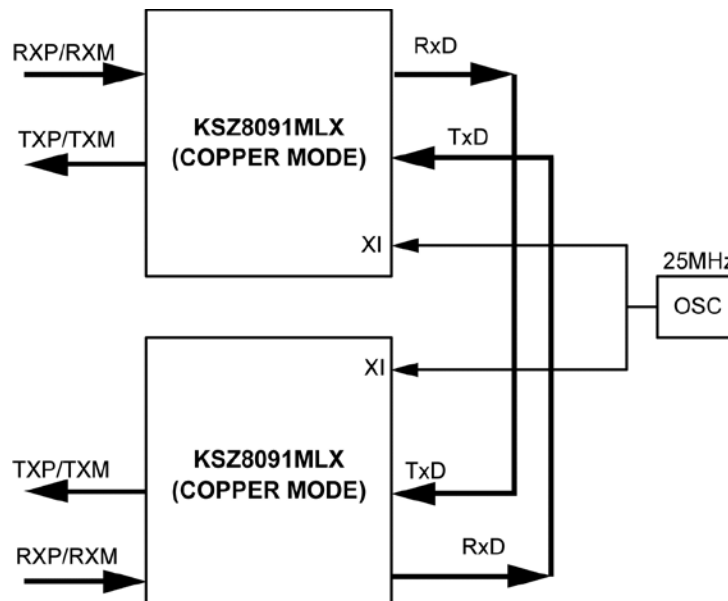

Figure 3. KSZ8091MLX to KSZ8091MLX Back-to-Back Copper Repeater

### MII Back-to-Back Mode

In MII back-to-back mode, a KSZ8091MLX interfaces with another KSZ8091MLX to provide a complete 100Mbps copper repeater solution.

The KSZ8091MLX devices are configured to MII back-to-back mode after power-up or reset with the following:

- Strapping pin CONFIG[2:0] (Pins 27, 41, 40) set to 110
- A common 25MHz reference clock connected to XI (Pin 15) of both KSZ8091MLX devices
- MII signals connected as shown in [Table 2](#)

Table 2. MII Signal Connection for MII Back-to-Back Mode (100Base-TX Copper Repeater)

KSZ8091MLX (100Base-TX copper) [Device 1]			KSZ8091MLX (100Base-TX copper) [Device 2]		
Pin Name	Pin Number	Pin Type	Pin Name	Pin Number	Pin Type
RXDV	27	Output	TXEN	34	Input
RXD3	20	Output	TXD3	39	Input
RXD2	21	Output	TXD2	38	Input
RXD1	22	Output	TXD1	36	Input
RXD0	23	Output	TXD0	35	Input
TXEN	34	Input	RXDV	27	Output
TXD3	39	Input	RXD3	20	Output
TXD2	38	Input	RXD2	21	Output
TXD1	36	Input	RXD1	22	Output
TXD0	35	Input	RXD0	23	Output

## MII Management (MIIM) Interface

The KSZ8091MLX supports the IEEE 802.3 MII management interface, also known as the Management Data Input/Output (MDIO) interface. This interface allows an upper-layer device, such as a MAC processor, to monitor and control the state of the KSZ8091MLX. An external device with MIIM capability is used to read the PHY status and/or configure the PHY settings. More details about the MIIM interface can be found in Clause 22.2.4 of the IEEE 802.3 Specification.

The MIIM interface consists of the following:

- A physical connection that incorporates the clock line (MDC) and the data line (MDIO).
- A specific protocol that operates across the physical connection mentioned earlier, which allows the external controller to communicate with one or more PHY devices.
- A 32-register address space for direct access to IEEE-defined registers and vendor-specific registers, and for indirect access to MMD addresses and registers. See the [Register Map](#) section.

As the default, the KSZ8091MLX supports unique PHY Addresses 1 to 7, and broadcast PHY Address 0. The latter is defined in the IEEE 802.3 Specification, and can be used to read/write to a single KSZ8091MLX device, or write to multiple KSZ8091MLX devices simultaneously.

PHY Address 0 can optionally be disabled as the broadcast address by either hardware pin strapping (B-CAST\_OFF, Pin 28) or software (Register 16h, Bit [9]), and assigned as a unique PHY address.

The PHYAD[2:0] strapping pins are used to assign a unique PHY address between 0 and 7 to each KSZ8091MLX device.

The MIIM interface can operate up to a maximum clock speed of 10MHz MAC clock.

[Table 3](#) shows the MII management frame format for the KSZ8091MLX.

**Table 3. MII Management Frame Format for the KSZ8091MLX**

	Preamble	Start of Frame	Read/Write OP Code	PHY Address Bits [4:0]	REG Address Bits [4:0]	TA	Data Bits [15:0]	Idle
<b>Read</b>	32 1's	01	10	00AAA	RRRRR	Z0	DDDDDDDD_DDDDDDDD	Z
<b>Write</b>	32 1's	01	01	00AAA	RRRRR	10	DDDDDDDD_DDDDDDDD	Z

## Interrupt (INTRP)

INTRP (Pin 32) is an optional interrupt signal that is used to inform the external controller that there has been a status update to the KSZ8091MLX PHY Register. Bits [15:8] of Register 1Bh are the interrupt control bits to enable and disable the conditions for asserting the INTRP signal. Bits [7:0] of Register 1Bh are the interrupt status bits to indicate which interrupt conditions have occurred. The interrupt status bits are cleared after reading Register 1Bh.

Bit [9] of Register 1Fh sets the interrupt level to active high or active low. The default is active low.

The MII management bus option gives the MAC processor complete access to the KSZ8091MLX control and status registers. Additionally, an interrupt pin eliminates the need for the processor to poll the PHY for status change.

## HP Auto MDI/MDI-X

HP Auto MDI/MDI-X configuration eliminates the need to decide whether to use a straight cable or a crossover cable between the KSZ8091MLX and its link partner. This feature allows the KSZ8091MLX to use either type of cable to connect with a link partner that is in either MDI or MDI-X mode. The auto-sense function detects transmit and receive pairs from the link partner and assigns transmit and receive pairs to the KSZ8091MLX accordingly.

HP Auto MDI/MDI-X is enabled by default. It is disabled by writing a '1' to Register 1Fh, Bit [13]. MDI and MDI-X mode is selected by Register 1Fh, Bit [14] if HP Auto MDI/MDI-X is disabled.

An isolation transformer with symmetrical transmit and receive data paths is recommended to support Auto MDI/MDI-X.

Table 4 shows how the IEEE 802.3 Standard defines MDI and MDI-X.

**Table 4. MDI/MDI-X Pin Definition**

MDI		MDI-X	
RJ-45 Pin	Signal	RJ-45 Pin	Signal
1	TX+	1	RX+
2	TX-	2	RX-
3	RX+	3	TX+
6	RX-	6	TX-

## Straight Cable

A straight cable connects an MDI device to an MDI-X device, or an MDI-X device to an MDI device. Figure 4 shows a typical straight cable connection between a NIC card (MDI device) and a switch or hub (MDI-X device).

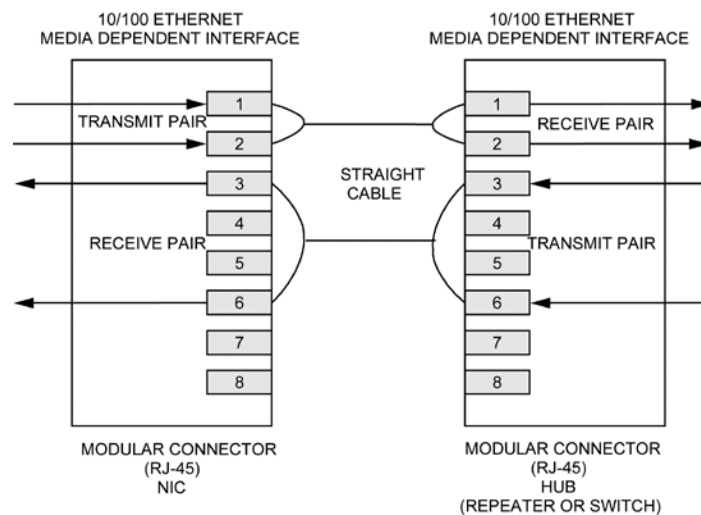

**Figure 4. Typical Straight Cable Connection**

## Crossover Cable

A crossover cable connects an MDI device to another MDI device, or an MDI-X device to another MDI-X device. [Figure 5](#) shows a typical crossover cable connection between two switches or hubs (two MDI-X devices).

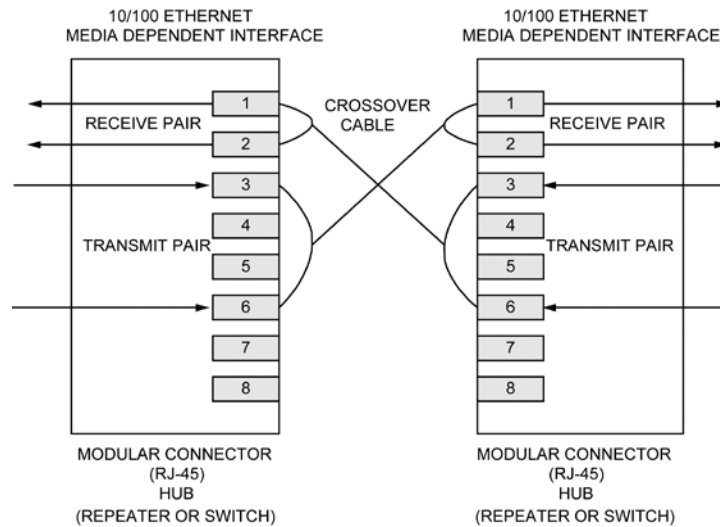

**Figure 5. Typical Crossover Cable Connection**

## Loopback Mode

The KSZ8091MLX supports the following loopback operations to verify analog and/or digital data paths.

- Local (digital) loopback
- Remote (analog) loopback

### Local (Digital) Loopback

This loopback mode checks the MII transmit and receive data paths between the KSZ8091MLX and the external MAC, and is supported for both speeds (10/100Mbps) at full-duplex.

The loopback data path is shown in [Figure 6](#).

1. The MII MAC transmits frames to the KSZ8091MLX.
2. Frames are wrapped around inside the KSZ8091MLX.
3. The KSZ8091MLX transmits frames back to the MII MAC.



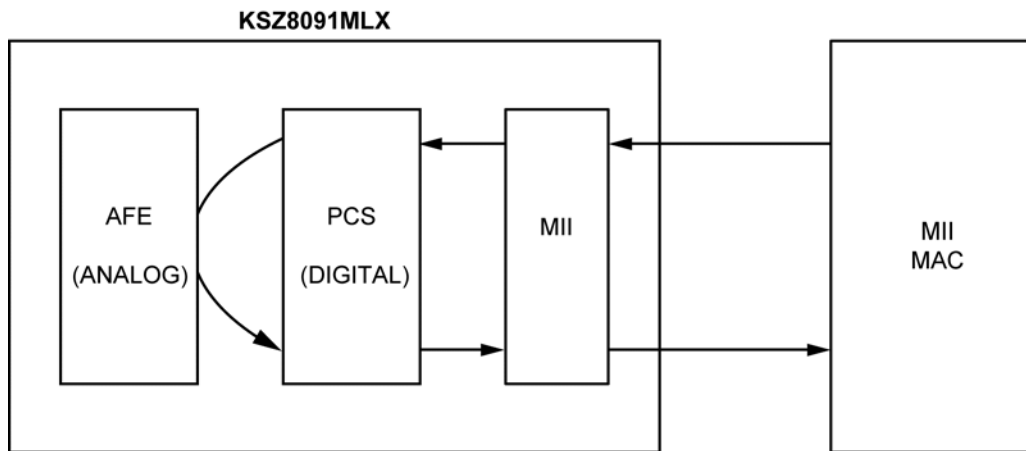

**Figure 6. Local (Digital) Loopback**

The following programming action and register settings are used for local loopback mode:

For 10/100Mbps loopback,

Set Register 0h,

Bit [14] = 1 // Enable local loopback mode

Bit [13] = 0/1 // Select 10Mbps/100Mbps speed

Bit [12] = 0 // Disable Auto-Negotiation

Bit [8] = 1 // Select full-duplex mode

### Remote (Analog) Loopback

This loopback mode checks the line (differential pairs, transformer, RJ-45 connector, Ethernet cable) transmit and receive data paths between the KSZ8091MLX and its link partner, and is supported for 100Base-TX full-duplex mode only.

The loopback data path is shown in [Figure 7](#):

1. The Fast Ethernet (100Base-TX) PHY link partner transmits frames to the KSZ8091MLX.
2. Frames are wrapped around inside the KSZ8091MLX.
3. The KSZ8091MLX transmits frames back to the Fast Ethernet (100Base-TX) PHY link partner.

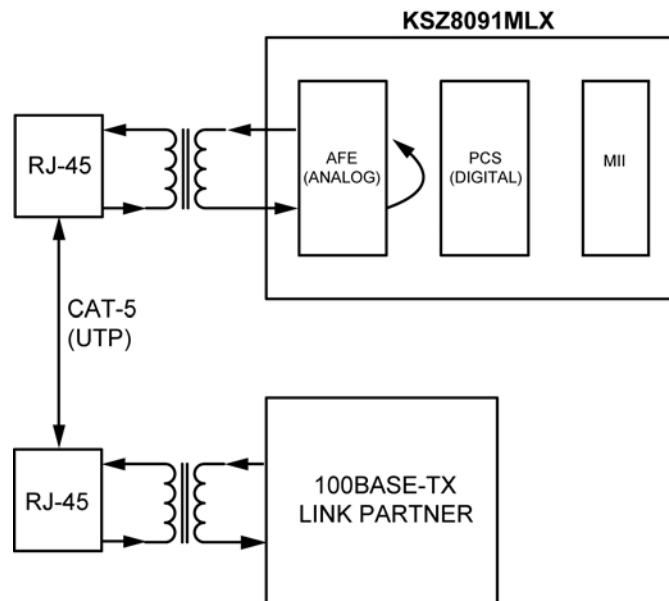

**Figure 7. Remote (Analog) Loopback**

The following programming steps and register settings are used for remote loopback mode.

1. Set Register 0h,
  - Bits [13] = 1 // Select 100Mbps speed
  - Bit [12] = 0 // Disable Auto-Negotiation
  - Bit [8] = 1 // Select full-duplex mode
 Or just auto-negotiate and link up with the link partner at 100Base-TX full-duplex mode.
2. Set Register 1Fh,
  - Bit [2] = 1 // Enable remote loopback mode

## LinkMD<sup>®</sup> Cable Diagnostic

The LinkMD function uses time-domain reflectometry (TDR) to analyze the cabling plant for common cabling problems. These include open circuits, short circuits, and impedance mismatches.

LinkMD works by sending a pulse of known amplitude and duration down the MDI or MDI-X pair, then analyzing the shape of the reflected signal to determine the type of fault. The time duration for the reflected signal to return provides the approximate distance to the cabling fault. The LinkMD function processes this TDR information and presents it as a numerical value that can be translated to a cable distance.

LinkMD is initiated by accessing Register 1Dh, the LinkMD Cable Diagnostic register, in conjunction with Register 1Fh, the PHY Control 2 Register. The latter register is used to disable Auto MDI/MDI-X and to select either MDI or MDI-X as the cable differential pair for testing.

### Usage

The following is a sample procedure for using LinkMD with Registers 1Dh and 1Fh:

3. Disable auto MDI/MDI-X by writing a '1' to Register 1Fh, bit [13].
4. Start cable diagnostic test by writing a '1' to Register 1Dh, bit [15]. This enable bit is self-clearing.
5. Wait (poll) for Register 1Dh, bit [15] to return a '0', and indicating cable diagnostic test is completed.
6. Read cable diagnostic test results in Register 1Dh, bits [14:13]. The results are as follows:
  - 00 = normal condition (valid test)
  - 01 = open condition detected in cable (valid test)
  - 10 = short condition detected in cable (valid test)
  - 11 = cable diagnostic test failed (invalid test)

The '11' case, invalid test, occurs when the device is unable to shut down the link partner. In this instance, the test is not run, since it would be impossible for the device to determine if the detected signal is a reflection of the signal generated or a signal from another source.

7. Get distance to fault by concatenating Register 1Dh, bits [8:0] and multiplying the result by a constant of 0.38. The distance to the cable fault can be determined by the following formula:

$$D \text{ (distance to cable fault)} = 0.38 \times \text{(Register 1Dh, bits [8:0])}$$

D (distance to cable fault) is expressed in meters.

Concatenated value of Registers 1Dh bits [8:0] should be converted to decimal before multiplying by 0.38.

The constant (0.38) may be calibrated for different cabling conditions, including cables with a velocity of propagation that varies significantly from the norm.

## NAND Tree Support

The KSZ8091MLX provides parametric NAND tree support for fault detection between chip I/Os and board. The NAND tree is a chain of nested NAND gates in which each KSZ8091MLX digital I/O (NAND tree input) pin is an input to one NAND gate along the chain. At the end of the chain, the CRS pin provides the output for the nested NAND gates.

The NAND tree test process includes:

- Enabling NAND tree mode
- Pulling all NAND tree input pins high
- Driving each NAND tree input pin low, sequentially, according to the NAND tree pin order
- Checking the NAND tree output to make sure there is a toggle high-to-low or low-to-high for each NAND tree input driven low

Table 5 lists the NAND tree pin order.

**Table 5. NAND Tree Test Pin Order for KSZ8091MLX**

Pin Number	Pin Name	NAND Tree Description
18	MDIO	Input
19	MDC	Input
20	RXD3	Input
21	RXD2	Input
22	RXD1	Input
23	RXD0	Input
27	RXDV	Input
28	RXC	Input
29	RXER	Input
32	INTRP	Input
33	TXC	Input
34	TXEN	Input
35	TXD0	Input
36	TXD1	Input
38	TXD2	Input
39	TXD3	Input
42	LED0	Input
43	LED1	Input
40	COL	Input
41	CRS	Output

### NAND Tree I/O Testing

Use the following procedure to check for faults on the KSZ8091MLX digital I/O pin connections to the board:

1. Enable NAND tree mode using either hardware (NAND\_Tree#, Pin 32) or software (Register 16h, Bit [5]).
2. Use board logic to drive all KSZ8091MLX NAND tree input pins high.
3. Use board logic to drive each NAND tree input pin, in KSZ8091MLX NAND tree pin order, as follows:
  - a. Toggle the first pin (MDIO) from high to low, and verify that the CRS pin switches from high to low to indicate that the first pin is connected properly.
  - b. Leave the first pin (MDIO) low.
  - c. Toggle the second pin (MDC) from high to low, and verify that the CRS pin switches from low to high to indicate that the second pin is connected properly.
  - d. Leave the first pin (MDIO) and the second pin (MDC) low.
  - e. Toggle the third pin (RXD3) from high to low, and verify that the CRS pin switches from high to low to indicate that the third pin is connected properly.
  - f. Continue with this sequence until all KSZ8091MLX NAND tree input pins have been toggled.

Each KSZ8091MLX NAND tree input pin must cause the CRS output pin to toggle high-to-low or low-to-high to indicate a good connection. If the CRS pin fails to toggle when the KSZ8091MLX input pin toggles from high to low, the input pin has a fault.

## Power Management

The KSZ8091MLX incorporates a number of power-management modes and features that provide methods to consume less energy. These are discussed in the following sections.

### Power-Saving Mode

Power-saving mode is used to reduce the transceiver power consumption when the cable is unplugged. It is enabled by writing a '1' to Register 1Fh, Bit [10], and is in effect when Auto-Negotiation mode is enabled and the cable is disconnected (no link).

In this mode, the KSZ8091MLX shuts down all transceiver blocks, except for the transmitter, energy detect, and PLL circuits.

By default, power-saving mode is disabled after power-up.

### Energy-Detect Power-Down Mode

Energy-detect power-down (EDPD) mode is used to further reduce transceiver power consumption when the cable is unplugged. It is enabled by writing a '0' to Register 18h, Bit [11], and is in effect when Auto-Negotiation mode is enabled and the cable is disconnected (no link).

EDPD mode works with the PLL off (set by writing a '1' to Register 10h, Bit [4] to automatically turn the PLL off in EDPD mode) to turn off all KSZ8091MLX transceiver blocks except the transmitter and energy-detect circuits.

Power can be reduced further by extending the time interval between transmissions of link pulses to check for the presence of a link partner. The periodic transmission of link pulses is needed to ensure the KSZ8091MLX and its link partner, when operating in the same low-power state and with Auto MDI/MDI-X disabled, can wake up when the cable is connected between them.

By default, EDPD mode is disabled after power-up.

### Power-Down Mode

Power-down mode is used to power down the KSZ8091MLX device when it is not in use after power-up. It is enabled by writing a '1' to Register 0h, Bit [11].

In this mode, the KSZ8091MLX disables all internal functions except the MII management interface. The KSZ8091MLX exits (disables) power-down mode after Register 0h, Bit [11] is set back to '0'.

### Slow-Oscillator Mode

Slow-oscillator mode is used to disconnect the input reference crystal/clock on XI (Pin 15) and select the on-chip slow oscillator when the KSZ8091MLX device is not in use after power-up. It is enabled by writing a '1' to Register 11h, Bit [5].

Slow-oscillator mode works in conjunction with power-down mode to put the KSZ8091MLX device in the lowest power state, with all internal functions disabled except the MII management interface. To properly exit this mode and return to normal PHY operation, use the following programming sequence:

1. Disable slow-oscillator mode by writing a '0' to Register 11h, Bit [5].
2. Disable power-down mode by writing a '0' to Register 0h, Bit [11].
3. Initiate software reset by writing a '1' to Register 0h, Bit [15].

## Efficient Ethernet (EEE)

The KSZ8091MLX implements Energy Efficient Ethernet (EEE) for the Media Independent Interface (MII) as described in IEEE Standard 802.3az. The Standard is defined around an EEE-compliant MAC on the host side and an EEE-compliant link partner on the line side that support special signaling associated with EEE. EEE saves power by keeping the AC signal on the copper Ethernet cable at approximately 0V peak-to-peak as often as possible during periods of no traffic activity, while maintaining the link-up status. This is referred to as low-power idle (LPI) mode or state.

During LPI mode, the copper link responds automatically when it receives traffic and resumes normal PHY operation immediately, without blockage of traffic or loss of packet. This involves exiting LPI mode and returning to normal 100Mbps operating mode. Wake-up time is <math><30\mu\text{s}</math> for 100Base-TX.

The LPI state is controlled independently for transmit and receive paths, allowing the LPI state to be active (enabled) for:

- Transmit cable path only
- Receive cable path only
- Both transmit and receive cable paths

The KSZ8091MLX has the EEE function disabled as the power-up default setting. To enable the EEE function for 100Mbps mode, use the following programming sequence:

1. Enable 100Mbps EEE mode advertisement by writing a '1' to MMD Address 7h, Register 3Ch, Bit [1].
2. Restart Auto-Negotiation by writing a '1' to standard Register 0h, Bit [9].

For standard (non-EEE) 10Base-T mode, normal link pulses (NLPs) with long periods of no AC signal transmission are used to maintain the link during the idle period when there is no traffic activity. To save more power, the KSZ8091MLX provides the option to enable 10Base-Te mode, which saves additional power by reducing the transmitted signal amplitude from 2.5V to 1.75V. To enable 10Base-Te mode, write a '1' to standard Register 13h, Bit [4] and write a '0' to MMD Address 1Ch, Register 4h, Bit [13].

During LPI mode, refresh transmissions are used to maintain the link; power savings occur in quiet periods. Approximately every 20 to 22 milliseconds, a refresh transmission of 200 to 220 microseconds is sent to the link partner. The refresh transmissions and quiet periods are shown in [Figure 8](#).

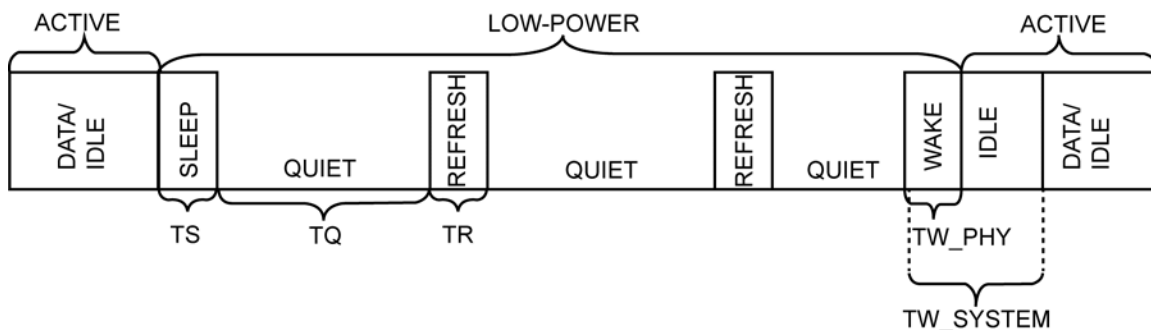

**Figure 8. LPI Mode (Refresh Transmissions and Quiet Periods)**

### Transmit Direction Control (MAC-to-PHY)

The KSZ8091MLX enters LPI mode for the transmit direction when its attached EEE-compliant MII MAC de-asserts TXEN, asserts TXER, and sets TXD[3:0] to 0001. The KSZ8091MLX remains in the LPI transmit state while the MAC maintains the states of these signals. When the MAC changes any of the TXEN, TXER, or TX data signals from their LPI state values, the KSZ8091MLX exits the LPI transmit state.

The TXC clock is not stopped, because it is sourced from the PHY and is used by the MAC for MII transmit.

[Figure 9](#) shows the LPI transition for MII (100Mbps) transmit.

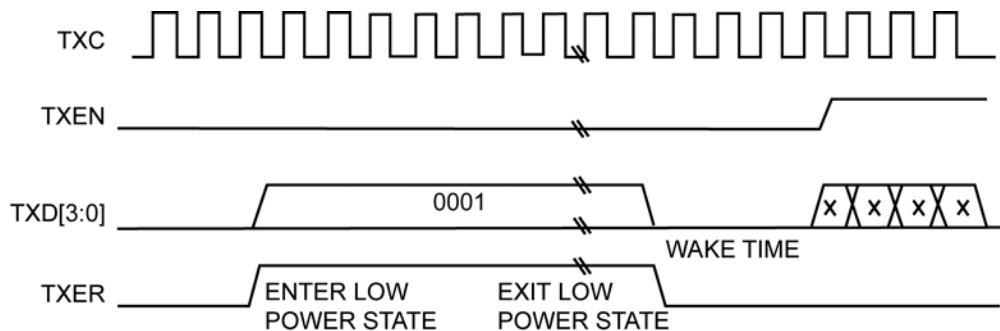

Figure 9. LPI Transition – MII (100Mbps) Transmit

**Receive Direction Control (PHY-to-MAC)**

The KSZ8091MLX enters LPI mode for the receive direction when it receives the /P/ code bit pattern (Sleep/Refresh) from its EEE-compliant link partner. It then de-asserts RXDV, asserts RXER, and drives RXD[3:0] to 0001. The KSZ8091MLX remains in the LPI receive state while it continues to receive the refresh from its link partner, so it will continue to maintain and drive the LPI output states for the MII receive signals to inform the attached EEE-compliant MII MAC that it is in the LPI receive state. When the KSZ8091MLX receives a non /P/ code bit pattern (non-refresh), it exits the LPI receive state and sets the RXDV, RXER, and RX data signals to set a normal frame or normal idle.

The KSZ8091MLX stops the RXC clock output to the MAC after nine or more RXC clock cycles have occurred in the LPI receive state, to save more power. By default, RXC clock stoppage is enabled. It is disabled by writing a '0' to MMD Address 3h, Register 0h, Bit [10].

Figure 10 shows the LPI transition for MII (100Mbps) receive.

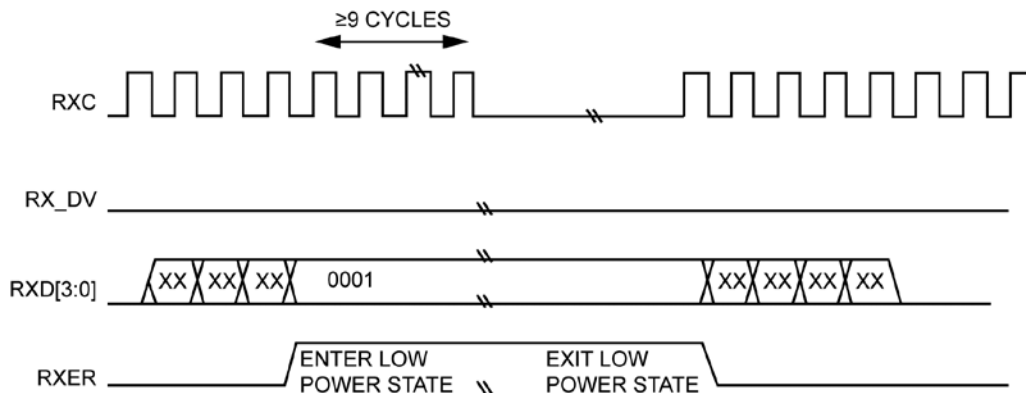

Figure 10. LPI Transition – MII (100Mbps) Receive

**Registers Associated with EEE**

The following registers are provided for EEE configuration and management:

- Standard Register 13h – AFE Control 4 (to enable 10Base-Te mode)
- MMD Address 1h, Register 0h – PMA/PMD Control 1 (to enable LPI)
- MMD Address 1h, Register 1h – PMA/PMD Status 1 (for LPI status)
- MMD Address 3h, Register 0h – EEE PCS Control 1 (to stop RXC clock)
- MMD Address 7h, Register 3Ch – EEE Advertisement
- MMD Address 7h, Register 3Dh – EEE Link Partner Advertisement
- MMD Address 1Ch, Register 4h – DSP 10Base-T/10Base-Te Control

## Wake-On-LAN

Wake-On-LAN (WOL) is normally a MAC-based function to wake up a host system (for example, an Ethernet end device, such as a PC) that is in standby power mode. Wake-up is triggered by receiving and detecting a special packet (commonly referred to as the “magic packet”) that is sent by the remote link partner. The KSZ8091MLX can perform the same WOL function if the MAC address of its associated MAC device is entered into the KSZ8091MLX PHY Registers for magic-packet detection. When the KSZ8091MLX detects the magic packet, it wakes up the host by driving its power management event (PME) output pin low.

By default, the WOL function is disabled. It is enabled by setting the enabling bit and configuring the associated registers for the selected PME wake-up detection method.

The KSZ8091MLX provides three methods to trigger a PME wake-up:

1. Magic-packet detection
2. Customized-packet detection
3. Link status change detection

### Magic-Packet Detection

The magic packet’s frame format starts with 6 bytes of 0xFFh and is followed by 16 repetitions of the MAC address of its associated MAC device (local MAC device).

When the magic packet is detected from its link partner, the KSZ8091MLX asserts its PME output pin low.

The following MMD Address 1Fh registers are provided for magic-packet detection:

- Magic-packet detection is enabled by writing a ‘1’ to MMD Address 1Fh, Register 0h, Bit [6]
- The MAC address (for the local MAC device) is written to and stored in MMD Address 1Fh, Registers 19h – 1Bh

The KSZ8091MLX does not generate the magic packet. The magic packet must be provided by the external system.

### Customized-Packet Detection

The customized packet has associated register/bit masks to select which byte, or bytes, of the first 64 bytes of the packet to use in the CRC calculation. After the KSZ8091MLX receives the packet from its link partner, the selected bytes for the received packet are used to calculate the CRC. The calculated CRC is compared to the expected CRC value that was previously written to and stored in the KSZ8091MLX PHY Registers. If there is a match, the KSZ8091MLX asserts its PME output pin low.

Four customized packets are provided to support four types of wake-up scenarios. A dedicated set of registers is used to configure and enable each customized packet.

The following MMD Registers are provided for customized-packet detection:

- Each of the four customized packets is enabled via MMD Address 1Fh, Register 0h,
  - Bit [2] // For customized packets, type 0
  - Bit [3] // For customized packets, type 1
  - Bit [4] // For customized packets, type 2
  - Bit [5] // For customized packets, type 3
- Masks to indicate which of the first 64-bytes to use in the CRC calculation are set in:
  - MMD Address 1Fh, Registers 1h – 4h // For customized packets, type 0
  - MMD Address 1Fh, Registers 7h – Ah // For customized packets, type 1
  - MMD Address 1Fh, Registers Dh – 10h // For customized packets, type 2
  - MMD Address 1Fh, Registers 13h – 16h // For customized packets, type 3



- 32-bit expected CRCs are written to and stored in:
  - MMD Address 1Fh, Registers 5h – 6h // For customized packets, type 0
  - MMD Address 1Fh, Registers Bh – Ch // For customized packets, type 1
  - MMD Address 1Fh, Registers 11h – 12h // For customized packets, type 2
  - MMD Address 1Fh, Registers 17h – 18h // For customized packets, type 3

### Link Status Change Detection

If link status change detection is enabled, the KSZ8091MLX asserts its PME output pin low whenever there is a link status change, using the following MMD Address 1Fh register bits and their enabled (1) or disabled (0) settings:

- MMD Address 1Fh, Register 0h, Bit [0] // For link-up detection
- MMD Address 1Fh, Register 0h, Bit [1] // For link-down detection

The PME output signal is available on either INTRP/PME\_N2 (Pin 32) or LED0/PME\_N1 (Pin 42), and is enabled using standard Register 16h, Bit [15]. MMD Address 1Fh, Register 0h, Bits [15:14] defines and selects the output functions for Pins 32 and 42.

The PME output is active low and requires a 1k $\Omega$  pull-up to the VDDIO supply. When asserted, the PME output is cleared by disabling the register bit that enabled the PME trigger source (magic packet, customized packet, link status change).

## Reference Circuit for Power and Ground Connections

The KSZ8091MLX is a single 3.3V supply device with a built-in regulator to supply the 1.2V core. The power and ground connections are shown in Figure 11 and Table 6 for 3.3V VDDIO.

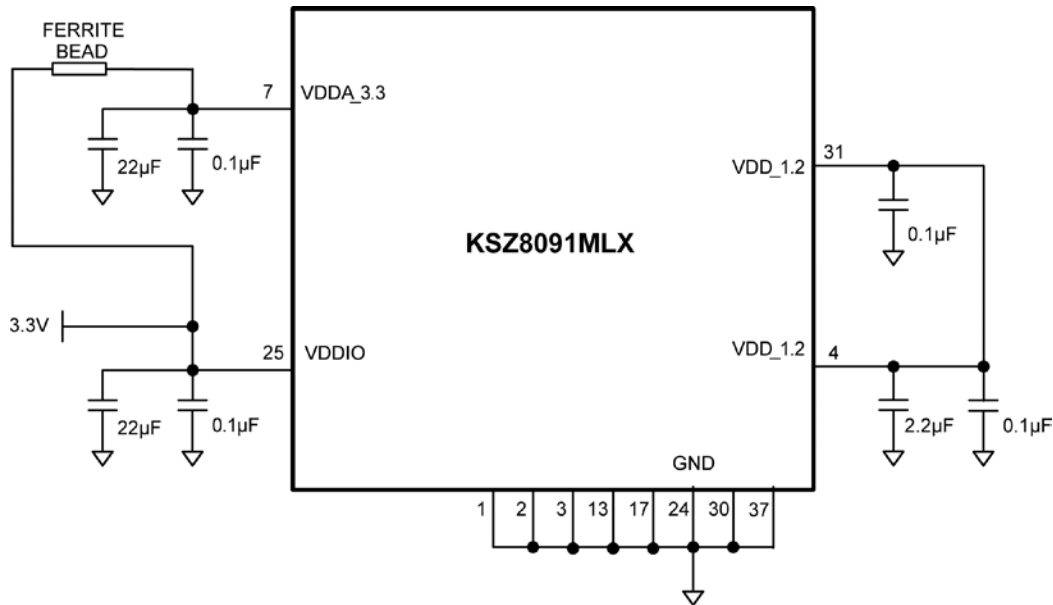

Figure 11. KSZ8091MLX Power and Ground Connections

Table 6. KSZ8091MLX Power Pin Description

Power Pin	Pin Number	Description
VDD_1.2	4	Connect with Pin 31 by power trace or plane. Decouple with 2.2µF and 0.1µF capacitors to ground.
VDDA_3.3	7	Connect to board's 3.3V supply through a ferrite bead. Decouple with 22µF and 0.1µF capacitors to ground.
VDDIO	25	Connect to board's 3.3V supply for 3.3V VDDIO. Decouple with 22µF and 0.1µF capacitors to ground.
VDD_1.2	31	Connect with Pin 4 by power trace or plane. Decouple with 0.1µF capacitor to ground.

## Typical Current/Power Consumption

Table 7, Table 8, Table 9 show typical values for current consumption by the transceiver (VDDA\_3.3) and digital I/O (VDDIO) power pins, as well as typical values for power consumption by the KSZ8091MLX device for the indicated nominal operating voltages. These current and power consumption values include the transmit driver current and on-chip regulator current for the 1.2V core.

### Transceiver (3.3V), Digital I/Os (3.3V)

Table 7. Typical Current/Power Consumption (VDDA\_3.3 = 3.3V, VDDIO = 3.3V)

Condition	3.3V Transceiver (VDDA_3.3)	3.3V Digital I/Os (VDDIO)	Total Chip Power
	mA	mA	mW
100Base-TX Link-up (no traffic)	34	12	152
100Base-TX Full-duplex @ 100% utilization	34	13	155
10Base-T Link-up (no traffic)	14	11	82.5
10Base-T Full-duplex @ 100% utilization	30	11	135
EEE 100Mbps Link-up mode (transmit and receive in LPI state with no traffic)	13	10	75.9
Power-saving mode (Reg. 1Fh, Bit [10] = 1)	13	10	75.9
EDPD mode (Reg. 18h, Bit [11] = 0)	10	10	66.0
EDPD mode (Reg. 18h, Bit [11] = 0) and PLL off (Reg. 10h, Bit [4] = 1)	3.77	1.54	17.5
Software power-down mode (Reg. 0h, Bit [11] = 1)	2.59	1.51	13.5
Software power-down mode (Reg. 0h, Bit [11] = 1) and slow-oscillator mode (Reg. 11h, Bit [5] = 1)	1.36	0.45	5.97

### Transceiver (3.3V), Digital I/Os (2.5V)

Table 8. Typical Current/Power Consumption (VDDA\_3.3 = 3.3V, VDDIO = 2.5V)

Condition	3.3V Transceiver (VDDA_3.3)	2.5V Digital I/Os (VDDIO)	Total Chip Power
	mA	mA	mW
100Base-TX Link-up (no traffic)	34	11	140
100Base-TX Full-duplex @ 100% utilization	34	12	142
10Base-T Link-up (no traffic)	15	10	74.5
10Base-T Full-duplex @ 100% utilization	27	10	114
EEE 100Mbps Link-up mode (transmit and receive in LPI state with no traffic)	13	10	67.9
Power-saving mode (Reg. 1Fh, Bit [10] = 1)	13	10	67.9
EDPD mode (Reg. 18h, Bit [11] = 0)	11	10	61.3
EDPD mode (Reg. 18h, Bit [11] = 0) and PLL off (Reg. 10h, Bit [4] = 1)	3.55	1.35	15.1
Software power-down mode (Reg. 0h, Bit [11] = 1)	2.29	1.34	10.9
Software power-down mode (Reg. 0h, Bit [11] = 1) and slow-oscillator mode (Reg. 11h, Bit [5] = 1)	1.15	0.29	4.52

**Transceiver (3.3V), Digital I/Os (1.8V)****Table 9. Typical Current/Power Consumption (VDDA\_3.3 = 3.3V, VDDIO = 1.8V)**

Condition	3.3V Transceiver (VDDA_3.3)	1.8V Digital I/Os (VDDIO)	Total Chip Power
	mA	mA	mW
100Base-TX Link-up (no traffic)	34	11	132
100Base-TX Full-duplex @ 100% utilization	34	12	134
10Base-T Link-up (no traffic)	15	9.0	65.7
10Base-T Full-duplex @ 100% utilization	27	9.0	105
EEE 100Mbps Link-up mode (transmit and receive in LPI state with no traffic)	13	9.0	59.1
Power-saving mode (Reg. 1Fh, Bit [10] = 1)	13	9.0	59.1
EDPD mode (Reg. 18h, Bit [11] = 0)	11	9.0	52.5
EDPD mode (Reg. 18h, Bit [11] = 0) and PLL off (Reg. 10h, Bit [4] = 1)	4.05	1.21	15.5
Software power-down mode (Reg. 0h, Bit [11] = 1)	2.79	1.21	11.4
Software power-down mode (Reg. 0h, Bit [11] = 1) and slow-oscillator mode (Reg. 11h, Bit [5] = 1)	1.65	0.19	5.79

## Register Map

The register space within the KSZ8091MLX consists of two distinct areas.

- Standard registers // Direct register access
- MDIO manageable device (MMD) registers // Indirect register access

The KSZ8091MLX supports the following standard registers:

**Table 10. Standard Registers Supported by KSZ8091MLX**

Register Number (Hex)	Description
<b>IEEE-Defined Registers</b>	
0h	Basic Control
1h	Basic Status
2h	PHY Identifier 1
3h	PHY Identifier 2
4h	Auto-Negotiation Advertisement
5h	Auto-Negotiation Link Partner Ability
6h	Auto-Negotiation Expansion
7h	Auto-Negotiation Next Page
8h	Auto-Negotiation Link Partner Next Page Ability
9h – Ch	Reserved
Dh	MMD Access – Control
Eh	MMD Access – Register/Data
Fh	Reserved
<b>Vendor-Specific Registers</b>	
10h	Digital Reserved Control
11h	AFE Control 1
12h	Reserved
13h	AFE Control 4
14h	Reserved
15h	RXER Counter
16h	Operation Mode Strap Override
17h	Operation Mode Strap Status
18h	Expanded Control
19h – 1Ah	Reserved
1Bh	Interrupt Control/Status
1Ch	Reserved
1Dh	LinkMD Cable Diagnostic
1Eh	PHY Control 1
1Fh	PHY Control 2

The KSZ8091MLX supports the following MMD device addresses and their associated register addresses, which make up the indirect MMD registers:

**Table 11. MMD Registers Supported by KSZ8091MLX**

Device Address (Hex)	Register Address (Hex)	Description
1h	0h	PMA/PMD Control 1
	1h	PMA/PMD Status 1
3h	0h	EEE PCS Control 1
7h	3Ch	EEE Advertisement
	3Dh	EEE Link Partner Advertisement
1Ch	4h	DSP 10Base-T/10Base-Te Control
1Fh	0h	Wake-On-LAN – Control
	1h	Wake-On-LAN – Customized Packet, Type 0, Mask 0
	2h	Wake-On-LAN – Customized Packet, Type 0, Mask 1
	3h	Wake-On-LAN – Customized Packet, Type 0, Mask 2
	4h	Wake-On-LAN – Customized Packet, Type 0, Mask 3
	5h	Wake-On-LAN – Customized Packet, Type 0, Expected CRC 0
	6h	Wake-On-LAN – Customized Packet, Type 0, Expected CRC 1
	7h	Wake-On-LAN – Customized Packet, Type 1, Mask 0
	8h	Wake-On-LAN – Customized Packet, Type 1, Mask 1
	9h	Wake-On-LAN – Customized Packet, Type 1, Mask 2
	Ah	Wake-On-LAN – Customized Packet, Type 1, Mask 3
	Bh	Wake-On-LAN – Customized Packet, Type 1, Expected CRC 0
	Ch	Wake-On-LAN – Customized Packet, Type 1, Expected CRC 1
	Dh	Wake-On-LAN – Customized Packet, Type 2, Mask 0
	Eh	Wake-On-LAN – Customized Packet, Type 2, Mask 1
	Fh	Wake-On-LAN – Customized Packet, Type 2, Mask 2
	10h	Wake-On-LAN – Customized Packet, Type 2, Mask 3
	11h	Wake-On-LAN – Customized Packet, Type 2, Expected CRC 0
	12h	Wake-On-LAN – Customized Packet, Type 2, Expected CRC 1
	13h	Wake-On-LAN – Customized Packet, Type 3, Mask 0
	14h	Wake-On-LAN – Customized Packet, Type 3, Mask 1
	15h	Wake-On-LAN – Customized Packet, Type 3, Mask 2
	16h	Wake-On-LAN – Customized Packet, Type 3, Mask 3
	17h	Wake-On-LAN – Customized Packet, Type 3, Expected CRC 0
	18h	Wake-On-LAN – Customized Packet, Type 3, Expected CRC 1
	19h	Wake-On-LAN – Magic Packet, MAC-DA-0
1Ah	Wake-On-LAN – Magic Packet, MAC-DA-1	
1Bh	Wake-On-LAN – Magic Packet, MAC-DA-2	

## Standard Registers

Standard registers provide direct read/write access to a 32-register address space, as defined in Clause 22 of the IEEE 802.3 Specification. Within this address space, the first 16 registers (Registers 0h to Fh) are defined according to the IEEE specification, while the remaining 16 registers (Registers 10h to 1Fh) are defined specific to the PHY vendor.

### IEEE-Defined Registers – Descriptions

Address	Name	Description	Mode <sup>(6)</sup>	Default
<b>Register 0h – Basic Control</b>				
0.15	Reset	1 = Software reset 0 = Normal operation This bit is self-cleared after a '1' is written to it.	RW/SC	0
0.14	Loopback	1 = Loopback mode 0 = Normal operation	RW	0
0.13	Speed Select	1 = 100Mbps 0 = 10Mbps This bit is ignored if Auto-Negotiation is enabled (Register 0.12 = 1).	RW	Set by the SPEED strapping pin. See the <a href="#">Strapping Options</a> section for details.
0.12	Auto-Negotiation Enable	1 = Enable Auto-Negotiation process 0 = Disable Auto-Negotiation process If enabled, the Auto-Negotiation result overrides the settings in Registers 0.13 and 0.8.	RW	Set by the NWAYEN strapping pin. See the <a href="#">Strapping Options</a> section for details.
0.11	Power-Down	1 = Power-down mode 0 = Normal operation If software reset (Register 0.15) is used to exit power-down mode (Register 0.11 = 1), two software reset writes (Register 0.15 = 1) are required. The first write clears power-down mode; the second write resets the chip and re-latches the pin strapping pin values.	RW	0
0.10	Isolate	1 = Electrical isolation of PHY from MII 0 = Normal operation	RW	Set by the ISO strapping pin. See the <a href="#">Strapping Options</a> section for details.
0.9	Restart Auto-Negotiation	1 = Restart Auto-Negotiation process 0 = Normal operation. This bit is self-cleared after a '1' is written to it.	RW/SC	0
0.8	Duplex Mode	1 = Full-duplex 0 = Half-duplex	RW	The inverse of the DUPLEX strapping pin value. See the <a href="#">Strapping Options</a> section for details.
0.7	Collision Test	1 = Enable COL test 0 = Disable COL test	RW	0
0.6:0	Reserved	Reserved	RO	000_0000

**Note:**

6. RW = Read/Write.  
RO = Read only.  
SC = Self-cleared.  
LH = Latch high.  
LL = Latch low.

**IEEE-Defined Registers – Descriptions (Continued)**

Address	Name	Description	Mode <sup>(6)</sup>	Default
<b>Register 1h – Basic Status</b>				
1.15	100Base-T4	1 = T4 capable 0 = Not T4 capable	RO	0
1.14	100Base-TX Full-Duplex	1 = Capable of 100Mbps full-duplex 0 = Not capable of 100Mbps full-duplex	RO	1
1.13	100Base-TX Half-Duplex	1 = Capable of 100Mbps half-duplex 0 = Not capable of 100Mbps half-duplex	RO	1
1.12	10Base-T Full-Duplex	1 = Capable of 10Mbps full-duplex 0 = Not capable of 10Mbps full-duplex	RO	1
1.11	10Base-T Half-Duplex	1 = Capable of 10Mbps half-duplex 0 = Not capable of 10Mbps half-duplex	RO	1
1.10:7	Reserved	Reserved	RO	000_0
1.6	No Preamble	1 = Preamble suppression 0 = Normal preamble	RO	1
1.5	Auto-Negotiation Complete	1 = Auto-negotiation process completed 0 = Auto-negotiation process not completed	RO	0
1.4	Remote Fault	1 = Remote fault 0 = No remote fault	RO/LH	0
1.3	Auto-Negotiation Ability	1 = Can perform auto-negotiation 0 = Cannot perform auto-negotiation	RO	1
1.2	Link Status	1 = Link is up 0 = Link is down	RO/LL	0
1.1	Jabber Detect	1 = Jabber detected 0 = Jabber not detected (default is low)	RO/LH	0
1.0	Extended Capability	1 = Supports extended capability registers	RO	1
<b>Register 2h – PHY Identifier 1</b>				
2.15:0	PHY ID Number	Assigned to the 3rd through 18th bits of the Organizationally Unique Identifier (OUI). KENDIN Communication's OUI is 0010A1 (hex).	RO	0022h
<b>Register 3h – PHY Identifier 2</b>				
3.15:10	PHY ID Number	Assigned to the 19th through 24th bits of the Organizationally Unique Identifier (OUI). KENDIN Communication's OUI is 0010A1 (hex).	RO	0001_01
3.9:4	Model Number	Six-bit manufacturer's model number	RO	01_0110
3.3:0	Revision Number	Four-bit manufacturer's revision number	RO	Indicates silicon revision



**IEEE-Defined Registers – Descriptions (Continued)**

Address	Name	Description	Mode <sup>(6)</sup>	Default
<b>Register 4h – Auto-Negotiation Advertisement</b>				
4.15	Next Page	1 = Next page capable 0 = No next page capability	RW	0
4.14	Reserved	Reserved	RO	0
4.13	Remote Fault	1 = Remote fault supported 0 = No remote fault	RW	0
4.12	Reserved	Reserved	RO	0
4.11:10	Pause	[00] = No pause [10] = Asymmetric pause [01] = Symmetric pause [11] = Asymmetric and symmetric pause	RW	00
4.9	100Base-T4	1 = T4 capable 0 = No T4 capability	RO	0
4.8	100Base-TX Full-Duplex	1 = 100Mbps full-duplex capable 0 = No 100Mbps full-duplex capability	RW	Set by the SPEED strapping pin. See the <a href="#">Strapping Options</a> section for details.
4.7	100Base-TX Half-Duplex	1 = 100Mbps half-duplex capable 0 = No 100Mbps half-duplex capability	RW	Set by the SPEED strapping pin. See the <a href="#">Strapping Options</a> section for details.
4.6	10Base-T Full-Duplex	1 = 10Mbps full-duplex capable 0 = No 10Mbps full-duplex capability	RW	1
4.5	10Base-T Half-Duplex	1 = 10Mbps half-duplex capable 0 = No 10Mbps half-duplex capability	RW	1
4.4:0	Selector Field	[00001] = IEEE 802.3	RW	0_0001
<b>Register 5h – Auto-Negotiation Link Partner Ability</b>				
5.15	Next Page	1 = Next page capable 0 = No next page capability	RO	0
5.14	Acknowledge	1 = Link code word received from partner 0 = Link code word not yet received	RO	0
5.13	Remote Fault	1 = Remote fault detected 0 = No remote fault	RO	0
5.12	Reserved	Reserved	RO	0
5.11:10	Pause	[00] = No pause [10] = Asymmetric pause [01] = Symmetric pause [11] = Asymmetric and symmetric pause	RO	00
5.9	100Base-T4	1 = T4 capable 0 = No T4 capability	RO	0
5.8	100Base-TX Full-Duplex	1 = 100Mbps full-duplex capable 0 = No 100Mbps full-duplex capability	RO	0
5.7	100Base-TX Half-Duplex	1 = 100Mbps half-duplex capable 0 = No 100Mbps half-duplex capability	RO	0

**IEEE-Defined Registers – Descriptions (Continued)**

Address	Name	Description	Mode <sup>(6)</sup>	Default
5.6	10Base-T Full-Duplex	1 = 10Mbps full-duplex capable 0 = No 10Mbps full-duplex capability	RO	0
5.5	10Base-T Half-Duplex	1 = 10Mbps half-duplex capable 0 = No 10Mbps half-duplex capability	RO	0
5.4:0	Selector Field	[00001] = IEEE 802.3	RO	0_0001
<b>Register 6h – Auto-Negotiation Expansion</b>				
6.15:5	Reserved	Reserved	RO	0000_0000_000
6.4	Parallel Detection Fault	1 = Fault detected by parallel detection 0 = No fault detected by parallel detection	RO/LH	0
6.3	Link Partner Next Page Able	1 = Link partner has next page capability 0 = Link partner does not have next page capability	RO	0
6.2	Next Page Able	1 = Local device has next page capability 0 = Local device does not have next page capability	RO	1
6.1	Page Received	1 = New page received 0 = New page not received yet	RO/LH	0
6.0	Link Partner Auto-Negotiation Able	1 = Link partner has auto-negotiation capability 0 = Link partner does not have auto-negotiation capability	RO	0
<b>Register 7h – Auto-Negotiation Next Page</b>				
7.15	Next Page	1 = Additional next pages will follow 0 = Last page	RW	0
7.14	Reserved	Reserved	RO	0
7.13	Message Page	1 = Message page 0 = Unformatted page	RW	1
7.12	Acknowledge2	1 = Will comply with message 0 = Cannot comply with message	RW	0
7.11	Toggle	1 = Previous value of the transmitted link code word equal to logic 0 0 = Previous value of the transmitted link code word equal to logic 1	RO	0
7.10:0	Message Field	11-bit wide field to encode 2048 messages	RW	000_0000_0001
<b>Register 8h – Auto-Negotiation Link Partner Next Page Ability</b>				
8.15	Next Page	1 = Additional next pages will follow 0 = Last page	RO	0
8.14	Acknowledge	1 = Successful receipt of link word 0 = No successful receipt of link word	RO	0
8.13	Message Page	1 = Message page 0 = Unformatted page	RO	0
8.12	Acknowledge2	1 = Can act on the information 0 = Cannot act on the information	RO	0

**IEEE-Defined Registers – Descriptions (Continued)**

Address	Name	Description	Mode <sup>(6)</sup>	Default
8.11	Toggle	1 = Previous value of transmitted link code word equal to logic 0 0 = Previous value of transmitted link code word equal to logic 1	RO	0
8.10:0	Message Field	11-bit wide field to encode 2048 messages	RO	000_0000_0000
<b>Register Dh – MMD Access – Control</b>				
D.15:14	MMD – Operation Mode	For the selected MMD Device Address (Bits [4:0] of this register), these two bits select one of the following register or data operations and the usage for MMD Access – Register/Data (Reg. Eh). 00 = Register 01 = Data, no post increment 10 = Data, post increment on reads and writes 11 = Data, post increment on writes only	RW	00
D.13:5	Reserved	Reserved	RW	00_0000_000
D.4:0	MMD – Device Address	These five bits set the MMD device address.	RW	0_0000
<b>Register Eh – MMD Access – Register/Data</b>				
E.15:0	MMD – Register/Data	For the selected MMD Device Address (Reg. Dh, Bits [4:0]), When Reg. Dh, Bits [15:14] = 00, this register contains the read/write register address for the MMD Device Address. Otherwise, this register contains the read/write data value for the MMD Device Address and its selected register address. See also Reg. Dh, Bits [15:14], for descriptions of post increment reads and writes of this register for data operation.	RW	0000_0000_0000_0000

**Vendor-Specific Registers – Descriptions**

Address	Name	Description	Mode <sup>(7)</sup>	Default
<b>Register 10h – Digital Reserved Control</b>				
10.15:5	Reserved	Reserved	RW	0000_0000_000
10.4	PLL Off	1 = Turn PLL off automatically in EDPD mode 0 = Keep PLL on in EDPD mode.  See also Register 18h, Bit [11] for EDPD mode	RW	0
10.3:0	Reserved	Reserved	RW	0000
<b>Register 11h – AFE Control 1</b>				
11.15:6	Reserved	Reserved	RW	0000_0000_00
11.5	Slow-Oscillator Mode Enable	Slow-oscillator mode is used to disconnect the input reference crystal/clock on the XI pin and select the on-chip slow oscillator when the KSZ8091MLX device is not in use after power-up. 1 = Enable 0 = Disable This bit automatically sets software power-down to the analog side when enabled.	RW	0
11.4:0	Reserved	Reserved	RW	0_0000
<b>Register 13h – AFE Control 4</b>				
13.15:5	Reserved	Reserved	RW	0000_0000_000
13.4	10Base-Te Mode	1 = EEE 10Base-Te (1.75V TX amplitude) and also set MMD Address 1Ch, Register 4h, Bit [13] to '0'. 0 = Standard 10Base-T (2.5V TX amplitude) and also set MMD Address 1Ch, Register 4h, Bit [13] to '1'.	RW	0
13.3:0	Reserved	Reserved	RW	0000
<b>Register 15h – RXER Counter</b>				
15.15:0	RXER Counter	Receive error counter for symbol error frames	RO/SC	0000h
<b>Register 16h – Operation Mode Strap Override</b>				
16.15	PME Enable	PME for Wake-on-LAN 1 = Enable 0 = Disable This bit works in conjunction with MMD Address 1Fh, Reg. 0h, Bits [15:14] to define the output for Pins 32 and 42.	RW	Set by the PME_EN strapping pin. See the <a href="#">Strapping Options</a> section for details.
16.14:11	Reserved	Reserved	RW	000_0
16.10	Reserved	Reserved	RO	0
16.9	B-CAST_OFF Override	1 = Override strap-in for B-CAST_OFF If bit is '1', PHY Address 0 is non-broadcast.	RW	0
16.8	Reserved	Reserved	RW	0

**Note:**

7. RW = Read/Write.  
RO = Read only.  
SC = Self-cleared.

**Vendor-Specific Registers – Descriptions (Continued)**

Address	Name	Description	Mode <sup>(7)</sup>	Default
16.7	MII B-to-B Override	1 = Override strap-in for MII back-to-back mode (also set Bit 0 of this register to '1')	RW	0
16.6	Reserved	Reserved	RW	0
16.5	NAND Tree Override	1 = Override strap-in for NAND tree mode	RW	0
16.4:1	Reserved	Reserved	RW	0_000
16.0	MII Override	1 = Override strap-in for MII mode	RW	1
<b>Register 17h – Operation Mode Strap Status</b>				
17.15:13	PHYAD[2:0] Strap-In Status	[000] = Strap to PHY Address 0 [001] = Strap to PHY Address 1 [010] = Strap to PHY Address 2 [011] = Strap to PHY Address 3 [100] = Strap to PHY Address 4 [101] = Strap to PHY Address 5 [110] = Strap to PHY Address 6 [111] = Strap to PHY Address 7	RO	
17.12:10	Reserved	Reserved	RO	
17.9	B-CAST_OFF Strap-In Status	1 = Strap to B-CAST_OFF If bit is '1', PHY Address 0 is non-broadcast.	RO	
17.8	Reserved	Reserved	RO	
17.7	MII B-to-B Strap-In Status	1 = Strap to MII back-to-back mode.	RO	
17.6	Reserved	Reserved	RO	
17.5	NAND Tree Strap-In Status	1 = Strap to NAND tree mode	RO	
17.4:1	Reserved	Reserved	RO	
17.0	MII Strap-In Status	1 = Strap to MII mode	RO	
<b>Register 18h – Expanded Control</b>				
18.15:12	Reserved	Reserved	RW	0000
18.11	EDPD Disabled	Energy-detect power-down mode 1 = Disable 0 = Enable See also Register 10h, Bit [4] for PLL off.	RW	1
18.10	100Base-TX Latency	1 = MII output is random latency 0 = MII output is fixed latency For both settings, all bytes of received preamble are passed to the MII output.	RW	0
18.9:7	Reserved	Reserved	RW	00_0
18.6	10Base-T Preamble Restore	1 = Restore received preamble to MII output 0 = Remove all seven bytes of preamble before sending frame (starting with SFD) to MII output	RW	0
18.5:0	Reserved	Reserved	RW	00_0001

**Vendor-Specific Registers – Descriptions (Continued)**

Address	Name	Description	Mode <sup>(7)</sup>	Default
<b>Register 1Bh – Interrupt Control/Status</b>				
1B.15	Jabber Interrupt Enable	1 = Enable jabber interrupt 0 = Disable jabber interrupt	RW	0
1B.14	Receive Error Interrupt Enable	1 = Enable receive error interrupt 0 = Disable receive error interrupt	RW	0
1B.13	Page Received Interrupt Enable	1 = Enable page received interrupt 0 = Disable page received interrupt	RW	0
1B.12	Parallel Detect Fault Interrupt Enable	1 = Enable parallel detect fault interrupt 0 = Disable parallel detect fault interrupt	RW	0
1B.11	Link Partner Acknowledge Interrupt Enable	1 = Enable link partner acknowledge interrupt 0 = Disable link partner acknowledge interrupt	RW	0
1B.10	Link-Down Interrupt Enable	1 = Enable link-down interrupt 0 = Disable link-down interrupt	RW	0
1B.9	Remote Fault Interrupt Enable	1 = Enable remote fault interrupt 0 = Disable remote fault interrupt	RW	0
1B.8	Link-Up Interrupt Enable	1 = Enable link-up interrupt 0 = Disable link-up interrupt	RW	0
1B.7	Jabber Interrupt	1 = Jabber occurred 0 = Jabber did not occur	RO/SC	0
1B.6	Receive Error Interrupt	1 = Receive error occurred 0 = Receive error did not occur	RO/SC	0
1B.5	Page Receive Interrupt	1 = Page receive occurred 0 = Page receive did not occur	RO/SC	0
1B.4	Parallel Detect Fault Interrupt	1 = Parallel detect fault occurred 0 = Parallel detect fault did not occur	RO/SC	0
1B.3	Link Partner Acknowledge Interrupt	1 = Link partner acknowledge occurred 0 = Link partner acknowledge did not occur	RO/SC	0
1B.2	Link-Down Interrupt	1 = Link-down occurred 0 = Link-down did not occur	RO/SC	0
1B.1	Remote Fault Interrupt	1 = Remote fault occurred 0 = Remote fault did not occur	RO/SC	0
1B.0	Link-Up Interrupt	1 = Link-up occurred 0 = Link-up did not occur	RO/SC	0

**Vendor-Specific Registers – Descriptions (Continued)**

Address	Name	Description	Mode <sup>(7)</sup>	Default
<b>Register 1Dh – LinkMD Cable Diagnostic</b>				
1D.15	Cable Diagnostic Test Enable	1 = Enable cable diagnostic test. After test has completed, this bit is self-cleared. 0 = Indicates cable diagnostic test (if enabled) has completed and the status information is valid for read.	RW/SC	0
1D.14:13	Cable Diagnostic Test Result	[00] = Normal condition [01] = Open condition has been detected in cable [10] = Short condition has been detected in cable [11] = Cable diagnostic test has failed	RO	00
1D.12	Short Cable Short Indicator	1 = A short cable (<10 meter) short condition has been detected by LinkMD	RO	0
1D.11:9	Reserved	Reserved	RW	000
1D.8:0	Cable Fault Counter	Distance to fault	RO	0_0000_0000
<b>Register 1Eh – PHY Control 1</b>				
1E.15:10	Reserved	Reserved	RO	0000_00
1E.9	Enable Pause (Flow Control)	1 = Flow control capable 0 = No flow control capability	RO	0
1E.8	Link Status	1 = Link is up 0 = Link is down	RO	0
1E.7	Polarity Status	1 = Polarity is reversed 0 = Polarity is not reversed	RO	
1E.6	Reserved	Reserved	RO	0
1E.5	MDI/MDI-X State	1 = MDI-X 0 = MDI	RO	
1E.4	Energy Detect	1 = Signal present on receive differential pair 0 = No signal detected on receive differential pair	RO	0
1E.3	PHY Isolate	1 = PHY in isolate mode 0 = PHY in normal operation	RW	0
1E.2:0	Operation Mode Indication	[000] = Still in auto-negotiation [001] = 10Base-T half-duplex [010] = 100Base-TX half-duplex [011] = Reserved [100] = Reserved [101] = 10Base-T full-duplex [110] = 100Base-TX full-duplex [111] = Reserved	RO	000

**Vendor-Specific Registers – Descriptions (Continued)**

Address	Name	Description	Mode <sup>(7)</sup>	Default
<b>Register 1Fh – PHY Control 2</b>				
1F.15	HP_MDIX	1 = HP Auto MDI/MDI-X mode 0 = Micrel Auto MDI/MDI-X mode	RW	1
1F.14	MDI/MDI-X Select	When Auto MDI/MDI-X is disabled, 1 = MDI-X mode: Transmit on RXP,RXM (pins 10, 9) and Receive on TXP,TXM (pins 12, 11) 0 = MDI mode: Transmit on TXP,TXM (pins 12, 11) and Receive on RXP,RXM (pins 10, 9)	RW	0
1F.13	Pair Swap Disable	1 = Disable Auto MDI/MDI-X 0 = Enable Auto MDI/MDI-X	RW	0
1F.12	Reserved	Reserved	RW	0
1F.11	Force Link	1 = Force link pass 0 = Normal link operation This bit bypasses the control logic and allows the transmitter to send a pattern even if there is no link.	RW	0
1F.10	Power Saving	1 = Enable power saving 0 = Disable power saving	RW	0
1F.9	Interrupt Level	1 = Interrupt pin active high 0 = Interrupt pin active low	RW	0
1F.8	Enable Jabber	1 = Enable jabber counter 0 = Disable jabber counter	RW	1
1F.7:6	Reserved	Reserved	RW	00
1F.5:4	LED Mode	[00] = LED1: Speed LED0: Link/Activity [01] = LED1: Activity LED0: Link [10], [11] = Reserved	RW	00
1F.3	Disable Transmitter	1 = Disable transmitter 0 = Enable transmitter	RW	0
1F.2	Remote Loopback	1 = Remote (analog) loopback is enabled 0 = Normal mode	RW	0
1F.1	Enable SQE Test	1 = Enable SQE test 0 = Disable SQE test	RW	0
1F.0	Disable Data Scrambling	1 = Disable scrambler 0 = Enable scrambler	RW	0



## MMD Registers

MMD registers provide indirect read/write access to up to 32 MMD Device Addresses with each device supporting up to 65,536 16-bit registers, as defined in Clause 22 of the IEEE 802.3 Specification. The KSZ8091MLX, however, uses only a small fraction of the available registers. See the [Register Map](#) section for a list of supported MMD device addresses and their associated register addresses.

The following two standard registers serve as the portal registers to access the indirect MMD registers.

- Standard Register Dh – MMD Access – Control
- Standard Register Eh – MMD Access – Register/Data

**Table 12. Portal Registers (Access to Indirect MMD Registers)**

Address	Name	Description	Mode	Default
<b>Register Dh – MMD Access – Control</b>				
D.15:14	MMD – Operation Mode	For the selected MMD Device Address (Bits [4:0] of this register), these two bits select one of the following register or data operations and the usage for MMD Access – Register/Data (Reg. Eh). 00 = Register 01 = Data, no post increment 10 = Data, post increment on reads and writes 11 = Data, post increment on writes only	RW	00
D.13:5	Reserved	Reserved	RW	00_0000_000
D.4:0	MMD – Device Address	These five bits set the MMD device address.	RW	0_0000
<b>Register Eh – MMD Access – Register/Data</b>				
E.15:0	MMD – Register/Data	For the selected MMD Device Address (Reg. Dh, Bits [4:0]), When Reg. Dh, Bits [15:14] = 00, this register contains the read/write register address for the MMD Device Address. Otherwise, this register contains the read/write data value for the MMD Device Address and its selected register address. See also Register Dh, Bits [15:14] descriptions for post increment reads and writes of this register for data operation.	RW	0000_0000_0000_0000

Examples:

### **MMD Register Write**

Write MMD – Device Address 1Fh, Register 0h = 0001h to enable link-up detection to trigger PME for WOL.

1. Write Register Dh with 001Fh // Set up register address for MMD – Device Address 1Fh.
2. Write Register Eh with 0000h // Select Register 0h of MMD – Device Address 1Fh.
3. Write Register Dh with 401Fh // Select register data for MMD – Device Address 1Fh, Register 0h.
4. Write Register Eh with 0001h // Write value 0001h to MMD – Device Address 1Fh, Register 0h.

### **MMD Register Read**

Read MMD – Device Address 1Fh, Register 19h – 1Bh for the magic packet's MAC address

1. Write Register Dh with 001Fh // Set up register address for MMD – Device Address 1Fh.
2. Write Register Eh with 0019h // Select Register 19h of MMD – Device Address 1Fh.
3. Write Register Dh with 801Fh // Select register data for MMD – Device Address 1Fh, Register 19h  
// with post increments
4. Read Register Eh // Read data in MMD – Device Address 1Fh, Register 19h.
5. Read Register Eh // Read data in MMD – Device Address 1Fh, Register 1Ah.
6. Read Register Eh // Read data in MMD – Device Address 1Fh, Register 1Bh.

**MMD Registers – Descriptions**

Address	Name	Description	Mode <sup>(8)</sup>	Default
<b>MMD Address 1h, Register 0h – PMA/PMD Control 1</b>				
1.0.15:13	Reserved	Reserved	RW	000
1.0.12	LPI enable	Lower Power Idle enable	RW	0
1.0.11:0	Reserved	Reserved	RW	0000_0000_0000
<b>MMD Address 1h, Register 1h – PMA/PMD Status 1</b>				
1.1.15:9	Reserved	Reserved	RO	0000_000
1.1.8	LPI State Entered	1 = PMA/PMD has entered LPI state 0 = PMA/PMD has not entered LPI state	RO/LH	0
1.1.7:4	Reserved	Reserved	RO	0000
1.1.3	LPI State Indication	1 = PMA/PMD is currently in LPI state 0 = PMA/PMD is currently not in LPI state	RO	0
1.1.2:0	Reserved	Reserved	RO	000
<b>MMD Address 3h, Register 0h – EEE PCS Control 1</b>				
3.0.15:12	Reserved	Reserved	RO	0000
3.0.11	Reserved	Reserved	RW	1
3.0.10	100Base-TX RXC Clock Stoppable	During receive lower-power idle mode, 1 = RXC clock is stoppable for 100Base-TX 0 = RXC clock is not stoppable for 100Base-TX	RW	1
3.0.9:4	Reserved	Reserved	RW	00_0001
3.0.3:2	Reserved	Reserved	RO	00
3.0.1:0	Reserved	Reserved	RW	00
<b>MMD Address 7h, Register 3Ch – EEE Advertisement</b>				
7.3C.15:3	Reserved	Reserved	RO	0000_0000_0000_0
7.3C.2	1000Base-T EEE Capable	0 = 1000Mbps EEE is not supported	RO	0
7.3C.1	100Base-TX EEE Capable	1 = 100Mbps EEE capable 0 = No 100Mbps EEE capability This bit is set to '0' as the default after power-up or reset. Set this bit to '1' to enable 100Mbps EEE mode.	RW	0
7.3C.0	Reserved	Reserved	RO	0

**Note:**

8. RW = Read/Write.  
RO = Read only.  
LH = Latch high.

**MMD Registers – Descriptions (Continued)**

Address	Name	Description	Mode <sup>(8)</sup>	Default
<b>MMD Address 7h, Register 3Dh – EEE Link Partner Advertisement</b>				
7.3D.15:3	Reserved	Reserved	RO	0000_0000_0000_0
7.3D.2	1000Base-T EEE Capable	1 = 1000Mbps EEE capable 0 = No 1000Mbps EEE capability	RO	0
7.3D.1	100Base-TX EEE Capable	1 = 100Mbps EEE capable 0 = No 100Mbps EEE capability	RO	0
7.3D.0	Reserved	Reserved	RO	0
<b>MMD Address 1Ch, Register 4h – DSP 10Base-T/10Base-Te Control</b>				
1C.4.15	Reserved	Reserved	RW	0
1C.4.14	Reserved	Reserved	RO	0
1C.4.13	DSP 10Base-T/10Base-Te Mode Select	1 = Standard 10Base-T (2.5V TX amplitude) and also set Standard Register 13h, Bit [4] to '0'. 0 = EEE 10Base-Te (1.75 TX amplitude) and also set Standard Register 13h, Bit [4] to '1'.	RW	1
1C.4.12	Reserved	Reserved	RW	0
1C.4.11:0	Reserved	Reserved	RO	0000_0000_0000
<b>MMD Address 1Fh, Register 0h – Wake-On-LAN – Control</b>				
1F.0.15:14	PME Output Select	These two bits work in conjunction with Reg. 16h, Bit [15] for PME Enable to define the output for Pins 32 and 42. INTRP/PME_N2 (Pin 32): 00 = INTRP output 01 = PME_N2 output 10 = INTRP and PME_N2 output 11 = Reserved  LED0/PME_N1 (Pin 42): 00 = PME_N1 output 01 = LED0 output 10 = LED0 output 11 = PME_N1 output	RW	00
1F.0.13:7	Reserved	Reserved	RO	00_0000_0
1F.0.6	Magic Packet Detect Enable	1 = Enable magic-packet detection 0 = Disable magic-packet detection	RW	0
1F.0.5	Custom – Packet Type 3 Detect Enable	1 = Enable custom-packet, Type 3 detection 0 = Disable custom-packet, Type 3 detection	RW	0
1F.0.4	Custom – Packet Type 2 Detect Enable	1 = Enable custom-packet, Type 2 detection 0 = Disable custom-packet, Type 2 detection	RW	0

**MMD Registers – Descriptions (Continued)**

Address	Name	Description	Mode <sup>(8)</sup>	Default
1F.0.3	Custom – Packet Type 1 Detect Enable	1 = Enable custom-packet, Type 1 detection 0 = Disable custom-packet, Type 1 detection	RW	0
1F.0.2	Custom-Packet Type 0 Detect Enable	1 = Enable custom-packet, Type 0 detection 0 = Disable custom-packet, Type 0 detection	RW	0
1F.0.1	Link-Down Detect Enable	1 = Enable link-down detection 0 = Disable link-down detection	RW	0
1F.0.0	Link-Up Detect Enable	1 = Enable link-up detection 0 = Disable link-up detection	RW	0
<b>MMD Address 1Fh, Register 1h – Wake-On-LAN – Customized Packet, Type 0, Mask 0</b> <b>MMD Address 1Fh, Register 7h – Wake-On-LAN – Customized Packet, Type 1, Mask 0</b> <b>MMD Address 1Fh, Register Dh – Wake-On-LAN – Customized Packet, Type 2, Mask 0</b> <b>MMD Address 1Fh, Register 13h – Wake-On-LAN – Customized Packet, Type 3, Mask 0</b>				
1F.1.15:0 1F.7.15:0 1F.D.15:0 1F.13.15:0	Custom Packet Type X Mask 0	<p>This register selects the bytes in the first 16 bytes of the packet (bytes 1 thru 16) that will be used for CRC calculation.</p> <p>For each bit in this register,</p> <p>1 = Byte is selected for CRC calculation 0 = Byte is not selected for CRC calculation</p> <p>The register-bit to packet-byte mapping is as follows:</p> <p>Bit [15] : byte-16 ... : ... Bit [1] : byte-2 Bit [0] : byte-1</p>	RW	0000_0000_0000_0000
<b>MMD Address 1Fh, Register 2h – Wake-On-LAN – Customized Packet, Type 0, Mask 1</b> <b>MMD Address 1Fh, Register 8h – Wake-On-LAN – Customized Packet, Type 1, Mask 1</b> <b>MMD Address 1Fh, Register Eh – Wake-On-LAN – Customized Packet, Type 2, Mask 1</b> <b>MMD Address 1Fh, Register 14h – Wake-On-LAN – Customized Packet, Type 3, Mask 1</b>				
1F.2.15:0 1F.8.15:0 1F.E.15:0 1F.14.15:0	Custom Packet Type X Mask 1	<p>This register selects the bytes in the second 16 bytes of the packet (bytes 17 thru 32) that will be used for CRC calculation.</p> <p>For each bit in this register,</p> <p>1 = Byte is selected for CRC calculation 0 = Byte is not selected for CRC calculation</p> <p>The register-bit to packet-byte mapping is as follows:</p> <p>Bit [15] : byte-32 ... : ... Bit [1] : byte-18 Bit [0] : byte-17</p>	RW	0000_0000_0000_0000

**MMD Registers – Descriptions (Continued)**

Address	Name	Description	Mode <sup>(8)</sup>	Default
<b>MMD Address 1Fh, Register 3h – Wake-On-LAN – Customized Packet, Type 0, Mask 2</b> <b>MMD Address 1Fh, Register 9h – Wake-On-LAN – Customized Packet, Type 1, Mask 2</b> <b>MMD Address 1Fh, Register Fh – Wake-On-LAN – Customized Packet, Type 2, Mask 2</b> <b>MMD Address 1Fh, Register 15h – Wake-On-LAN – Customized Packet, Type 3, Mask 2</b>				
1F.3.15:0 1F.9.15:0 1F.F.15:0 1F.15.15:0	Custom Packet Type X Mask 2	<p>This register selects the bytes in the third 16 bytes of the packet (Bytes 33 thru 48) that will be used for CRC calculation.</p> <p>For each bit in this register,</p> <p>1 = Byte is selected for CRC calculation</p> <p>0 = Byte is not selected for CRC calculation</p> <p>The register-bit to packet-byte mapping is as follows:</p> <p>Bit [15] :        byte-48</p> <p>...                :        ...</p> <p>Bit [1]    :        byte-34</p> <p>Bit [0]    :        byte-33</p>	RW	0000_0000_0000_0000
<b>MMD Address 1Fh, Register 4h – Wake-On-LAN – Customized Packet, Type 0, Mask 3</b> <b>MMD Address 1Fh, Register Ah – Wake-On-LAN – Customized Packet, Type 1, Mask 3</b> <b>MMD Address 1Fh, Register 10h – Wake-On-LAN – Customized Packet, Type 2, Mask 3</b> <b>MMD Address 1Fh, Register 16h – Wake-On-LAN – Customized Packet, Type 3, Mask 3</b>				
1F.4.15:0 1F.A.15:0 1F.10.15:0 1F.16.15:0	Custom Packet Type X Mask 3	<p>This register selects the bytes in the fourth 16 bytes of the packet (bytes 49 thru 64) that will be used for CRC calculation.</p> <p>For each bit in this register,</p> <p>1 = Byte is selected for CRC calculation</p> <p>0 = Byte is not selected for CRC calculation</p> <p>The register-bit to packet-byte mapping is as follows:</p> <p>Bit [15] :        byte-64</p> <p>...                :        ...</p> <p>Bit [1]    :        byte-50</p> <p>Bit [0]    :        byte-49</p>	RW	0000_0000_0000_0000
<b>MMD Address 1Fh, Register 5h – Wake-On-LAN – Customized Packet, Type 0, Expected CRC 0</b> <b>MMD Address 1Fh, Register Bh – Wake-On-LAN – Customized Packet, Type 1, Expected CRC 0</b> <b>MMD Address 1Fh, Register 11h – Wake-On-LAN – Customized Packet, Type 2, Expected CRC 0</b> <b>MMD Address 1Fh, Register 17h – Wake-On-LAN – Customized Packet, Type 3, Expected CRC 0</b>				
1F.5.15:0 1F.B.15:0 1F.11.15:0 1F.17.15:0	Custom Packet Type X CRC 0	<p>This register stores the lower two bytes for the expected CRC.</p> <p>Bit [15:8]= Byte 2 (CRC [15:8])</p> <p>Bit [7:0] = Byte 1 (CRC [7:0])</p> <p>The upper two bytes for the expected CRC are stored in the following register.</p>	RW	0000_0000_0000_0000

**MMD Registers – Descriptions (Continued)**

Address	Name	Description	Mode <sup>(8)</sup>	Default
<b>MMD Address 1Fh, Register 6h – Wake-On-LAN – Customized Packet, Type 0, Expected CRC 1</b>				
<b>MMD Address 1Fh, Register Ch – Wake-On-LAN – Customized Packet, Type 1, Expected CRC 1</b>				
<b>MMD Address 1Fh, Register 12h – Wake-On-LAN – Customized Packet, Type 2, Expected CRC 1</b>				
<b>MMD Address 1Fh, Register 18h – Wake-On-LAN – Customized Packet, Type 3, Expected CRC 1</b>				
1F.6.15:0 1F.C.15:0 1F.12.15:0 1F.18.15:0	Custom Packet Type X CRC 1	This register stores the upper two bytes for the expected CRC. Bit [15:8]= Byte 4 (CRC [31:24]) Bit [7:0] = Byte 3 (CRC [23:16]) The lower two bytes for the expected CRC are stored in the previous register.	RW	0000_0000_0000_0000
<b>MMD Address 1Fh, Register 19h – Wake-On-LAN – Magic Packet, MAC-DA-0</b>				
1F.19.15:0	Magic Packet MAC-DA-0	This register stores the lower two bytes of the destination MAC address for the magic packet. Bit [15:8]= Byte 2 (MAC Address [15:8]) Bit [7:0] = Byte 1 (MAC Address [7:0]) The upper four bytes of the destination MAC address are stored in the following two registers.	RW	0000_0000_0000_0000
<b>MMD Address 1Fh, Register 1Ah – Wake-On-LAN – Magic Packet, MAC-DA-1</b>				
1F.1A.15:0	Magic Packet MAC-DA-1	This register stores the middle two bytes of the destination MAC address for the magic packet. Bit [15:8]= Byte 4 (MAC Address [31:24]) Bit [7:0] = Byte 3 (MAC Address [23:16]) The lower two bytes and upper two bytes of the destination MAC address are stored in the previous and following registers, respectively.	RW	0000_0000_0000_0000
<b>MMD Address 1Fh, Register 1Bh – Wake-On-LAN – Magic Packet, MAC-DA-2</b>				
1F.1B.15:0	Magic Packet MAC-DA-2	This register stores the upper two bytes of the destination MAC address for the magic packet. Bit [15:8]= Byte 6 (MAC Address [47:40]) Bit [7:0] = Byte 5 (MAC Address [39:32]) The lower four bytes of the destination MAC address are stored in the previous two registers.	RW	0000_0000_0000_0000

### Absolute Maximum Ratings<sup>(9)</sup>

Supply Voltage ( $V_{IN}$ )	
( $V_{DD_1.2}$ )	-0.5V to +1.8V
( $V_{DDIO}, V_{DDA_3.3}$ )	-0.5V to +5.0V
Input Voltage (all inputs)	-0.5V to +5.0V
Output Voltage (all outputs)	-0.5V to +5.0V
Lead Temperature (soldering, 10s)	260°C
Storage Temperature ( $T_S$ )	-55°C to +150°C

### Operating Ratings<sup>(10)</sup>

Supply Voltage	
( $V_{DDIO_3.3}, V_{DDA_3.3}$ )	+3.135V to +3.465V
( $V_{DDIO_2.5}$ )	+2.375V to +2.625V
( $V_{DDIO_1.8}$ )	+1.710V to +1.890V
Ambient Temperature	
( $T_A$ , Commercial)	0°C to +70°C
( $T_A$ , Industrial)	-40°C to +85°C
Maximum Junction Temperature ( $T_J$ maximum)	125°C
Thermal Resistance ( $\theta_{JA}$ )	76°C/W
Thermal Resistance ( $\theta_{JC}$ )	15°C/W

### Electrical Characteristics<sup>(11)</sup>

Symbol	Parameter	Condition	Min.	Typ.	Max.	Units
<b>Supply Current (<math>V_{DDIO}, V_{DDA_3.3} = 3.3V</math>)<sup>(12)</sup></b>						
$I_{DD1_3.3V}$	10Base-T	Full-duplex traffic @ 100% utilization		41		mA
$I_{DD2_3.3V}$	100Base-TX	Full-duplex traffic @ 100% utilization		47		mA
$I_{DD3_3.3V}$	EEE (100Mbps) Mode	TX and RX paths in LPI state with no traffic		23		mA
$I_{DD4_3.3V}$	EDPD Mode	Ethernet cable disconnected (Reg. 18h.11 = 0)		20		mA
$I_{DD5_3.3V}$	Power-Down Mode	Software power-down (Reg. 0h.11 = 1)		4		mA
<b>CMOS Level Inputs</b>						
$V_{IH}$	Input High Voltage	$V_{DDIO} = 3.3V$	2.0			V
		$V_{DDIO} = 2.5V$	1.8			
		$V_{DDIO} = 1.8V$	1.3			
$V_{IL}$	Input Low Voltage	$V_{DDIO} = 3.3V$			0.8	V
		$V_{DDIO} = 2.5V$			0.7	
		$V_{DDIO} = 1.8V$			0.5	
$ I_{IN} $	Input Current	$V_{IN} = GND \sim V_{DDIO}$			10	$\mu A$
<b>CMOS Level Outputs</b>						
$V_{OH}$	Output High Voltage	$V_{DDIO} = 3.3V$	2.4			V
		$V_{DDIO} = 2.5V$	2.0			
		$V_{DDIO} = 1.8V$	1.5			
$V_{OL}$	Output Low Voltage	$V_{DDIO} = 3.3V$			0.4	V
		$V_{DDIO} = 2.5V$			0.4	
		$V_{DDIO} = 1.8V$			0.3	
$ I_{OZ} $	Output Tri-State Leakage				10	$\mu A$
<b>LED Output</b>						
$I_{LED}$	Output Drive Current	Each LED pin (LED0, LED1)		8		mA

**Notes:**

- 9. Exceeding the absolute maximum ratings may damage the device. Stresses greater than the absolute maximum rating can cause permanent damage to the device. Operation of the device at these or any other conditions above those specified in the operating sections of this specification is not implied. Maximum conditions for extended periods may affect reliability.
- 10. The device is not guaranteed to function outside its operating ratings.
- 11.  $T_A = 25^\circ C$ . Specification for packaged product only.
- 12. Current consumption is for the single 3.3V supply KSZ8091MLX device only, and includes the transmit driver current and the 1.2V supply voltage ( $V_{DD_1.2}$ ) that are supplied by the KSZ8091MLX.



**Electrical Characteristics<sup>(11)</sup> (Continued)**

Symbol	Parameter	Condition	Min.	Typ.	Max.	Units
<b>All Pull-Up/Pull-Down Pins (including Strapping Pins)</b>						
pu	Internal Pull-Up Resistance	V <sub>DDIO</sub> = 3.3V	30	45	73	kΩ
		V <sub>DDIO</sub> = 2.5V	39	61	102	
		V <sub>DDIO</sub> = 1.8V	48	99	178	
pd	Internal Pull-Down Resistance	V <sub>DDIO</sub> = 3.3V	26	43	79	kΩ
		V <sub>DDIO</sub> = 2.5V	34	59	113	
		V <sub>DDIO</sub> = 1.8V	53	99	200	
<b>100Base-TX Transmit (measured differentially after 1:1 transformer)</b>						
V <sub>O</sub>	Peak Differential Output Voltage	100Ω termination across differential output	0.95		1.05	V
V <sub>IMB</sub>	Output Voltage Imbalance	100Ω termination across differential output			2	%
t <sub>r</sub> , t <sub>f</sub>	Rise/Fall Time		3		5	ns
	Rise/Fall Time Imbalance		0		0.5	ns
	Duty Cycle Distortion				±0.25	ns
	Overshoot				5	%
	Output Jitter	Peak-to-peak		0.7		ns
<b>10Base-T Transmit (measured differentially after 1:1 transformer)</b>						
V <sub>P</sub>	Peak Differential Output Voltage	100Ω termination across differential output	2.2		2.8	V
	Jitter Added	Peak-to-peak			3.5	ns
t <sub>r</sub> , t <sub>f</sub>	Rise/Fall Time			25		ns
<b>10Base-T Receive</b>						
V <sub>SQ</sub>	Squelch Threshold	5MHz square wave		400		mV
<b>Transmitter – Drive Setting</b>						
V <sub>SET</sub>	Reference Voltage of I <sub>SET</sub>	R(I <sub>SET</sub> ) = 6.49kΩ		0.65		V
<b>100Mbps Mode – Industrial Applications Parameters</b>						
	Clock Phase Delay – XI Input to MII TXC Output	XI (25MHz clock input) to MII TXC (25MHz clock output) delay, referenced to rising edges of both clocks.	15	20	25	ns
t <sub>llr</sub>	Link Loss Reaction (Indication) Time	Link loss detected at receive differential inputs to PHY signal indication time for each of the following: 1. For LED mode 00, Speed LED output changes from low (100Mbps) to high (10Mbps, default state for link-down). 2. For LED mode 01, Link LED output changes from low (link-up) to high (link-down). 3. INTRP pin asserts for link-down status change.		4.4		μs

## Timing Diagrams

### MII SQE Timing (10Base-T)

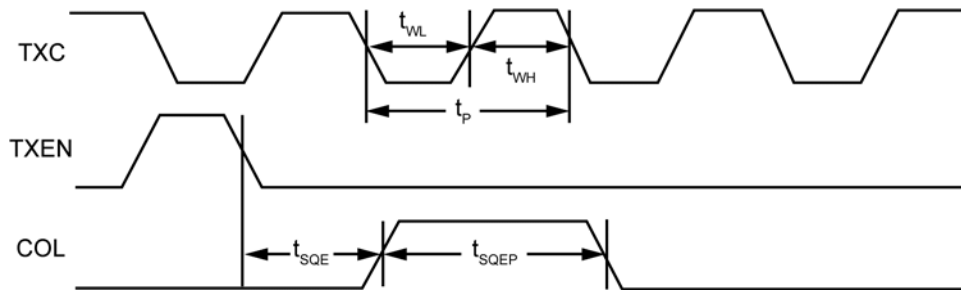
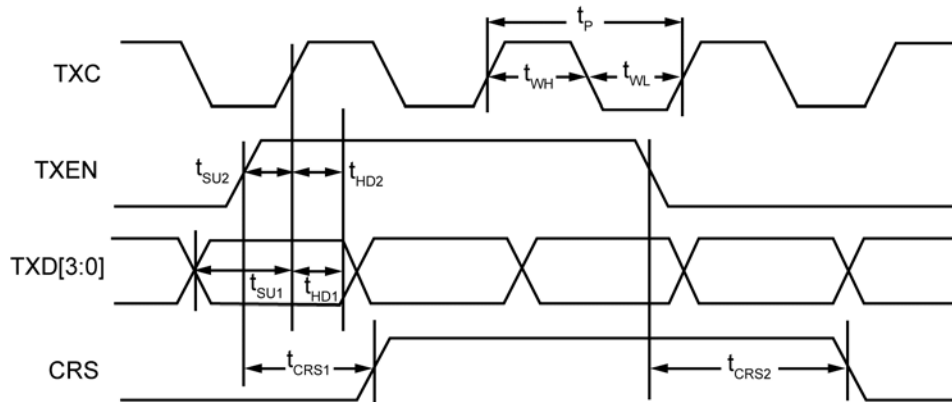

Figure 12. MII SQE Timing (10Base-T)

Table 13. MII SQE Timing (10Base-T) Parameters

Timing Parameter	Description	Min.	Typ.	Max.	Unit
$t_P$	TXC period		400		ns
$t_{WL}$	TXC pulse width low		200		ns
$t_{WH}$	TXC pulse width high		200		ns
$t_{SQE}$	COL (SQE) delay after TXEN de-asserted		2.2		$\mu$ s
$t_{SQEP}$	COL (SQE) pulse duration		1.0		$\mu$ s

**MII Transmit Timing (10Base-T)**

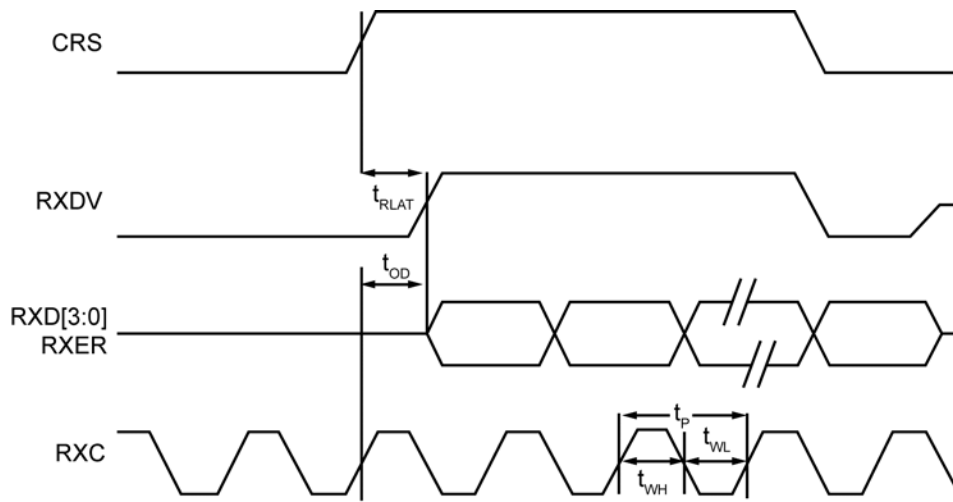

**Figure 13. MII Transmit Timing (10Base-T)**

**Table 14. MII Transmit Timing (10Base-T) Parameters**

Timing Parameter	Description	Min.	Typ.	Max.	Unit
$t_p$	TXC period		400		ns
$t_{WL}$	TXC pulse width low		200		ns
$t_{WH}$	TXC pulse width high		200		ns
$t_{SU1}$	TXD[3:0] setup to rising edge of TXC	120			ns
$t_{SU2}$	TXEN setup to rising edge of TXC	120			ns
$t_{HD1}$	TXD[3:0] hold from rising edge of TXC	0			ns
$t_{HD2}$	TXEN hold from rising edge of TXC	0			ns
$t_{CRS1}$	TXEN high to CRS asserted latency		600		ns
$t_{CRS2}$	TXEN low to CRS de-asserted latency		1.0		$\mu$ s

**MII Receive Timing (10Base-T)**

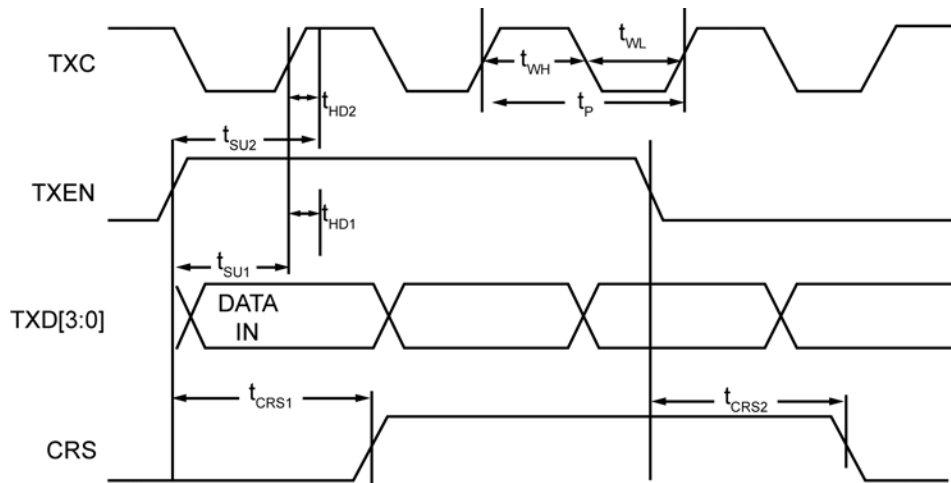

**Figure 14. MII Receive Timing (10Base-T)**

**Table 15. MII Receive Timing (10Base-T) Parameters**

Timing Parameter	Description	Min.	Typ.	Max.	Unit
$t_p$	RXC period		400		ns
$t_{WL}$	RXC pulse width low		200		ns
$t_{WH}$	RXC pulse width high		200		ns
$t_{OD}$	(RXDV, RXD[3:0], RXER) output delay from rising edge of RXC		205		ns
$t_{RLAT}$	CRS to (RXDV, RXD[3:0]) latency		7.2		$\mu$ s

**MII Transmit Timing (100Base-TX)**

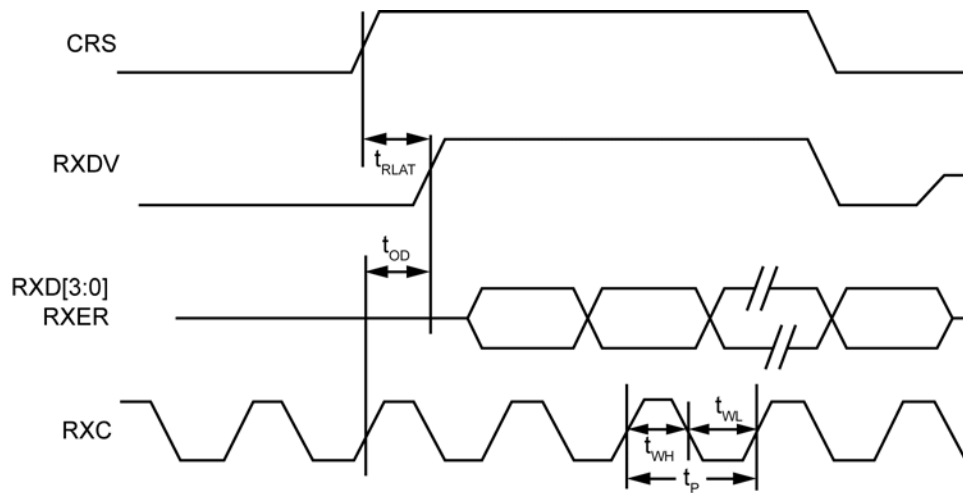

**Figure 15. MII Transmit Timing (100Base-TX)**

**Table 16. MII Transmit Timing (100Base-TX) Parameters**

Timing Parameter	Description	Min.	Typ.	Max.	Unit
$t_P$	TXC period		40		ns
$t_{WL}$	TXC pulse width low		20		ns
$t_{WH}$	TXC pulse width high		20		ns
$t_{SU1}$	TXD[3:0] setup to rising edge of TXC	10			ns
$t_{SU2}$	TXEN setup to rising edge of TXC	10			ns
$t_{HD1}$	TXD[3:0] hold from rising edge of TXC	0			ns
$t_{HD2}$	TXEN hold from rising edge of TXC	0			ns
$t_{CRS1}$	TXEN high to CRS asserted latency		72		ns
$t_{CRS2}$	TXEN low to CRS de-asserted latency		72		ns

**MII Receive Timing (100Base-TX)**



**Figure 16. MII Receive Timing (100Base-TX)**

**Table 17. MII Receive Timing (100Base-TX) Parameters**

Timing Parameter	Description	Min.	Typ.	Max.	Unit
$t_P$	RXC period		40		ns
$t_{WL}$	RXC pulse width low		20		ns
$t_{WH}$	RXC pulse width high		20		ns
$t_{OD}$	(RXDV, RXD[3:0], RXER) output delay from rising edge of RXC	16	21	25	ns
$t_{RLAT}$	CRS to (RXDV, RXD[3:0]) latency		170		ns

Auto-Negotiation Timing

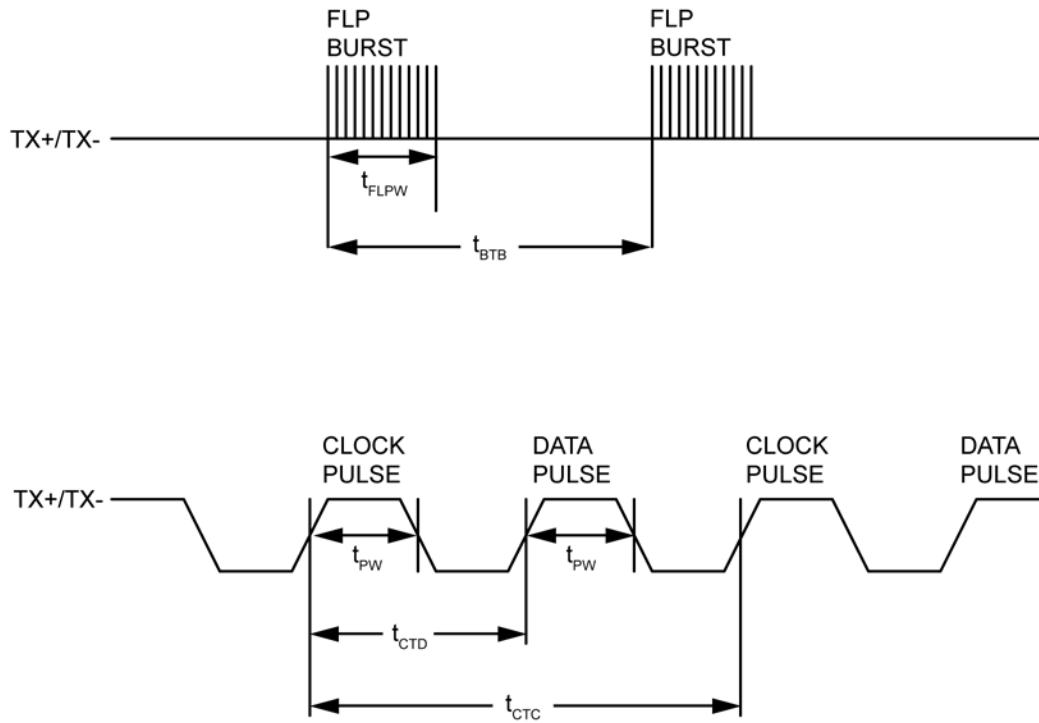
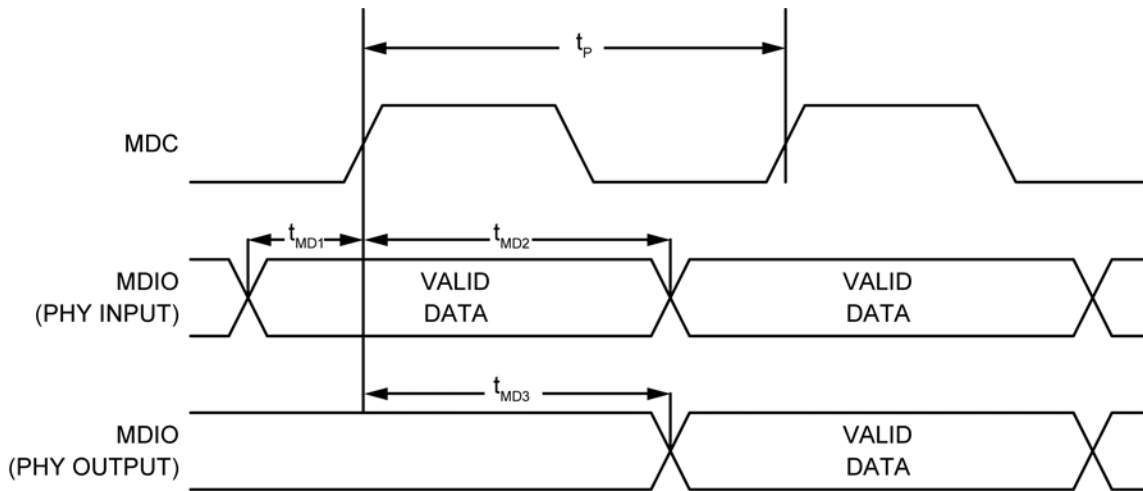

Figure 17. Auto-Negotiation Fast Link Pulse (FLP) Timing

Table 18. Auto-Negotiation Fast Link Pulse (FLP) Timing Parameters

Timing Parameter	Description	Min.	Typ.	Max.	Unit
$t_{BTB}$	FLP burst to FLP burst	8	16	24	ms
$t_{FLPW}$	FLP burst width		2		ms
$t_{PW}$	Clock/data pulse width		100		ns
$t_{CTD}$	Clock pulse to data pulse	55.5	64	69.5	$\mu$ s
$t_{CTC}$	Clock pulse to clock pulse	111	128	139	$\mu$ s
	Number of clock/data pulses per FLP burst	17		33	

**MDC/MDIO Timing**



**Figure 18. MDC/MDIO Timing**

**Table 19. MDC/MDIO Timing Parameters**

Timing Parameter	Description	Min.	Typ.	Max.	Unit
$f_c$	MDC Clock Frequency		2.5	10MHz	
$t_P$	MDC period		400		ns
$t_{MD1}$	MDIO (PHY input) setup to rising edge of MDC	10			ns
$t_{MD2}$	MDIO (PHY input) hold from rising edge of MDC	4			ns
$t_{MD3}$	MDIO (PHY output) delay from rising edge of MDC	5	222		ns



## Power-Up/Reset Timing

The KSZ8091MLX reset timing requirement is summarized in [Figure 19](#) and [Table 20](#).

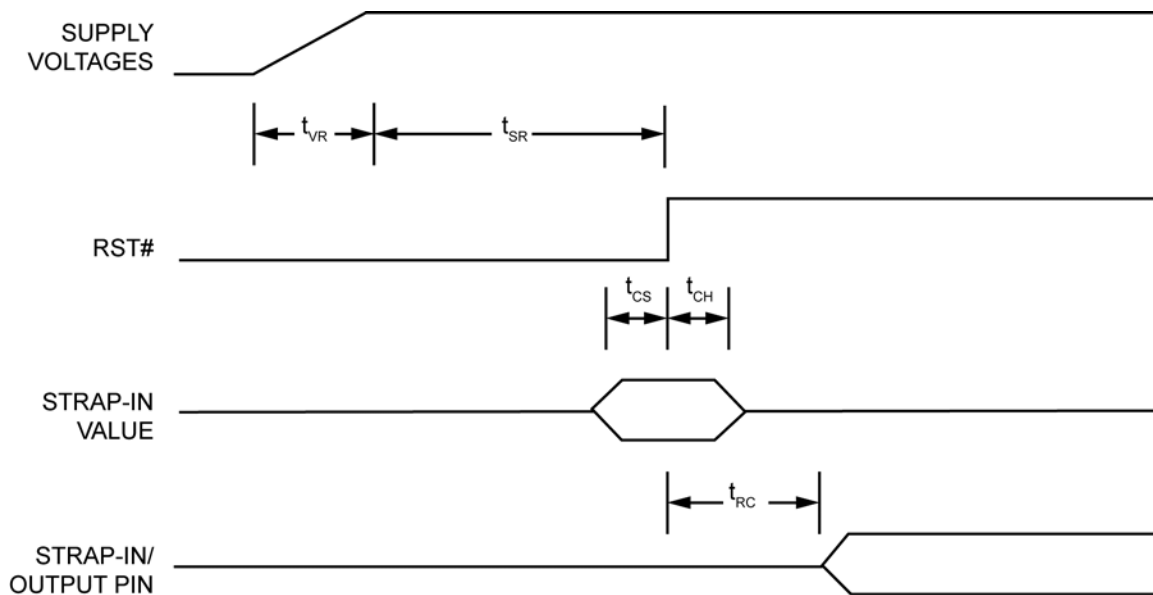

Figure 19. Power-Up/Reset Timing

Table 20. Power-Up/Reset Timing Parameters

Timing Parameter	Description	Min.	Typ.	Max.	Unit
$t_{VR}$	Supply voltage ( $V_{DDIO}$ , $V_{DDA_{3.3}}$ ) rise time	300			$\mu\text{s}$
$t_{SR}$	Stable supply voltage ( $V_{DDIO}$ , $V_{DDA_{3.3}}$ ) to reset high	10			ms
$t_{CS}$	Configuration setup time	5			ns
$t_{CH}$	Configuration hold time	5			ns
$t_{RC}$	Reset to strap-in pin output	6			ns

The supply voltage ( $V_{DDIO}$  and  $V_{DDA_{3.3}}$ ) power-up waveform should be monotonic. The 300 $\mu\text{s}$  minimum rise time is from 10% to 90%.

For warm reset, the reset (RST#) pin should be asserted low for a minimum of 500 $\mu\text{s}$ . The strap-in pin values are read and updated at the de-assertion of reset.

After the de-assertion of reset, wait a minimum of 100 $\mu\text{s}$  before starting programming on the MIIM (MDC/MDIO) interface.

## Reset Circuit

Figure 20 shows a reset circuit recommended for powering up the KSZ8091MLX if reset is triggered by the power supply.

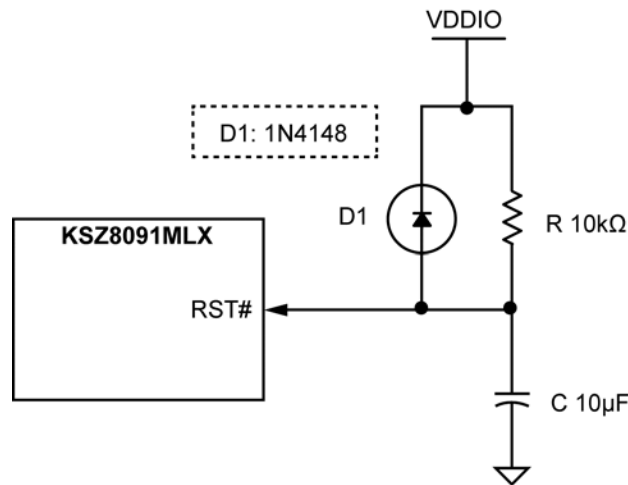

Figure 20. Recommended Reset Circuit

Figure 21 Shows a reset circuit recommended for applications where reset is driven by another device (for example, the CPU or an FPGA). The reset out RST\_OUT\_n from CPU/FPGA provides the warm reset after power up reset. D2 is used if using different VDDIO between the switch and CPU/FPGA, otherwise, the different VDDIO will fight each other. If different VDDIO have to use in a special case, a low VF (<0.3V) diode is required (For example, VISHAY’s BAT54, MSS1P2L and so on), or a level shifter device can be used too. If Ethernet device and CPU/FPGA use same VDDIO voltage, D2 can be removed to connect both devices directly. Usually, Ethernet device and CPU/FPGA should use same VDDIO voltage.

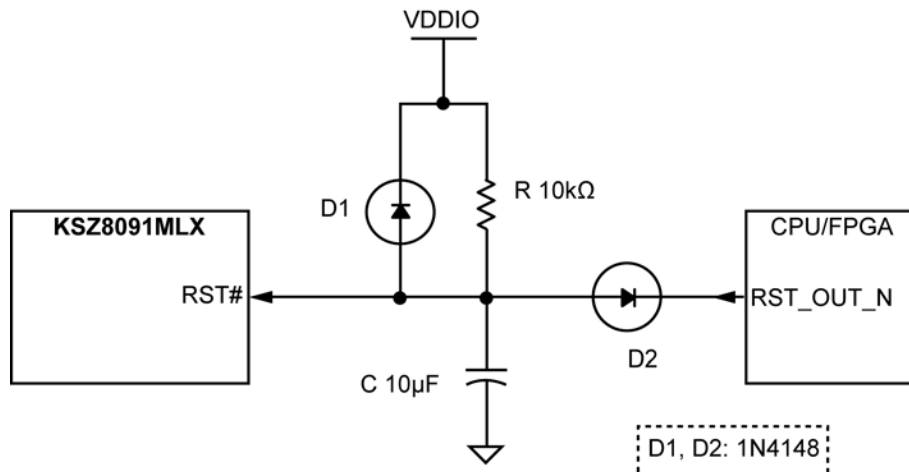

Figure 21. Recommended Reset Circuit for Interfacing with CPU/FPGA Reset Output

## Reference Circuits – LED Strap-In Pins

The pull-up, float, and pull-down reference circuits for the LED1/SPEED and LED0/PME\_N1/NWAYEN strapping pins are shown in Figure 22 for 3.3V and 2.5V VDDIO.

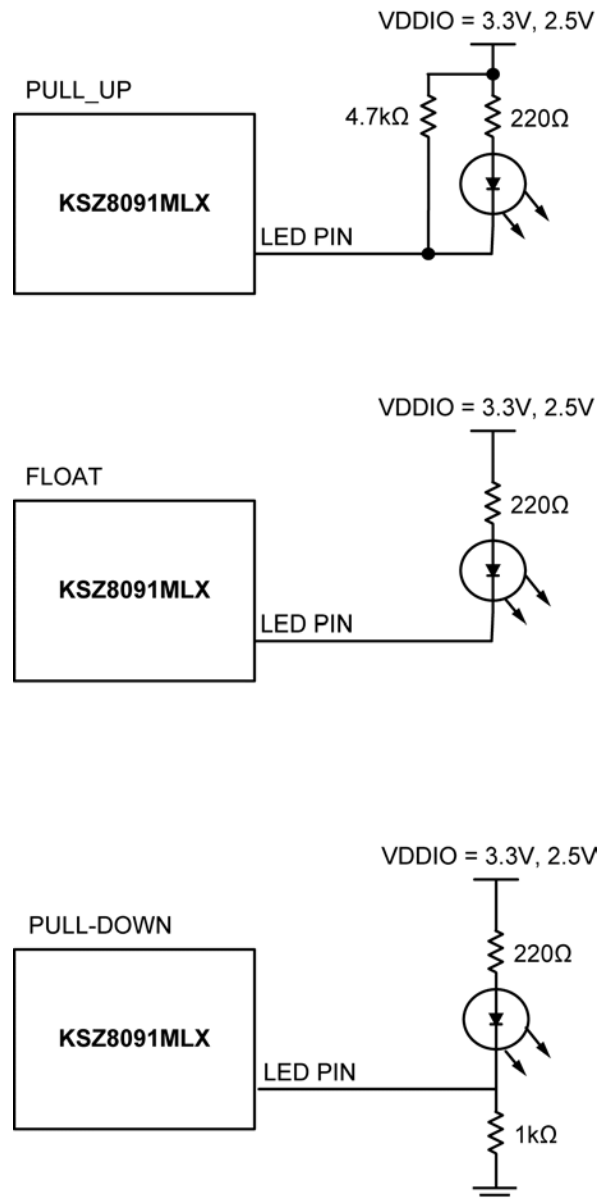

Figure 22. Reference Circuits for LED Strapping Pins

For 1.8V VDDIO, LED indication support is not recommended due to the low voltage. Without the LED indicator, the SPEED and NWAYEN strapping pins are functional with a 4.7kΩ pull-up to 1.8V VDDIO or float for a value of '1', and with a 1.0kΩ pull-down to ground for a value of '0'.

**Note:** If using RJ45 Jacks with integrated LEDs and 1.8V VDDIO, a level shifting is required from LED 3.3V to 1.8V. For example, use a bipolar transistor or a level shift device.

## Reference Clock – Connection and Selection

A crystal or external clock source, such as an oscillator, is used to provide the reference clock for the KSZ8091MLX.

For the KSZ8091MLX in all operating modes, the reference clock is 25MHz. The crystal / reference clock connections to XI (Pin 15) and XO (Pin 14), and the crystal / reference clock selection criteria, are provided in [Figure 23](#) and [Table 21](#).

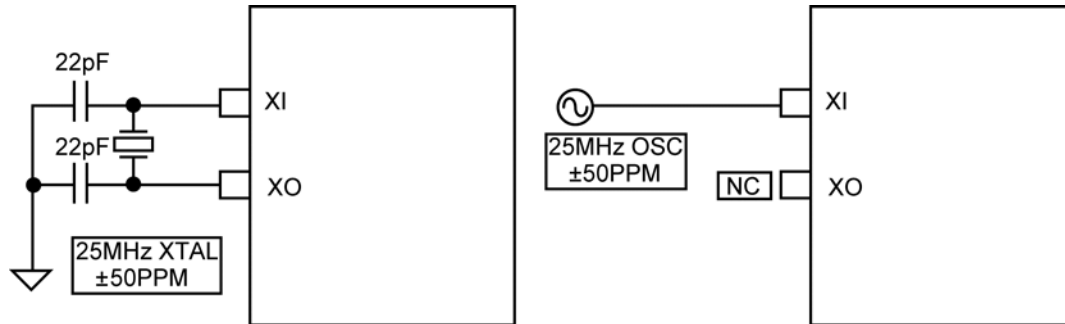

Figure 23. 25MHz Crystal/Oscillator Reference Clock Connection

Table 21. 25MHz Crystal / Reference Clock Selection Criteria

Characteristics	Value	Units
Frequency	25	MHz
Frequency tolerance (maximum) <sup>(13)</sup>	±50	ppm
Crystal series resistance (typical)	40	Ω
Crystal load capacitance (typical)	16	pF

**Note:**

13. ±60ppm for overtemperature crystal.

## Magnetic – Connection and Selection

A 1:1 isolation transformer is required at the line interface. Use one with integrated common-mode chokes for designs exceeding FCC requirements.

The KSZ8091MLX design incorporates voltage-mode transmit drivers and on-chip terminations.

With the voltage-mode implementation, the transmit drivers supply the common-mode voltages to the two differential pairs. Therefore, the two transformer center tap pins on the KSZ8091MLX side should not be connected to any power supply source on the board; instead, the center tap pins should be separated from one another and connected through separate 0.1µF common-mode capacitors to ground. Separation is required because the common-mode voltage is different between transmitting and receiving differential pairs.

Figure 24 shows the typical magnetic interface circuit for the KSZ8091MLX.

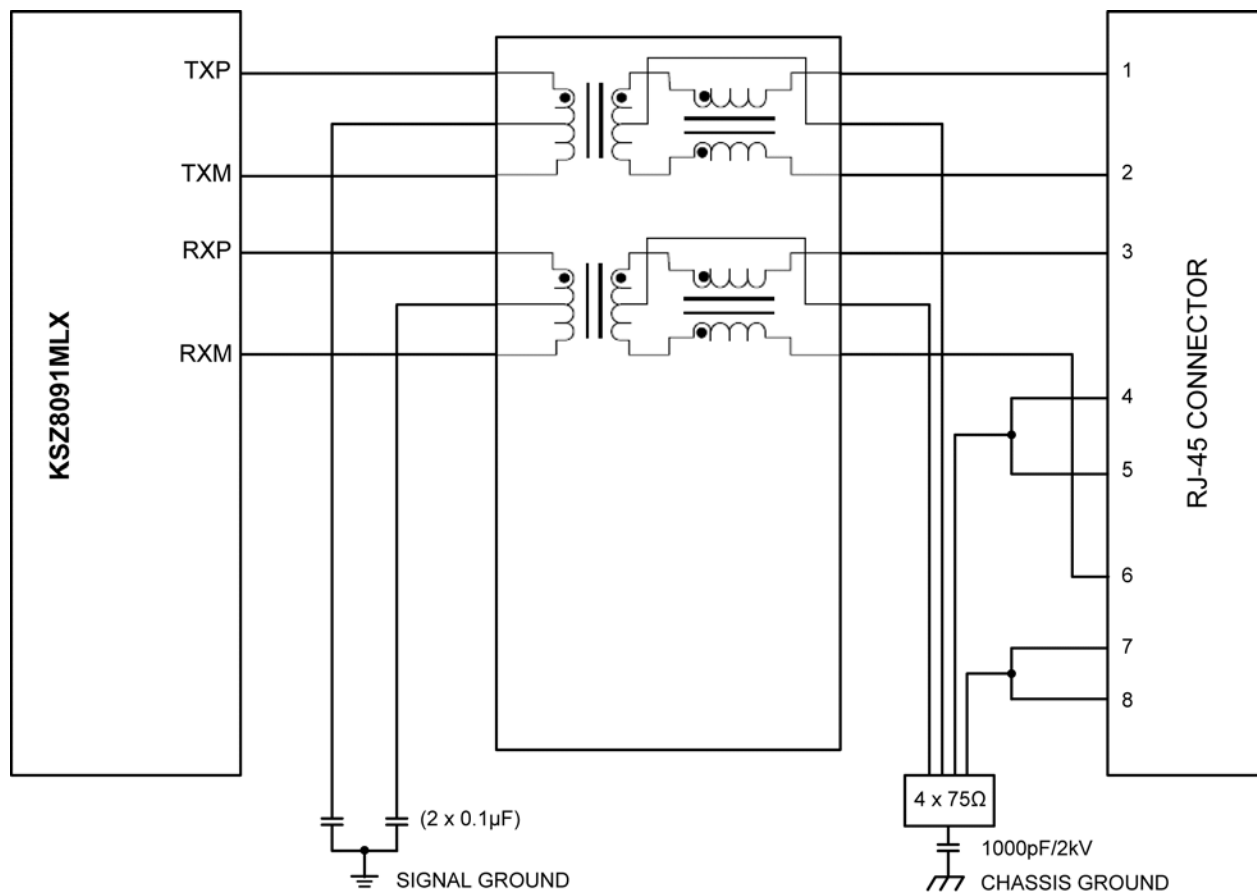

Figure 24. Typical Magnetic Interface Circuit

Table 22 lists recommended magnetic characteristics.

**Table 22. Magnetics Selection Criteria**

Parameter	Value	Test Condition
Turns ratio	1 CT : 1 CT	
Open-circuit inductance (min.)	350 $\mu$ H	100mV, 100kHz, 8mA
Insertion loss (typ.)	-1.1dB	100kHz to 100MHz
HIPOT (min.)	1500Vrms	

Table 23 is a list of compatible single-port magnetics with separated transformer center tap pins on the PHY chip side that can be used with the KSZ8091MLX.

**Table 23. Compatible Single-Port 10/100 Magnetics**

Manufacturer	Part Number	Temperature Range	Magnetic + RJ-45
Bel Fuse	S558-5999-U7	0°C to 70°C	No
Bel Fuse	SI-46001-F	0°C to 70°C	Yes
Bel Fuse	SI-50170-F	0°C to 70°C	Yes
Delta	LF8505	0°C to 70°C	No
HALO	HFJ11-2450E	0°C to 70°C	Yes
HALO	TG110-E055N5	-40°C to 85°C	No
LANKom	LF-H41S-1	0°C to 70°C	No
Pulse	H1102	0°C to 70°C	No
Pulse	H1260	0°C to 70°C	No
Pulse	HX1188	-40°C to 85°C	No
Pulse	J00-0014	0°C to 70°C	Yes
Pulse	JX0011D21NL	-40°C to 85°C	Yes
TDK	TLA-6T718A	0°C to 70°C	Yes
Transpower	HB726	0°C to 70°C	No
Würth/Midcom	000-7090-37R-LF1	-40°C to 85°C	No

Package Information<sup>(14)</sup> and Recommended Land Pattern

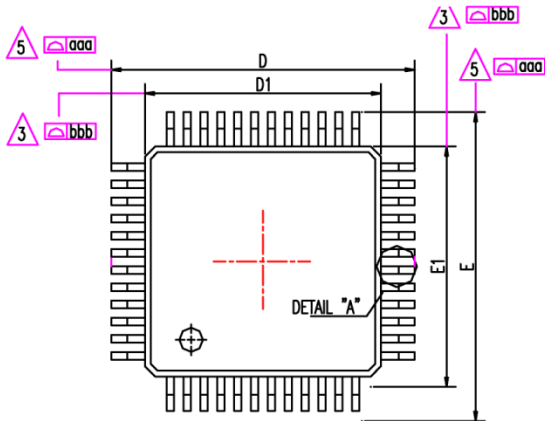

TOP VIEW

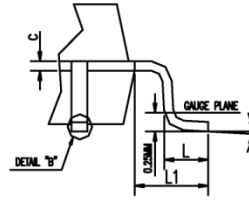

SIDE VIEW 1

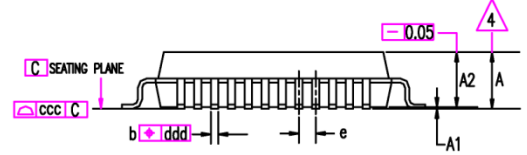

SIDE VIEW 2

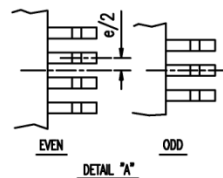

DETAIL "A"

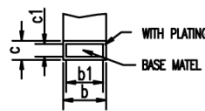

DETAIL "B"

SYMBOL	DIMENSION IN MM		
	MIN.	NOM.	MAX.
A	-	-	1.60
A1	0.05	-	0.15
A2	1.35	1.40	1.45
D	9.00 BSC		
D1	7.00 BSC		
E	9.00 BSC		
E1	7.00 BSC		
c	0.09	-	0.20
c1	0.09	-	0.16
L	0.45	0.60	0.75
L1	1.00 REF.		
θ	0	3.5	7

N	b (MM)			b1 (MM)			e (MM)		
	MIN.	NOM.	MAX.	MIN.	NOM.	MAX.	MIN.	NOM.	MAX.
48L	0.17	0.22	0.27	0.17	0.20	0.23	0.50 BSC.		

TOLERANCE OF FORM AND POSITION	
aaa	0.20
bbb	0.20
ccc	0.08
ddd	0.08

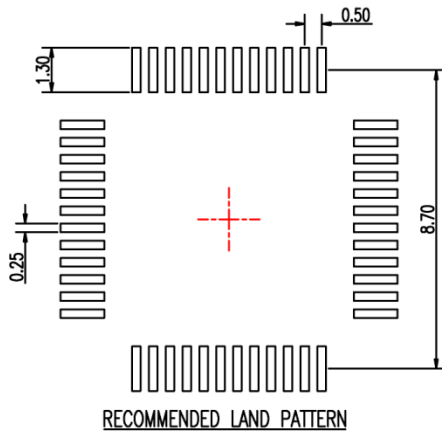

RECOMMENDED LAND PATTERN

NOTES:

- ALL DIMENSIONS ARE IN MM.
- REFER TO JEDEC STANDARD MS-026 BBC.
- DIMENSIONS "D1" AND "E1" DO NOT INCLUDE MOLD PROTRUSIONS. ALLOWABLE PROTRUSION IS 0.25mm PER SIDE. "D1" AND "E1" ARE MAXIMUM PLASTIC BODY SIZE DIMENSIONS INCLUDING MOLD MISMATCH.
- A1 IS DEFINED AS THE DISTANCE FROM THE SEATING PLANE TO THE LOWEST POINT OF THE PACKAGE BODY.
- TO BE DETERMINED AT SEATING DATUM PLANE C.
- "aaa" IS THE BILATERAL PROFILE TOLERANCE THAT CONTROLS THE POSITION OF THE PLASTIC BODY SIDES. THE CENTER OF THE PROFILE ZONES ARE DEFINED BY THE BASIC DIMENSIONS "D" AND "E".
- "bbb" THE TOLERANCE THAT CONTROLS THE POSITION OF THE ENTIRE TERMINAL PATTERN WITH RESPECT TO DATUM'S A AND B. THE CENTER OF THE TOLERANCE ZONE FOR EACH TERMINAL IS DEFINED BY THE BASIC DIMENSION "e" RELATED TO DATUM A AND B.
- "ccc" THE TOLERANCE RELATED TO THE SEATING PLANE IN WHICH THE TOP SURFACE OF THE PACKAGE MUST BE LOCATED.
- "ddd" THE TOLERANCE THAT CONTROLS THE POSITION OF THE TERMINALS TO EACH OTHER. THE CENTER OF THE PROFILE ZONES ARE DETERMINED BY THE BASIC DIMENSION "e".
- THIS DOCUMENT IS FOR AUTOMOTIVE PRODUCT USE ONLY.

48-Pin 7mm x 7mm LQFP (MM)

Note:

14. Package information is correct as of the publication date. For updates and most current information, go to [www.micrel.com](http://www.micrel.com).

---

**MICREL, INC. 2180 FORTUNE DRIVE SAN JOSE, CA 95131 USA**  
TEL +1 (408) 944-0800 FAX +1 (408) 474-1000 WEB <http://www.micrel.com>

Micrel, Inc. is a leading global manufacturer of IC solutions for the worldwide high-performance linear and power, LAN, and timing & communications markets. The Company's products include advanced mixed-signal, analog & power semiconductors; high-performance communication, clock management, MEMs-based clock oscillators & crystal-less clock generators, Ethernet switches, and physical layer transceiver ICs. Company customers include leading manufacturers of enterprise, consumer, industrial, mobile, telecommunications, automotive, and computer products. Corporation headquarters and state-of-the-art wafer fabrication facilities are located in San Jose, CA, with regional sales and support offices and advanced technology design centers situated throughout the Americas, Europe, and Asia. Additionally, the Company maintains an extensive network of distributors and reps worldwide.

Micrel makes no representations or warranties with respect to the accuracy or completeness of the information furnished in this datasheet. This information is not intended as a warranty and Micrel does not assume responsibility for its use. Micrel reserves the right to change circuitry, specifications and descriptions at any time without notice. No license, whether express, implied, arising by estoppel or otherwise, to any intellectual property rights is granted by this document. Except as provided in Micrel's terms and conditions of sale for such products, Micrel assumes no liability whatsoever, and Micrel disclaims any express or implied warranty relating to the sale and/or use of Micrel products including liability or warranties relating to fitness for a particular purpose, merchantability, or infringement of any patent, copyright, or other intellectual property right.

Micrel Products are not designed or authorized for use as components in life support appliances, devices or systems where malfunction of a product can reasonably be expected to result in personal injury. Life support devices or systems are devices or systems that (a) are intended for surgical implant into the body or (b) support or sustain life, and whose failure to perform can be reasonably expected to result in a significant injury to the user. A Purchaser's use or sale of Micrel Products for use in life support appliances, devices or systems is a Purchaser's own risk and Purchaser agrees to fully indemnify Micrel for any damages resulting from such use or sale.

© 2013 Micrel, Incorporated.