

## 2-Bit Universal Bi-directional Level Shifter with Automatic Direction Control & Advance Package Solution

### Features

- 1.2V to 3.6V on A Port and 1.65V to 5.5V on B Port ( $V_{CCA} \leq V_{CCB}$ )
- $V_{CC}$  Isolation Feature – If Either  $V_{CC}$  Input Is at GND, All Outputs Are in the High-Impedance State
- OE Input Circuit Referenced to  $V_{CCA}$
- Low Power Consumption, 5  $\mu$ A Max  $I_{CC}$
- $I_{off}$  Supports Partial-Power-Down Mode Operation
- Latch-Up Performance Exceeds 100mA Per JESD 78, Class II
- ESD Protection Exceeds JESD 22

#### A Port

- ◆2500-V Human-Body Model (A114-F)
- ◆200-V Machine Model (A115-A)
- ◆1500-V Charged-Device Model (C101D)

#### B Port

- ◆15-kV Human-Body Model (A114-F)
- ◆200-V Machine Model (A115-A)
- ◆1500-V Charged-Device Model (C101D)

### Description

This 2-bit non-inverting translator uses two separate configurable power-supply rails. The A port is designed to track  $V_{CCA}$ .  $V_{CCA}$  accepts any supply voltage from 1.2V to 3.6V. The B port is designed to track  $V_{CCB}$ .  $V_{CCB}$  accepts any supply voltage from 1.65V to 5.5V. This allows for universal low-voltage bidirectional translation between any of the 1.2V, 1.5V, 1.8V, 2.5V, 3.3V, and 5V voltage nodes.  $V_{CCA}$  should not exceed  $V_{CCB}$ .

When the output-enable (OE) input is low, all outputs are placed in the high-impedance state.

This device is fully specified for partial-power-down applications using  $I_{off}$ . The  $I_{off}$  circuitry disables the outputs, preventing damaging current backflow through the device when it is powered down.

To ensure the high-impedance state during power up or power down, OE should be tied to GND through a pull-down resistor; the minimum value of the resistor is determined by the current-sourcing capability of the driver.

### Pin Assignment

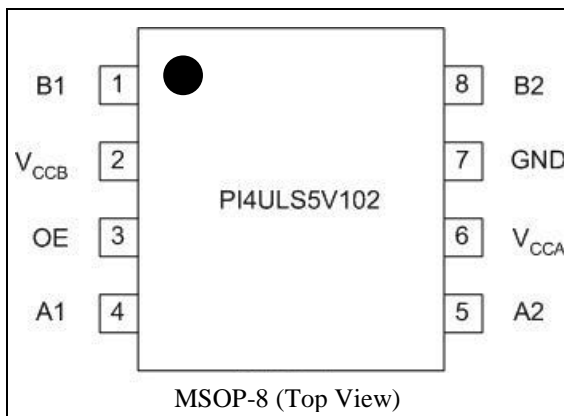
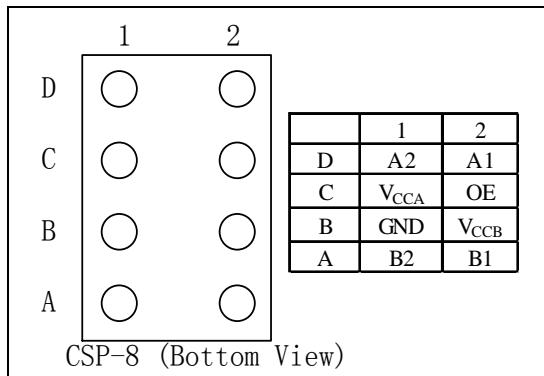

### Function Block Diagram

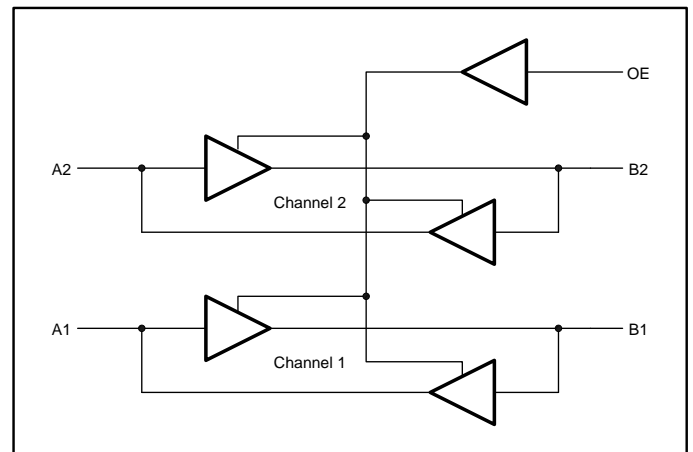

### Pin Description

Pin Name	Description
B1, B2	Input/output B. Referenced to $V_{CCB}$ .
GND	Ground.
$V_{CCA}$	A port supply voltage. $1.2\text{ V} \leq V_{CCA} \leq 3.6\text{ V}$ and $V_{CCA} \leq V_{CCB}$ .
A1, A2	Input/output A. Referenced to $V_{CCA}$ .
OE	3-State output. Pull OE low to place all outputs in 3-state mode. Referenced to $V_{CCA}$ .
$V_{CCB}$	B port supply voltage. $1.65\text{ V} \leq V_{CCB} \leq 5.5\text{ V}$ .



**Maximum Ratings**<sup>\*1</sup>

		Min	Max	Unit
V <sub>CCA</sub>	Supply voltage range	-0.5	4.6	V
V <sub>CCB</sub>		-0.5	6.5	
V <sub>I</sub>	Input voltage range	A port	4.6	V
		B port	6.5	
V <sub>O</sub>	Voltage range applied to any output in the high-impedance or power-off state	A port	4.6	V
		B port	6.5	
V <sub>O</sub>	Voltage range applied to any output in the high or low state <sup>*2</sup>	A port	V <sub>CCA</sub> + 0.5	V
		B port	V <sub>CCB</sub> + 0.5	
I <sub>IK</sub>	Input clamp current, V <sub>I</sub> < 0		-50	mA
I <sub>OK</sub>	Output clamp current, V <sub>O</sub> < 0		-50	mA
I <sub>O</sub>	Continuous output current		±50	mA
I <sub>O</sub>	Continuous current through V <sub>CCA</sub> , V <sub>CCB</sub> , or GND		±100	mA
T <sub>stg</sub>	Storage temperature range	-65	150	°C

\*1 Stresses greater than those listed under MAXIMUM RATINGS may cause permanent damage to the device. This is a stress rating only and functional operation of the device at these or any other conditions above those indicated in the operational sections of this specification is not implied. Exposure to absolute maximum rating conditions for extended periods may affect reliability.

\*2 The value of V<sub>CCA</sub> and V<sub>CCB</sub> are provided in the recommended operating conditions table.

**Recommend Operation Conditions**<sup>(1)(2)</sup>

Parameter	Description	V <sub>CCA</sub>	V <sub>CCB</sub>	Min	Max	Unit	
V <sub>CCA</sub>	Supply voltage	-	-	1.2	3.6	V	
V <sub>CCB</sub>		-	-	1.65	5.5		
V <sub>IH</sub>	High-level input voltage	Data inputs	1.2V to 3.6V	1.65V to 5.5V	V <sub>CCI</sub> <sup>*</sup> 0.65 <sup>(3)</sup>	V <sub>CCI</sub>	V
		OE input	1.2V to 3.6V	1.65V to 5.5V	V <sub>CCA</sub> <sup>*</sup> 0.7	5.5	
V <sub>IL</sub>	Low-level input voltage	Data inputs	1.2V to 3.6V	1.65V to 5.5V	0	V <sub>CCI</sub> <sup>*</sup> 0.35 <sup>(3)</sup>	V
		OE input	1.2V to 3.6V	1.65V to 5.5V	0	V <sub>CCA</sub> <sup>*</sup> 0.3	
V <sub>O</sub>	Voltage range applied to any output in the high-impedance or power-off state	A port	1.2V to 3.6V	1.65V to 5.5V	0	3.6	V
		B port	3.6V	5.5V	0	5.5	
Δt/Δv	Input transition rise or fall rate	A port inputs	1.2V to 3.6V	1.65V to 5.5V	-	40	ns/V
		B port inputs	1.2V to 3.6V	1.65V to 3.6V 4.5V to 5.5V	-	40 30	
T <sub>A</sub>	Operating free-air temperature	-	-	-40	85	°C	

(1) The A and B sides of an unused data I/O pair must be held in the same state, i.e., both at V<sub>CCI</sub> or both at GND.

(2) V<sub>CCA</sub> must be less than or equal to V<sub>CCB</sub> and must not exceed 3.6 V.

(3) V<sub>CCI</sub> is the supply voltage associated with the input port.

**DC Electrical Characteristics<sup>(1)(2)</sup>**

Parameter	Test Conditions	V <sub>CCA</sub>	V <sub>CCB</sub>	T <sub>A</sub> = 25°C			-40 to 85°C		Unit	
				Min	Typ	Max	Min	Max		
V <sub>OHA</sub>	I <sub>OH</sub> = -20μA	1.2V	-	1.0	1.1	1.2	-	-	V	
		1.4V to 3.6V		-	-	-	V <sub>CCA</sub> - 0.4	-		
V <sub>OLA</sub>	I <sub>OL</sub> = 20μA	1.2V	-	0.0	0.09	0.4	-	-	V	
		1.4V to 3.6V		-	-	-	-	0.4		
V <sub>OHB</sub>	I <sub>OH</sub> = -20μA	-	1.65V to 5.5V	-	-	-	V <sub>CCB</sub> - 0.4	-	V	
V <sub>OLB</sub>	I <sub>OL</sub> = 20μA	-	1.65V to 5.5V	-	-	-	-	0.4	V	
I <sub>I</sub>	OE	V <sub>I</sub> = V <sub>CC1</sub> or GND	1.2 to 3.6V	1.65V to 5.5V	-	-	±1	-	±2	μA
I <sub>off</sub>	A port	V <sub>I</sub> or V <sub>O</sub> = 0 to 3.6V	0V	0V to 5.5V	-	-	±1	-	±2	μA
	B port	V <sub>I</sub> or V <sub>O</sub> = 0 to 5.5V	0 to 3.6V	0V	-	-	±1	-	±2	
I <sub>OZ</sub>	A or B port	OE = GND	1.2 to 3.6V	1.65V to 5.5V	-	-	±1	-	±2	μA
I <sub>CCA</sub>	V <sub>I</sub> = V <sub>CC1</sub> or GND, I <sub>O</sub> = 0	1.2V	1.65V to 5.5V	0.0	0.06	5.0	-	-	μA	
		1.4V to 3.6V	1.65V to 5.5V	-	-	-	-	5		
		3.6V	0V	-	-	-	-	2		
		0V	5.5V	-	-	-	-	-2		
I <sub>CCB</sub>	V <sub>I</sub> = V <sub>CC1</sub> or GND, I <sub>O</sub> = 0	1.2V	1.65V to 5.5V	0	2.3	5.0	-	-	μA	
		1.4V to 3.6V	1.65V to 5.5V	-	-	-	-	5		
		3.6V	0V	-	-	-	-	-2		
		0V	5.5V	-	-	-	-	2		
I <sub>CCA</sub> + I <sub>CCB</sub>	V <sub>I</sub> = V <sub>CC1</sub> or GND, I <sub>O</sub> = 0	1.2V	1.65V to 5.5V	0.0	2.4	8.0	-	-	μA	
		1.4V to 3.6V	1.65V to 5.5V	-	-	-	-	8		
I <sub>CCZA</sub>	V <sub>I</sub> = V <sub>CC1</sub> or GND, I <sub>O</sub> = 0, OE = GND	1.2V	1.65V to 5.5V	0.0	0.05	0.4	-	-	μA	
		1.4V to 3.6V	1.65V to 5.5V	-	-	-	-	3		
I <sub>CCZB</sub>	V <sub>I</sub> = V <sub>CC1</sub> or GND, I <sub>O</sub> = 0, OE = GND	1.2V	1.65V to 5.5V	0.0	2.3	5.0	-	-	μA	
		1.4V to 3.6V	1.65V to 5.5V	-	-	-	-	5		
C <sub>i</sub>	OE	-	1.2 to 3.6V	1.65V to 5.5V	-	2.5	-	-	3	pF
C <sub>io</sub>	A port	-	1.2 to 3.6V	1.65V to 5.5V	-	5	-	-	6	pF
	B port	-			-	11	-	-	14	

(1) V<sub>CC1</sub> is the supply voltage associated with the input port.

(2) V<sub>CC0</sub> is the supply voltage associated with the output port.



## AC Electrical Characteristics

### Timing requirements

a.  $T_A = 25^\circ\text{C}$ ,  $V_{CCA} = 1.2\text{V}$

			$V_{CCB} = 1.8\text{V}$	$V_{CCB} = 2.5\text{V}$	$V_{CCB} = 3.3\text{V}$	$V_{CCB} = 5\text{V}$	Unit
			TYP	TYP	TYP	TYP	
Data rate			20	20	20	20	Mbps
$t_w$	Pulse duration	Data inputs	50	50	50	50	ns

b.  $T_A = 25^\circ\text{C}$ ,  $V_{CCA} = 1.5 \pm 0.1\text{V}$

			$V_{CCB} = 1.8 \pm 0.15\text{V}$		$V_{CCB} = 2.5 \pm 0.2\text{V}$		$V_{CCB} = 3.3 \pm 0.3\text{V}$		$V_{CCB} = 5 \pm 0.5\text{V}$		Unit
			MIN	MAX	MIN	MAX	MIN	MAX	MIN	MAX	
Data rate			-	40	-	40	-	40	-	40	Mbps
$t_w$	Pulse duration	Data inputs	25	-	25	-	25	-	25	-	ns

c.  $T_A = 25^\circ\text{C}$ ,  $V_{CCA} = 1.8 \pm 0.15\text{V}$

			$V_{CCB} = 1.8 \pm 0.15\text{V}$		$V_{CCB} = 2.5 \pm 0.2\text{V}$		$V_{CCB} = 3.3 \pm 0.3\text{V}$		$V_{CCB} = 5 \pm 0.5\text{V}$		Unit
			MIN	MAX	MIN	MAX	MIN	MAX	MIN	MAX	
Data rate			-	60	-	60	-	60	-	60	Mbps
$t_w$	Pulse duration	Data inputs	17	-	17	-	17	-	17	-	ns

d.  $T_A = 25^\circ\text{C}$ ,  $V_{CCA} = 2.5 \pm 0.2\text{V}$

			$V_{CCB} = 2.5 \pm 0.2\text{V}$		$V_{CCB} = 3.3 \pm 0.3\text{V}$		$V_{CCB} = 5 \pm 0.5\text{V}$		Unit
			MIN	MAX	MIN	MAX	MIN	MAX	
Data rate			-	100	-	100	-	100	Mbps
$t_w$	Pulse duration	Data inputs	10	-	10	-	10	-	ns

e.  $T_A = 25^\circ\text{C}$ ,  $V_{CCA} = 3.3 \pm 0.3\text{V}$

			$V_{CCB} = 3.3 \pm 0.3\text{V}$		$V_{CCB} = 5 \pm 0.5\text{V}$		Unit
			MIN	MAX	MIN	MAX	
Data rate			-	100	-	100	Mbps
$t_w$	10	-	10	-	10	-	ns

### Switching characteristics

a.  $T_A = 25^\circ\text{C}$ ,  $V_{CCA} = 1.2\text{V}$

Parameter	From (INPUT)	To (OUTPUT)	$V_{CCB} = 1.8\text{V}$	$V_{CCB} = 2.5\text{V}$	$V_{CCB} = 3.3\text{V}$	$V_{CCB} = 5\text{V}$	Unit
			TYP	TYP	TYP	TYP	
$t_{pd}$	A	B	6.9	5.7	5.3	5.5	ns
	B	A	7.4	6.4	6	5.8	
$t_{en}$	OE	A	0.2	0.2	0.2	0.2	$\mu\text{s}$
		B	0.2	0.2	0.2	0.2	
$t_{dis}$	OE	A	0.4	0.4	0.4	0.4	$\mu\text{s}$
		B	0.2	0.2	0.2	0.2	
$t_{rA}, t_{fA}$	A-port rise and fall times		4.2	4.2	4.2	4.2	ns
$t_{rB}, t_{fB}$	B-port rise and fall times		2.1	1.5	1.2	1.1	ns
$t_{SK(O)}$	Channel-to-channel skew		0.5	0.5	0.5	1.4	ns
Max data rate	-		20	20	20	20	Mbps



**PI4ULS5V102**  
**2-Bit Universal Bi-directional Level**  
**Shifter with Automatic Direction**  
**Control & Advance Package Solution**

b.  $T_A = 25^\circ\text{C}$ ,  $V_{CCA} = 1.5 \pm 0.1\text{V}$

Parameter	From (INPUT)	To (OUTPUT)	$V_{CCB}=1.8\pm0.15\text{V}$		$V_{CCB} = 2.5\pm0.2\text{V}$		$V_{CCB}=3.3\pm0.3\text{V}$		$V_{CCB} = 5\pm0.5\text{V}$		Unit
			MIN	MAX	MIN	MAX	MIN	MAX	MIN	MAX	
$t_{pd}$	A	B	1.4	12.9	1.2	10.1	1.1	10	0.8	9.9	ns
	B	A	0.9	14.2	0.7	12	0.4	11.7	0.3	13.7	
$t_{en}$	OE	A	-	0.5	-	0.5	-	0.5	-	0.5	$\mu\text{s}$
		B	-	0.5	-	0.5	-	0.5	-	0.5	
$t_{dis}$	OE	A	-	0.5	-	0.5	-	0.5	-	0.5	$\mu\text{s}$
		B	-	0.5	-	0.5	-	0.5	-	0.5	
$t_{rA}, t_{fA}$	A-port rise and fall times		1.4	5.1	1.4	5.1	1.4	5.1	1.4	5.1	ns
$t_{rB}, t_{fB}$	B-port rise and fall times		0.9	4.5	0.6	3.2	0.5	2.8	0.4	2.7	ns
$t_{SK(O)}$	Channel-to-channel skew		-	0.5	-	0.5	-	0.5	-	0.5	ns
Max data rate			40	-	40	-	40	-	40	-	Mbps

c.  $T_A = 25^\circ\text{C}$ ,  $V_{CCA} = 1.8 \pm 0.15\text{V}$

Parameter	From (INPUT)	To (OUTPUT)	$V_{CCB}=1.8\pm0.15\text{V}$		$V_{CCB}=2.5\pm0.2\text{V}$		$V_{CCB}=3.3\pm0.3\text{V}$		$V_{CCB}=5\pm0.5\text{V}$		Unit
			MIN	MAX	MIN	MAX	MIN	MAX	MIN	MAX	
$t_{pd}$	A	B	1.6	11	1.4	7.7	1.3	6.8	1.2	6.5	ns
	B	A	1.5	12	1.3	8.4	1	7.6	0.9	7.1	
$t_{en}$	OE	A	-	0.3	-	0.25	-	0.25	-	0.25	$\mu\text{s}$
		B	-	0.3	-	0.25	-	0.25	-	0.25	
$t_{dis}$	OE	A	-	0.5	-	0.5	-	0.5	-	0.5	$\mu\text{s}$
		B	-	0.5	-	0.5	-	0.5	-	0.5	
$t_{rA}, t_{fA}$	A-port rise and fall times		1	4.2	1	4.1	1	4.1	1	4.1	ns
$t_{rB}, t_{fB}$	B-port rise and fall times		0.9	4.5	0.6	3.2	0.5	2.8	0.4	2.7	ns
$t_{SK(O)}$	Channel-to-channel skew		-	0.5	-	0.5	-	0.5	-	0.5	ns
Max data rate			60	-	60	-	60	-	60	-	Mbps

d.  $T_A = 25^\circ\text{C}$ ,  $V_{CCA} = 2.5 \pm 0.2\text{V}$

Parameter	From (INPUT)	To (OUTPUT)	$V_{CCB}=2.5\pm0.2\text{V}$		$V_{CCB}=3.3\pm0.3\text{V}$		$V_{CCB}=5\pm0.5\text{V}$		Unit
			MIN	MAX	MIN	MAX	MIN	MAX	
$t_{pd}$	A	B	1.1	6.3	1.0	5.2	0.9	4.7	ns
	B	A	1.2	6.6	1.1	5.1	0.9	4.4	
$t_{en}$	OE	A	-	0.25	-	0.2	-	0.2	$\mu\text{s}$
		B	-	0.25	-	0.2	-	0.2	
$t_{dis}$	OE	A	-	0.5	-	0.4	-	0.35	$\mu\text{s}$
		B	-	0.5	-	0.4	-	0.35	
$t_{rA}, t_{fA}$	A-port rise and fall times		0.8	3.0	0.8	3.0	0.8	3.0	ns
$t_{rB}, t_{fB}$	B-port rise and fall times		0.7	3.0	0.5	2.8	0.4	2.7	ns
$t_{SK(O)}$	Channel-to-channel skew		-	0.5	-	0.5	-	0.5	ns
Max data rate			100	-	100	-	100	-	Mbps



e.  $T_A = 25^\circ\text{C}$ ,  $V_{CCA} = 3.3 \pm 0.3\text{V}$

Parameter	From (INPUT)	To (OUTPUT)	$V_{CCB}=3.3 \pm 0.3\text{V}$		$V_{CCB}=5 \pm 0.5\text{V}$		Unit
			MIN	MAX	MIN	MAX	
$t_{pd}$	A	B	0.9	4.7	0.8	4.0	ns
	B	A	1.0	4.9	0.9	3.8	
$t_{en}$	OE	A	-	0.2	-	0.2	$\mu\text{s}$
		B	-	0.2	-	0.2	
$t_{dis}$	OE	A	-	0.3	-	0.3	$\mu\text{s}$
		B	-	0.3	-	0.3	
$t_{rA}, t_{fA}$	A-port rise and fall times		0.7	2.8	0.7	2.8	ns
$t_{rB}, t_{fB}$	B-port rise and fall times		0.5	2.7	0.4	2.7	ns
$t_{SK(O)}$	Channel-to-channel skew		-	0.5	-	0.5	ns
Max data rate			100	-	100	-	Mbps

### Operating characteristics

Parameter	Test Conditions	$V_{CCA}$							Unit		
		1.2V	1.2V	1.5V	1.8V	2.5V	2.5V	3.3V			
		$V_{CCB}$									
		5V	1.8V	1.8V	1.8V	2.5V	5V	3.3V to 5.5V			
		TYP	TYP	TYP	TYP	TYP	TYP	TYP			
$C_{pdA}$	A-port input, B-port output.	$C_L=0$ , $f=10\text{ MHz}$ , $t_r = t_f=1\text{ ns}$ , $OE=V_{CCA}$ (outputs enabled)	7.8	10	9	8	8	8	9	pF	
	B-port input, A-port output.		12	11	11	11	11	11	11		
$C_{pdB}$	A-port input, B-port output.		38.1	28	28	28	29	30	30		
	B-port input, A-port output.		25.4	18	18	18	18	21	21		
$C_{pdA}$	A-port input, B-port output.		$C_L=0$ , $f=10\text{ MHz}$ , $t_r = t_f=1\text{ ns}$ , $OE=GND$ (outputs disabled)	0.01	0.01	0.01	0.01	0.01	0.01		0.01
	B-port input, A-port output.			0.01	0.01	0.01	0.01	0.01	0.01		0.01
$C_{pdB}$	A-port input, B-port output.			0.01	0.01	0.01	0.01	0.01	0.01		0.03
	B-port input, A-port output.			0.01	0.01	0.01	0.01	0.01	0.02		0.04



**Test circuit**

1> Load circuit for Max data rate, pulse duration propagation delay output rise and fall time measurement

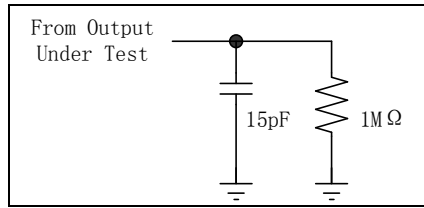

2> Load circuit for enable/disable time measurement

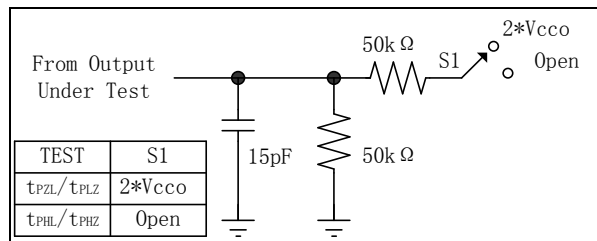

3> Timing Definitions for Propagation Delays and Enable/Disable Measurement

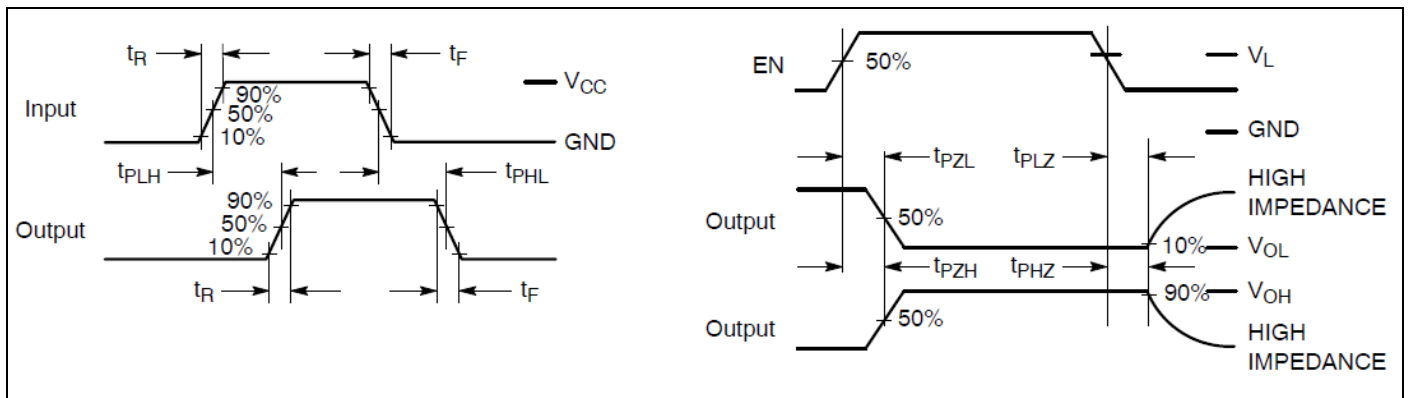

4> Voltage waveforms pulse duration

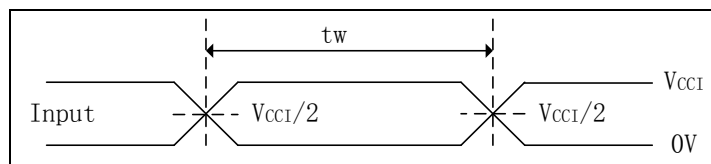

5> Notes

- A.  $C_L$  includes probe and jig capacitance.
- B. All input pulses are supplied by generators having the following characteristics: PRR\_10 MHz,  $Z_O = 50 \Omega$ ,  $dv/dt \geq 1 \text{ V/ns}$ .
- C. The outputs are measured one at a time, with one transition per measurement.
- D.  $t_{PLH}$  and  $t_{PHL}$  are the same as tpd.
- E.  $V_{CCI}$  is the  $V_{CC}$  associated with the input port.
- F.  $V_{CC0}$  is the  $V_{CC}$  associated with the output port.
- G. All parameters and waveforms are not applicable to all devices.

## Principles of operation

### Applications

The PI4ULS5V102 can be used in level-translation applications for interfacing devices or systems operating at different interface voltages with one another.

### Architecture

The PI4ULS5V102 architecture (see *Figure 1*) does not require a direction-control signal to control the direction of data flow from A to B or from B to A. In a dc state, the output drivers of the PI4ULS5V102 can maintain a high or low, but are designed to be weak, so that they can be overdriven by an external driver when data on the bus starts flowing the opposite direction.

The output one shots detect rising or falling edges on the A or B ports. During a rising edge, the one shot turns on the PMOS transistors (T1, T3) for a short duration, which speeds up the low-to-high transition. Similarly, during a falling edge, the one shot turns on the NMOS transistors (T2, T4) for a short duration, which speeds up the high-to-low transition. The typical output impedance during output transition is 70  $\Omega$  at  $V_{CC0}=1.2$  V to 1.8 V, 50  $\Omega$  at  $V_{CC0}=1.8$  V to 3.3 V, and 40  $\Omega$  at  $V_{CC0}=3.3$  V to 5 V.

### Input Driver Requirements

Typical  $I_{IN}$  vs  $V_{IN}$  characteristics of the PI4ULS5V102 are shown in *Figure 2*. For proper operation, the device driving the data I/Os of the PI4ULS5V102 must have drive strength of at least  $\pm 2$ mA.

### Power Up

During operation, ensure that  $V_{CCA} \leq V_{CCB}$  at all times. During power-up sequencing,  $V_{CCA} \geq V_{CCB}$  does not damage the device, so any power supply can be ramped up first. The PI4ULS5V102 has circuitry that disables all output ports when either  $V_{CC}$  is switched off ( $V_{CCA/B} = 0$  V).

### Enable and Disable

The PI4ULS5V102 has an OE input that is used to disable the device by setting OE = low, which places all I/Os in the high-impedance (Hi-Z) state. The disable time ( $t_{dis}$ ) indicates the delay between when OE goes low and when the outputs actually get disabled (Hi-Z). The enable time ( $t_{en}$ ) indicates the amount of time the user must allow for the one-shot circuitry to become operational after OE is taken high.

### Pull-up or Pull-down Resistors on I/O Lines

The PI4ULS5V102 is designed to drive capacitive loads of up to 70 pF. The output drivers of the PI4ULS5V102 have low dc drive strength. If pullup or pulldown resistors are connected externally to the data I/Os, their values must be kept higher than 50 k $\Omega$  to ensure that they do not contend with the output drivers of the PI4ULS5V102.

For the same reason, the PI4ULS5V102 should not be used in applications such as I2C or 1-Wire where an open-drain driver is connected on the bidirectional data I/O.



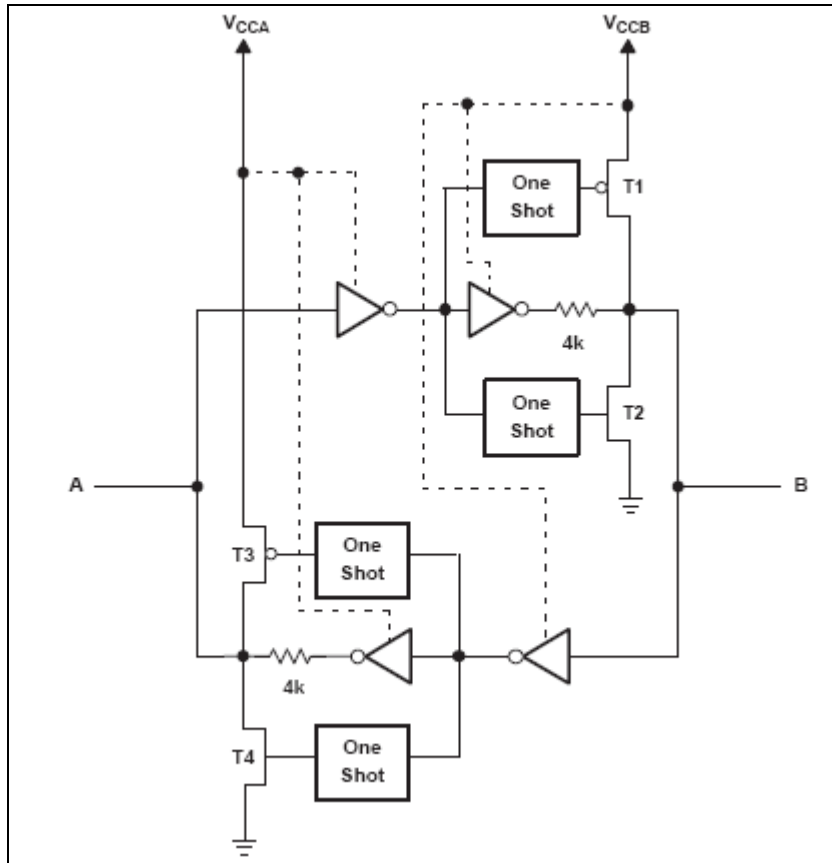

**Figure1. Architecture of PI4ULS5V102 I/O Cell**

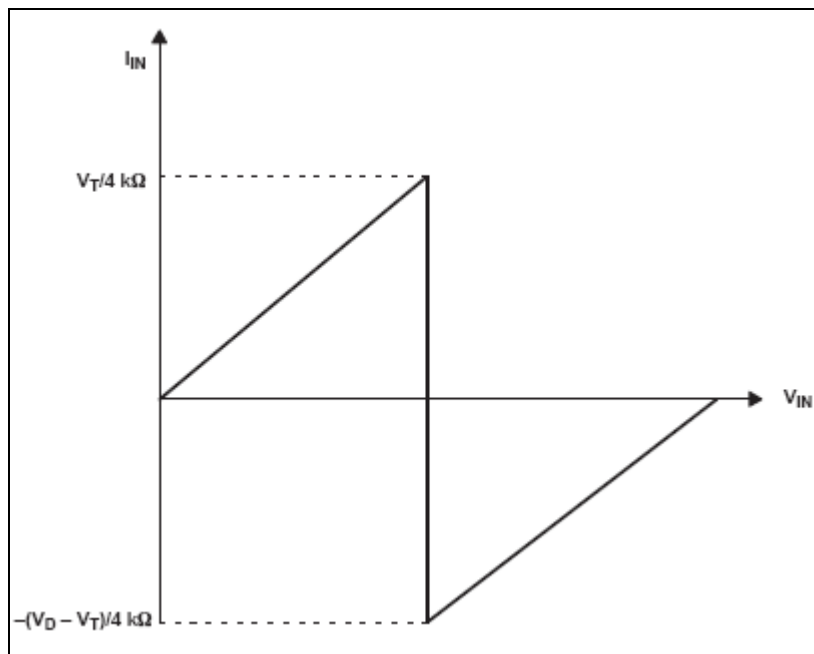

**Figure2. Typical  $I_{IN}$  vs  $V_{IN}$  Curve**

**Note:**

- A.  $V_T$  is the input threshold voltage of the PI4ULS5V102 (typically  $V_{CC}/2$ ).
- B.  $V_D$  is the supply voltage of the external driver.

**Mechanical Information**

CSP-8

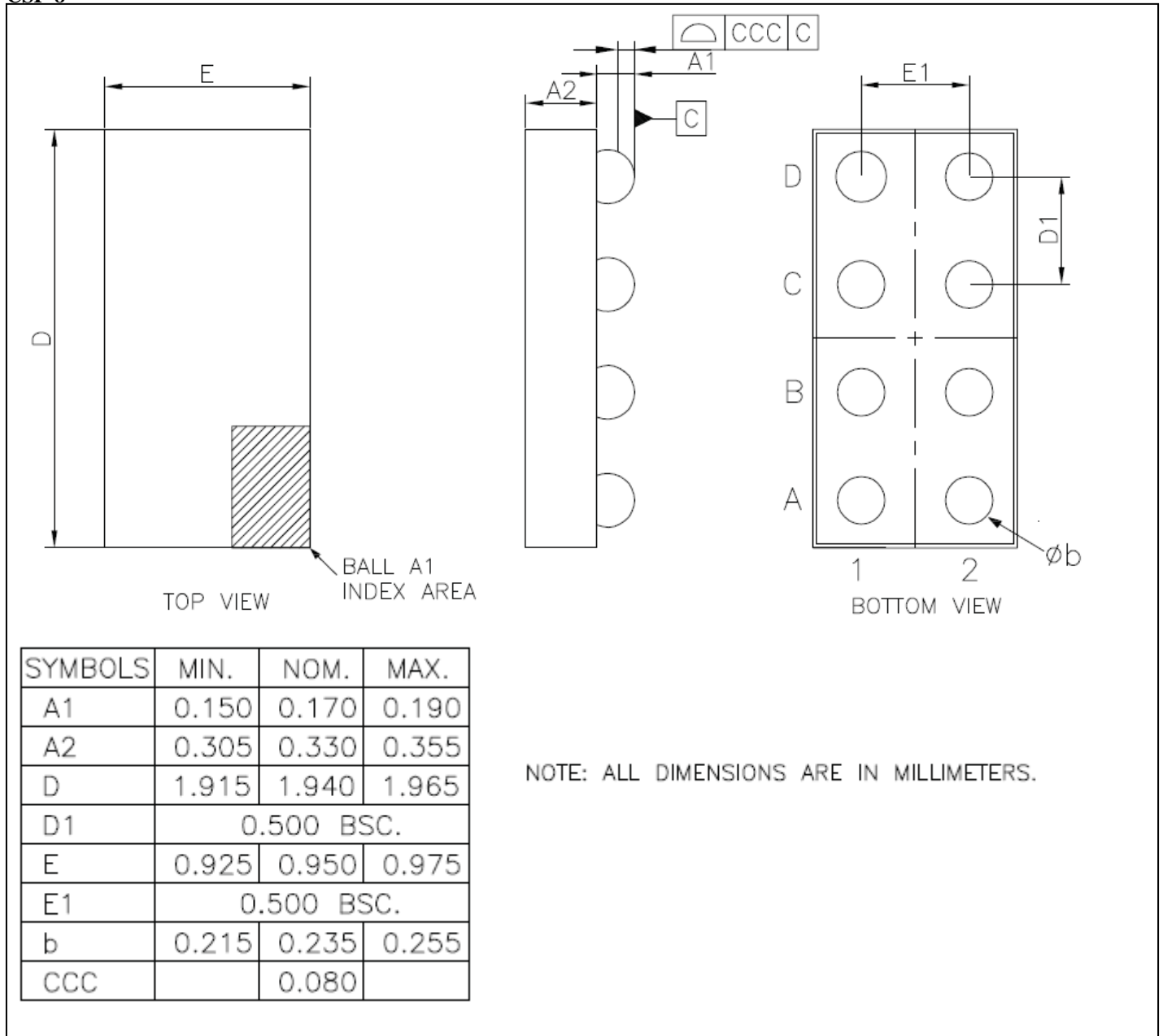



MSOP-8

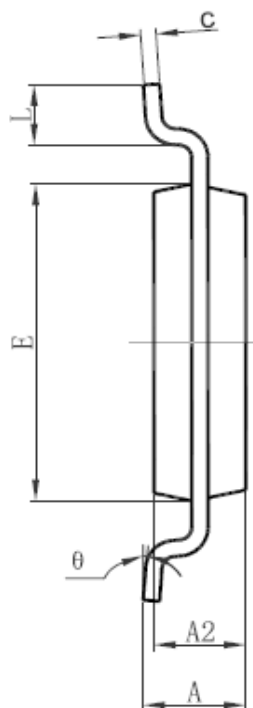
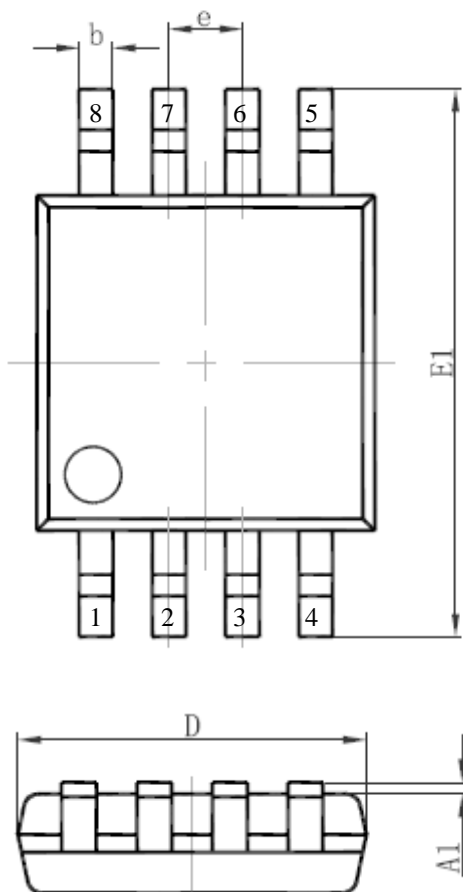

X.XX DENOTES DIMENSIONS IN MILLIMETERS

**Note:**

- 1) Controlling dimensions in millimeters.
- 2) Ref: JEDEC MO-187E/AA

Symbol	Dimensions In Millimeters		Dimensions In Inches	
	Min	Max	Min	Max
A	0.820	1.100	0.032	0.043
A1	0.020	0.150	0.001	0.006
A2	0.750	0.950	0.030	0.037
b	0.250	0.380	0.010	0.015
c	0.090	0.230	0.004	0.009
D	2.900	3.100	0.114	0.122
e	0.650(BSC)		0.026(BSC)	
E	2.900	3.100	0.114	0.122
E1	4.750	5.050	0.187	0.199
L	0.400	0.800	0.016	0.031
θ	0°	6°	0°	6°



## Ordering Information

Part Number	Package Code	Package
PI4ULS5V102GAE	GA	Lead free and Green 8-pin CSP
PI4ULS5V102UE	U	Lead free and Green 8-pin MSOP

**Notes:**

- E = Pb-free and Green
- Adding X Suffix= Tape/Reel