



Introduction

This document explains how to use the firmware stack protocol designed for an STM32F103xx microcontroller interfaced with an ST7540 FSK power line transceiver.

The firmware is organized in a layer structure and is able to drive the ST7540 transceiver, implementing a communication protocol for the data transfer between two or more devices connected to the same power line. The stack is also able to manage the possible conflicts, the data acknowledgement and the repetitions in the case of data loss.

This firmware stack is developed using the STM32F103xx Standard Peripherals Library Rel.3.5.0 and IAR Embedded Workbench IDE for STM32F103xx microcontrollers Rel. 6.3.

Contents

- 1 Network model description 4**
- 2 ST7540 stack firmware code 6**
 - 2.1 ST7540 driver layer 8
 - 2.1.1 PLM initialization 10
 - 2.1.2 Receiving data from power line modem 11
 - 2.1.3 Transmitting data to power line modem 11
 - 2.2 Data link and network level 12
 - 2.2.1 Stack initialization 16
 - 2.2.2 Stack data reception service (NL_NetworkIndication) 18
 - 2.2.3 Stack data transmission service (NL_NetworkRequest) 20
 - 2.2.4 Other stack interface APIs 21
- 3 Stack firmware structure 23**
- 4 References 25**
- 5 Revision history 26**

List of figures

Figure 1.	CSMA/CA	4
Figure 2.	Data exchange diagram	5
Figure 3.	Firmware structure of the power line modem	6
Figure 4.	Data communication flow with a case of repetition	7
Figure 5.	Firmware stack block diagram	8
Figure 6.	ST7540 driver structure	9
Figure 7.	Stack working mode bitmap definition	18
Figure 8.	Stack firmware structure	23

1 Network model description

The power line modem firmware stack is designed to manage a network structure composed of several power line modems, called nodes. These modem nodes are distributed throughout the power line. One or more modems can be used as a data concentrator and the others as slave modems. All the nodes and the concentrator share the same power line, which is used as a data communication channel (physical means).

The network is logically designed to be a master-slave structure, where the data concentrator is considered a master device and each addressed node is the slave. And, in fact, any device can initiate the communication, thereby becoming a master, while the target node, having a unique address ID, becomes the slave device.

Each node can also act as a data repeater, without any additional programming features, increasing both the reliability of the network and the statistical probability that the information from the master to the slave is delivered even under difficult network conditions.

However, the coexistence of more than one master and more repeaters introduces the need for data collision management. Since more than one device can initiate communication at any time, this may cause a network jam, lowering overall performance. This potential problem can be solved using one of two main techniques. One of these - carrier sense multiple access with collision detect (CSMA/CD) - is used when a hardware device is able to detect any collision during the data transmission. The other - carrier sense multiple access with collision avoidance (CSMA/CA) - the one used with this transceiver, is used when the hardware does not have this capability.

Figure 1. CSMA/CA

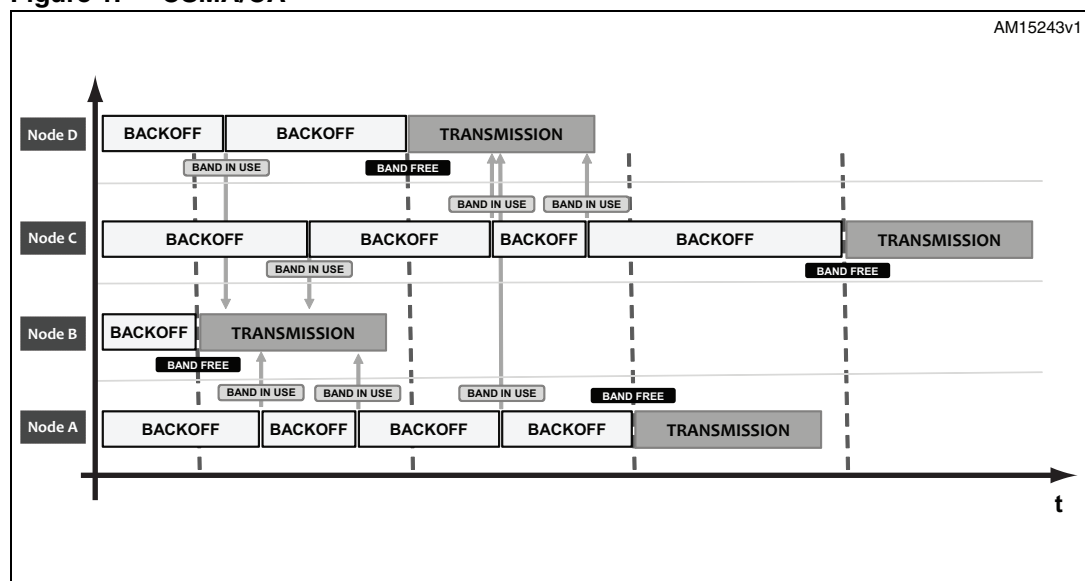

The implemented conflict avoidance mechanism uses a backoff time and the “band in use” (BU) hardware feature of the PLM to avoid transmission conflicts. Before initiating any communication, each device waits until the band is free by checking its own BU flag. As soon as the band is free, a random backoff time is calculated. Once the backoff time has elapsed, if the band is still free, the transmission is started, otherwise the loop is started again (waiting for the BU and new backoff calculation).

The data exchange between all the nodes connected to the same power line also uses a data frame acknowledgement mechanism. In this way, the master knows if its own transmitted data packet has been correctly delivered to the target node since it receives an acknowledgment frame for each data frame sent to a target device. This acknowledgement excludes some data frames sent in broadcast by the master.

Figure 2. Data exchange diagram

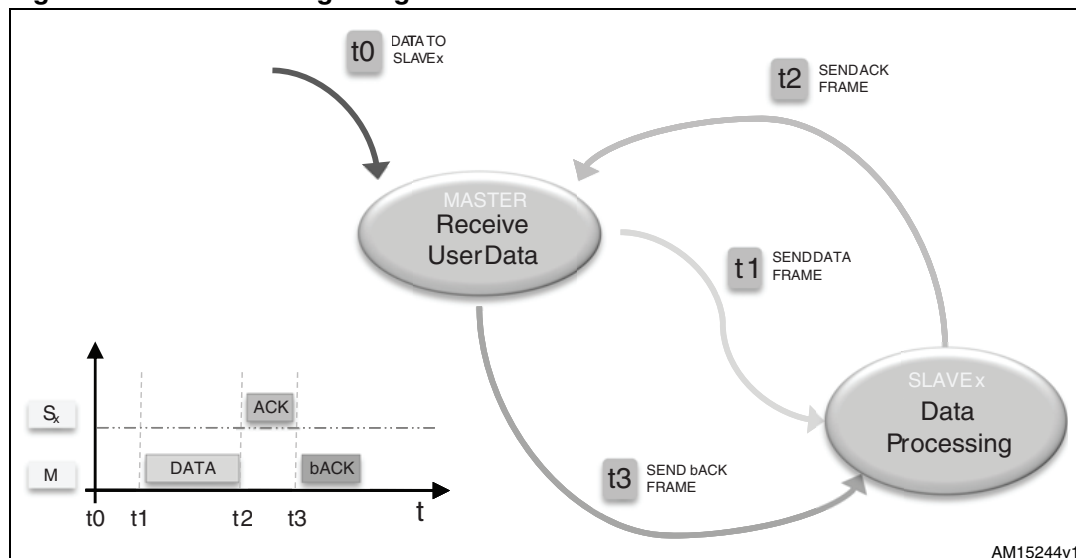

The repetition feature improves the probability that the data frame is delivered to nodes that are far away or under noisy network environments. As all the other nodes are connected in the same power line, they continuously sense the network catching all data transiting on it. Depending on the device addressing and the data frame/acknowledge flow, each node is able to detect if the sensed frame must be repeated, discharged, or processed. A data identification technique (frame ID) and the forward error correction redundancy (FEC) in the data frames are implemented in order to avoid cyclic repetitions or data loss that can cause an unnecessary increase of data traffic.

2 ST7540 stack firmware code

The firmware implementing the network model previously described is structured in several layers, each one performing different operations.

Figure 3. Firmware structure of the power line modem

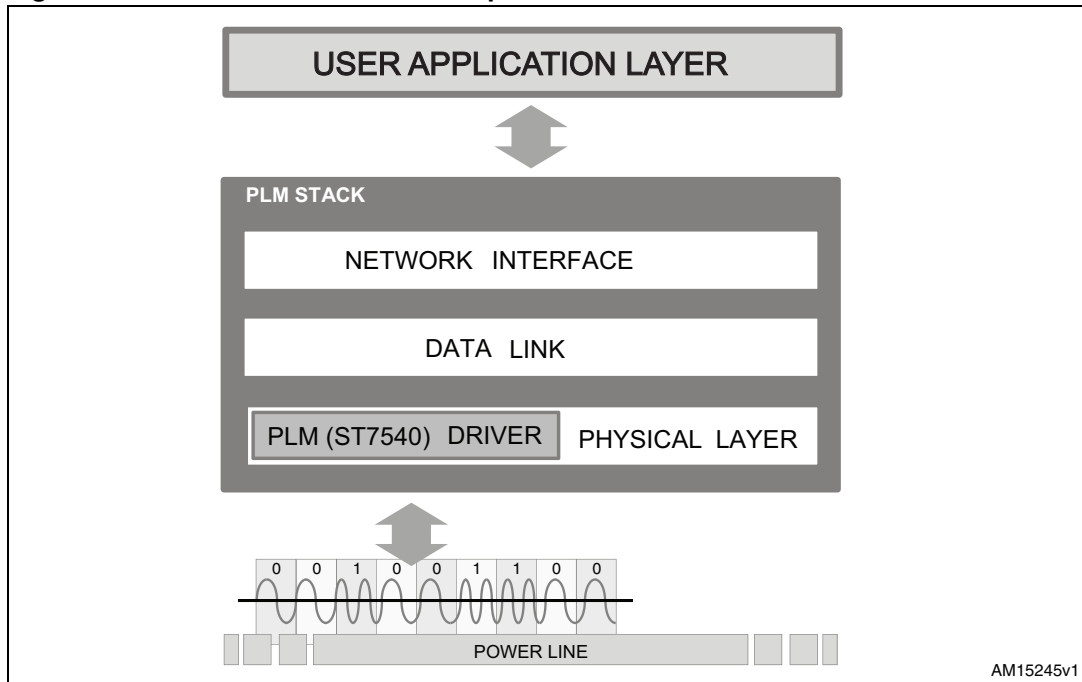

There are three types of frame that can be sent to the power line modem. The first are data frames, which contain the user data to send. The second are programming frames, which normally contain the programming parameters of the node, like the node unique address or other user defined programming parameters, normally used when the node is set up using external software (such as a graphical user interface) or an external device. The last are service frames, which contain parameters as well as the PLM stack parameters including timing and data repetitions, or user defined service parameters. The service frames also include parameters that set the node working model which are dependent on the network model to implement (for example, with or without acknowledgement, broadcast behavior, repetition mode).

In any case, each frame type here described is treated in the same manner by the stack, and transferred to/from the user application layer from/to the power line modem. A particular frame is the ping frame which is used to ping a remote node. As well as the remote node receiving these kinds of frames, the acknowledgement is given directly by the stack engine without notification to the upper levels. The same behavior is done with the acknowledgement frames (ACK and bACK) to the data, service or programming frames, which are managed directly by the stack.

In the PLM stack level, the user information is packed and added with the necessary information such as FEC and cyclic redundancy check - CRC, and sent to the PLM. This works both ways; if the PLM catches proper data packets, these are managed by the stack.

The FEC is used to correct wrong data (if any), the CRC is also checked, and if valid data are decoded, these are sent to the user application level. The PLM stack directly manages the repetitions, the necessary timing and acknowledgements.

If the target device does not acknowledge a data frame, each neighboring node, with the repetition feature enabled, that has sensed the transited data frame, forwards it, after the acknowledge timeout, as long as the band is not already taken. This repetition mechanism, managed directly by the PLM stack engine, is done once per node until either the data frame is acknowledged or each node has repeated the data frame. The repetition mechanism is also implemented for the acknowledgement frame, when not received by the master.

Figure 4. Data communication flow with a case of repetition

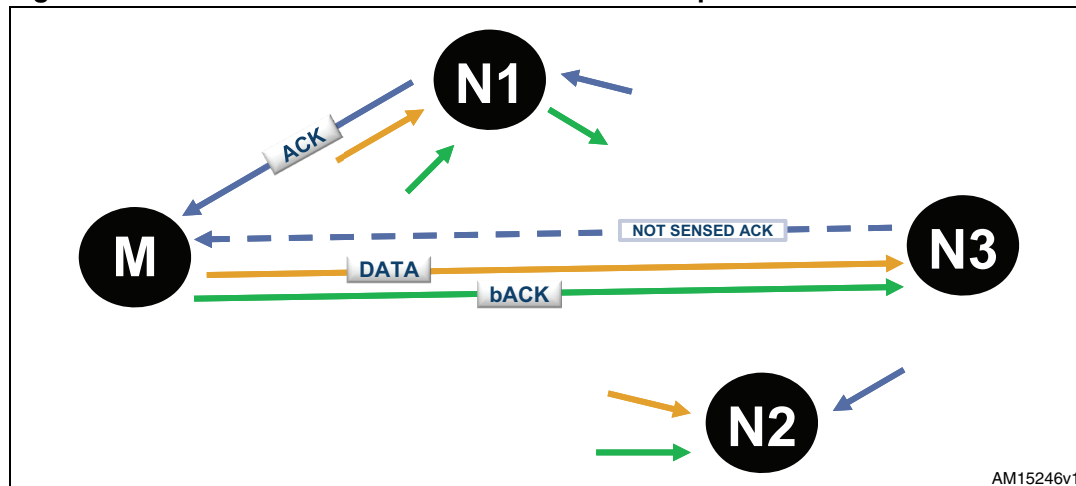

As each firmware layer adds its own information to the original frame, 100 bytes of user data from the application level become more than double that at the power line level. This is mainly because of the FEC redundancy added to each byte as soon as it arrives at a target node. Network traffic is therefore reduced if the power line is not overly noisy because the FEC algorithm can adjust the corrupted information.

Each frame also contains the target address, the source address, and other parameters. These may include a flag byte indicating the network model (the flag indicates if the repetition must be ignored for this frame, or if the acknowledge is awaited), a frame ID to avoid multiple repetitions of the same frame, the CRC (CRC16) bytes, the modem preamble, the header and the postamble byte.

Another implemented mechanism related to repetitions is 'hopping.' The hop level is one of the user-defined PLM parameters and is employed to assign a certain hierarchy in the repetition. If a frame must be repeated but the hop level is lower than the one stored in the stack parameter, the frame is not forwarded. Normally, the hierarchy is set depending on the distance and the ambient noise condition. The closer the repetition-enabled node is to the concentrator, the higher the hop level, and in this way, the traffic of insignificant repetitions is reduced.

Network grouping is another feature that can be implemented by the user. If implemented, the first two bytes of any frame address, which is 6 bytes long, are considered the group address. Each frame with a group address different from the assigned group is ignored. In this way it is possible that more than one network can share the same power line without interacting with each other.

The data structure is the following:

```
typedef struct
{
    /* Interrupt priorities */
    uint8_t  PLM_SPI_PreemptPriority;
    uint8_t  PLM_SPI_SubPriority;
    uint8_t  PLM_CDPD_PreemptPriority;
    uint8_t  PLM_CDPD_SubPriority;
}PLM_IntPriorityInitTypeDef;
```

Figure 6. ST7540 driver structure

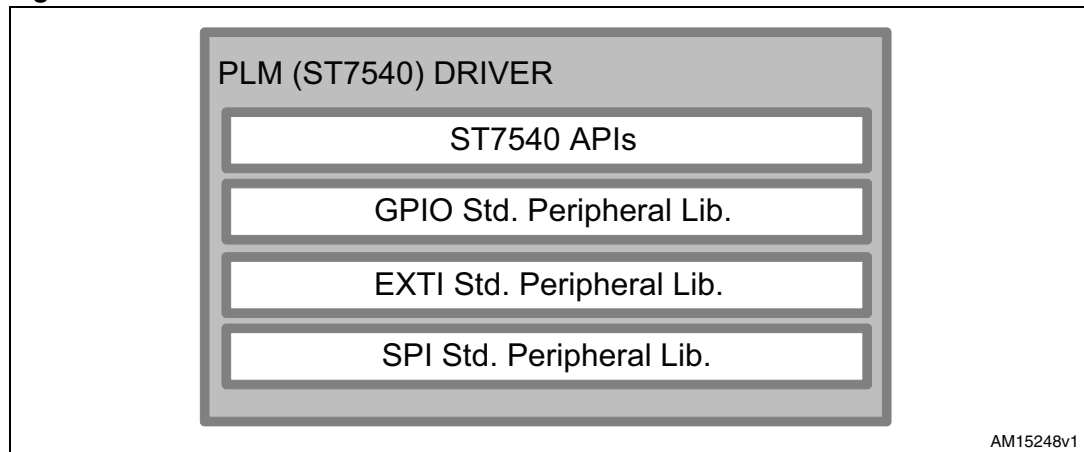

Next, the ST7540 is configured and programmed by the following function:

```
void PLM_Init(PLM_InitTypeDef *PLM_InitStruct);
```

This routine sets up all the modem parameters and initializes its internal registers. The structure passed to the API is the following:

```
typedef struct
{
    PLMFreq_TypeDef          PLM_BandpassFrequency;
    PLMBaudrate_TypeDef      PLM_BaudRate;
    uint16_t                 PLM_HeaderPreamble;
    PLMDeviation_TypeDef     PLM_Deviation;
    PLMPrefilter_TypeDef     PLM_PreFilter;
    PLMSensitivity_TypeDef   PLM_Sensitivity;
}PLM_InitTypeDef;
```

In the `stm32f10x_plm.h` file all the typedefs of the previous structure with the admitted values for the PLM parameters are defined.

The following APIs are used for the ST7540 peripheral management, and are the starting point for implementing its own stack firmware.

The first group returns some flags indicating if the band is in use by another device, if the current data frame has been sent or a data frame is received and if the received frame is a valid frame.

```
uint8_t      PLM_BandInUse(void);
uint8_t      PLM_FrameSent(void);
uint8_t      PLM_FrameArrived(void);
uint8_t      PLM_ValidFrameArrived(void);
```

The next group of APIs is used to send and receive a data frame.

```
void         PLM_SendData(uint8_t *buffer, uint8_t len);
void         PLM_StartReceiveData(void);
uint8_t      PLM_GetBufferLength(void);
uint8_t*     PLM_GetReceivedBufferPointer(void);
```

There are also some APIs used for low level statistics, returning the number of FEC corrections done in the arrived frame and the wrong postamble indication.

```
uint8_t      PLM_GetFECCorrections(void);
PLM_WP_TypeDef PLM_GetWrongPostamble(void);
```

The last group of driver APIs are used for the PLM reset and internal register write/read operations.

```
void         PLM_Reset(void);
void         PLM_WriteRegisters(uint8_t *buffer, uint8_t len);
void         PLM_StartReadRegisters(void);
```

2.1.1 PLM initialization

In this section, the instructions sequence on how to configure and use the ST7540 driver is shown.

First, the PLM must be initialized and configured by filling the init structures:

```
PLM_IntPriorityInitTypeDef PLM_InterruptInitStructure;
PLM_InitTypeDef PLM_InitStructure;
```

Configuring the PLM device and setting the correct interrupt priorities defined in the macros `PLM_SPI_INT_PREEMPTY_PRIORITY` and `PLM_SPI_INT_SUB_PRIORITY` for the SPI and `PLM_CDPD_PREEMPTY_PRIORITY` and `PLM_CDPD_SUB_PRIORITY` for the CDPD external interrupt pin, is done with the instructions:

```
PLM_InterruptInitStructure.PLM_SPI_PreemptPriority =
PLM_SPI_INT_PREEMPTY_PRIORITY;
PLM_InterruptInitStructure.PLM_SPI_SubPriority = PLM_SPI_INT_SUB_PRIORITY;
PLM_InterruptInitStructure.PLM_CDPD_PreemptPriority =
PLM_CDPD_PREEMPTY_PRIORITY;
PLM_InterruptInitStructure.PLM_CDPD_SubPriority = PLM_CDPD_SUB_PRIORITY;
PLM_PeripheralInit(&PLM_InterruptInitStructure);
```

The PLM parameters configuration, assigning the wanted values, is done with the code shown here below. In this example, PLM is configured with a bandpass filter of 132.5 KHz, a data baud rate of 2400 bps, deviation of 0.5 and high sensitivity with the prefilter on. Please refer to the ST7540 datasheets for more details on PLM parameters.

```

PLM_InitStructure.PLM_HeaderPreamble = HEADER_PREAMBLE_VALUE;
PLM_InitStructure.PLM_BandpassFrequency = PLM_PB_FREQ_132KHz;
PLM_InitStructure.PLM_BaudRate = PLM_BAUDRATE_2400;
PLM_InitStructure.PLM_Deviation = PLM_DEVIATION_05;
PLM_InitStructure.PLM_PreFilter = PLM_PRE_FILTER_ON;
PLM_InitStructure.PLM_Sensitivity = PLM_SENSITIVITY_HIGH;

```

In order to load the parameters, initialize the PLM variables, reset and put the device in IDLE mode, the following APIs must be used:

```

PLM_Init(&PLM_InitStructure);
PLM_Reset();

```

2.1.2 Receiving data from power line modem

The following API enables the PLM to receive data from the power line. As soon as a data frame is received, before receiving the next data frame, the function must be called again:

```
void PLM_StartReceiveData(void);
```

The next instruction notifies when a data frame has arrived and is ready to be read.

```

if (PLM_FrameArrived())
{
    ...
}

```

Another instruction can be used instead to test if a data frame is ready in the PLM buffer, and if this is the case, it automatically removes the header and the redundancy (FEC), and checks if the data frame has a correct postamble. The data reception is automatically enabled by this API if the frame is rejected.

```

if (PLM_ValidFrameArrived())
{
    ...
}

```

If valid data has arrived, the data length and the received data buffer are recovered by the following APIs:

```

/* Recover received data frame length */
uint8_t plm_len = PLM_GetBufferLength();

/* Points to PLM data buffer */
uint8_t *plm_buffer = PLM_GetReceivedBufferPointer();

```

2.1.3 Transmitting data to power line modem

Before transmitting data, the user should check if the band is already in use (this can happen if another device is transmitting data and the PLM detects a header sequence).

```

if (!PLM_BandInUse())
{
    ...
}

```

The buffer is then filled with the data to send and the correct buffer length is set:

```
/* Max payload size is 100 bytes. Do not exceeds this value */
uint8_t buffer[PAYLOAD_SIZE + LL_HDR_SIZE];
uint8_t len;
```

LL_HDR_SIZE is the size of some extra bytes added by the upper levels when a stack is used. Send the user bytes and wait until the transmission is completed using the following code (in this firmware release, the value of LL_HDR_SIZE is 19 bytes).

```
/* Send data throughout PL */
void PLM_SendData(uint8_t *buffer, uint8_t len);

/* Wait frame transmission. Manage timeout eventually or use this API in a
state machine */
while (!PLM_FrameSent());
...
```

Some other APIs can be used for statistics, or for testing the PL performance or any other use, and for the ST7540 internal register direct access.

```
/* Get the number of FEC correction for the arrived frame */
uint8_t PLM_GetFECCorrections(void);

/* Get the postamble status for the arrived frame */
PLM_WP_TypeDef PLM_GetWrongPostamble(void);

/* Write a buffer of len bytes in the ST7540 internal registers */
void PLM_WriteRegisters(u8 *buffer, u8 len);

/* Enable the ST7540 internal registers reading (use the PLM_FrameArrived()
function to test the data arrived flag) */
void PLM_StartReadRegisters(void);
```

2.2 Data link and network level

The data link layer implements the core of the stack protocol described at the beginning of this section. The stack is designed to work in a state machine firmware flow; this means that in a `while(1)` loop or in a task routine called by a timer or any other synchronous periodic event of the user application level, the stack engine update function must be called in order to update all the events and perform the consequent actions.

The interface between the user application layer and the stack link layer is the network layer. All the interface API definitions are in the `stk_n.h` file.

The stack engine update is done by using the `NL_DeviceStackUpdate` function in a non-blocking firmware flow:

```
void main(void)
{
    /* Application initialization */
    ...

    /* Infinitive loop */
    while(1)
    {
        /* User application state machine */
        USER_ApplicationSMupdate();

        ...

        /* Stack engine update */
        NL_DeviceStackUpdate();
    }
}
```

or, using an asynchronous (from the program flow) interrupt event of a timer or another peripheral or external device (RTC for example):

```
void main(void)
{
    /* Application initialization */
    ...

    /* User application code */
    ...
}

/* Internal timer, task event, periodic external event... */
void Timer_InterruptRequest(void)
{
    ...
    /* Stack engine update */
    NL_DeviceStackUpdate();
}
```

In the `interfaceconfig.h` file all the macros that represent the default configuration for the chosen working model and the stack parameters are defined. All the parameters and the configuration can be set in run mode using the appropriate APIs described hereinafter.

The stack working mode configuration parameters defined in the `interfaceconfig.h` file are shown below. In order to disable the corresponding option, it is necessary to comment (//) the equivalent macro.

```

/*-----*/
/* WORKING MODE DEFINITION */
/*-----*/
/* Comment the definition to disable the equivalent option */

/* Use the internal RTC */
#define DEVICE_USE_RTC
/* Use the external 32KHz oscillator for RTC functions */
#define DEVICE_USE_EXTOSC_32KHZ
/* Enable the internal watchdog for auto-reset */
#define DEVICE_USE_WATCHDOG
/* Enable the internal oscillator calibration (if external oscillator is
not used) */
//#define DEVICE_LSI_TIM_MEASURE
/* Enable the ACK frames transmission (link stack level) */
#define DEVICE_WM_REQ_ACK
/* Enable the back ACK frames transmission (link stack level) */
#define DEVICE_WM_REQ_BACK
/* Enable the repeater mode */
#define DEVICE_WM_REPEATER
/* Enable to repeat all frames after the ACK timeout (static repeater
behaviour, previous option must be enabled too) */
//#define DEVICE_WM_REPEAT_ALL
/* Enable the AES128 data encryption */
#define DEVICE_WM_ENCRYPT_DATA
/* Enable the grouping filter for subnets */
//#define DEVICE_WM_GROUP_FILTER
/* Hoping (commented, 0 or 1 = disabled, higher value = higher level.
Minimum allowed value = 2) */
//#define DEVICE_HOP_LEVEL

```

The following parameters set up the configuration mode of the transceiver. It's important to set the PLM communication frequency at the same value of the middle frequency of the bandpass filter used in the hardware.

```

/* PLM communication frequency */
//#define PLM_FREQ_60KHZ // PLM comm. frequency set to 60 KHz
//#define PLM_FREQ_66KHZ // PLM comm.frequency set to 66 KHz
//#define PLM_FREQ_72KHZ // PLM comm.frequency set to 72 KHz
//#define PLM_FREQ_76KHZ // PLM comm.frequency set to 76 KHz
//#define PLM_FREQ_82KHZ // PLM comm.frequency set to 82.05 KHz
//#define PLM_FREQ_86KHZ // PLM comm.frequency set to 86 KHz
//#define PLM_FREQ_110KHZ// PLM comm.frequency set to 110 KHz
#define PLM_FREQ_132KHZ // PLM comm.frequency set to 132.6 KHz

/* PLM interface communication baudrate */

```

```

// #define PLM_600_BPS // PLM communication baudrate 600 bps
// #define PLM_1200_BPS // PLM communication baudrate 1200 bps
#define PLM_2400_BPS // PLM communication baudrate 2400 bps
// #define PLM_4800_BPS // PLM communication baudrate 4800 bps

/* PLM Sensitivity */
#define PLM_SENS_HIGH // High sensitivity
// #define PLM_SENS_NORMAL // Normal sensitivity

```

The stack parameters defined in the `interfaceconfig.h` file are explained here below.

```

/*-----*/
/* DEFAULT LINK LAYER STACK DATA VALUES - <!> MODIFY WITH CARE */
/*-----*/

/* Minimum time slot for the back off time */
#define DEFAULT_MIN_SLOT 3 // 300 us
/* Maximum time slot for the back off time */
#define DEFAULT_MAX_SLOT 500 // 50 ms
/* Timeout for complete the communication (20sec - 10sec step) */
#define DEFAULT_NTW_P_GLOBAL_TX_TO 2 // 20s
/* Timeout for broadcast frame retransmission (10sec step) */
#define DEFAULT_NTW_P_BC_GLOBAL_TX_TO 2 // 20s
/* Timeout for network inactivity (must be > NTW_P_ACK_RX_TO) */
#define DEFAULT_NTW_P_ACTIVITY_TO 20000 // 2s
/* Communication watchdog timeout */
#define DEFAULT_NTW_P_WATCHDOG_TO 6 // 1min
/* Timeout for completing a datatransfer (one way) */
#define DEFAULT_NTW_P_DATATRANSFER_TO 10 // 10s
/* Timeout for band in use (0 = no timeout check) */
#define DEFAULT_NTW_P_BANDINUSE_TO 0 // (100us step)
/* Timeout for sending a frame through SPI */
#define DEFAULT_NTW_P_FRAME_TX_TO 12000 // 1.2s
/* Timeout for repeat a broadcast frame */
#define DEFAULT_NTW_P_BCAST_TX_TO 150000 // 15s
/* Timeout for receiving an ACK {@2400bps PLM speed (worst case)} */
#define DEFAULT_NTW_P_ACK_RX_TO 2500 // 250ms
/* Timeout for receiving a bACK {@2400bps PLM speed (worst case)} */
#define DEFAULT_NTW_P_bACK_RX_TO 2500 // 250ms:
/* Timeout for frame receptions (receiver) */
#define DEFAULT_NTW_P_FRM_RX_TO 0 // (100us step)
/* Minimum delay before any transmission */
#define DEFAULT_NTW_P_NDX_TO 100 // 10ms
/* Max attempts if no activity is detected */
#define DEFAULT_LL_MAX_ATTEMPT 5
/* Max repetition attempts (for processed ID, 0 = disabled) */

```

```
#define DEFAULT_MAX_RPT_ATTEMPT 0
```

2.2.1 Stack initialization

The following are the steps needed to configure the stack in the user application. First, all the parameters defined in the `interfaceconfig.h` file must be loaded in the stack configuration structures using the `LL_WM_t` and `LL_settings_t` data structure (defined in the file `stk_1.h`). For this issue, two initialization functions can be defined in the user application file.

```
LL_settings_t APP_InitStackDefaults(void)
{
    LL_settings_t ds; // Typedef defined in the stk_1.h file

    // Link Layer stack default settings
    ds.MIN_SLOT = DEFAULT_MIN_SLOT;
    ds.MAX_SLOT = DEFAULT_MAX_SLOT;
    ds.GLOBAL_TX_TO = DEFAULT_NTW_P_GLOBAL_TX_TO;
    ds.BC_GLOBAL_TX_TO = DEFAULT_NTW_P_BC_GLOBAL_TX_TO;
    ds.ACTIVITY_TO = DEFAULT_NTW_P_ACTIVITY_TO;
    ds.WATCHDOG_TO = DEFAULT_NTW_P_WATCHDOG_TO;
    ds.DATATRANSFER_TO = DEFAULT_NTW_P_DATATRANSFER_TO;
    ds.BANDINUSE_TO = DEFAULT_NTW_P_BANDINUSE_TO;
    ds.FRAME_TX_TO = DEFAULT_NTW_P_FRAME_TX_TO;
    ds.BCAST_TX_TO = DEFAULT_NTW_P_BCAST_TX_TO;
    ds.ACK_RX_TO = DEFAULT_NTW_P_ACK_RX_TO;
    ds.bACK_RX_TO = DEFAULT_NTW_P_bACK_RX_TO;
    ds.FRM_RX_TO = DEFAULT_NTW_P_FRM_RX_TO;
    ds.NDX_TO = DEFAULT_NTW_P_NDX_TO;
    ds.MAX_ATTEMPT = DEFAULT_LL_MAX_ATTEMPT;
    ds.MAX_RPT_ATTEMPT = DEFAULT_MAX_RPT_ATTEMPT;
    ds.TIME_SYNC = DEFAULT_DEVICE_TIME_SYNC;

    return ds;
}

LL_WM_t APP_InitStackWorkingMode(void)
{
    LL_WM_t wm; // Typedef defined in the stk_1.h file

    wm.DEVICE_OPT_ACK = LL_FRM_PARAM_DISABLED;
    wm.DEVICE_OPT_bACK = LL_FRM_PARAM_DISABLED;
    wm.DEVICE_OPT_RPT = LL_FRM_PARAM_DISABLED;
    wm.DEVICE_OPT_RPTALL = LL_FRM_PARAM_DISABLED;
    wm.DEVICE_OPT_GRP = LL_FRM_PARAM_DISABLED;
    wm.DEVICE_OPT_ENC = LL_FRM_PARAM_DISABLED;
    /* ACK frames */
}
```



```

#ifdef DEVICE_WM_REQ_ACK
    wm.DEVICE_OPT_ACK = LL_FRM_PARAM_ACK_REQ;
#endif
/* bACK frames */
#ifdef DEVICE_WM_REQ_BACK
    wm.DEVICE_OPT_BACK = LL_FRM_PARAM_BACK_REQ;
#endif
/* Repetitions */
#ifdef DEVICE_WM_REPEAT
    wm.DEVICE_OPT_RPT = LL_FRM_PARAM_REPEAT;
#endif
#ifdef DEVICE_WM_REPEAT_ALL
    wm.DEVICE_OPT_RPTALL = LL_FRM_PARAM_REPEAT_ALL;
#endif
/* Grouping */
#ifdef DEVICE_WM_GROUP_FILTER
    wm.DEVICE_OPT_GRP = LL_FRM_PARAM_GROUP;
#endif
/* Encryption */
#ifdef DEVICE_WM_ENCRYPT_DATA
    wm.DEVICE_OPT_ENC = LL_FRM_PARAM_ENCRYPTION;
#endif

return wm;
}

```

Once the initialization structures are loaded, the stack is configured with the following code:

```

if (NL_NetworkInit(APP_InitStackWorkingMode(), APP_InitStackDefaults()))
{
    uint16_t LocalGroup;
    uint32_t LocalAddress;
    /* Set the current group and address */
    NL_SetLocalAddress(LocalGroup, LocalAddress);
}

```

The `NL_SetLocalAddress` API sets the grouping and the address for the device. If the grouping is not used, the address is made up of both parameters, allowing a 6-byte addressing (2 for group and 4 for address).

At runtime (normally at the power-on if, for example, some or all the parameters are stored in the internal Flash memory of the STM32F103xx), it is possible to override some of the parameters set up with the previous function, using the following APIs:

```

/* Set the local working mode */
void NL_SetLocalWorkingMode(uint8_t WorkingMode);

```

where the meaning of each bit of the `WorkingMode` byte is explained in [Figure 7](#).

Figure 7. Stack working mode bitmap definition

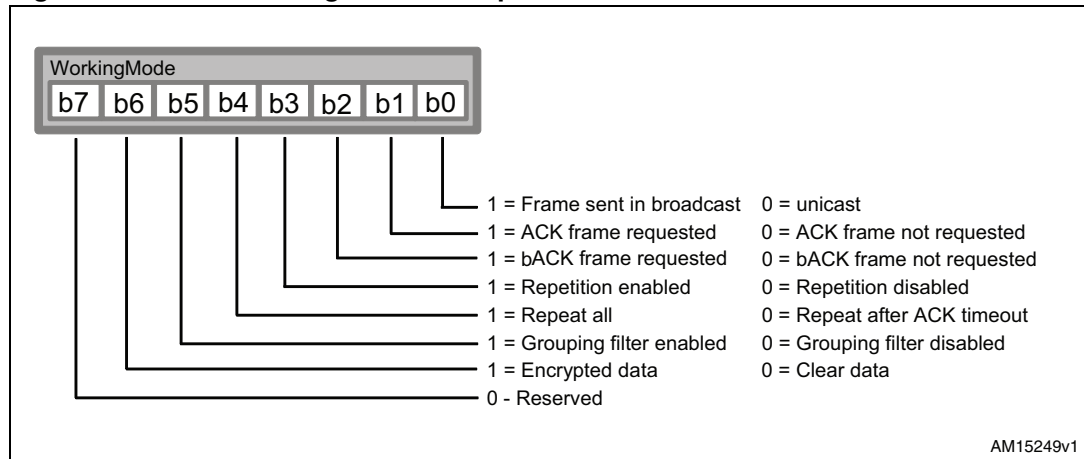

```

/* Set the local hop level */
void NL_SetLocalHopLevel(uint8_t HopLevel);
/* Set the stack parameters (typedef defined in stk_n.h file) */
void NL_SetDataLinkStackParameters(NL_DLSP_t devparam);
    
```

2.2.2 Stack data reception service (NL_NetworkIndication)

The service used for receiving data from the network is defined in the `stk_n.h` file, which is the interface between the ST7540 stack and the user application level.

```
NL_Status_t nNStatus = NL_NetworkIndication(NL_Data_t *ntw_data, uint32_t timeout);
```

The value returned in the `nNStatus` variable can be one of the values defined in the `NL_Status_t` structure, defined in the file `stk_n.h`.

```

if (nNStatus.operation == N_DOING)
{
    /* PL: IDLE MODE */

    /* User application while no data is arrived from PLM */
    ...
}

else if (nNStatus.operation == N_ERROR)
{
    /* PL: DATA RECEPTION ERROR */

    /* Error Management */
    ...
}

else if (nNStatus.operation == N_SUCCESS)
{
    /* PL: DATA ARRIVED */
    
```

```

    /* Valid data arrived from PLM and addressed to this device or
    sent in broadcast by a remote PLM. (broadcast frame are sent with
    LL_BROADCAST_FLAG set in the ntw_data.frame_type field) */
}

```

When valid data arrive from the power line, data can be recovered from the structure `NL_Data_t` (in this example, pointed by `*ntw_data` pointer).

```

typedef struct
{
    uint16_t  group; // Sender group
    uint32_t  address; // Sender address
    uint8_t   framelen; // Arrived frame length
    NL_Type_t frametype; // Arrived frame type
    uint8_t   databuffer[PAYLOAD_SIZE]; // Arrived user data
}NL_Data_t;

```

The group field is the same as this device if the grouping option is enabled, because, by enabling the group filter, all the frames coming from a different group are ignored (even those sent in broadcast).

When the variable `nNStatus.operation` value is `N_SUCCESS`, the data are valid, meaning with a correct preamble, a correct CRC (CRC16 is automatically inserted by the stack during the transmission and checked, and then removed during the reception), with one of the admitted frame types, addressed to this device (or sent in broadcast) belonging to this group and correctly acknowledged by the sender. All of this is transparent to the user as it is automatically managed by the stack.

The fields data buffer and framelen contain the user raw data and the data length. Refer to the `stk_n.h` file for the admitted frame types.

If a data reception error occurs, this can be verified checking the value of the field error of the `NL_Status_t` structure (`nNStatus.error`).

The following enumerations are the possible communication errors (including also the transmission errors) and are reported in the `stk_n.h` file.

```

typedef enum
{
    NL_ERR_NONE, // No error
    NL_ERR_NOT_READY, // Stack not initialized
    NL_ERR_NETWORK_TIMEOUT, // Given timeout elapsed
    NL_ERR_TRANSMISSION_ERROR, // Data transmission error
    NL_ERR_COMMUNICATION_TIMEOUT, // Communication timeout
    NL_ERR_LINE_ERROR, // Power line error
    NL_ERR_TARGET_NOT_REACHABLE, // Target device unreachable
    NL_ERR_FRAME_CLASS_UNKNOWN, // Unknown frame type
    NL_ERR_GENERIC // Unclassified error
}

```

```
}NL_ERR_t;
```

2.2.3 Stack data transmission service (NL_NetworkRequest)

The service used for transmitting data from the network is also defined in the `stk_n.h` file:

```
NL_Status_t nNStatus = NL_NetworkRequest(NL_Data_t *ntw_data, uint32_t timeout);
```

In order to transmit user data, first the `NL_Data_t` structure must be filled.

```
NL_Data_t user_data;
uint8_t i;

user_data.group = TargetDeviceGroup; // Or use as address
user_data.address = TargetDeviceAddress;
user_data.frameLen = PAYLOAD_SIZE;
user_data.frameType = NL_CLS_DATA_FRAME; // Data frame is selected
/* Load user data to transmit */
for (i = 0; i < PAYLOAD_SIZE; i++)
    user_data.databuffer[i] = UserData[i];
```

If the frame must be sent in broadcast, the fields `user_data.group` and `user_data.address` can be set to 0 (they are ignored by the other devices) and the broadcast flag must be added to the frame type:

```
user_data.frameType |= LL_BROADCAST_FLAG; // Send data in broadcast
```

The returned values are the same as for the data reception service, where the `N_SUCCESS` value indicates the correct data transfer with the assurance of data packet delivery. The resulting cases are the same as those of the indication service.

```
if (nNStatus.operation == N_DOING)
{
    /* PL: IDLE MODE */

    /* User application while data is being transmitting via PLM */
    ...
}

else if (nNStatus.operation == N_ERROR)
{
    /* PL: DATA TRANSMISSION ERROR */

    /* Error Management */
    ...
}

else if (nNStatus.operation == N_SUCCESS)
{
    /* PL: DATA TRANSMITTED */
```

```

    /* Data delivery to the target device successfull */
    ...
}

```

2.2.4 Other stack interface APIs

In the network interface file (`stk_n.h`) there are some other APIs that can be used in the user application.

The first of which is a function used to reset the state machines and restart the engines:

```
void NL_NetworkRestart(void);
```

In order to know or to set the current stack settings and working mode, the following APIs are available:

```

/* Working mode (DNL_DLSP_t defined in stk_n.h file) */
void NL_GetDataLinkStackParameters(NL_DLSP_t *llsp);
void NL_SetDataLinkStackParameters(NL_DLSP_t llsp);

/* Get API's */
uint8_t NL_GetLocalWorkingMode(void);
uint8_t NL_GetLocalHopLevel(void);
void NL_GetLocalAddress(uint16_t *nDevGrp, uint32_t *nDevAdd);

/* Set API's */
void NL_SetLocalAddress(uint16_t nDevGrp, uint32_t nDevAdd);
void NL_SetLocalWorkingMode(uint8_t wmode);
void NL_SetLocalHopLevel(uint8_t hlevel);

```

To set up the working mode, it is possible to set the single flag, without changing the value of the other flags.

```
void NL_SetLocalWorkingModeFlag(NL_WMFlag_t flag, NL_WMFlag_status_t sts);
```

The following is a list of the flags and the values those flags can assume.

```

typedef enum
{
    F_BROADCAST = 0x01,
    F_ACK       = 0x02,
    F_bACK      = 0x04,
    F_REPEATER  = 0x08,
    F_GROUP     = 0x10
}NL_WMFlag_t;

typedef enum

```

```
{
    F_ENABLED,
    F_DISABLED
}NL_WMFlag_status_t;
```

If the AES128 encryption is enabled, the function to use to set up the AES key is:

```
void NL_SetEncryptionKey(uint8_T *Ekey);
```

Once the encryption is enabled by selecting the `DEVICE_WM_ENCRYPT_DATA` option in the `interfaceconfig.h` file, data is encrypted using the AES128 algorithm with the supplied AES key (`Ekey`), and if the target device has the encryption enabled too and also has the same key, the data is correctly decoded directly by the stack. If the encryption is not enabled or the key is different, the data frame is discharged and consequently not acknowledged.

Finally, it is possible to know the stack firmware release (two bytes, in the x.y decimal format) calling the API:

```
/* Stack firmware release (x).(y) */
uint16_t NL_GetStackFirmwareRelease(void);
```

3 Stack firmware structure

The stack firmware structure contained inside the zip file supplied with this user manual is shown in [Figure 8](#).

Inside the root there is the `interfaceconfig.h` file which contains all the macros used for the stack configuration and option setup.

The `src` directory contains all the source files and the object files (the object files refer to the `AES128.o`, `stk_l.o` and `stk_n.o` files). The `stk_p.c` and the ST7540 driver contain the source code allowing the user to make modifications eventually required by the chosen microcontroller.

Figure 8. Stack firmware structure

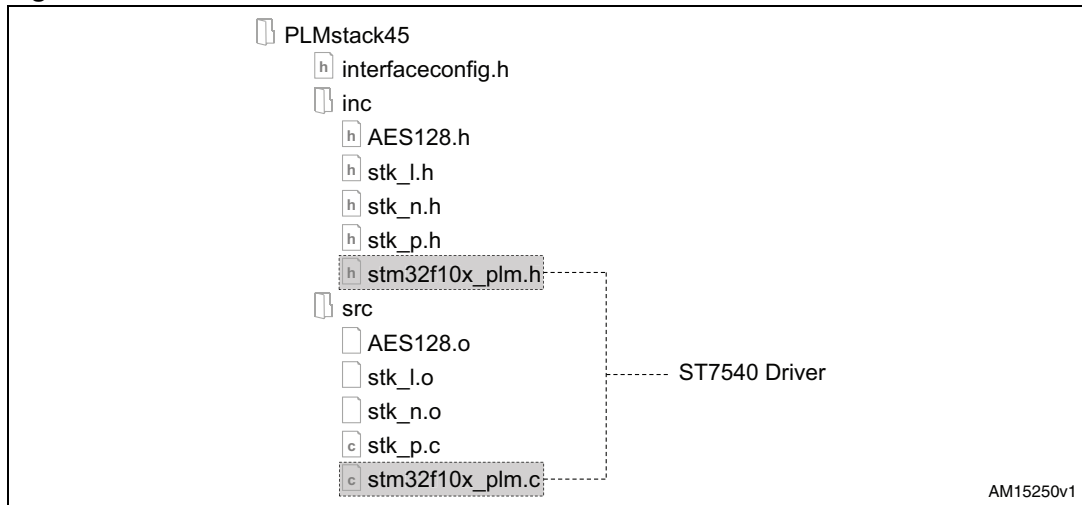

The `inc` directory contains all the definition files to include in the user project.

[Table 1](#) shows the stack firmware weight in terms of memory (both Flash and RAM).

The stack firmware uses some microcontroller peripheral libraries which must be considered to calculate the final code size. The used STM32F103xx microcontroller libraries are listed below:

- `stm32f10x_gpio`
- `stm32f10x_exti`
- `stm32f10x_spi`
- `stm32f10x_rtc`
- `stm32f10x_bkp`
- `stm32f10x_iwdg`
- `stm32f10x_rcc`
- `stm32f10x_tim`
- `<time.h>`

Table 1. Stack firmware module data size

IAR ELF Linker V6.30.1.53127/W32 for ARM Copyright 2007-2011 IAR systems AB			
Module	ro code	ro data	rw data
AES128.o	2 402	2 060	152
stk_l.o	6 796	515	629
stk_n.o	1 106		
stk_p.o	1 144		18
stm32f10x_plm.o	2 364	322	712
Total bytes	13 812	2 897	1 511

where:

- ro code = bytes of read only code memory
- ro data = bytes of read only data memory
- rw data = bytes of read/write data memory.

4 References

1. ARM-based 32-bit MCU STM32F10x Standard Peripheral Library Rel 3.5.0 (2011).
2. ST7540 FSK power line transceiver datasheets (2006).
3. AN3046 application note.
4. IAR embedded workbench IDE Rel. 6.3 documentation (www.iar.com).

5 Revision history

Table 2. Document revision history

Date	Revision	Changes
12-Nov-2012	1	Initial release.

Please Read Carefully:

Information in this document is provided solely in connection with ST products. STMicroelectronics NV and its subsidiaries ("ST") reserve the right to make changes, corrections, modifications or improvements, to this document, and the products and services described herein at any time, without notice.

All ST products are sold pursuant to ST's terms and conditions of sale.

Purchasers are solely responsible for the choice, selection and use of the ST products and services described herein, and ST assumes no liability whatsoever relating to the choice, selection or use of the ST products and services described herein.

No license, express or implied, by estoppel or otherwise, to any intellectual property rights is granted under this document. If any part of this document refers to any third party products or services it shall not be deemed a license grant by ST for the use of such third party products or services, or any intellectual property contained therein or considered as a warranty covering the use in any manner whatsoever of such third party products or services or any intellectual property contained therein.

UNLESS OTHERWISE SET FORTH IN ST'S TERMS AND CONDITIONS OF SALE ST DISCLAIMS ANY EXPRESS OR IMPLIED WARRANTY WITH RESPECT TO THE USE AND/OR SALE OF ST PRODUCTS INCLUDING WITHOUT LIMITATION IMPLIED WARRANTIES OF MERCHANTABILITY, FITNESS FOR A PARTICULAR PURPOSE (AND THEIR EQUIVALENTS UNDER THE LAWS OF ANY JURISDICTION), OR INFRINGEMENT OF ANY PATENT, COPYRIGHT OR OTHER INTELLECTUAL PROPERTY RIGHT.

UNLESS EXPRESSLY APPROVED IN WRITING BY TWO AUTHORIZED ST REPRESENTATIVES, ST PRODUCTS ARE NOT RECOMMENDED, AUTHORIZED OR WARRANTED FOR USE IN MILITARY, AIR CRAFT, SPACE, LIFE SAVING, OR LIFE SUSTAINING APPLICATIONS, NOR IN PRODUCTS OR SYSTEMS WHERE FAILURE OR MALFUNCTION MAY RESULT IN PERSONAL INJURY, DEATH, OR SEVERE PROPERTY OR ENVIRONMENTAL DAMAGE. ST PRODUCTS WHICH ARE NOT SPECIFIED AS "AUTOMOTIVE GRADE" MAY ONLY BE USED IN AUTOMOTIVE APPLICATIONS AT USER'S OWN RISK.

Resale of ST products with provisions different from the statements and/or technical features set forth in this document shall immediately void any warranty granted by ST for the ST product or service described herein and shall not create or extend in any manner whatsoever, any liability of ST.

ST and the ST logo are trademarks or registered trademarks of ST in various countries.

Information in this document supersedes and replaces all information previously supplied.

The ST logo is a registered trademark of STMicroelectronics. All other names are the property of their respective owners.

© 2012 STMicroelectronics - All rights reserved

STMicroelectronics group of companies

Australia - Belgium - Brazil - Canada - China - Czech Republic - Finland - France - Germany - Hong Kong - India - Israel - Italy - Japan - Malaysia - Malta - Morocco - Philippines - Singapore - Spain - Sweden - Switzerland - United Kingdom - United States of America

www.st.com