

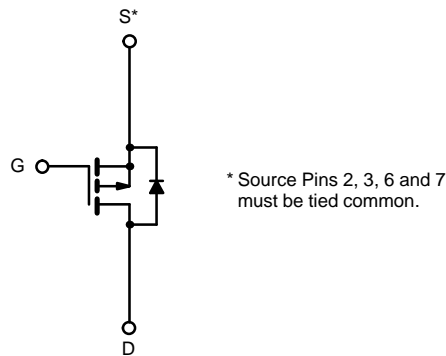

P-Channel 30-V (D-S) MOSFET

PRODUCT SUMMARY		
V_{DS} (V)	$r_{DS(on)}$ (Ω)	I_D (A)
-30	0.030 @ $V_{GS} = -10$ V	± 5.5
	0.055 @ $V_{GS} = -4.5$ V	± 4.1

TrenchFET[®]
Power MOSFETS

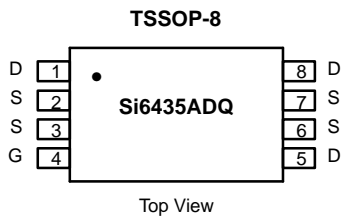

P-Channel MOSFET

ABSOLUTE MAXIMUM RATINGS ($T_A = 25^\circ\text{C}$ UNLESS OTHERWISE NOTED)				
Parameter	Symbol	10 secs	Steady State	Unit
Drain-Source Voltage	V_{DS}	-30		V
Gate-Source Voltage	V_{GS}	± 20		
Continuous Drain Current ($T_J = 150^\circ\text{C}$) ^a	I_D	$T_A = 25^\circ\text{C}$	± 5.5	A
		$T_A = 70^\circ\text{C}$	± 4.5	
Pulsed Drain Current (10 μs Pulse Width)	I_{DM}	± 30		
Continuous Source Current (Diode Conduction) ^a	I_S	-1.35	-0.95	
Maximum Power Dissipation ^a	P_D	$T_A = 25^\circ\text{C}$	1.5	W
		$T_A = 70^\circ\text{C}$	1.0	
Operating Junction and Storage Temperature Range	T_J, T_{stg}	-55 to 150		$^\circ\text{C}$

THERMAL RESISTANCE RATINGS				
Parameter	Symbol	Typical	Maximum	Unit
Maximum Junction-to-Ambient ^a	R_{thJA}	$t \leq 10$ sec	65	$^\circ\text{C/W}$
		Steady State	100	
Maximum Junction-to-Foot	R_{thJF}	43	52	

Notes

a. Surface Mounted on 1" x 1" FR4 Board.

SPECIFICATIONS (T_J = 25 °C UNLESS OTHERWISE NOTED)

Parameter	Symbol	Test Condition	Min	Typ	Max	Unit
Static						
Gate Threshold Voltage	V _{GS(th)}	V _{DS} = V _{GS} , I _D = -250 μA	-1.0			V
Gate-Body Leakage	I _{GSS}	V _{DS} = 0 V, V _{GS} = ±20 V			±100	nA
Zero Gate Voltage Drain Current	I _{DSS}	V _{DS} = -24 V, V _{GS} = 0 V			-1	μA
		V _{DS} = -24 V, V _{GS} = 0 V, T _J = 70 °C			-10	
On-State Drain Current ^a	I _{D(on)}	V _{DS} = -5 V, V _{GS} = -10 V	-30			A
		V _{DS} = -5 V, V _{GS} = -4.5 V	-7			
Drain-Source On-State Resistance ^a	r _{DS(on)}	V _{GS} = -10 V, I _D = -5.5 A		0.024	0.030	Ω
		V _{GS} = -4.5 V, I _D = -4.1 A		0.042	0.055	
Forward Transconductance ^a	g _{fs}	V _{DS} = -15 V, I _D = -5.5 A		12		S
Diode Forward Voltage ^a	V _{SD}	I _S = -1.3 A, V _{GS} = 0 V		-0.8	-1.1	V
Dynamic^b						
Total Gate Charge	Q _g	V _{DS} = -15 V, V _{GS} = -5 V, I _D = -5.5 A		15	20	nC
Gate-Source Charge	Q _{gs}			5.7		
Gate-Drain Charge	Q _{gd}			5.0		
Turn-On Delay Time	t _{d(on)}	V _{DD} = -15 V, R _L = 15 Ω I _D ≅ -1 A, V _{GEN} = -10 V, R _G = 6 Ω		12	20	ns
Rise Time	t _r			10	20	
Turn-Off Delay Time	t _{d(off)}			42	60	
Fall Time	t _f			17	25	
Source-Drain Reverse Recovery Time	t _{rr}	I _F = -1.3 A, di/dt = 100 A/μs		40	80	

Notes

- a. Pulse test; pulse width ≤ 300 μs, duty cycle ≤ 2%.
 b. Guaranteed by design, not subject to production testing.

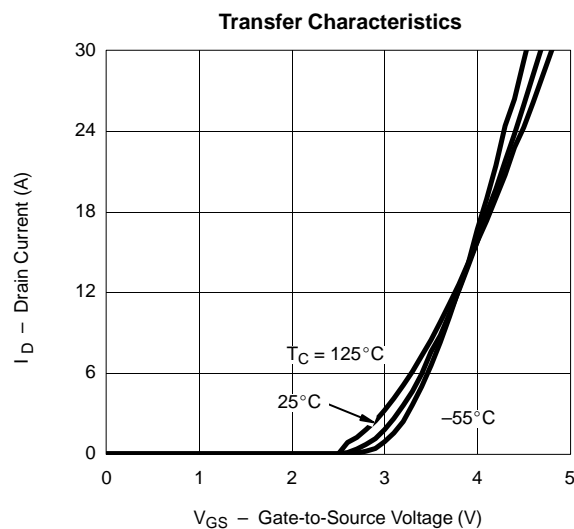
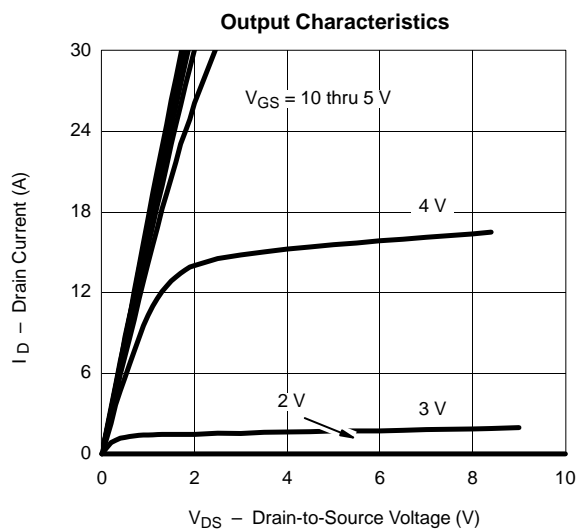
TYPICAL CHARACTERISTICS (25 °C UNLESS NOTED)



TYPICAL CHARACTERISTICS (25°C UNLESS NOTED)

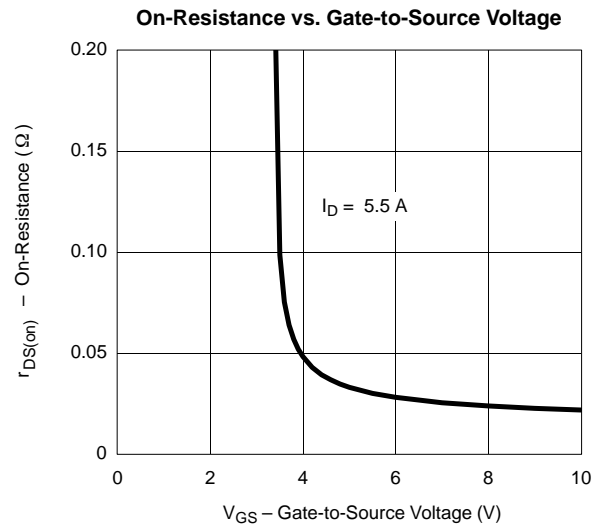
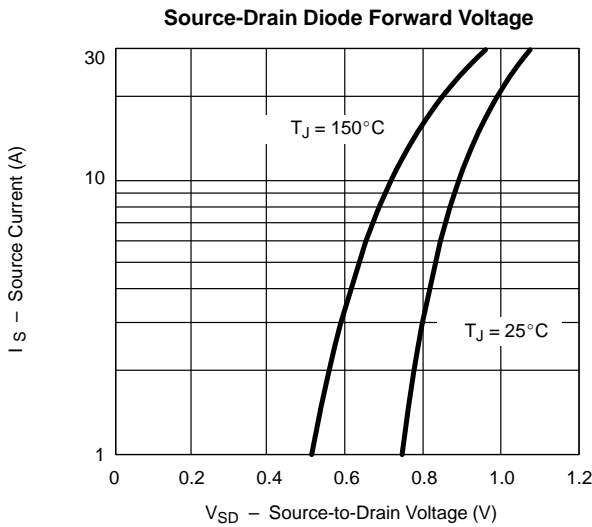
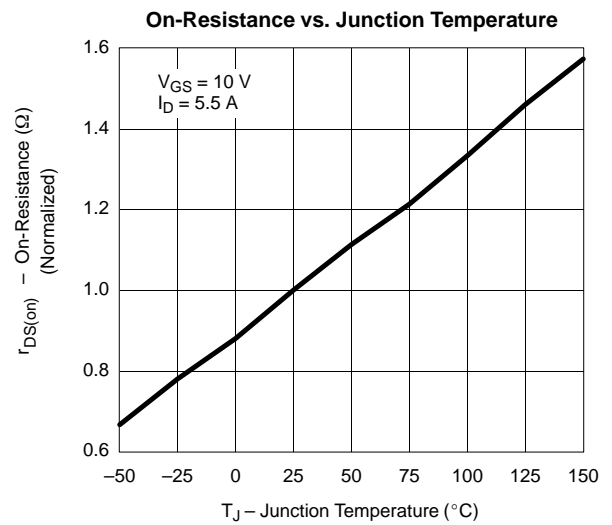
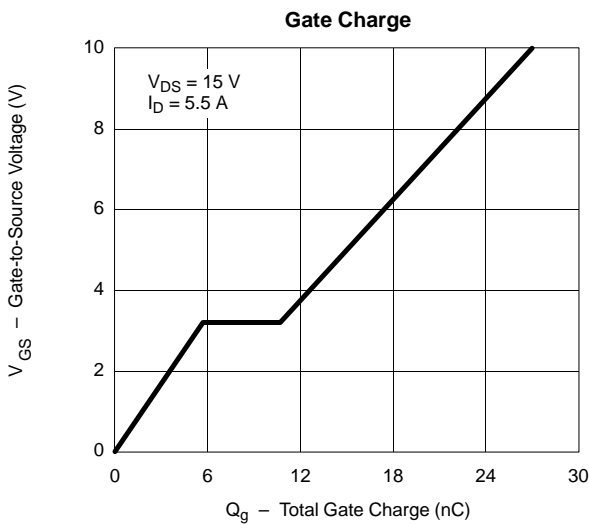
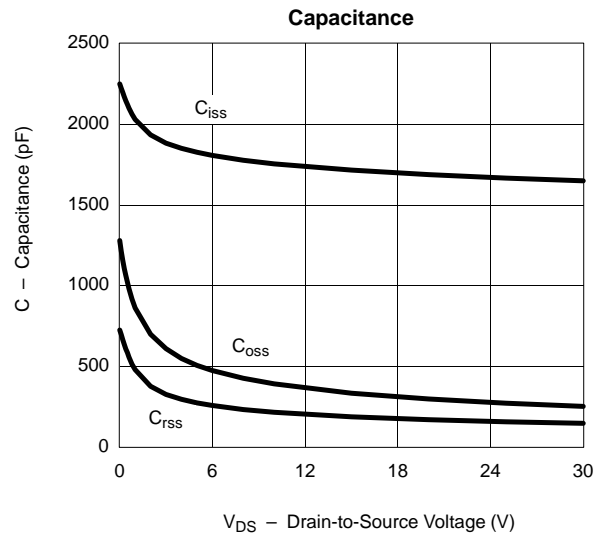
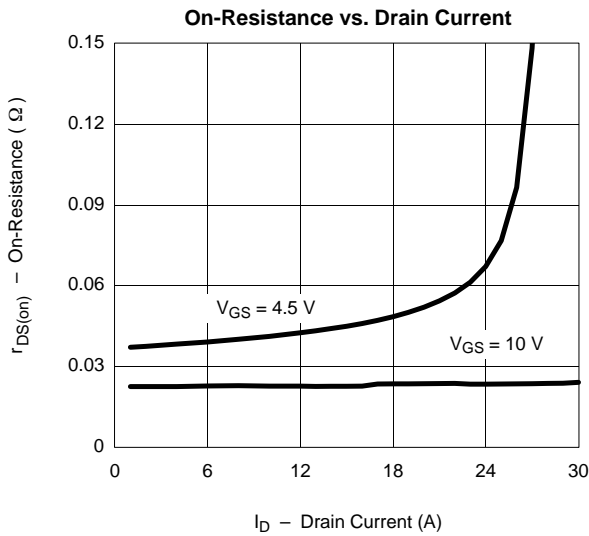



TYPICAL CHARACTERISTICS (25 °C UNLESS NOTED)

