

Features

- High current density per square mm

Applications

- Overvoltage crowbar protection
- Motor control circuits in power tools and kitchen aids
- Inrush current limiting circuits

Description

This device is mounted in DPAK and intended for use in applications such as voltage regulators circuits for motorbikes, overvoltage crowbar protection, motor control circuits in power tools and capacitive discharge ignition.

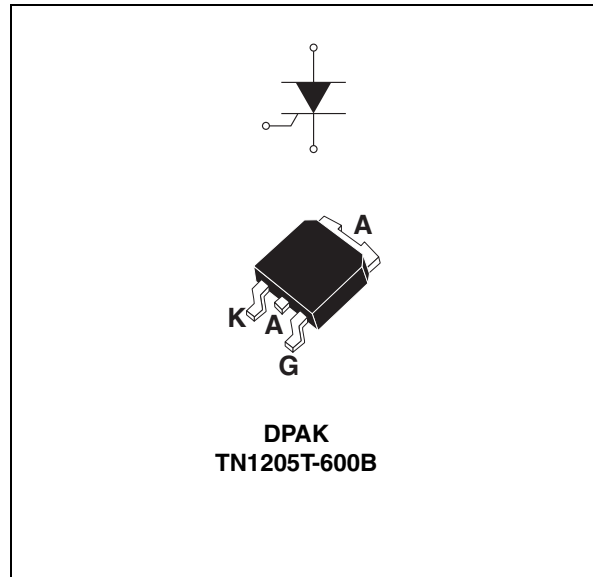

Table 1. Device summary

$I_{T(rms)}$	12 A
V_{DRM}/V_{RRM}	600 V
I_{GT}	2 to 5 mA

1 Characteristics

Table 2. Absolute ratings⁽¹⁾

Symbol	Parameter		Value	Unit	
$I_{T(RMS)}$	On-state rms current (180 °C conduction angle)		$T_c = 103\text{ °C}$	12	A
$I_{T(AV)}$	Average on-state current(180 °C conduction angle)		$T_c = 103\text{ °C}$	8	A
I_{TSM}	Non repetitive surge peak on-state current		$t_p = 8.3\text{ ms}$ $t_p = 10\text{ ms}$	120 115	A
I^2T	I^2T value for fusing		$t_p = 10\text{ ms}$	66	A ² s
di/dt	Critical rate of rise of on-state current $I_G = 2 \times I_{GT}$, $tr \leq 100\text{ ns}$	F = 60 Hz	$T_j = 125\text{ °C}$	50	A/μs
I_{GM}	Peak gate current	$t_p = 20\text{ μs}$	$T_c = 125\text{ °C}$	4	A
$P_{G(AV)}$	Average gate power dissipation		$T_j = 125\text{ °C}$	1	W
T_{stg}	Storage junction temperature range			-40 to + 150	°C
T_j	Operating junction temperature range			-40 to + 125	

1. $T_j = 25\text{ °C}$, unless otherwise specified

Table 3. Electrical characteristics⁽¹⁾

Symbol	Test conditions		Min.	Typ.	Max.	Unit
I_{GT}	$V_D = 12\text{ V}$, $R_L = 33\text{ Ω}$		2		5	mA
V_{GT}	$V_D = 12\text{ V}$, $R_L = 33\text{ Ω}$				1.3	V
V_{GD}	$V_D = V_{DRM}$, $R_L = 3.3\text{ kΩ}$	$T_j = 125\text{ °C}$	0.2			V
I_H	$I_T = 500\text{ mA}$ gate open				15	mA
I_L	$I_G = 1.2 I_{GT}$				30	mA
dV/dt	$V_D = 67\% V_{DRM}$ gate open	$T_j = 125\text{ °C}$	100			V/μs
t_{GT}	Gate controlled turn on time $I_{TM} = 40\text{ A}$, $V_D = V_{DRM(MAX)}$, $I_{GT} = 100\text{ mA}$ $dl_G/dt = 5\text{ A/μs}$, $R_G = 68\text{ Ω}$			1.2		μs
t_q	Circuit commutated turn off time $V_D = 67\% V_{DRM(MAX)}$, $T_j = 125\text{ °C}$, $I_{TM} = 20\text{ A}$, $V_R = 25\text{ V}$ $dl_T/dt = 30\text{ A/μS}$, $dV_D/dt = 50\text{ V/μs}$, $R_{GK} = 100\text{ Ω}$			55		μs
V_{TM}	$I_{TM} = 24\text{ A}$, $T_p = 380\text{ μs}$				1.6	V
V_{T0}	Threshold voltage	$T_j = 125\text{ °C}$			0.85	V
R_d	Dynamyc restistance	$T_j = 125\text{ °C}$			30	mΩ
I_{DRM} I_{RRM}	$V_{DRM} = V_{RRM}$	$T_j = 25\text{ °C}$			5	μA
		$T_j = 125\text{ °C}$			2	mA

1. $T_j = 25\text{ °C}$, unless otherwise specified

Table 4. Thermal resistance

Symbol	Parameter	Value	Unit
$R_{th(j-c)}$	Junction to case (DC)	1.8	$^{\circ}C/W$
$R_{th(j-a)}$	Junction to ambient (DC)	$S^{(1)} = 0.5 \text{ cm}^2$ 70	$^{\circ}C/W$

1. S = Copper surface under tab.

Figure 1. Maximum average power dissipation versus average on-state current

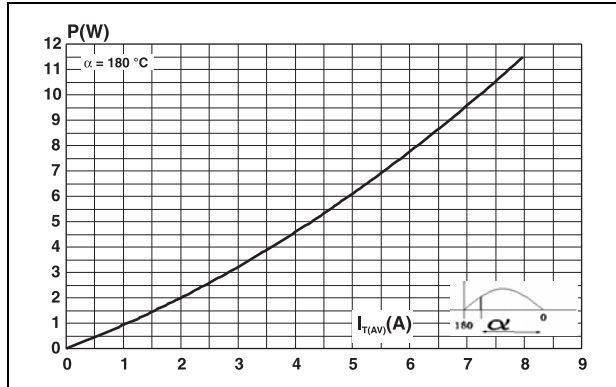

Figure 2. Average and DC on-state current versus case temperature

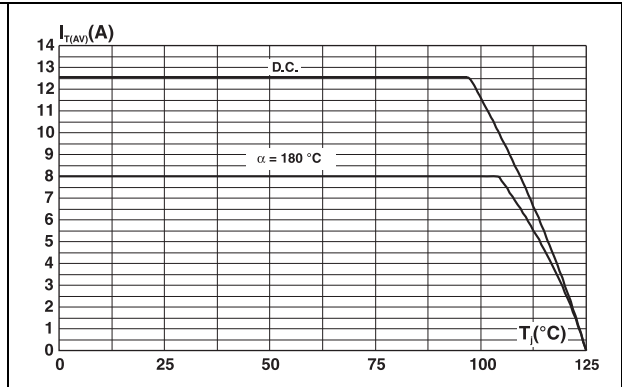

Figure 3. Average DC on-state current versus ambient temperature

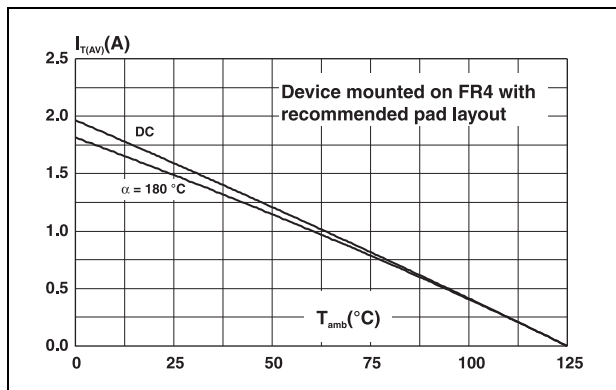

Figure 4. Relative variation of thermal impedance junction to case versus pulse duration

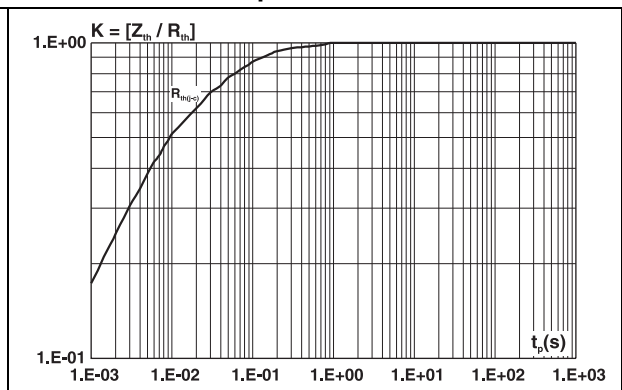

Figure 5. Relative variation of thermal impedance junction to ambient versus pulse duration

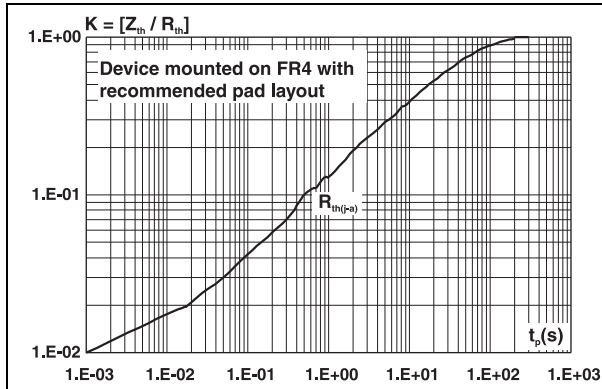

Figure 6. Relative variation of gate trigger current and voltage, holding and latching current versus Tj

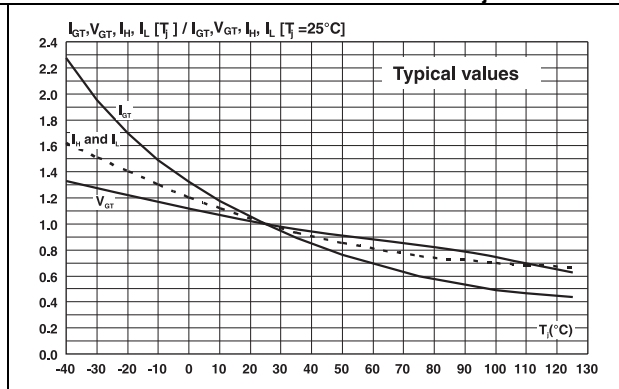

Figure 7. Surge peak on-state current versus number of cycles

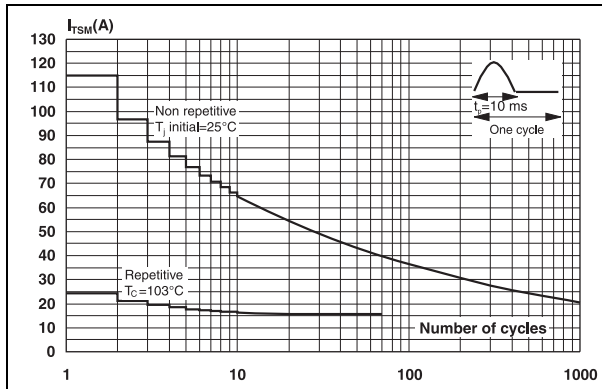

Figure 8. Non-repetitive surge peak on-state current for a sinusoidal pulse, and corresponding values of I²t

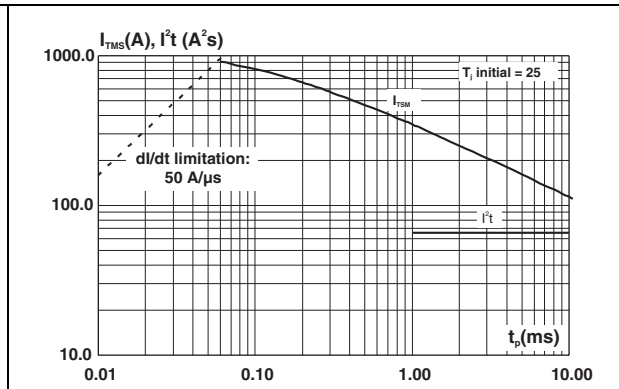

Figure 9. On-state characteristics (maximum values)

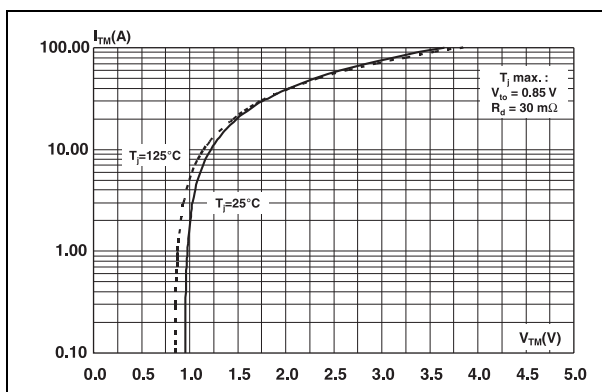
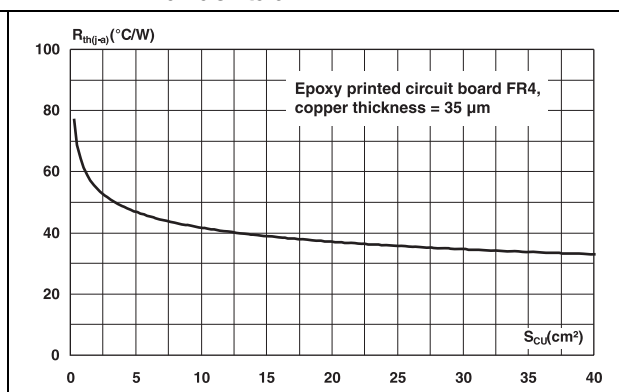
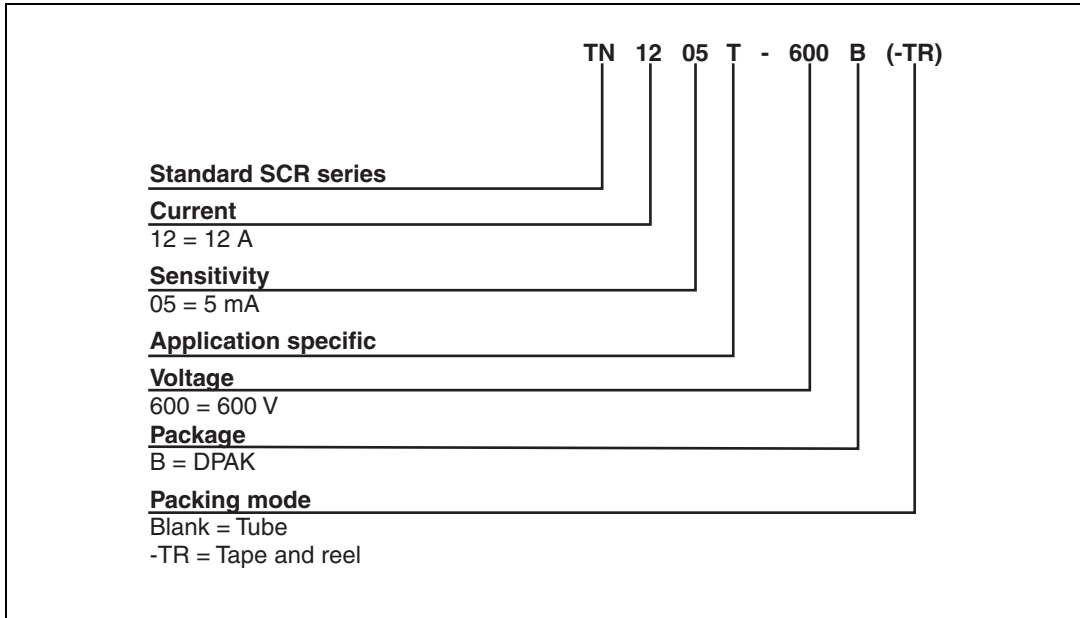

Figure 10. Thermal resistance junction to ambient versus copper surface under tab



2 Ordering information scheme

Figure 11. Ordering information scheme



3 Package information

- Epoxy meets UL94, V0
- Lead-free package

Table 5. DPAK dimensions

Ref.	Dimensions			
	Millimeters		Inches	
	Min.	Max.	Min.	Max.
A	2.20	2.40	0.086	0.094
A1	0.90	1.10	0.035	0.043
A2	0.03	0.23	0.001	0.009
B	0.64	0.90	0.025	0.035
B2	5.20	5.40	0.204	0.212
C	0.45	0.60	0.017	0.023
C2	0.48	0.60	0.018	0.023
D	6.00	6.20	0.236	0.244
E	6.40	6.60	0.251	0.259
G	4.40	4.60	0.173	0.181
H	9.35	10.10	0.368	0.397
L2	0.80 typ.		0.031 typ.	
L4	0.60	1.00	0.023	0.039
V2	0°	8°	0°	8°

Figure 12. Footprint (dimensions in mm)

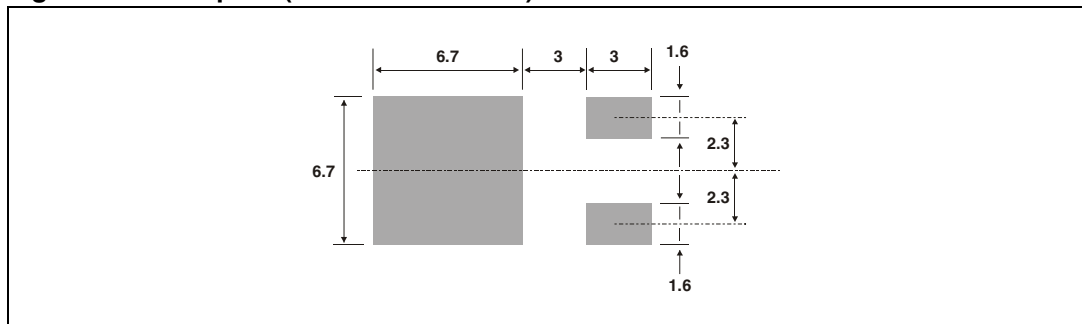

4 Ordering information

Table 6. Ordering information

Order code	Marking	Package	Weight	Base qty	Delivery mode
TN1205T-600B	TN12 05T6	DPAK	0.3g	75	Tube
TN1205T-600B-TR	TN12 05T6			2500	Tape and reel

5 Revision history

Table 7. Document revision history

Date	Revision	Changes
01-Oct-2009	1	Initial release.