



## FPDB60PH60B PFC SPM<sup>®</sup> 3 Series for 2-Phase Bridgeless PFC

### Features

- Low Thermal Resistance Thanks to AIN-DBC Substrate
- 600 V - 60 A 2-Phase Bridgeless PFC Including A Drive IC for Gate Driving and Protection
- Built-In NTC Thermistor for Monitoring Over-Temperature
- Built-In Shunt Resistor for Current Sensing
- Typical Switching Frequency of 20 kHz
- Isolation Rating of 2500 Vrms/min.

### Applications

- 2-Phase Bridgeless PFC Converter for Air Conditioner

### General Description

FPDB60PH60B Is An Advanced PFC SPM 3 Series for 2-Phase Bridgeless PFC (Power Factor Correction) that Fairchild Has Newly Developed for Mid-Power Applications such as Air Conditioners. It Combines Optimized Circuit Protection and Drive IC Matched To High Frequency Switching IGBTs. The System Reliability Is Further Enhanced by The Integrated Under-Voltage Lock-Out and Over-Current Protection Function.

### Related Source

- [AN-9041 - Bridgeless PFC SPM 3 Series Design Guide](#)

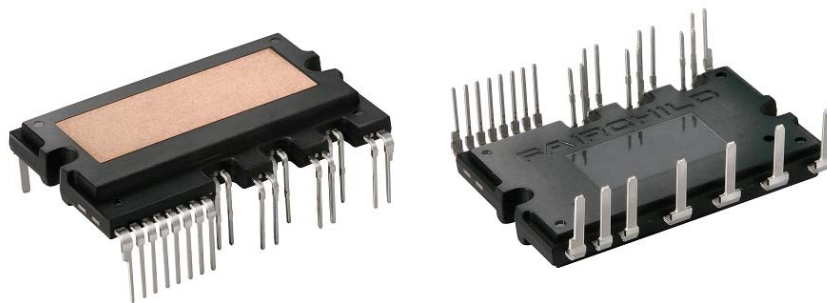

Fig. 1. Package Overview

### Package Marking & Ordering Information

Device Marking	Device	Package	Packing Type	Reel Size	Tape Width	Quantity
FPDB60PH60B	FPDB60PH60B	SPMHC-027	RAIL	-	-	10

### Integrated Power Functions

- PFC converter for single-phase AC/DC power conversion (Please refer to Fig. 3)

### Integrated Drive, Protection and System Control Functions

- For IGBTs : Gate drive circuit, Over Current(OC) protection, Control supply circuit Under-Voltage(UV) protection
- Fault signal : Corresponding to OC and UV fault
- Built-in thermistor: Over-temperature monitoring
- Input interface : Active-high interface, can work with 3.3 / 5 V Logic, Schmitt trigger input

### Pin Configuration

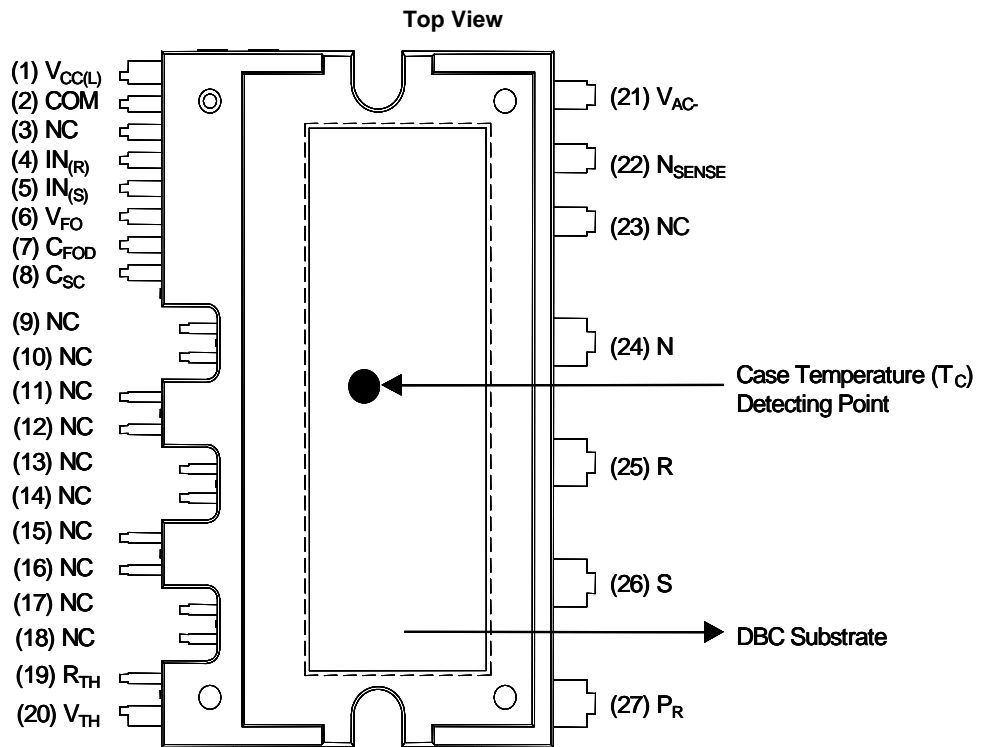
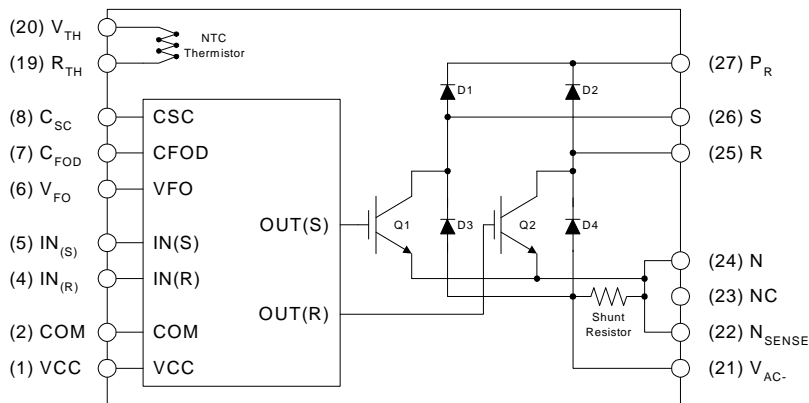

Fig. 2.

### Pin Descriptions

Pin Number	Pin Name	Pin Description
1	V <sub>CC</sub>	Common Bias Voltage for IC and IGBTs Driving
2	COM	Common Supply Ground
4	IN <sub>(R)</sub>	Signal Input for Low-side R-phase IGBT
5	IN <sub>(S)</sub>	Signal Input for Low-side S-phase IGBT
6	V <sub>FO</sub>	Fault Output
7	C <sub>FOD</sub>	Capacitor for Fault Output Duration Time Selection
8	C <sub>SC</sub>	Capacitor (Low-pass Filter) for Over Current Detection
19	R <sub>(TH)</sub>	NTC Thermistor terminal
20	V <sub>(TH)</sub>	NTC Thermistor terminal
21	V <sub>AC-</sub>	Current Sensing Terminal
22	N <sub>SENSE</sub>	Current Sensing Reference Terminal
24	N	Negative Rail of DC-Link
25	R	Output for R Phase
26	S	Output for S Phase
27	P <sub>R</sub>	Positive Rail of DC-Link
3, 9-18, 23	NC	No Connection

### Internal Equivalent Circuit and Input/Output Pins



**Note :**

1) Converter is composed of two IGBTs including four diodes and one IC which has gate driving and protection functions.

**Fig. 3.**

**Absolute Maximum Ratings** ( $T_J = 25^\circ\text{C}$ , Unless Otherwise Specified)**Converter Part**

Item	Symbol	Condition	Rating	Unit
Supply Voltage	$V_i$	Applied between R-S	264	$V_{RMS}$
Supply Voltage (Surge)	$V_{i(Surge)}$	Applied between R-S	500	V
Output Voltage	$V_{PN}$	Applied between P- N	450	V
Output Voltage (Surge)	$V_{PN(Surge)}$	Applied between P- N	500	V
Collector-emitter Voltage	$V_{CES}$		600	V
Each IGBT collector current	$\pm I_C$	$T_C = 25^\circ\text{C}$	60	A
Each IGBT collector current (Peak)	$\pm I_{CP}$	$T_C = 25^\circ\text{C}$ , Under 1 ms pulse width	90	A
Collector Dissipation	$P_C$	$T_C = 25^\circ\text{C}$ per One IGBT	178	W
Repetitive Peak Reverse Voltage	$V_{RRM}$		600	V
Peak Forward Surge Current	$I_{FSM}$	Single half sine-wave	350	A
Power Rating of Shunt Resistor	$P_{RSH}$	$T_C < 125^\circ\text{C}$	2	W
Operating Junction Temperature	$T_J$	(Note 1)	-40 ~ 150	$^\circ\text{C}$

**Note :**

1. The maximum junction temperature rating of the power chips integrated within the PFC SPM® product is  $150^\circ\text{C} (@T_C \leq 100^\circ\text{C})$ .

**Control Part**

Item	Symbol	Condition	Rating	Unit
Control Supply Voltage	$V_{CC}$	Applied between $V_{CC}$ - COM	20	V
Input Signal Voltage	$V_{IN}$	Applied between IN - COM	-0.3~17	V
Fault Output Supply Voltage	$V_{FO}$	Applied between $V_{FO}$ - COM	-0.3~ $V_{CC}+0.3$	V
Fault Output Current	$I_{FO}$	Sink Current at $V_{FO}$ Pin	5	mA
Current Sensing Input Voltage	$V_{SC}$	Applied between $C_{SC}$ - COM	-0.3~ $V_{CC}+0.3$	V

**Total System**

Item	Symbol	Condition	Rating	Unit
Module Case Operation Temperature	$T_C$		-20 ~ 100	$^\circ\text{C}$
Storage Temperature	$T_{STG}$		-40 ~ 150	$^\circ\text{C}$
Isolation Voltage	$V_{ISO}$	60 Hz, Sinusoidal, AC 1 minute, Connection Pins to DBC	2500	$V_{rms}$

**Thermal Resistance**

Item	Symbol	Condition	Min.	Typ.	Max.	Unit
Junction to Case Thermal Resistance (Referenced to PKG center)	$R_{\theta(j-c)Q}$	IGBT	-	-	0.7	$^\circ\text{C/W}$
	$R_{\theta(j-c)HD}$	High-side diode	-	-	1.5	$^\circ\text{C/W}$
	$R_{\theta(j-c)LD}$	Low-side diode	-	-	0.85	$^\circ\text{C/W}$

**Note :**

2. For the measurement point of case temperature( $T_C$ ), please refer to Fig. 2.

**Electrical Characteristics** ( $T_J = 25^\circ\text{C}$ , Unless Otherwise Specified)**Converter Part**

Item	Symbol	Condition	Min.	Typ.	Max.	Unit
IGBT saturation voltage	$V_{CE(sat)}$	$V_{CC} = 15\text{ V}$ , $V_{IN} = 5\text{ V}$ ; $I_C = 50\text{ A}$	-	2.0	2.5	V
High-side diode voltage	$V_{FH}$	$I_F = 50\text{ A}$	-	2.4	2.9	V
Low-side diode voltage	$V_{FL}$	$I_F = 50\text{ A}$	-	1.2	1.6	V
Switching Times	$t_{ON}$	$V_{PN} = 400\text{ V}$ , $V_{CC} = 15\text{ V}$ , $I_C = 60\text{ A}$ $V_{IN} = 0\text{ V} \leftrightarrow 5\text{ V}$ , Inductive Load (Note 3)	-	560	-	ns
	$t_{C(ON)}$		-	270	-	ns
	$t_{OFF}$		-	520	-	ns
	$t_{C(OFF)}$		-	110	-	ns
	$t_{rr}$		-	44	-	ns
	$I_{rr}$		-	6.5	-	A
Current sensing resistor	$R_{SENSE}$		1.8	2.0	2.2	$\text{m}\Omega$
Collector - emitter Leakage Current	$I_{CES}$	$V_{CE} = V_{CES}$	-	-	250	$\mu\text{A}$

**Note**

3.  $t_{ON}$  and  $t_{OFF}$  include the propagation delay time of the internal drive IC.  $t_{C(ON)}$  and  $t_{C(OFF)}$  are the switching time of IGBT itself under the given gate driving condition internally. For the detailed information, please see Fig. 4

**Control Part**

Item	Symbol	Condition	Min.	Typ.	Max.	Unit
Quiescent $V_{CC}$ Supply Current	$I_{QCCL}$	$V_{CC} = 15\text{ V}$ , $I_N = 0\text{ V}$   $V_{CC} - \text{COM}$	-	-	26	mA
Fault Output Voltage	$V_{FOH}$	$V_{SC} = 0\text{ V}$ , $V_{FO}$ Circuit: 4.7 k $\Omega$ to 5 V Pull-up	4.5	-	-	V
	$V_{FOL}$	$V_{SC} = 1\text{ V}$ , $V_{FO}$ Circuit: 4.7 k $\Omega$ to 5 V Pull-up	-	-	0.8	V
Over Current Trip Level	$V_{SC(ref)}$	$V_{CC} = 15\text{ V}$	0.45	0.5	0.55	V
Supply Circuit Under-Voltage Protection	$UV_{CCD}$	Detection Level	10.7	11.9	13.0	V
	$UV_{CCR}$	Reset Level	11.2	12.4	13.2	V
Fault-out Pulse Width	$t_{FOD}$	$C_{FOD} = 33\text{ nF}$ (Note 4)	1.4	1.8	2.0	ms
ON Threshold Voltage	$V_{IN(ON)}$	Applied between IN - COM	3.0	-	-	V
OFF Threshold Voltage	$V_{IN(OFF)}$		-	-	0.8	V
Resistance of Thermistor	$R_{TH}$	@ $T_C = 25^\circ\text{C}$ (Note Fig. 9)	-	50	-	k $\Omega$
		@ $T_C = 80^\circ\text{C}$ (Note Fig. 9)	-	5.76	-	k $\Omega$

**Note**

4. The fault-out pulse width  $t_{FOD}$  depends on the capacitance value of  $C_{FOD}$  according to the following approximate equation:  $C_{FOD} = 18.3 \times 10^{-6} \times t_{FOD}[\text{F}]$

**Recommended Operating conditions**

Item	Symbol	Condition	Min.	Typ.	Max.	Unit
Input Supply Voltage	$V_I$	Applied between R - S	180	-	264	$V_{rms}$
Output Voltage	$V_{PN}$	Applied between P - N	-	280	400	V
Control Supply Voltage	$V_{CC}$	Applied between $V_{CC} - \text{COM}$	13.5	15	16.5	V
Control Supply Variation	$dV_{CC}/dt$	Applied between IN - COM	-1	-	1	V/ $\mu\text{s}$
PWM Input Signal	$f_{PWM}$	$T_C \leq 100^\circ\text{C}$ , $T_J \leq 125^\circ\text{C}$ , Per IGBT	-	20	-	kHz

### Electrical Characteristics

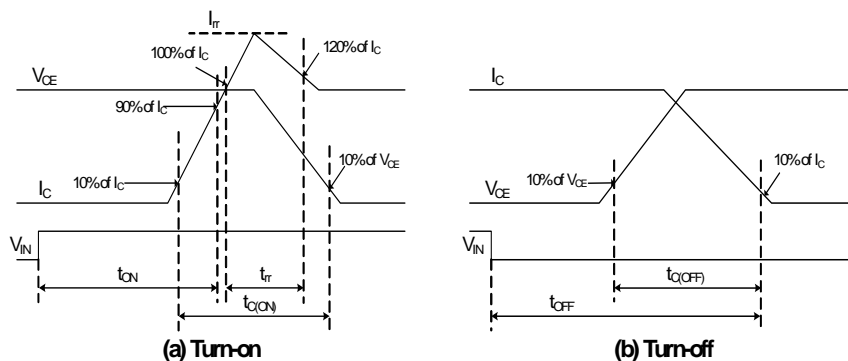

Fig. 4. Switching Time Definition

### Mechanical Characteristics and Ratings

Item	Condition	Limits			Units
		Min.	Typ.	Max.	
Mounting Torque	Mounting Screw: M3   Recommended 0.62 N•m	0.51	0.62	0.72	N•m
Device Flatness	Note Fig. 5	0	-	+120	μm
Weight		-	15.00	-	g

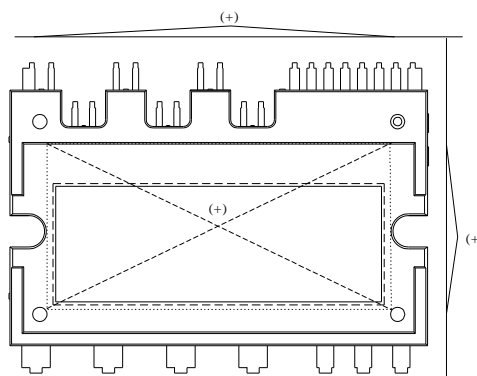
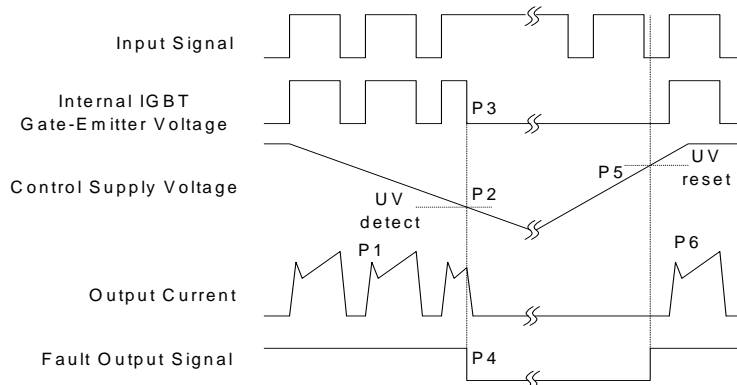

Fig. 5. Flatness Measurement Position

### Time Charts of SPMs Protective Function



- P1 : Normal operation - IGBT ON and conducting current
- P2 : Under voltage detection
- P3 : IGBT gate interrupt
- P4 : Fault signal generation
- P5 : Under voltage reset
- P6 : Normal operation - IGBT ON and conducting current

**Fig. 6. Under-Voltage Protection**

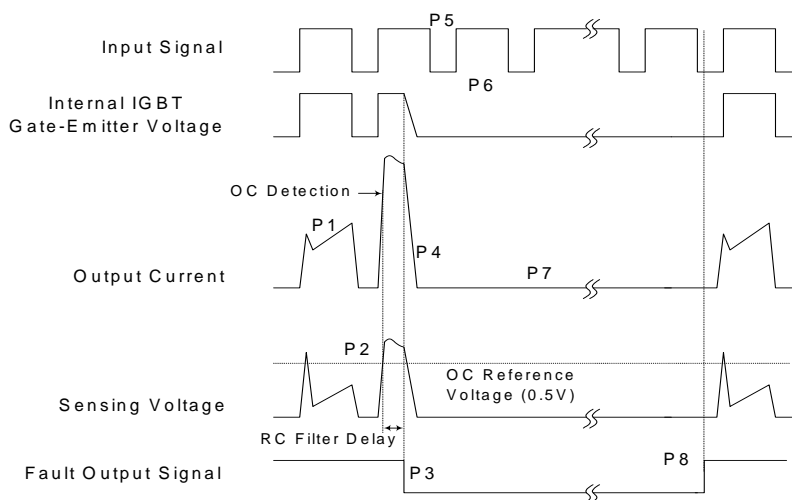

- P1 : Normal operation - IGBT ON and conducting current
- P2 : Over current detection
- P3 : IGBT gate interrupt / Fault signal generation
- P4 : IGBT is slowly turned off
- P5 : IGBT OFF signal
- P6 : IGBT ON signal - but IGBT cannot be turned on during the fault Output activation
- P7 : IGBT OFF state
- P8 : Fault Output reset and normal operation start

**Fig. 7. Over Current Protection**

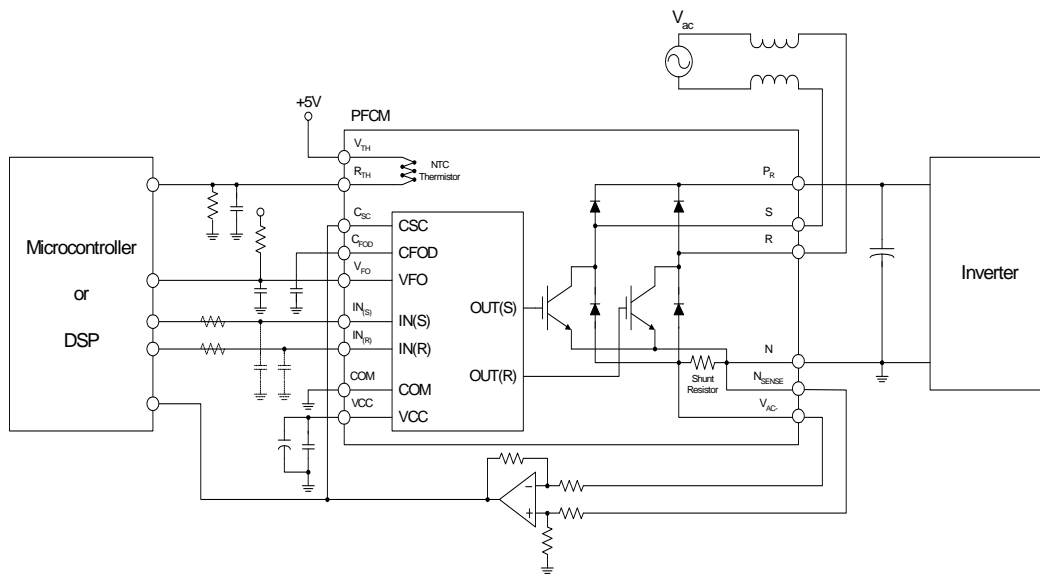

**Note :**  
 1) For the over-current protection, please set the delay time in the range 3 ~ 4  $\mu$ s.

**Fig. 8. Application Example**

**R-T Graph**

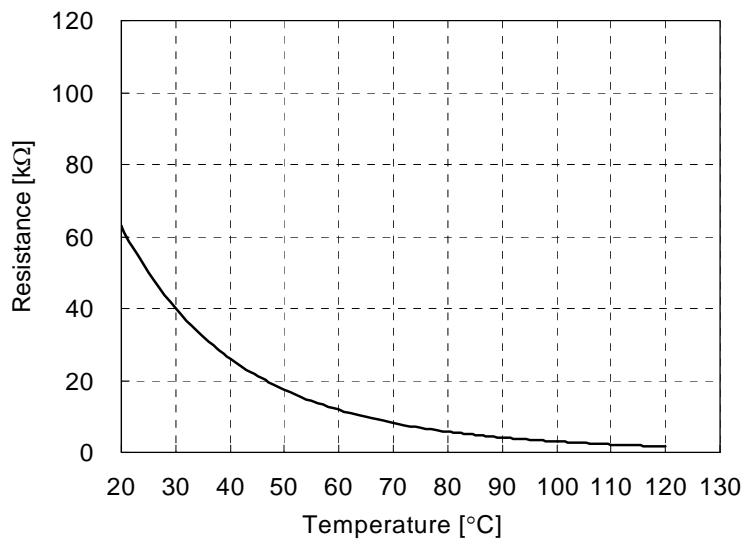

**Fig. 9. R-T Curve of the Built-in Thermistor**



Detailed Package Outline Drawings

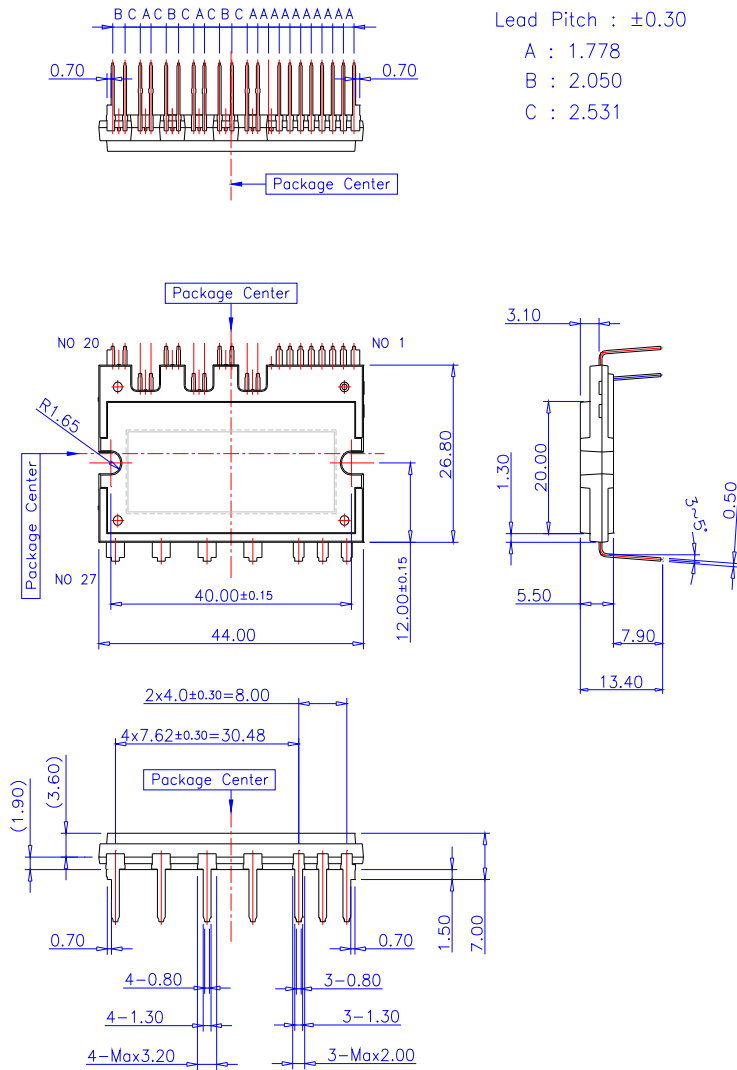

Detailed Package Outline Drawings

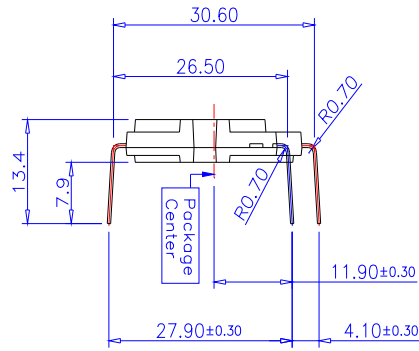

Lead Forming Dimension

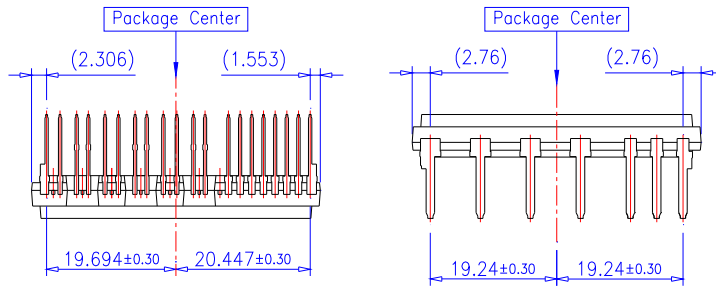

PKG Center to Lead Distance

Detailed Package Outline Drawings

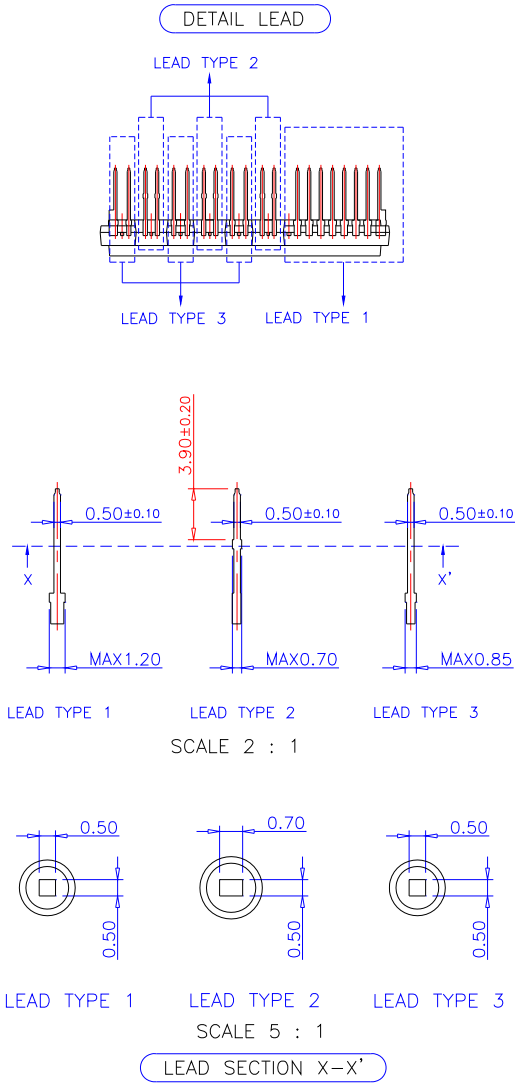



## TRADEMARKS

The following includes registered and unregistered trademarks and service marks, owned by Fairchild Semiconductor and/or its global subsidiaries, and is not intended to be an exhaustive list of all such trademarks.

2Cool™	FPST™		Sync-Lock™
AccuPower™	F-PFST™	PowerTrench®	 SYSTEM GENERAL®
AX-CAP®*	FRFET®	PowerXS™	TinyBoost™
BitSiC™	Global Power Resource™	Programmable Active Droop™	TinyBuck™
Build it Now™	GreenBridge™	QFET®	TinyCalc™
CorePLUSTM	Green FPS™	QST™	TinyLogic®
CorePOWER™	Green FPS™ e-Series™	Quiet Series™	TINYOPTO™
CROSSVOL7™	Gmax™	RapidConfigure™	TinyPower™
CTL™	GTO™		TinyPWM™
Current Transfer Logic™	IntelliMAX™	Saving our world, 1mW/W at a time™	TinyWire™
DEUXPEED®	ISOPLANAR™	SignalWise™	TransiC™
Dual Cool™	Making Small Speakers Sound Louder and Better™	SmartMax™	TriFault Detect™
EcoSPARK®	MegaBuck™	SMART START™	TRUECURRENT®*
EfficientMax™	MICROCOUPLER™	Solutions for Your Success™	µSerDes™
ESBC™	MicroFET™	SPM®	 SerDes™
 Fairchild®	MicroPak™	STEALTH™	UHC®
Fairchild Semiconductor®	MicroPak2™	SuperFET®	Ultra FRFET™
FACT Quiet Series™	MillerDrive™	SuperSOT™.3	UniFET™
FACT®	MotionMax™	SuperSOT™.6	Vcx™
FAST®	mWSaver™	SuperSOT™.8	VisualMax™
FastvCore™	OptoHiT™	SupreMOS®	VoltagePlus™
FETBench™	OPTOLOGIC®	SyncFET™	XS™
	OPTOPLANAR®		

\* Trademarks of System General Corporation, used under license by Fairchild Semiconductor.

## DISCLAIMER

FAIRCHILD SEMICONDUCTOR RESERVES THE RIGHT TO MAKE CHANGES WITHOUT FURTHER NOTICE TO ANY PRODUCTS HEREIN TO IMPROVE RELIABILITY, FUNCTION, OR DESIGN. FAIRCHILD DOES NOT ASSUME ANY LIABILITY ARISING OUT OF THE APPLICATION OR USE OF ANY PRODUCT OR CIRCUIT DESCRIBED HEREIN; NEITHER DOES IT CONVEY ANY LICENSE UNDER ITS PATENT RIGHTS, NOR THE RIGHTS OF OTHERS. THESE SPECIFICATIONS DO NOT EXPAND THE TERMS OF FAIRCHILD'S WORLDWIDE TERMS AND CONDITIONS, SPECIFICALLY THE WARRANTY THEREIN, WHICH COVERS THESE PRODUCTS.

## LIFE SUPPORT POLICY

FAIRCHILD'S PRODUCTS ARE NOT AUTHORIZED FOR USE AS CRITICAL COMPONENTS IN LIFE SUPPORT DEVICES OR SYSTEMS WITHOUT THE EXPRESS WRITTEN APPROVAL OF FAIRCHILD SEMICONDUCTOR CORPORATION.

As used herein:

1. Life support devices or systems are devices or systems which, (a) are intended for surgical implant into the body or (b) support or sustain life, and (c) whose failure to perform when properly used in accordance with instructions for use provided in the labeling, can be reasonably expected to result in a significant injury of the user.
2. A critical component in any component of a life support, device, or system whose failure to perform can be reasonably expected to cause the failure of the life support device or system, or to affect its safety or effectiveness.

## ANTI-COUNTERFEITING POLICY

Fairchild Semiconductor Corporation's Anti-Counterfeiting Policy. Fairchild's Anti-Counterfeiting Policy is also stated on our external website, [www.fairchildsemi.com](http://www.fairchildsemi.com), under Sales Support.

Counterfeiting of semiconductor parts is a growing problem in the industry. All manufacturers of semiconductor products are experiencing counterfeiting of their parts. Customers who inadvertently purchase counterfeit parts experience many problems such as loss of brand reputation, substandard performance, failed applications, and increased cost of production and manufacturing delays. Fairchild is taking strong measures to protect ourselves and our customers from the proliferation of counterfeit parts. Fairchild strongly encourages customers to purchase Fairchild parts either directly from Fairchild or from Authorized Fairchild Distributors who are listed by country on our web page cited above. Products customers buy either from Fairchild directly or from Authorized Fairchild Distributors are genuine parts, have full traceability, meet Fairchild's quality standards for handling and storage and provide access to Fairchild's full range of up-to-date technical and product information. Fairchild and our Authorized Distributors will stand behind all warranties and will appropriately address any warranty issues that may arise. Fairchild will not provide any warranty coverage or other assistance for parts bought from Unauthorized Sources. Fairchild is committed to combat this global problem and encourage our customers to do their part in stopping this practice by buying direct or from authorized distributors.

## PRODUCT STATUS DEFINITIONS

### Definition of Terms

Datasheet Identification	Product Status	Definition
Advance Information	Formative / In Design	Datasheet contains the design specifications for product development. Specifications may change in any manner without notice.
Preliminary	First Production	Datasheet contains preliminary data; supplementary data will be published at a later date. Fairchild Semiconductor reserves the right to make changes at any time without notice to improve design.
No Identification Needed	Full Production	Datasheet contains final specifications. Fairchild Semiconductor reserves the right to make changes at any time without notice to improve the design.
Obsolete	Not In Production	Datasheet contains specifications on a product that is discontinued by Fairchild Semiconductor. The datasheet is for reference information only.

Rev. I64