

NOIS1SM0250A

STAR250 250K Pixel Radiation Tolerant CMOS Image Sensor

Features

- 512 x 512 Active Pixels
- 25 μm Pixel Size
- 1 inch Optical Format
- Up to 30 Frames per Second (fps) at Full Resolution
- 8 MHz Maximum Data Rate/Master Clock
- 3340 $\text{V}\cdot\text{m}^2/\text{W}\cdot\text{s}$ Sensitivity
- 74 dB (5000:1) Dynamic Range
- 76 e^- kTC Noise
- 4750 e^-/s at RT Dark Current
- 5 V Supply Voltage
- Operating Temperature Range
 - ◆ -40°C to $+85^\circ\text{C}$
- Gamma Total Dose Radiation Tolerance:
 - ◆ Increase in Average Dark Current $< 1 \text{ nA}/\text{cm}^2$ after 3 MRad
 - ◆ Image Operation with Dark Signal $< 1 \text{ V/s}$ after 10 Mrad Demonstrated (Co60)
- Proton Radiation Tolerance:
 - ◆ 1% of Pixels has an Increase in Dark Current $> 1 \text{ nA}/\text{cm}^2$ after $3 \cdot 10^{10}$ Protons at 11.7 MeV
- SEL Threshold $> 80 \text{ MeV cm}^3 \text{ mg}^{-1}$
- Less than 350 mW Power Consumption
- These Devices are Pb-Free and are RoHS Compliant

Overview

The STAR250 sensor is a CMOS active pixel sensor featuring 512 x 512 pixels on a 25 mm pitch, on chip fixed pattern noise (FPN) correction, a programmable gain amplifier, and a 10-bit ADC. Flexible operating (multiple windowing, sub-sampling) is possible by direct addressable X and Y registers.

The sensor has an outstanding radiation tolerance that is observed using proprietary technology modifications and design techniques. The STAR250 utilizes a BK7G18 glass lid with anti reflective coating. The cavity is filled with N_2 increasing the temperature operating range.

ORDERING INFORMATION

Marketing Part Number	Description	Package
NOIS1SM0250A-HHC	Mono with BK7G18 glass	84-pin JLCC case 114AK
NOIS1SM0250A-WWC	Mono wafer	Wafer Sales

NOTE: Refer to Ordering Code Definition on page 3 for more information.



ON Semiconductor®

<http://onsemi.com>

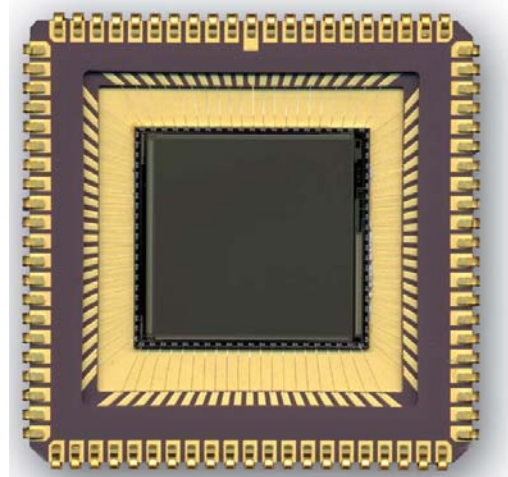

Figure 1. STAR250 Photograph

JLCC84
CASE 114AK

Applications

- Applications Requiring Higher Pixel Pitch
- Scientific Applications Requiring Radiation Tolerance
- Nuclear Inspection

CONTENTS

NOIS1SM0250A

Features	1	Analog-to-Digital Converter	12
Applications	1	Timing and Readout of Image Sensor	12
Overview	1	Image Readout Procedure	12
Ordering Information	1	Loading the X and Y Start Positions	14
Contents	2	Other Signals	15
Ordering Code Definition	3	Pin List	16
Marking	3	Package Dimensions	20
Specifications	4	Die Alignment	21
Electrical Specifications	7	Soldering and Handling	22
Sensor Architecture	10	Handling Precautions	22
Pixel Structure	10	Limited Warranty	22
Shift Registers	11	RoHS (Pb-free) Compliance	22
Column Amplifiers	11	Acceptance Criteria Specification	22
Electronic Shutter	11	Acronyms	23
Programmable Gain Amplifier	12	Glossary	24

NOIS1SM0250A

ORDERING CODE DEFINITION

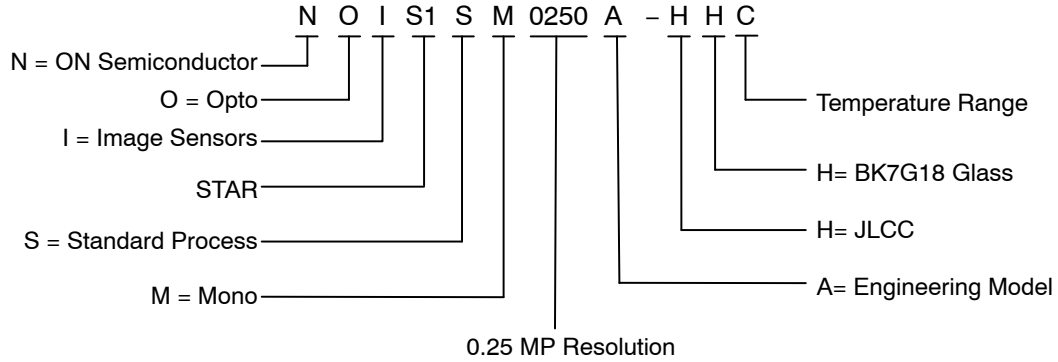

Marking

The marking shall consist of a lead identification and traceability information.

Lead Identification

An index to pin 1 shall be located on the top of the package as shown in section Package Dimensions on page 21. The pin numbering is counter clock-wise, when looking at the top-side of the component.

Traceability Information Tests

Each component shall be marked such that complete traceability can be maintained.

The component shall bear a number that is constituted as follows:

Orderable Part Number	Package Mark: Line 1	Package Mark: Line 2	Package Mark: Line 3
NOIS1SM0250A-HHC	NOIS1SM0250A	-HHC_NNNN	AWLYYWW
where NNNN- serialized number controlled manually by ON Semiconductor, BELGIUM			
where AWLYYWW represents the lot assembly date			

MARKING DIAGRAM

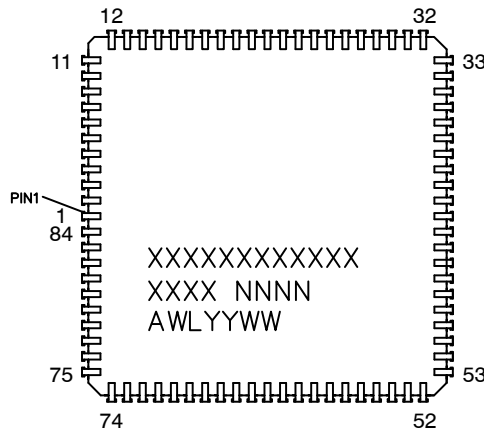

XXXXXX = Specific Device Code
 A = Assembly Location
 WL = Wafer Lot
 YY = Year
 WW = Work Week
 NNNN = Serial Number

NOIS1SM0250A

SPECIFICATIONS

Table 1. GENERAL SPECIFICATIONS

Parameter	Specification	Remarks
Pixel architecture	3 transistor active pixel 4 diodes per pixel	Radiation-tolerant pixel design 4 photodiodes for improved MTF
Pixel size	25 x 25 μm^2	
Resolution	512 x 512 pixels	
Pixel rate	8 Mps	
Shutter type	Electronic	Integration time is variable, steps equal to the row readout time
Frame rate	29 full frames/second	
Extended dynamic range	Double slope	
Programmable gain	Programmable between x1, x2, x4, x8	Selectable through pins G0 and G1
Supply voltage V_{DD}	5 V	
Operational temperature range	-40°C to +85°C	Nitrogen in cavity
Package	84-pin JLCC	

Table 2. ELECTRO-OPTICAL SPECIFICATIONS

Parameter	Specification (Typical)	Comment
Detector technology	CMOS active pixel sensor	
Pixel structure	3-transistor active pixel 4 diodes per pixel	Radiation-tolerant pixel design 4 photodiodes for improved MTF
Photodiode	High fill factor photodiode	
Sensitive area format	512 by 512 pixels	
Pixel size	25 μm^2 x 25 μm^2	
Spectral range	200 nm to 1000 nm	See Figure 2 and Figure 3
Quantum efficiency x fill factor	Maximum 35%	Above 20% between 450 nm and 750 nm (Metal FillFactor (MFF) is 63%)
Full well capacity	311K electrons	When output amplifier gain = 1
Linear range within +1%	128K electrons	When output amplifier gain = 1
Output signal swing	1.68 V	When output amplifier gain = 1
Conversion gain	5.7 $\mu\text{V}/e^-$	When output amplifier gain = 1 near dark
Temporal noise	76 e^-	Dominated by kTC
Dynamic range	74 dB (5000:1)	At the analog output
FPN	1 < 0.1% of full well (typical)	Measured local, on central image area 50% of pixels in the dark
PRNU (photo response nonuniformity)	Local: 1 = 0.39% of response Global: 1 = 1.3% of response	Measured in central image area 50% of pixels, at Qsat/2
Average dark current signal	4750 e^-/s	At RT
DSNU (dark signal nonuniformity)	3805 e^-/s RMS	At RT, scale linearly with integration time
MTF	Horizontal: 0.36 Vertical: 0.39	at 600 nm.
Optical cross talk	5% to nearest neighbor if central pixel is homogeneously illuminated	

NOIS1SM0250A

Table 2. ELECTRO-OPTICAL SPECIFICATIONS

Parameter	Specification (Typical)	Comment
Antiblooming capacity	x 1000 to x 100 000	
Output amplifier gain	1, 2, 4, or 8	Controlled by two bits
Windowing	X and Y 9-bit programmable shift registers	Indicate upper left pixel of each window
Electronic shutter range	1: 512	Integration time is variable in time steps equal to the row readout time
ADC	10-bit	
ADC linearity	±3.5 counts	INL
Missing codes	none	
ADC setup time	310 ns	To reach 99% of final value
ADC delay time	125 ns	
Power dissipation	< 350 mW	Average at 8 MHz pixel rate

Spectral Response Curve

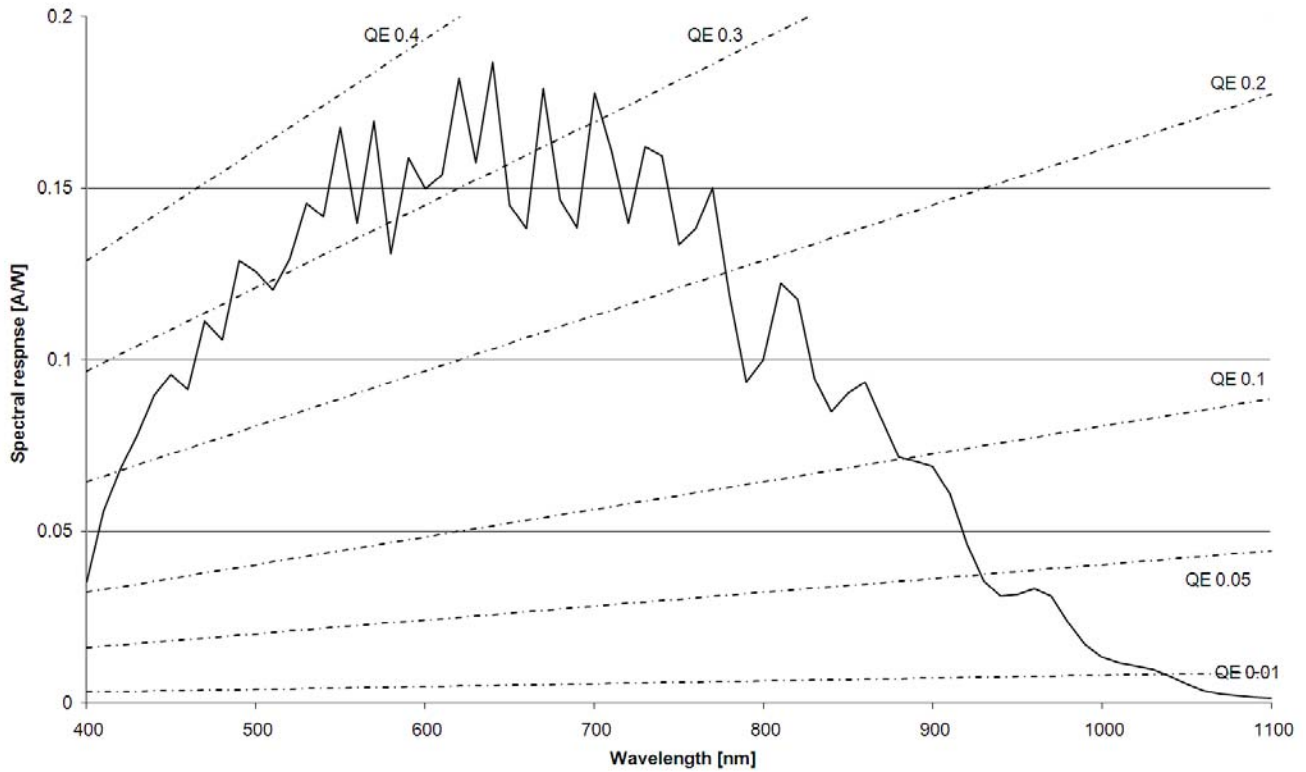

Figure 2. Spectral Response Curve

NOIS1SM0250A

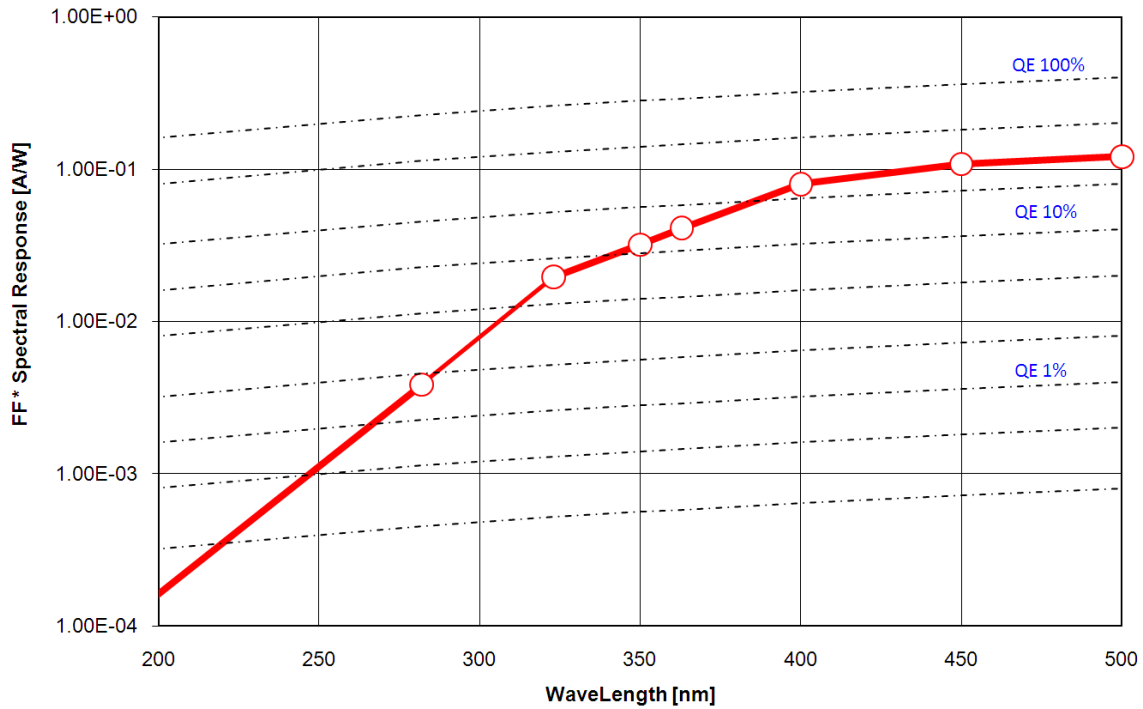

Figure 3. UV Region Spectral Response Curve

Pixel Profile

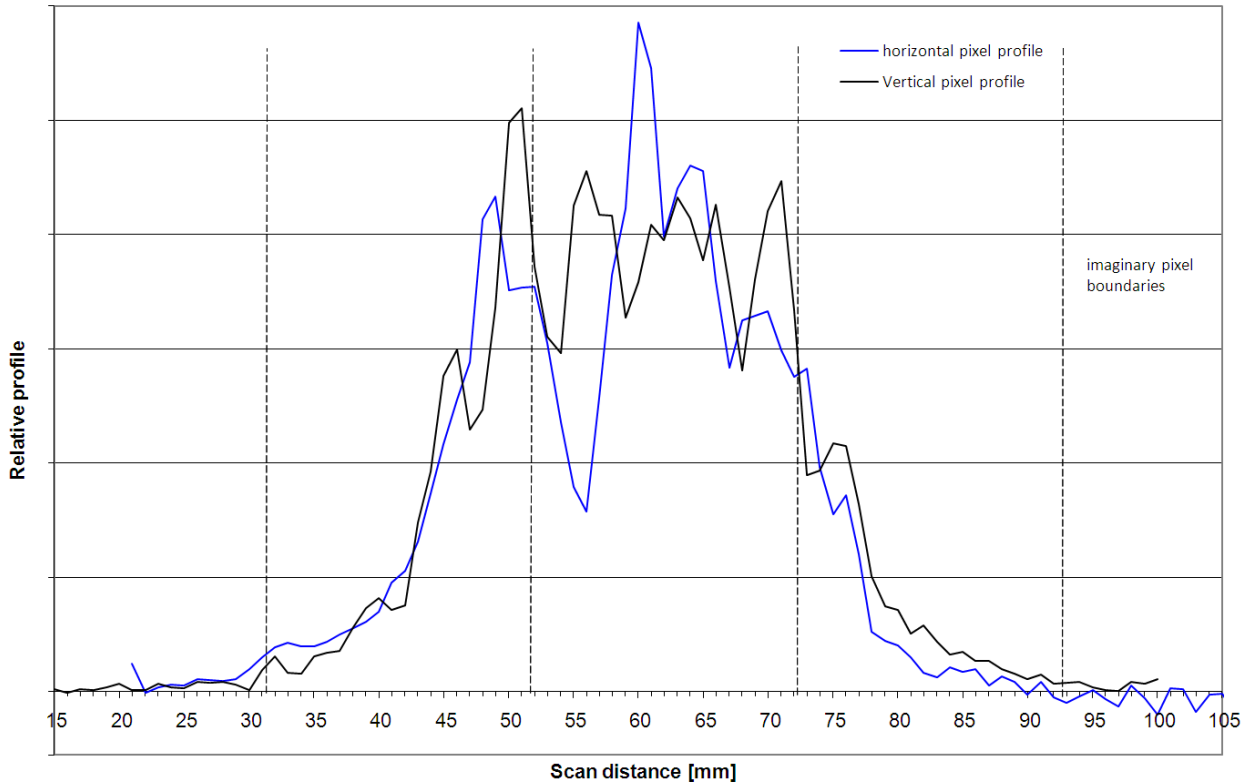

Figure 4. Pixel Profile

The pixel profile is measured using the 'knife edge' method: the image of a target containing a black to white transition is scanned over a certain pixel with subpixel resolution steps. The sensor settings and illumination

conditions are adjusted such that the transition covers 50% of the output range. The scan is performed both horizontal and vertical.

NOIS1SM0250A

Electrical Specifications

Absolute Maximum Ratings

Absolute ratings are those values beyond which damage to the device may occur.

Table 3. ABSOLUTE MAXIMUM RATINGS STAR250BK7

Characteristics	Limits		Units	Remarks
	Min	Max		
Any supply voltage	-0.5	+7	V	
Voltage on any input terminal	-0.5	V _{DD} + 0.5	V	
Storage temperature	-40	+85	°C	
	-40	+120	°C	Maximum 1 hour
Sensor soldering temperature	NA	125	°C	Hand soldering only. The sensor's temperature during soldering should not exceed this limit.

Stresses exceeding those listed in the Maximum Ratings table may damage the device. If any of these limits are exceeded, device functionality should not be assumed, damage may occur and reliability may be affected.

Table 4. RADIATION TOLERANCE

Parameter	Criterion	Qualification level
Gamma total dose radiation tolerance	Increase in average dark current < 1 nA/cm ² after 3 MRad	See Figure 5
	Image operation with dark signal < 1V/s	10 Mrad demonstrated (Co60)
	Single (test) pixel operation with dark signal < 1V/s	24 Mrad demonstrated (Co60)
Proton radiation tolerance	1% of pixels has an increase in dark current > 1 nA/cm ² after 3 x 10 ¹⁰ protons at 11.7 MeV	See Figure 5
SEL threshold	> 80 MeV cm ³ mg ⁻¹	To be confirmed

NOIS1SM0250A

Figure 5 shows the increase in dark current under total dose irradiation. This curve is measured when the radiation is at high dose rate. Annealing results in a significant dark current decrease.

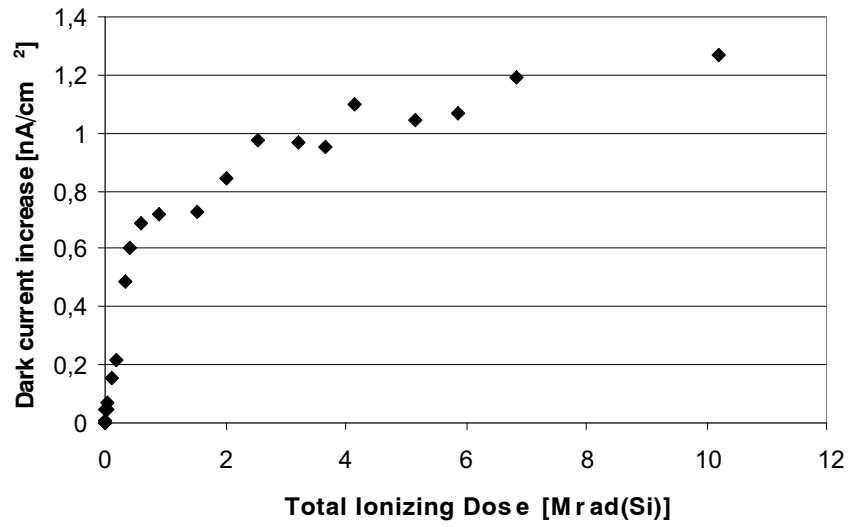

Figure 5. Dark Current Increase

Figure 6 shows the percentage of pixels with a dark current increase under 11.7 MeV radiation with protons.

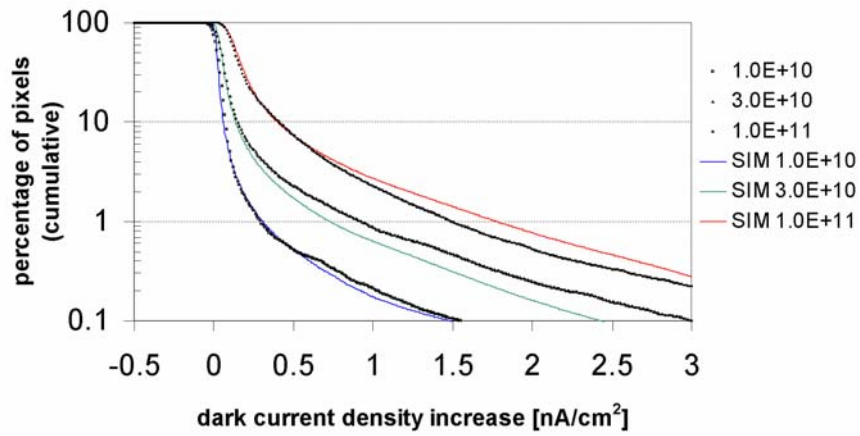

Figure 6. Percentage of Pixels with Dark Current Increase

NOIS1SM0250A

DC Operating Conditions

Table 5. DC SPECIFICATIONS

Symbol	Parameter (Notes 1, 2 and 3)	Min	Typ	Max	Units
V _{DD_ANA}	Analog supply voltage to imager part	–	5	–	V
V _{DD_DIG}	Digital supply voltage to imager part	–	5	–	V
V _{DD_ADC_ANA}	Analog supply voltage to ADC	–	5	–	V
V _{DD_ADC_DIG}	Digital supply voltage to ADC	–	5	–	V
V _{DD_ADC_DIG_3.3/5}	Supply voltage of ADC output stage	–	3.3 to 5	–	V
V _{IH}	Logical '1' input voltage	2.3	–	V _{DD}	V
V _{IL}	Logical '0' input voltage	0	–	1	V
V _{OH}	Logical '1' output voltage	4.25	4.5	–	V
V _{OL}	Logical '0' output voltage	–	0.1	1	V
V _{DD_PIX}	Pixel array power supply (default 5 V, the device is then in 'soft reset'. To avoid the image lag associated with soft reset, reduce this voltage to 3–3.5 V 'hard reset')	–	5	–	V
V _{DD_RESL}	Reset power supply	–	5	–	V

1. All parameters are characterized for DC conditions after establishing thermal equilibrium.
2. Unused inputs must always be tied to an appropriate logic level, for example, either V_{DD} or GND.
3. This device contains circuitry to protect the inputs against damage due to high static voltages or electric fields. Take normal precautions to avoid applying any voltages higher than the maximum rated voltages to this high impedance circuit.

NOIS1SM0250A

SENSOR ARCHITECTURE

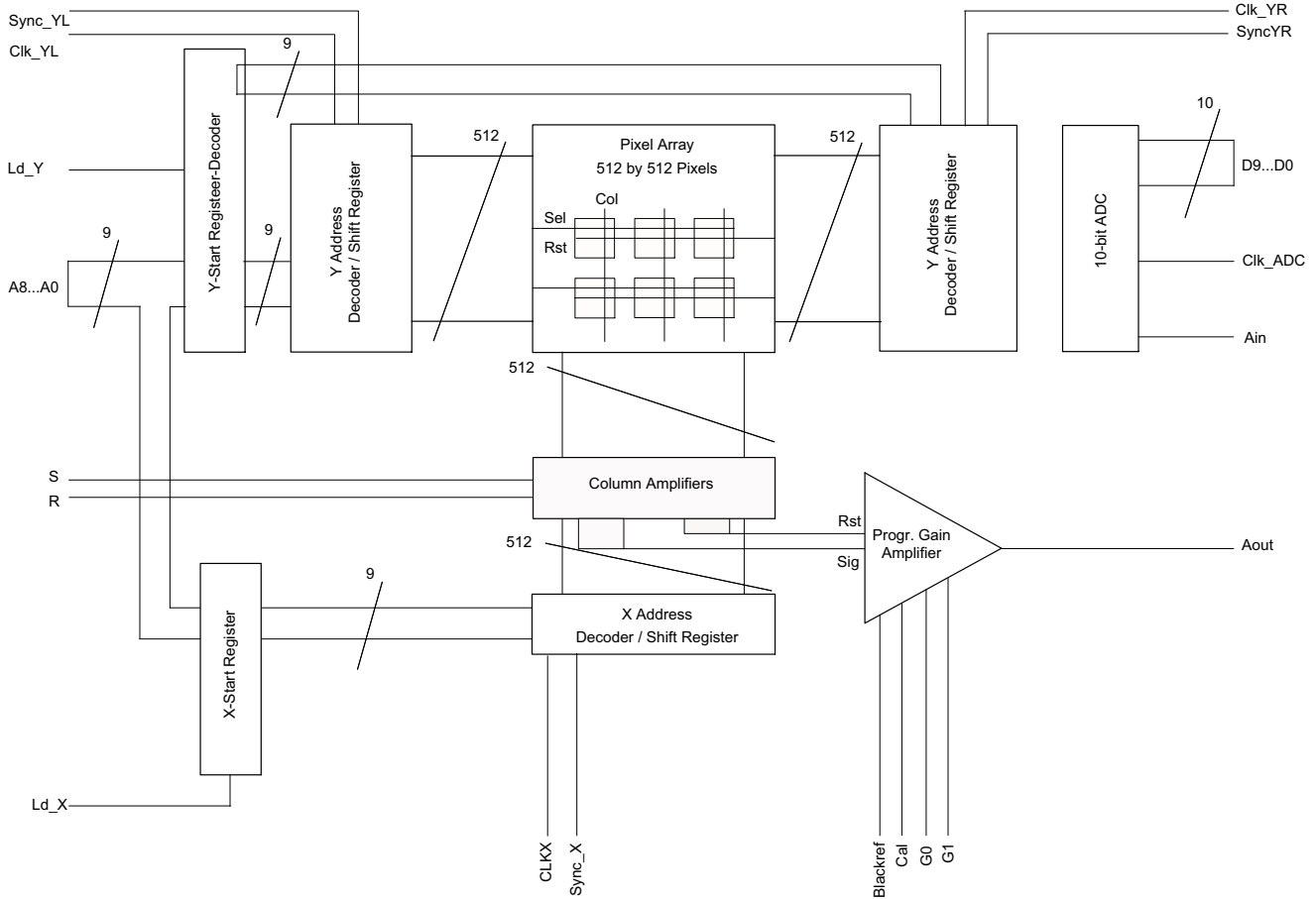

Figure 7. STAR250 Schematic

The base line of the STAR250 sensor design consists of an imager with a 512 by 512 array of active pixels at 25 μm pitch. The detector contains on-chip correction for FPN in the column amplifiers, a programmable gain output amplifier, and a 10-bit ADC. Through additional preset registers, the start position of a window can be programmed to enable fast read out of only part of the detector array.

Pixel Structure

The image sensor consists of several building blocks as outlined in Figure 7. The central element is a 512 by 512 pixel array with square pixels at 25 μm pitch. Unlike classical designs, the pixels of this sensor contain four photodiodes. This configuration enhances the MTF and reduces the PRNU. Figure 8 shows an electrical diagram of the pixel structure. The four photodiodes are connected in parallel to the reset transistor (T1). Transistor T2 converts the charge, collected on the photo diode node, to a voltage

signal that is connected to the column bus by T3. The reset and read entrance of the pixel are connected to one of the Y shift registers.

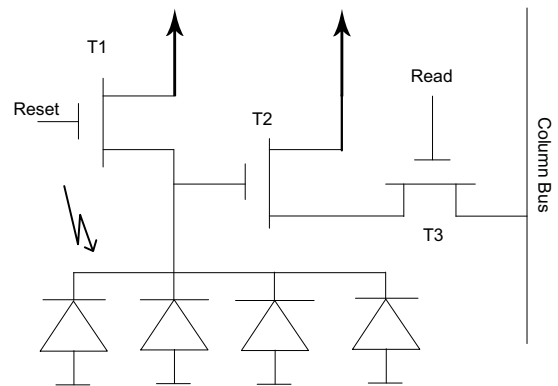

Figure 8. STAR250 Pixel Structure

Shift Registers

The shift registers are located next to the pixel array and contain equal number of outputs and pixel array rows. They are designed as “1-hot” registers, (YL and YR shift register) each allowing selection of one row of pixels at a time. A clock pulse moves the pointer one position down the register resulting in the selection of every individual row for either reset or readout. The spatial offset between the two selected rows determines the integration time. A synchronization pulse to the shift registers loads the value from a preset register into the shift register forcing the pointer to a predetermined position. Windowing in the vertical (Y) direction is achieved by presetting the registers to a row that is not the first row and by clocking out only the required number of rows.

Column Amplifiers

All outputs from the pixels in a column are connected in parallel to a column amplifier. This amplifier samples the output voltage and the reset level of the pixel whose row is selected at that moment and presents these voltage levels to the output amplifier. As a result, the pixels are always reset immediately after readout as part of the sample procedure and the maximum integration time of a pixel is the time between two read cycles.

Electronic Shutter

In a linescan integrating imager with electronic shutter, there are two continuous processes of image gathering.

The first process resets lines in a progressive scan. At line reset, all the pixels in a line are drained from any photo charges collected since their last reset or readout. After reset, a new exposure cycle starts for that particular line.

The second process is the actual readout, which also happens in an equally fast linewise progressive scan.

During readout, the photo charges collected since the previous reset are converted into an output voltage. This is then passed on pixel by pixel to the imager’s pixel serial output and ADC. Readout is destructive, meaning the accumulation of charges from successive exposure phases is not possible in the present architecture.

The STAR250 has two Y shift registers; YL and YR. One is used to read out a line (YL) and the other is used to reset a line (YR). The integration time is equal to the time between the last reset and readout of that line, see Figure 9. The integration time is calculated as follows:

Integration time = (Nr. Lines * (RBT + pixel period * Nr. Pixels)) with:

- Nr. Lines: Number of lines between readout and reset (Y).
- Nr. Pixels: Number of pixels read out each line (X).
- RBT: Row Blanking Time = 3.2 μs (typical).
- Pixel period: 1/8 MHz = 125 ns (typical).

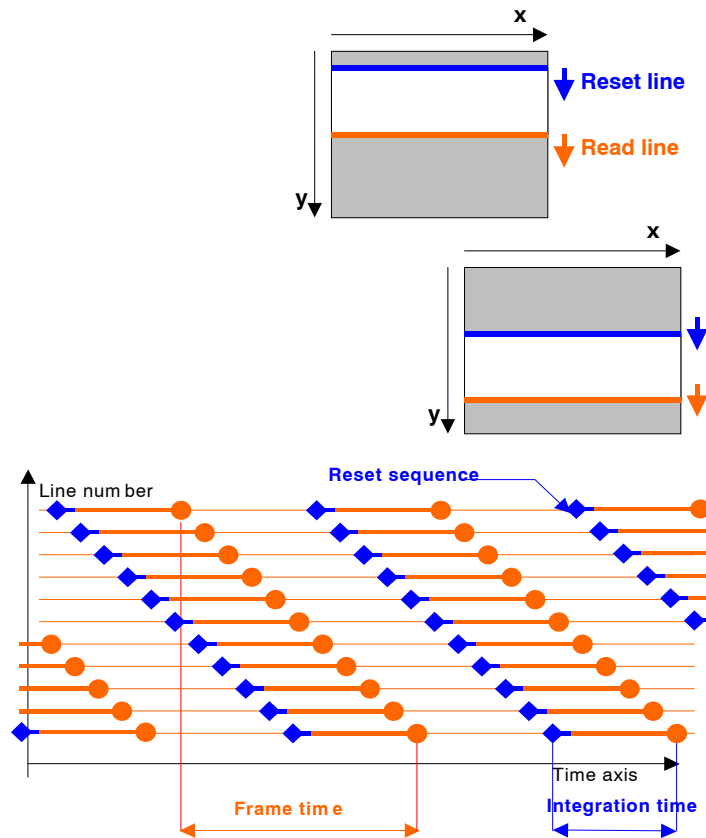

Figure 9. Electronic Shutter

Programmable Gain Amplifier

The signal from the column amplifiers is fed to an output amplifier with four presettable gains (adjustable with pins G0 and G1). The offset correction of this amplifier is done through a black reference procedure. The signal from the output amplifier is externally available on the analog output terminator of the device.

Analog-to-Digital Converter

The on-chip 10-bit ADC is electrically separated from the other circuits of the device. The ADC conversion range is set by the voltages on VLOW_ADC (pin 47) and VHIGH_ADC (pin 70). Make voltages on these pins equal to about 2 V on VLOW_ADC and 4 V on VHIGH_ADC. The voltages are set by connecting VLOW with 1.2 kΩ to GND and VHIGH_ADC with 560 Ω to V_{DD}. This way, a resistor ladder is created as shown in Figure 10.

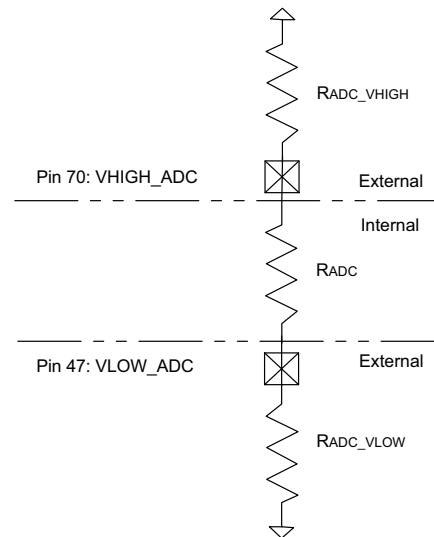

Figure 10. ADC Resistor Ladder

The internal ADC resistance varies according to temperature. The resistance value increases approximately 4.4 Ω/°C with increasing temperature. If the ADC range is set externally with resistors, the conversion range may vary with temperature. This effect is cancelled out by not making use of resistors but directly applying voltages on VLOW_ADC and VHIGH_ADC.

TIMING AND READOUT OF IMAGE SENSOR

Image Readout Procedure

A preamble or initialization phase is irrelevant. The sensor is read out continuously. The first frame is generally saturated and useless because there is no preceding reset of each pixel.

Image Readout

In an infinite uninterrupted loop, follow these steps for every line:

1. Synchronize the read (YL) and/or reset (YR) registers:
 - ◆ SYNC_YL - to reinitiate the readout sequence to row position Y1
 - ◆ SYNC_YR - to reinitiate the reset pointer to row position Y1

For all other lines do not pulse one of these SYNC_Y signals.

2. Operate the double sampling column amplifiers with two RESETs. Apply one to reset the line that is currently selected to produce the reset reference level for the double sampling column amplifiers. Apply the other reset to another line depending on the required integration time reduction.
3. Perform a line readout:
 - ◆ Reset the X read address shift register to the value in its shadow register (X1).
 - ◆ Perform a pixel readout operation, operating the track/hold and the ADC.

- ◆ Shift the X read address shift register one position further.
- ◆ Shift the Y read and reset address shift registers one position further. If either of Y read or reset address shift register comes to the end of the pixel array (or the ROI), wrap it around to the start position by pulsing SYNC_YL.

Readout Timing

The actual line readout process starts with addressing the line to read. This is done either by initializing the YL pointer with a new value or by shifting it one position beyond its previous value. (Addressing the line has reset, YR is done in an analogous fashion). During the “blanking time”, after the new line is addressed on the sensor, the built-in column-parallel double sampling amplifiers are operated. This renders offset-corrected values of the line under readout.

After the blanking time, the pixels of the row addressed by YL are read by multiplexing all the pixels one by one to the serial output chain. The pixel is selected by the X pointer and that pointer is either initialized with a new value or an increment of the previous position.

The time between row resets and their corresponding row readouts is the effective exposure time (or integration time). This time is proportional to the number of lines (DelayLines) between the line currently under reset and the line currently under readout: DelayLines = (YR - YL+1).

NOIS1SM0250A

This time is also equal to the delay between the SYNC_YR pulse and the subsequent SYNC_YR.

The effective integration time tint is calculated as delaylines x line time. The line time is a function of four

terms: the time to output the desired number of pixels in the line (Wframe) and the overhead (“blinking”) time needed to select a new line and perform the double sampling and reset operations.

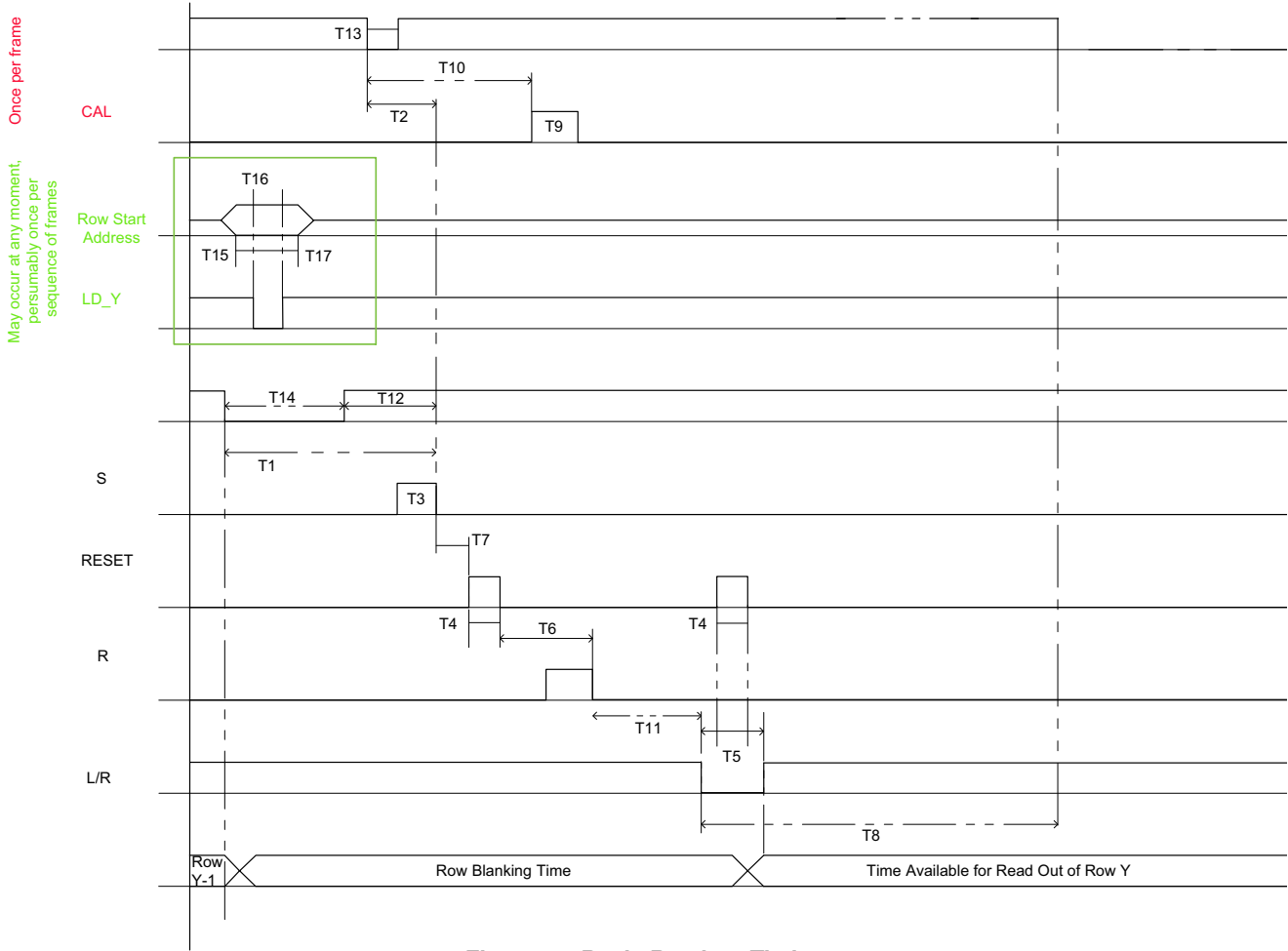

Figure 11. Basic Readout Timing

SYNC_YR is not identical to SYNC_YL. SYNC_YR is used in electronic shutter operation. The CLK_YR is driven identical to CLK_YL, but the SYNC_YR pulse leads the SYNC_YL pulse by a certain number of rows. This lead time is the effective integration (electronic shutter ~) time. Relative to the row timing, both SYNC pulses are given at the same time position, once for each frame, but during different rows.

SYNC_YL is pulsed when the first row is read out and SYNC_YR is pulsed for the electronic shutter to start for this

first row. CAL is pulsed on the first row too, 2 μs later than SYNC_YL.

The minimal idle time is 1.4 μs (before starting reading pixels). However, do not read out pixels during the complete row initialization process (in between the rising edge on S and the falling edge on L/R). In this case, the total idle time is minimal. This timing assumes that the Y start register was loaded in advance, which can occur at any time but before the pulse on SYNC_YL or SYNC_YR.

NOIS1SM0250A

Table 6. READOUT TIMING SPECIFICATIONS

Symbol	Min	Typ	Description
T1	1.8 μ s	–	Delay between selection of new row by falling edge on CLK_YL and falling edge on S. Minimal value. Normally, CLK_YR is low already at the end of the previous sequence.
T2	1.8 μ s	–	Delay between selection of new a row by SYNC_YL and falling edge on S.
T3	0.4 μ s	–	Duration of S and R pulse.
T4	0.1 μ s	–	Duration of RESET pulse.
T5	T4 + 40 ns	0.3 μ s	L/R pulse must overlap second RESET pulse at both sides.
T6	0.8 μ s	–	Delay between falling edge on RESET and falling edge on R.
T7	20 ns	0.1 μ s	Delay between falling edge on S and rising edge on RESET.
T8	0	1 μ s	Delay between falling edge on L/R and falling edge on CLK_Y.
T9	100 ns	1 μ s	Duration of cal pulse. The CAL pulse is given once each frame.
T10	0	2 μ s	Delay between falling edge of SYNC_YL and rising edge of CAL pulse.
T11	40 ns	0.1 μ s	Delay between falling edge on R and rising edge on L/R.
T12	0.1 μ s	1 μ s	Delay between rising edge of CLK_Y and falling edge on S.
T13	–	0.5 μ s	Pulse width SYNC_YL/YR.
T14	–	0.5 μ s	Pulse width CLK_YL/YR.
T15	10 ns	–	Address setup time.
T16	20 ns	–	Load X/Y start register value.
T17	10 ns	–	Address stable after load.
T18	10 ns	–	
T19	20 ns	–	SYNC_X pulse width. SYNC_X while CLK_X is high.
T20	10 ns	–	
T21	–	40 ns	Analog output is stable during CLK_X low.
T22	–	40 ns	CLK_X pulse width: During this clock phase the analog output ramps to the next pixel level.
T23	–	125 ns	ADC digital output stable after falling edge of CLK_ADC.

Loading the X and Y Start Positions

The start positions (start addresses) for region of interest (ROI) are preloaded in the X or Y start register. They become effective by the application of the SYNC_X, SYNC_YL and/or SYNC_YR. The start X or Y address must be applied to their common address bus and the corresponding LD_X or LD_Y pin must be pulsed.

On each falling edge of CLK_X, a new pixel of the same row (line) is accessed. The output stage is in hold when CLK_X is low and starts generating a new output after a rising edge on CLK_X.

The following timing constraints apply:

Load the X or Y start addresses in advance, before the X or Y shift registers are preset by a SYNC pulse. However, if necessary, they can be loaded just before the SYNC_X or SYNC_Y pulse as shown in Figure 12.

For example, the X start register can be loaded during the row idle time. The Y start register can be loaded during readout of the last row of the previous frame.

If the X or Y start address does not change for later frames, it does not need to be reloaded in the register.

NOIS1SM0250A

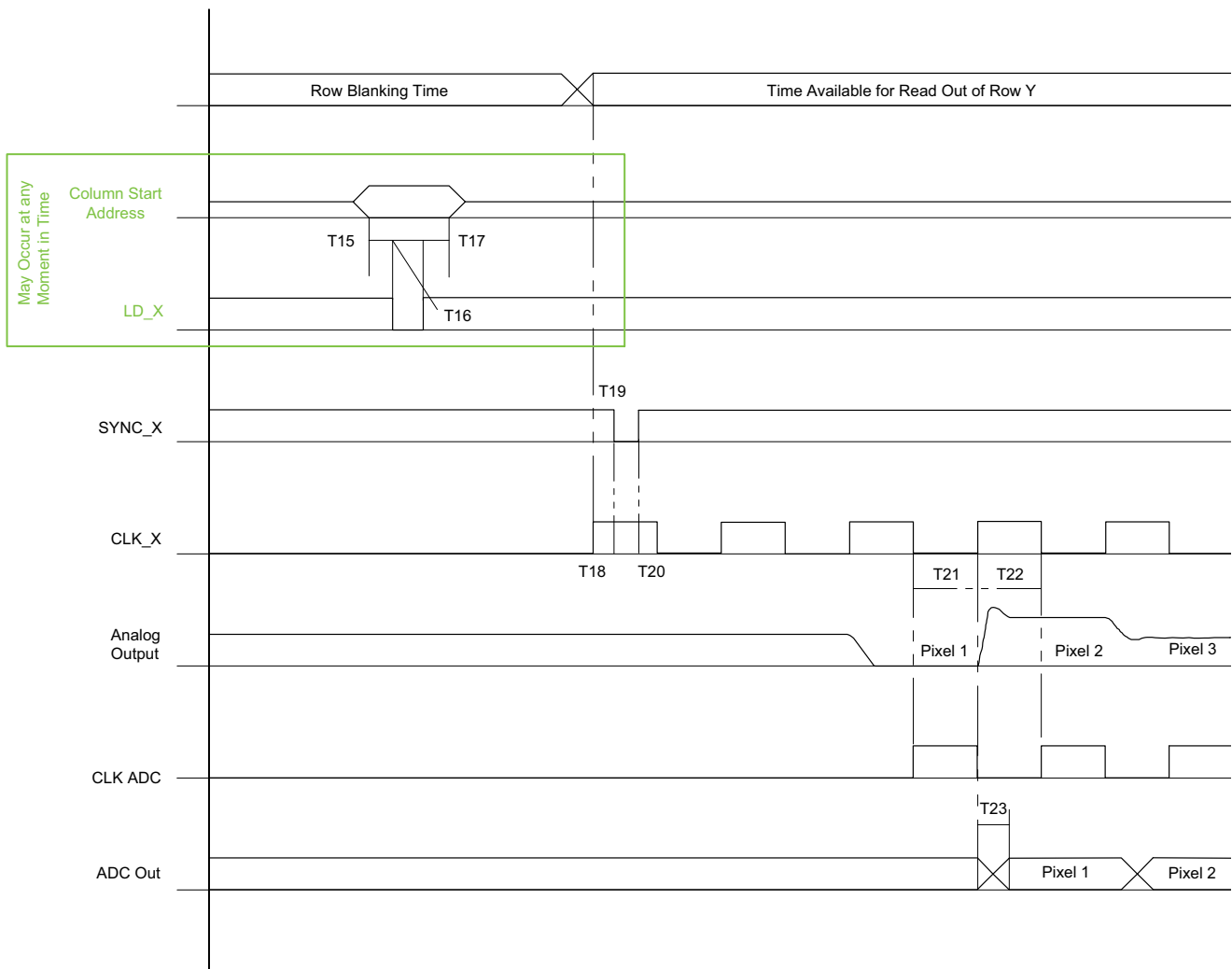

Figure 12. Timing to Load X and Y Registers

Other Signals

Tie SELECT signal to V_{DD} for normal operation. This signal is added for diagnostic reasons and inhibits the pixel array operation when held low.

The CAL signal sets the output amplifier DC offset level. When this signal is active (high) the pixel array is internally disconnected from the output amplifier, its gain is set to unity and its input signal is connected to the BLACK_REF input. Perform this action at least once for each frame.

EOS_X, EOS_YL, and EOS_YR produce a pulse when the respective shift register comes at its end. These outputs are used mainly during testing to verify proper operation of the shift registers.

TESTDIODE and TESTPIXEL_ARRAY are connections to optical test structures that are used for electro optical evaluation. TESTDIODE is a plain photodiode with an area of 14 x 5 pixels. TESTPIXEL_ARRAY is an array (14 x 5) of pixels where the photodiodes are connected in parallel. These structures measure the photocurrent of the diodes directly.

TESTPIXEL_RESET and TESTPIXEL-OUT are connections to a single pixel that are used for testing.

NOIS1SM0250A

PIN LIST

Table 7. POWER SUPPLY CONNECTIONS

Pin	Pin Name	Pin Description
10	V _{DD_ANA}	Analog power supply 5 V
11	V _{DD_DIG}	Digital power supply 5 V
31	V _{DD_AMP}	Power supply of output amplifier 5 V
33	V _{DD_DIG}	Digital power supply 5 V
34	V _{DD_ANA}	Analog power supply 5 V
49	V _{DD_RESR}	Reset power supply 5 V
50	V _{DD_DIG}	Digital power supply 5 V
53	V _{DD_ADC_ANA}	ADC analog power supply 5 V
66	V _{DD_ADC_ANA}	ADC analog power supply 5 V
67	V _{DD_ADC_DIG}	ADC digital power supply 5 V
69	V _{DD_ADC_DIG_3.3/5}	ADC 3.3 V power supply for digital output of ADC For interface with 5 V external system: connect to V _{DD_ADC_DIG} For interface with 3.3 V external system: connect to 3.3 V power supply
52 76	V _{DD_PIX}	Pixel array power supply [default: 5 V, the device is then in 'soft reset'. To avoid the image lag associated with soft reset, reduce this voltage to 3...3.5 V 'hard reset']
78	V _{DD_DIG}	Digital power supply 5 V
79	V _{DD_RESL}	Reset power supply 5 V

Table 8. GROUND CONNECTIONS

Pin	Pin Name	Pin Description
9	GND_ANA	Analog ground
12	GND_DIG	Digital ground
30	GND_AMP	Ground of output amplifier
32	GND_DIG	Digital ground
35	GND_ANA	Analog ground
51	GND_DIG	Digital ground
54	GND_ADC_ANA	ADC analog ground
65	GND_ADC_ANA	ADC analog ground
68	GND_ADC_DIG	ADC digital ground
77	GND_DIG	Digital ground

Table 9. DIGITAL INPUT SIGNALS

Pin	Pin Name	Pin Description
1	S	Control signal for column amplifier Apply pulse pattern; see Figure 11.
2	R	Control signal for column amplifier Apply pulse pattern; see Figure 11.
3	RESET	Resets row indicated by left/right shift register high active (1= reset row) Apply pulse pattern; see Figure 11.
4	SELECT	Selects row indicated by left/right shift register high active (1=select row) Apply 5 V DC for normal operation

NOIS1SM0250A

Table 9. DIGITAL INPUT SIGNALS

Pin	Pin Name	Pin Description
5	L/R	Use left or right shift register for SELECT and RESET 1 = left / 0 = right; see Figure 11.
6	A0	Start address for X and Y pointers (LSB)
7	A1	Start address for X and Y pointers
8	A2	Start address for X and Y pointers
13	A3	Start address for X and Y pointers
14	A4	Start address for X and Y pointers
15	A5	Start address for X and Y pointers
16	A6	Start address for X and Y pointers
17	A7	Start address for X and Y pointers
18	A8	Start address for X and Y pointers (MSB)
19	LD_Y	Latch address (A0...A8) to Y start register (0 = track, 1 = hold)
20	LD_X	Latch address (A0...A8) to X start register (0 = track, 1 = hold)
21	CLK_YL	Clock YL shift register (shifts on falling edge)
22	SYNC_YL	Sets YL shift register to location preloaded in Y start register Low active (0=sync) Apply SYNC_YL when CLK_YL is high
24	CLK_X	Clock X shift register (output valid and s when CLK_X is low)
25	SYNC_X	Sets X shift register to location preloaded in X start register Low active (0=sync) Apply SYNC_X when CLK_X is high After SYNC_X, apply falling edge on CLK_X, and rising edge on CLK_X
27	CLK_YR	Clock YR shift register (shifts on falling edge)
28	SYNC_YR	Sets YR shift register to location preloaded in Y start register Low active (0=sync) Apply SYNC_YR when CLK_YR is high
36	CAL	Initialize output amplifier Output amplifier will output BLACKREF in unity gain mode when CAL is high (1) Apply pulse pattern (one pulse per frame); see Figure 11.
37	G0	Select output amplifier gain value: G0 = LSB; G1 = MSB 00 = unity gain; 01 = x2; 10 = x4; 11 = x8
38	G1	idem
71	CLK_ADC	ADC clock ADC converts on falling edge
75	BITINVERT	1 = invert output bits 0 = no inversion of output bits
80	TRI_ADC	Tristate control of digital ADC outputs 1 = tristate; 0 = output

NOIS1SM0250A

Table 10. DIGITAL OUTPUT SIGNALS

Pin	Pin Name	Pin Description
23	EOS_YL	End-of-scan of YL shift register Low first clock period after last row (low active)
26	EOS_X	End-of-scan of X shift register Low first clock period after last active column (low active)
29	EOS_YR	End-of-scan of YR shift register Low first clock period after last row (low active)
55	D0	ADC output bit (LSB)
56	D1	ADC output bit
57	D2	ADC output bit
58	D3	ADC output bit
59	D4	ADC output bit
60	D5	ADC output bit
61	D6	ADC output bit
62	D7	ADC output bit
63	D8	ADC output bit
64	D9	ADC output bit (MSB)

Table 11. ANALOG INPUT SIGNALS

Pin	Pin Name	Pin Description
39	NBIASARR	Connect with 470 k to V_{DD} and decouple to ground with a 100 nF capacitor.
40	PBIAS	Connect with 39 k to ground and decouple to V_{DD} with a 100 nF capacitor for 8 MHz pixel rate. (Lower resistor values yield higher maximal pixel rates at the cost of extra power dissipation).
41	NBIAS_AMP	Output amplifier speed/power control. Connect with 51 k Ω to V_{DD} and decouple with 100 nF to GND for 8 MHz output rate (Lower resistor values yield higher maximal pixel rates at the cost of extra power dissipation).
42	BLACKREF	Control voltage for output signal offset level. Buffered on-chip, the reference level can be generated by a 100 k Ω resistive divider. Connect to ± 2 V DC for use with on-chip ADC.
44	IN_ADC	Input, connect to sensor output. Input range is between 2 and 4 V (V_{LOW_ADC} and V_{HIGH_ADC}).
45	NBIASANA2	Connect with 100 k to V_{DD} and decouple to GND.
46	NBIASANA	Connect with 100 k to V_{DD} and decouple to GND.
47 70	V_{LOW_ADC} V_{HIGH_ADC}	Low reference and high reference voltages of ADC should be about 2 V and 4 V. The required voltage settings on V_{LOW_ADC} and V_{HIGH_ADC} can be approximated by tying V_{LOW_ADC} with 1.2 k Ω to GND and V_{HIGH_ADC} with 560 Ω to V_{DD} .
48	G_AB	Antiblooming drain control voltage: Default: connect to ground. The antiblooming is operational but not maximal. Apply 1 V DC for improved antiblooming.
72	PBIASDIG2	Connect with 100 K to GND and decouple to V_{DD} .
73	PBIASENCLOAD	Connect with 100 K to GND and decouple to V_{DD} .
74	PBIASDIG1	Connect with 47 K to GND and decouple to V_{DD} .

Table 12. ANALOG OUTPUT SIGNALS

Pin	Pin Name	Pin Description
43	OUT	Analog output signal are connected to the analog input of the ADC.

NOIS1SM0250A

Table 13. TEST STRUCTURES

Pin	Pin Name	Pin Description
81	TESTDIODE	Plain photo diode, size: 14 x 25 pixels. Must be left open for normal operation.
82	TESTPIX ARRAY	Array of test pixels, connected in parallel (14 x 25 pixels). Must be left open for normal operation.
83	TESTPIXEL_RESET	Reset input of single test pixel. Must be tied to GND for normal operation.
84	TESTPIXEL_OUT	Output of single test pixel. Must be left open for normal operation.

Glass Lid Specifications

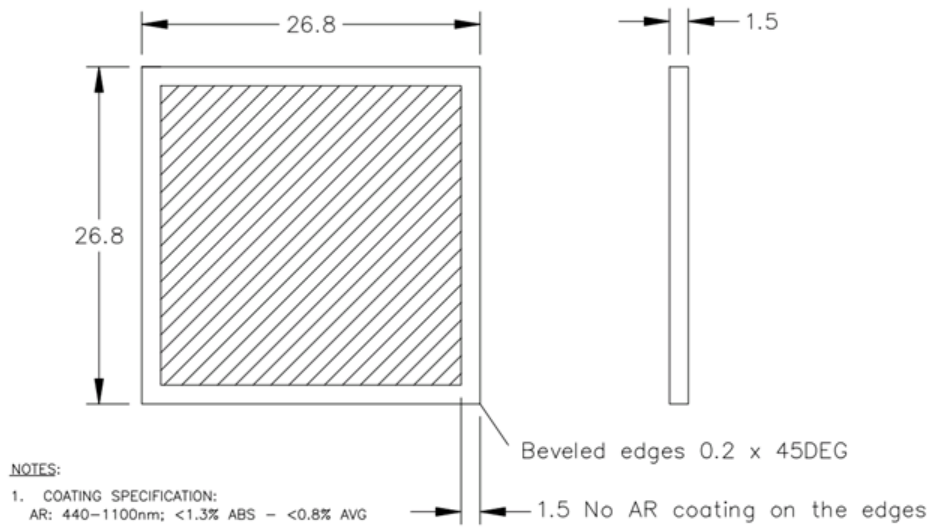
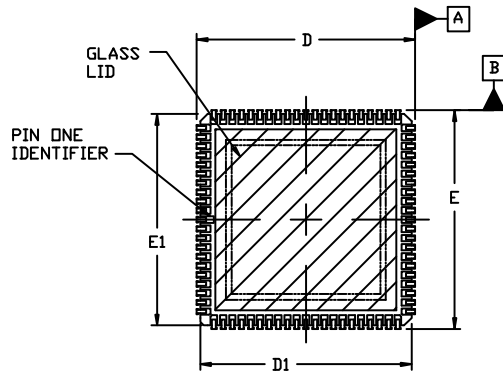

Figure 13. Geometrical Characteristics (in mm)

NOIS1SM0250A

PACKAGE DIMENSIONS

JLDCC84
CASE 114AK
ISSUE A



TOP VIEW

NOTES:

1. DIMENSIONING AND TOLERANCING PER ASME Y14.5M, 1994.
2. CONTROLLING DIMENSION: MILLIMETERS
3. DATUMS A, B, AND D ARE DETERMINED AT DATUM C. POSITION OF THE LEADS IS DETERMINED AT DATUM C.
4. COPLANARITY APPLIES TO THE LOWEST PART OF THE LEAD.

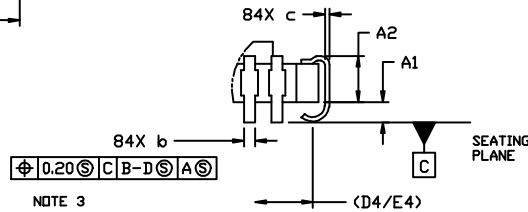

DETAIL A

DIM	MILLIMETERS	
	MIN.	MAX.
A	3.77	4.57
A1	0.51	---
A2	2.16	REF
b	0.46	0.56
c	---	0.20
D	30.08	30.38
D1	28.96	29.46
D4	28.70	BSC
E	30.08	30.38
E1	28.96	29.46
E4	28.70	BSC
e	1.27	BSC
h	0.90	1.15

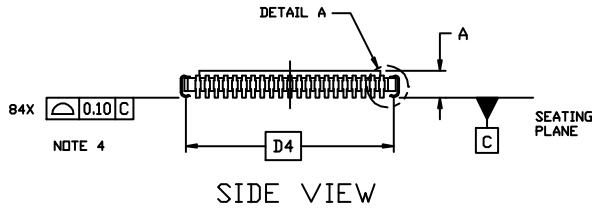

SIDE VIEW

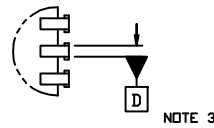

DETAIL B

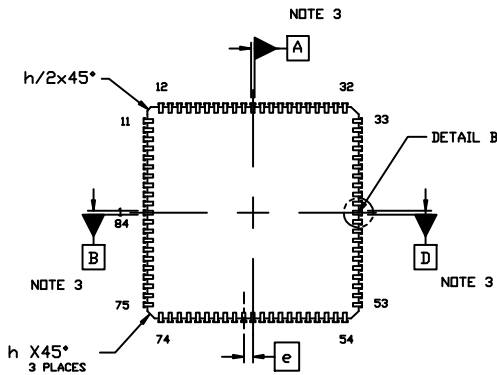

BOTTOM VIEW

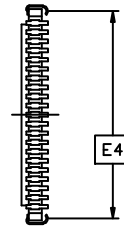

END VIEW

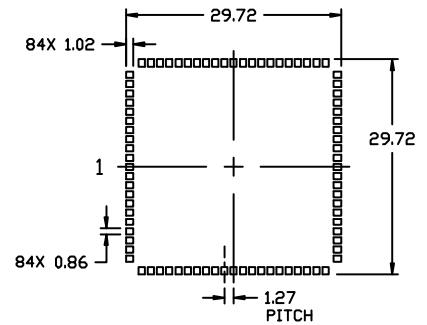

RECOMMENDED MOUNTING FOOTPRINT

Table 14. PACKAGE SPECIFICATIONS

Type	JLCC-84
Material	Black Alumina BA-914
Thermal expansion coefficient	$7.6 \times 10^{-6} /K$

Table 15. MECHANICAL SPECIFICATIONS

Characteristics	Limits			Units
	Min	Typ	Max	
Package tolerance	–	–	0.15	mm
Die position, X offset	–0.05	0	0.05	mm
Die position, Y offset	–0.018	–	0.118	mm
Die position, planarity	–0.05	0	0.05	mm
Die position, Y tilt	–0.05	0	0.05	mm

NOTE: Min and Max limits are not measured on every unit, but guaranteed by assembly process.

Die Alignment

The die is aligned manually in the package to a tolerance of $\pm 50 \mu\text{m}$ and the alignment is verified after hardening the die adhesive. All dimensions in Figure 14 are in mm.

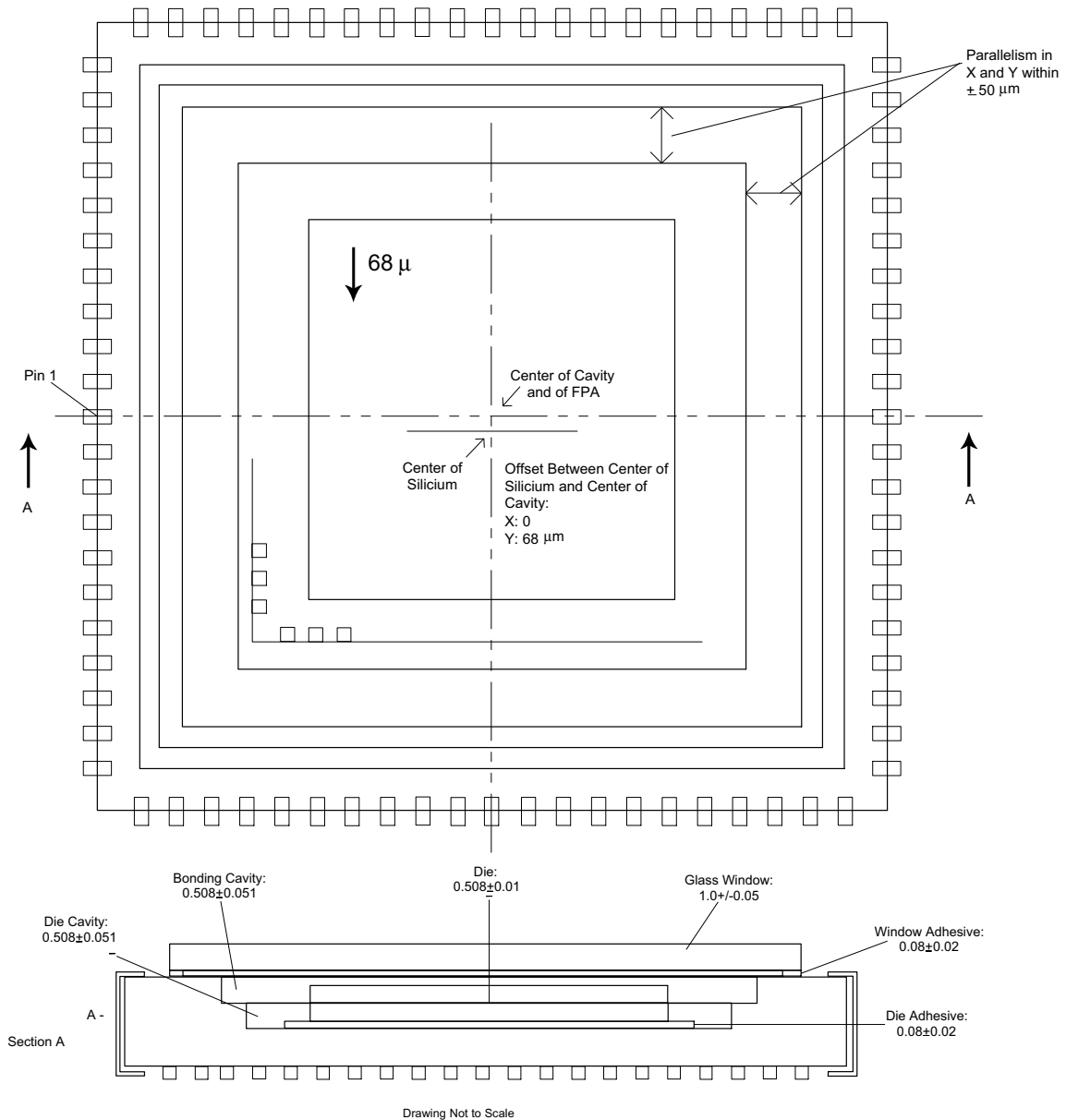

Figure 14. Die Alignment

SOLDERING AND HANDLING

HANDLING PRECAUTIONS

For proper handling and storage conditions, refer to the ON Semiconductor application note AN52561.

Limited Warranty

ON Semiconductor Image Sensor Business Unit warrants that the image sensor products mentioned here, if properly used and serviced, conform to the seller’s published specifications. They are free from defects in material and workmanship for two (2) years following the date of shipment.

RoHS (Pb-free) Compliance

This section reports the use of hazardous chemical substances as required by the RoHS Directive (excluding packing material).

Table 16. CHEMICAL SUBSTANCES IN STAR250 SENSOR

Chemical Substance	Any Intentional Content	If there is any intentional content, in which portion is it contained?
Lead	No	–
Cadmium	No	–
Mercury	No	–
Hexavalent chromium	No	–
PBB (Polybrominated biphenyls)	No	–
PBDE (Polybrominated diphenyl ethers)	No	–

Information on Pb-free Soldering

The product cannot withstand a Pb-free soldering process. Reflow or wave soldering is not allowed; hand soldering only. Solder one pin on each side of the sensor and allow it to cool for at least one minute before continuing.

NOTE: “Intentional content” is defined as any material demanding special attention that is contained in the inquired product by the following cases:

1. A case that the above material is added as a chemical composition into the inquired product intentionally to produce and maintain the required performance and function of the intended product.

2. A case that the above material, which is used intentionally in the manufacturing process, is contained in or adhered to the inquired product.

The following case is not treated as “intentional content”:

A case that the above material is contained as an impurity into raw materials or parts of the intended product. The impurity is defined as a substance that cannot be removed industrially, or it is produced at a process such as chemical composing or reaction and it cannot be removed technically.

ACCEPTANCE CRITERIA SPECIFICATION

The Product Acceptance Criteria is available on request. This document contains the criteria to which the STAR250 is tested before being shipped.

NOIS1SM0250A

ACRONYMS

Acronym	Definition
ADC	analog to digital convertor
CIS	CMOS image sensor
CMOS	complementary metal oxide semiconductor
CY	Cypress
DC	dark current
DNL	differential nonlinearity
DS	double sampling
DSNU	dark signal nonuniformity
ESD	electrostatic discharge
FF	fill factor
FPN	fixed pattern noise
FPS	frames per second
FS	frame start
fs	full scale
I/O	input/output
IMG	image
INL	integral nonlinearity
IP	intellectual property
LDO	low drop-out
LSB	least significant bit
LVDS	low voltage differential signaling
MBS	mixed boundary scan

Acronym	Definition
MBPS	megabit per second
MCIS	multifield point CMOS image sensor
MFF	metal fill factor
MIM	metal-insulator-metal
MP	megapixel
Mrad	megaradiation
MSB	most significant bit
MSPS	megasamples per second
MTF	modulation transfer function
MUX	multiplexer
PCB	printed circuit board
PLL	phase-locked loop
PLS	parasitic light sensitivity
PRBS	pseudo random bit stream
PRNU	photo response nonuniformity
PSN	photon shot noise
PSNL	pixel storage node leakage
QC	quantum conversion
QE	quantum efficiency
QFW	pixel full-well charge
RMS	root mean square
ROI	region of interest

NOIS1SM0250A

GLOSSARY

conversion gain	A constant that converts the number of electrons collected by a pixel into the voltage swing of the pixel. Conversion gain = q/C where q is the charge of an electron ($1.602E-19$ Coulomb) and C is the capacitance of the photodiode or sense node.
DNL	Differential nonlinearity (for ADCs)
DSNU	Dark signal nonuniformity. This parameter characterizes the degree of nonuniformity in dark leakage currents, which can be a major source of fixed pattern noise.
fill-factor	A parameter that characterizes the optically active percentage of a pixel. In theory, it is the ratio of the actual QE of a pixel divided by the QE of a photodiode of equal area. In practice, it is never measured.
INL	Integral nonlinearity (for ADCs)
IR	Infrared. IR light has wavelengths in the approximate range 750 nm to 1 mm.
Lux	Photometric unit of luminance (at 550 nm, $1\text{ lux} = 1\text{ lumen/m}^2 = 1/683\text{ W/m}^2$)
pixel noise	Variation of pixel signals within a region of interest (ROI). The ROI typically is a rectangular portion of the pixel array and may be limited to a single color plane.
photometric units	Units for light measurement that take into account human physiology.
PLS	Parasitic light sensitivity. Parasitic discharge of sampled information in pixels that have storage nodes.
PRNU	Photo-response nonuniformity. This parameter characterizes the spread in response of pixels, which is a source of FPN under illumination.
QE	Quantum efficiency. This parameter characterizes the effectiveness of a pixel in capturing photons and converting them into electrons. It is photon wavelength and pixel color dependent.
read noise	Noise associated with all circuitry that measures and converts the voltage on a sense node or photodiode into an output signal.
reset	The process by which a pixel photodiode or sense node is cleared of electrons. "Soft" reset occurs when the reset transistor is operated below the threshold. "Hard" reset occurs when the reset transistor is operated above threshold.
reset noise	Noise due to variation in the reset level of a pixel. In 3T pixel designs, this noise has a component (in units of volts) proportionality constant depending on how the pixel is reset (such as hard and soft). In 4T pixel designs, reset noise can be removed with CDS.
responsivity	The standard measure of photodiode performance (regardless of whether it is in an imager or not). Units are typically A/W and are dependent on the incident light wavelength. Note that responsivity and sensitivity are used interchangeably in image sensor characterization literature so it is best to check the units.
ROI	Region of interest. The area within a pixel array chosen to characterize noise, signal, crosstalk, and so on. The ROI can be the entire array or a small subsection; it can be confined to a single color plane.
sense node	In 4T pixel designs, a capacitor used to convert charge into voltage. In 3T pixel designs it is the photodiode itself.
sensitivity	A measure of pixel performance that characterizes the rise of the photodiode or sense node signal in Volts upon illumination with light. Units are typically $V/(W/m^2)/\text{sec}$ and are dependent on the incident light wavelength. Sensitivity measurements are often taken with 550 nm incident light. At this wavelength, 1 683 lux is equal to 1 W/m^2 ; the units of sensitivity are quoted in $V/\text{lux}/\text{sec}$. Note that responsivity and sensitivity are used interchangeably in image sensor characterization literature so it is best to check the units.
spectral response	The photon wavelength dependence of sensitivity or responsivity.
SNR	Signal-to-noise ratio. This number characterizes the ratio of the fundamental signal to the noise spectrum up to half the Nyquist frequency.
temporal noise	Noise that varies from frame to frame. In a video stream, temporal noise is visible as twinkling pixels.

ON Semiconductor and  are registered trademarks of Semiconductor Components Industries, LLC (SCILLC). SCILLC owns the rights to a number of patents, trademarks, copyrights, trade secrets, and other intellectual property. A listing of SCILLC's product/patent coverage may be accessed at www.onsemi.com/site/pdf/Patent-Marking.pdf. SCILLC reserves the right to make changes without further notice to any products herein. SCILLC makes no warranty, representation or guarantee regarding the suitability of its products for any particular purpose, nor does SCILLC assume any liability arising out of the application or use of any product or circuit, and specifically disclaims any and all liability, including without limitation special, consequential or incidental damages. "Typical" parameters which may be provided in SCILLC data sheets and/or specifications can and do vary in different applications and actual performance may vary over time. All operating parameters, including "Typicals" must be validated for each customer application by customer's technical experts. SCILLC does not convey any license under its patent rights nor the rights of others. SCILLC products are not designed, intended, or authorized for use as components in systems intended for surgical implant into the body, or other applications intended to support or sustain life, or for any other application in which the failure of the SCILLC product could create a situation where personal injury or death may occur. Should Buyer purchase or use SCILLC products for any such unintended or unauthorized application, Buyer shall indemnify and hold SCILLC and its officers, employees, subsidiaries, affiliates, and distributors harmless against all claims, costs, damages, and expenses, and reasonable attorney fees arising out of, directly or indirectly, any claim of personal injury or death associated with such unintended or unauthorized use, even if such claim alleges that SCILLC was negligent regarding the design or manufacture of the part. SCILLC is an Equal Opportunity/Affirmative Action Employer. This literature is subject to all applicable copyright laws and is not for resale in any manner.

PUBLICATION ORDERING INFORMATION

LITERATURE FULFILLMENT:

Literature Distribution Center for ON Semiconductor
P.O. Box 5163, Denver, Colorado 80217 USA
Phone: 303-675-2175 or 800-344-3860 Toll Free USA/Canada
Fax: 303-675-2176 or 800-344-3867 Toll Free USA/Canada
Email: orderlit@onsemi.com

N. American Technical Support: 800-282-9855 Toll Free
USA/Canada
Europe, Middle East and Africa Technical Support:
Phone: 421 33 790 2910
Japan Customer Focus Center
Phone: 81-3-5817-1050

ON Semiconductor Website: www.onsemi.com
Order Literature: <http://www.onsemi.com/orderlit>
For additional information, please contact your local
Sales Representative