



## RCR6C

Preliminary

CMOS IC

### REMOTE CONTROLLER WITH SEVEN FUNCTIONS

#### DESCRIPTION

The UTC **RCR6C** is a CMOS LSI and designed as receiver that complement to UTC RCT6 for remote controlled car applications. It provide seven control keys controlling the motions, which are forward, backward, rightward, leftward, two function keys, and the turbo function, of the remote controlled car.

UTC **RCR6C** have Forward (Backward) combined with the turbo application. During normal operation without Turbo, Forward (Backward) output from UTC RCT6 sends a 60Hz signal. When Forward (Backward) and Turbo are both in effect, the output signal becomes completely high.

#### FEATURES

- \* Operating voltage range: 2.4V~4.5V
- \* RCR6C-A built-in 3.6V ZENER  
RCR6C-B built-in 4.2V ZENER  
RCR6C-C built-in 5.0V ZENER
- \* Few external components needed
- \* 7-function remote controller controlling Forward/ Backward/ Turbo/ Right-turn/ Left turn/ two function keys
- \* Complement to UTC RCT6.

#### ORDERING INFORMATION

| Order Number   |                | Package | Packing |
|----------------|----------------|---------|---------|
| Lead Free      | Halogen Free   |         |         |
| -              | RCR6CG-x-D18-T | DIP-18  | Tube    |
| RCR6CL-x-D20-T | RCR6CG-x-D20-T | DIP-20  | Tube    |

|   |   |
|---|---|
| <p>RCR6CG-x-D18-T</p> <ul style="list-style-type: none"> <li>(1) Packing Type</li> <li>(2) Package Type</li> <li>(3) Rank</li> <li>(4) Green Package</li> </ul> | <ul style="list-style-type: none"> <li>(1) T: Tube</li> <li>(2) D18: DIP-18, D20: DIP-20</li> <li>(3) x: refer to I<sub>OPR</sub></li> <li>(4) G: Halogen Free and Lead Free, L: Lead Free</li> </ul> |
|---|---|

#### MARKING

| DIP-18 | DIP-20 |
|--------|--------|
|        |        |

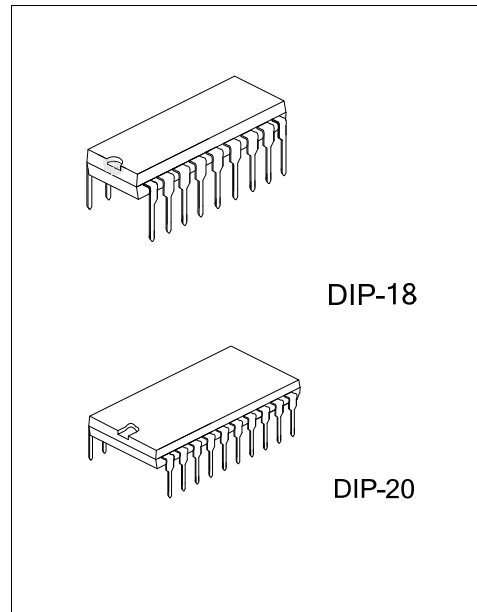

■ PIN CONFIGURATIONS

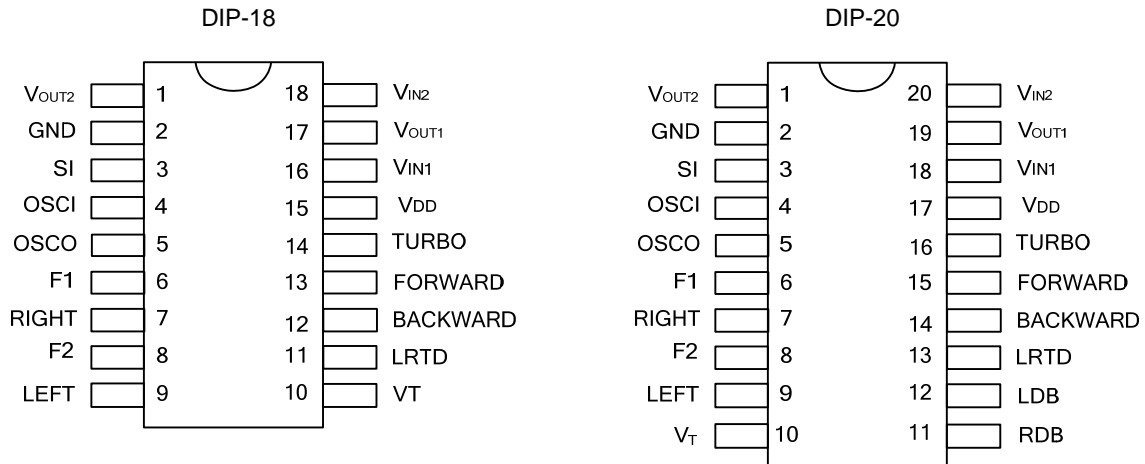

■ PIN DESCRIPTION

| PIN NO. |        | PIN NAME          | DESCRIPTION  |
|---------|--------|-------------------|--|
| DIP-18  | DIP-20 |                   |  |
| 1       | 1      | V <sub>OUT2</sub> | Inverter 2 output pin for power amplify  |
| 2       | 2      | GND               | Negative power supply  |
| 3       | 3      | SI                | Input pin of the encoding signal   |
| 4       | 4      | OSCI              | Oscillator input pin   |
| 5       | 5      | OSCO              | Oscillator output pin  |
| 6       | 6      | F1                | F1 function output pin   |
| 7       | 7      | RIGHT             | Rightward output pin   |
| 8       | 8      | F2                | F2 function output pin   |
| 9       | 9      | LEFT              | Leftward output pin  |
| 10      | 10     | V <sub>T</sub>    | Auto Shut-OFF input pin<br>If V <sub>T</sub> voltage exceeds 1.4V, all outputs shut off automatically. |
|         | 11     | RDB               | With Pull-up resistor, rightward function disabled if this pin connected to GND                        |
|         | 12     | LDB               | With Pull-up resistor, leftward function disabled if this pin connected to GND                         |
| 11      | 13     | LRTD              | If connect gnd ,Left/right+ turbo is disable   |
| 12      | 14     | BACKWARD          | Backward output pin  |
| 13      | 15     | FORWARD           | Forward output pin   |
| 14      | 16     | TURBO             | TURBO output pin   |
| 15      | 17     | V <sub>DD</sub>   | Positive power supply  |
| 16      | 18     | V <sub>IN1</sub>  | Inverter 1 input pin for signal amplify  |
| 17      | 19     | V <sub>OUT1</sub> | Inverter 1 output pin for signal amplify   |
| 18      | 20     | V <sub>IN2</sub>  | Inverter 2 input pin for signal amplify  |

■ BLOCK DIAGRAM

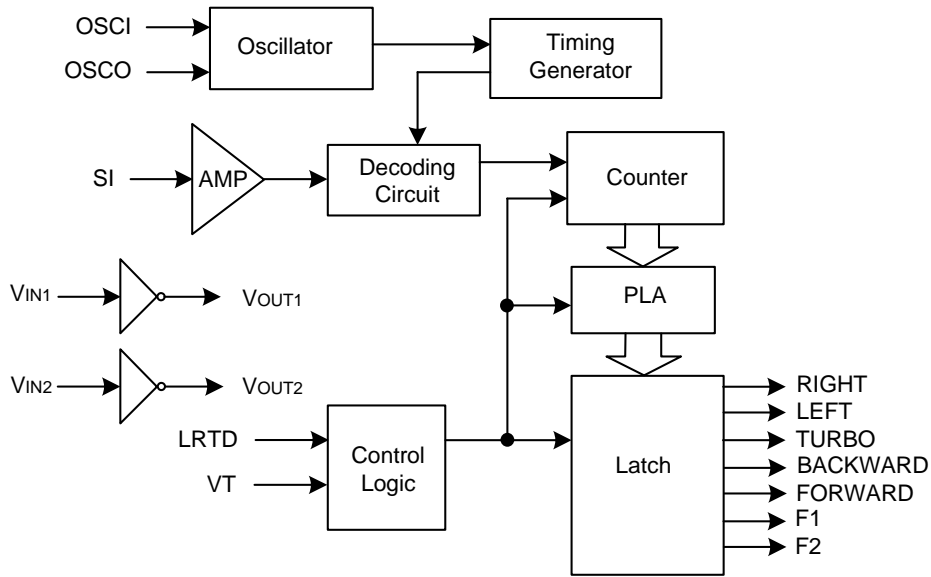

| Input Condition  | O/P Condition |          |       |
|------------------|---------------|----------|-------|
|                  | Forward       | Backward | Turbo |
| Forward          | =60Hz         | Low      | Low   |
| Backward         | Low           | =60Hz    | Low   |
| Forward + turbo  | =high         | Low      | =high |
| Backward + turbo | Low           | =high    | =high |

Note: An Auto Shut-Off mechanism is built-in according to Toy Safety Requirement and effective during over-current situation in motor driver. The active high input applying to this Auto Shut-Off pin will turn off the motor. (V<sub>T</sub> pin, when unused, has to be connected to ground. The transfer point =1.4V)

■ ABSOLUTE MAXIMUM RATINGS

| PARAMETER             | SYMBOL    | RATINGS               | UNIT |
|-----------------------|-----------|-----------------------|------|
| DC Supply Voltage     | $V_{DD}$  | 2.4~4.5               | V    |
| Input/Output Voltage  |           | GND-0.2~ $V_{DD}+0.2$ | V    |
| Operating Temperature | $T_{OPR}$ | -10~+60               | °C   |
| Storage Temperature   | $T_{STG}$ | -25~+125              | °C   |

Note: Absolute maximum ratings are those values beyond which the device could be permanently damaged. Absolute maximum ratings are stress ratings only and functional device operation is not implied.

■ ELECTRICAL CHARACTERISTICS ( $T_A=25^{\circ}\text{C}$ ,  $V_{DD}=3.5\text{V}$ ,  $F_{OSC}=128\text{KHz}$ , unless otherwise specified.)

Direct Driving: No connect a resistance between POWER and IC's  $V_{DD}$  pin.

| PARAMETER                             | SYMBOL          | TEST CONDITIONS      | MIN     | TYP | MAX | UNIT |
|---------------------------------------|-----------------|----------------------|---------|-----|-----|------|
| Operating Voltage                     | $V_{OPR}$       |                      | 2.4     |     | 4.5 | V    |
| Supply Current                        | $I_{DD}$        | Unload               | RCR6C-A |     | 15  | mA   |
|                                       |                 |                      | RCR6C-B |     | 0.6 |      |
|                                       |                 |                      | RCR6C-C |     | 0.5 |      |
| O/P Driving Current                   | $I_{DRIVE}$     | $V_{OH}=0.7\text{V}$ | 5.0     |     |     | mA   |
| O/P Driving Current (F1, F2)          | $I_{DRIVE}$     | $V_{OH}=0.7\text{V}$ | 5.0     |     |     | mA   |
| Effect Decoding (Frequency Variation) | $F_{TOLERANCE}$ |                      | -50     |     | 50  | %    |
| Oscillator Frequency                  | $F_{OSC}$       |                      |         | 128 |     | KHz  |
| Oscillator Frequency Tolerance        | Ftolerance      | UTC RCT6 FOSC=128KHz | -20     |     | +20 | %    |

■ DATA FORMAT

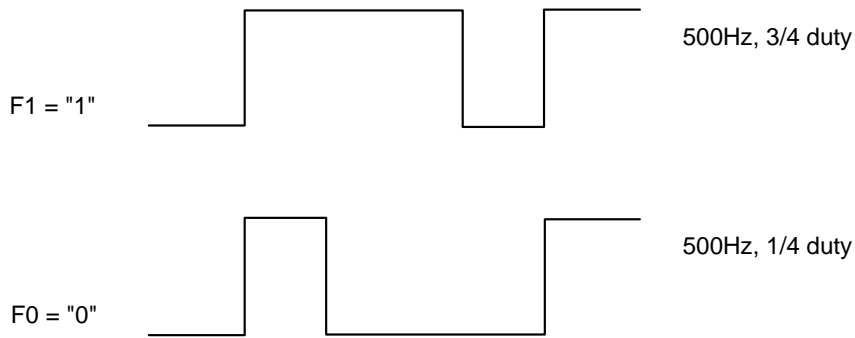

■ CODING METHOD

The data string that UTC **RCR6C** receiver is below:

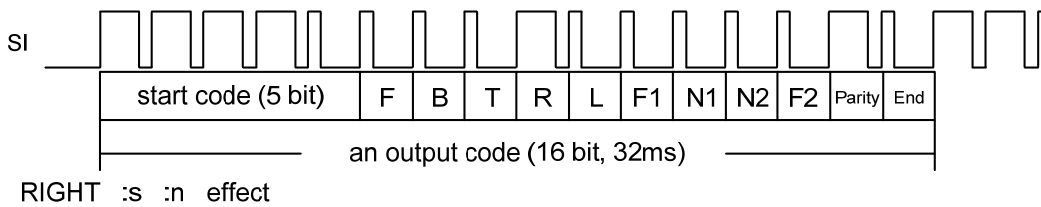

Data string: start code + data code + parity code + end code

- start code = F1 F1 F1 F1 F0

- data code = 

|   |   |   |   |   |    |   |   |    |
|---|---|---|---|---|----|---|---|----|
| F | B | T | R | L | F1 | N | N | F2 |
|---|---|---|---|---|----|---|---|----|

F = Forward      B = Backward      T = Turbo  
 R = Right      L = Left      F1 = Function 1  
 F2 = Function 2      N = No used code

F、B、T、R、L、F1、N、N、F2 all can have two data format, "F1" or "F0",  
 "F1" means the function is in effect, and "F0" means not.

- parity code = for parity check

- end code = for (latch data)

\* Data code can be any combination of F, B, T, R, L, F1, F2, except for F & B, and R & L

■ OUTPUT TABLES

| FUNCTION                 | OUTPUT STATUS |   |   |   |   |    |    |
|--------------------------|---------------|---|---|---|---|----|----|
|                          | F             | B | T | R | L | F1 | F2 |
| FORWARD                  | Z             |   |   |   |   |    |    |
| LEFT+FORWARD             | Z             |   |   |   | H |    |    |
| RIGHT+FORWARD            | Z             |   |   | H |   |    |    |
| TURBO                    |               |   | H |   |   |    |    |
| TURBO+FORWARD            | H             |   | H |   |   |    |    |
| TURBO+LEFT+FORWARD       | H             |   | H |   | H |    |    |
| TURBO+RIGHT+FORWARD      | H             |   | H | H |   |    |    |
| BACKWARD                 |               | Z |   |   |   |    |    |
| BACKWARD+RIGHT           |               | Z |   | H |   |    |    |
| BACKWARD+LEFT            |               | Z |   |   | H |    |    |
| TURBO+BACKWARD           |               | H | H |   |   |    |    |
| TURBO+BACKWARD+RIGHT     |               | H | H | H |   |    |    |
| TURBO+BACKWARD+LEFT      |               | H | H |   | H |    |    |
| LEFT                     |               |   |   |   | H |    |    |
| RIGHT                    |               |   |   | H |   |    |    |
| FUNCTION1                |               |   |   |   |   | H  |    |
| FORWARD+FUNCTION1        | Z             |   |   |   |   | H  |    |
| FORWARD+TURBO+FUNCTION1  | H             |   | H |   |   | H  |    |
| TURBO+FUNCTION1          |               |   | H |   |   | H  |    |
| BACKWARD+FUNCTION1       |               | Z |   |   |   | H  |    |
| BACKWARD+TURBO+FUNCTION1 |               | H | H |   |   | H  |    |
| LEFT+FORWARD+FUNCTION1   | Z             |   |   |   | H | H  |    |
| RIGHT+FORWARD+FUNCTION1  | Z             |   |   | H |   | H  |    |
| LEFT+BACKWARD+FUNCTION1  |               | Z |   |   | H | H  |    |
| RIGHT+BACKWARD+FUNCTION1 |               | Z |   | H |   | H  |    |
| LEFT+FUNCTION1           |               |   |   |   | H | H  |    |
| RIGHT+FUNCTION1          |               |   |   | H |   | H  |    |
| FUNCTION2                |               |   |   |   |   |    | H  |
| FORWARD+FUNCTION2        | Z             |   |   |   |   |    | H  |
| FORWARD+TURBO+FUNCTION2  | H             |   | H |   |   |    | H  |
| TURBO+FUNCTION2          |               |   | H |   |   |    | H  |
| BACKWARD+FUNCTION2       |               | Z |   |   |   |    | H  |
| BACKWARD+TURBO+FUNCTION2 |               | H | H |   |   |    | H  |
| LEFT+FORWARD+FUNCTION2   | Z             |   |   |   | H |    | H  |
| RIGHT+FORWARD+FUNCTION2  | Z             |   |   | H |   |    | H  |
| LEFT+BACKWARD+FUNCTION   |               | Z |   |   | H |    | H  |
| RIGHT+BACKWARD+FUNCTION2 |               | Z |   | H |   |    | H  |
| LEFT+FUNCTION            |               |   |   |   | H |    | H  |
| RIGHT+FUNCTION2          |               |   |   | H |   |    | H  |

H = high level, Z = 60Hz flash, Blank=L

Thus, from the table, we can see that there are more than 50 states of function combinations from 7 control keys.

■ NOTE

(1) LRTD pin functions as an option pin for LEFT/RIGHT turbo disable.

| "LRTD"      | Key selected                   | Output Function                |
|-------------|--------------------------------|--------------------------------|
| HIGH (OPEN) | FORWARD + LEFT (RIGHT) + TURBO | FORWARD + LEFT (RIGHT) + TURBO |
| LOW         | FORWARD + LEFT (RIGHT) + TURBO | FORWARD + LEFT (RIGHT)         |

(2) The UTC **RCR6C** have built in a zener diode, so you must add a resistance between POWER and IC's  $V_{DD}$  pin, like the R6 of UTC **RCR6C** application circuit.

### ■ TYPICAL APPLICATION CIRCUIT (FOR REFERENCE ONLY)

Receiver (UTC **RCR6C DIP-18**  $f_{osc} \cong 128\text{KHz}$ )

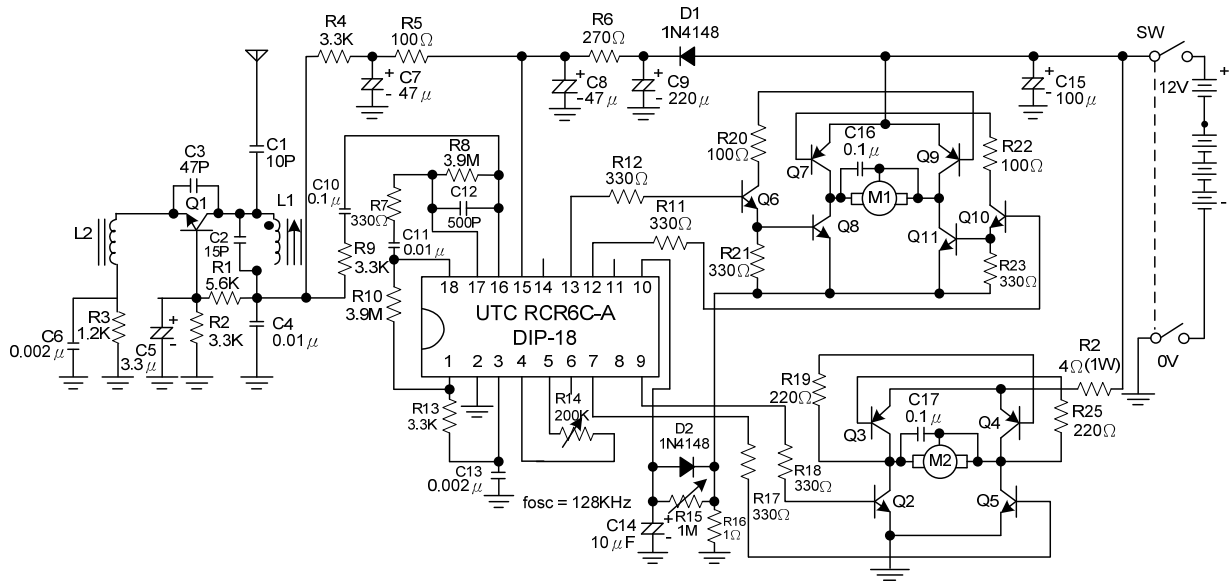

■ TEST CIRCUIT

Fosc for UTC RCR6C  $\cong$  128KHz

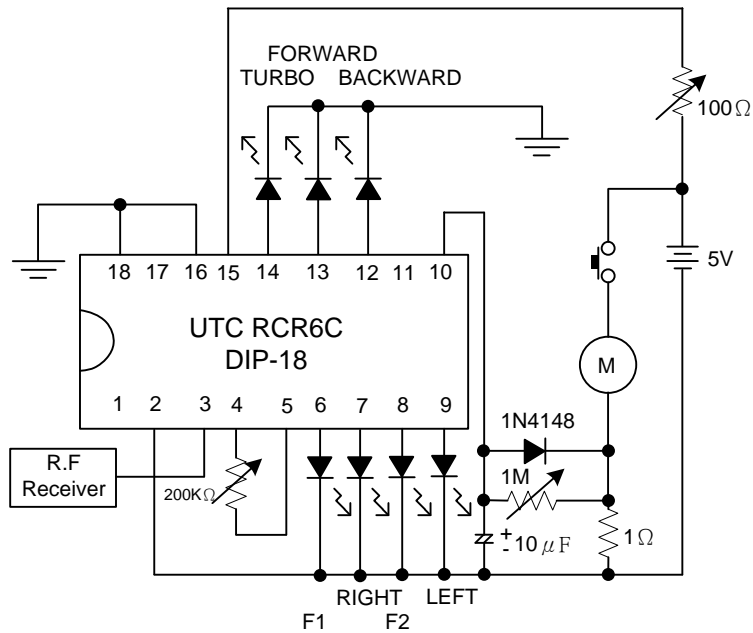

UTC RCT6 output pin (SO) has an inverted phase with UTC RCR6C input (SI). If UTC RCT6 is connected without using a R<sub>F</sub> module, an inverter has to be inserted between this 2 pins.

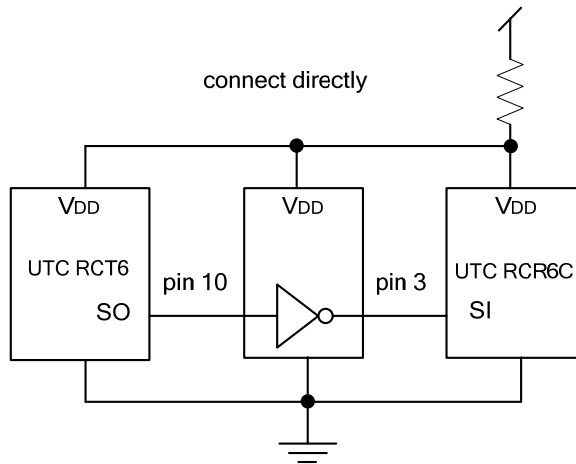

UTC assumes no responsibility for equipment failures that result from using products at values that exceed, even momentarily, rated values (such as maximum ratings, operating condition ranges, or other parameters) listed in products specifications of any and all UTC products described or contained herein. UTC products are not designed for use in life support appliances, devices or systems where malfunction of these products can be reasonably expected to result in personal injury. Reproduction in whole or in part is prohibited without the prior written consent of the copyright owner. The information presented in this document does not form part of any quotation or contract, is believed to be accurate and reliable and may be changed without notice.