

Description

The AL1663/AL1663R is a high performance single stage Flyback and Buck-boost controller, targeting dimmable LED lighting application. It is a primary side regulation (PSR) controller which can provide accurate constant current (CC) regulation without opto-coupler and secondary control circuitry. It is operating at BCM mode which results in good EMI and efficiency, and keeps high PF and low total harmonic distortion (THD) under universal input voltage.

The AL1663/AL1663R can support multiple dimming modes. When a 0.3 to 2.4V DC signal is applied on APWM pin, the device will operate in analog dimming mode. When a digital signal is applied on APWM pin, the device works at PWM dimming mode. And for AL1663 When a digital signal is applied on PWMD pin and the APWM pin is connected with a hundreds of nF capacitor, the device will work in PWM-to-DC dimming mode.

The AL1663/AL1663R features low start-up current and low operation current. It integrates multiple protections including over voltage, short circuit, over current and over temperature protection.

The AL1663/AL1663R is available in SO-8 package.

Features

- Primary Side Regulation without Opto-coupler
- Valley Switching for Low Switching Loss
- Low Start-up Current
- High PF and Low THD
- High Efficiency
- Tight LED Current Variation Range
- Tight Output Open Voltage Variation Range
- Support both PWM Dimming and Analog Dimming
- Internal Protections
 - Under Voltage Lock Out (UVLO)
 - Output Over Voltage Protection (OVP)
 - Output Short Protection (OSP)
 - Over Current Protection (OCP)
 - Thermal Fold-back Protection (TFP)
 - Over Temperature Protection (OTP)
- Low System Cost
- Package: SO-8
- **Totally Lead-Free & Fully RoHS Compliant (Notes 1 & 2)**
- **Halogen and Antimony Free. "Green" Device (Note 3)**

- Notes:
1. No purposely added lead. Fully EU Directive 2002/95/EC (RoHS) & 2011/65/EU (RoHS 2) compliant.
 2. See http://www.diodes.com/quality/lead_free.html for more information about Diodes Incorporated's definitions of Halogen- and Antimony-free, "Green" and Lead-free.
 3. Halogen- and Antimony-free "Green" products are defined as those which contain <900ppm bromine, <900ppm chlorine (<1500ppm total Br + Cl) and <1000ppm antimony compounds.

Pin Assignments

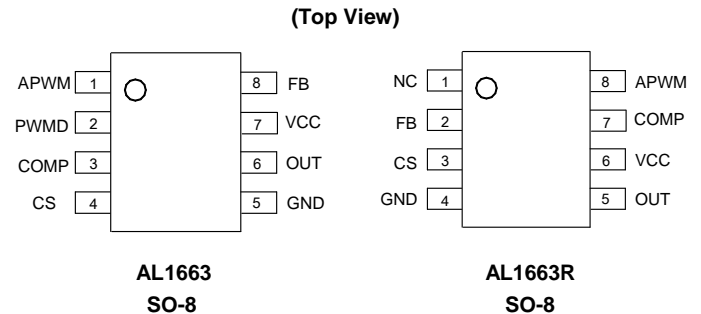

Applications

- General LED Lighting Driver with Dimming Function
- General Purpose Constant Current Source
- LED Backlighting Driver
- Smart LED Lighting

Typical Applications Circuit

NEW PRODUCT

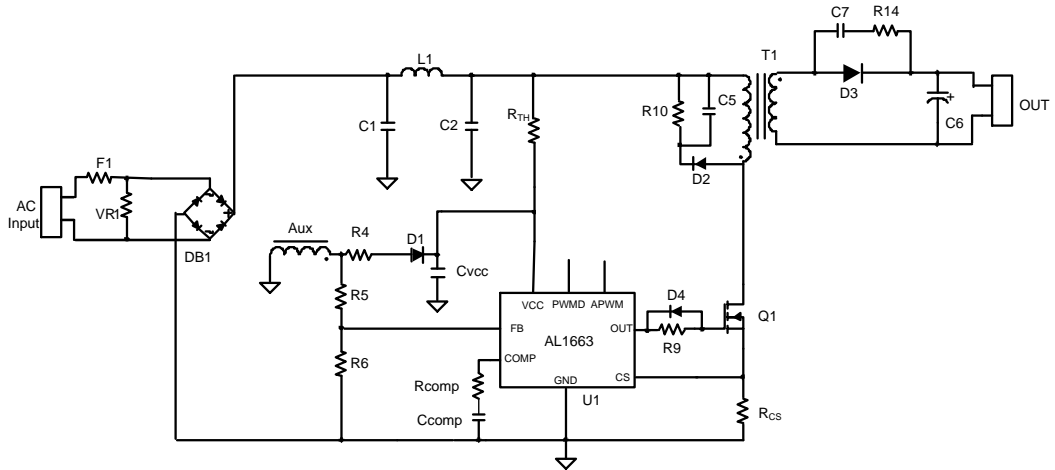

AL1663 Flyback Application Circuit

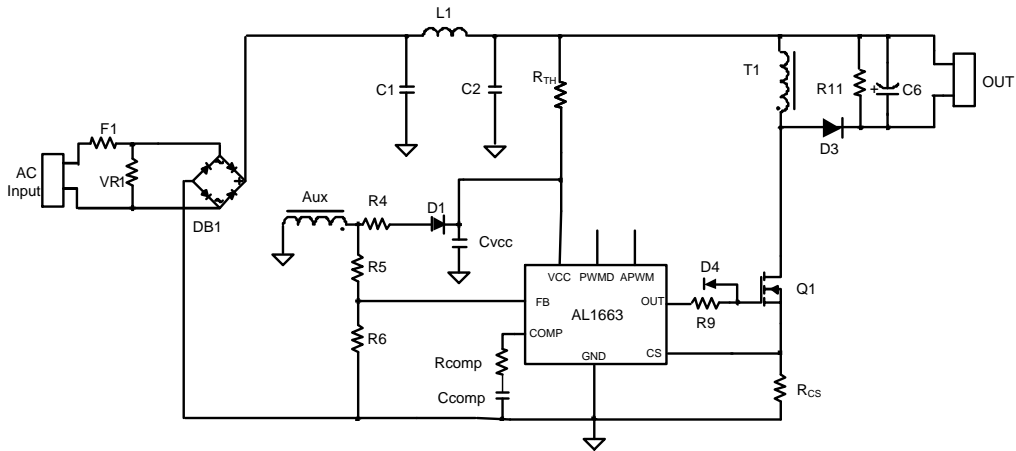

AL1663 Buck-Boost Application Circuit

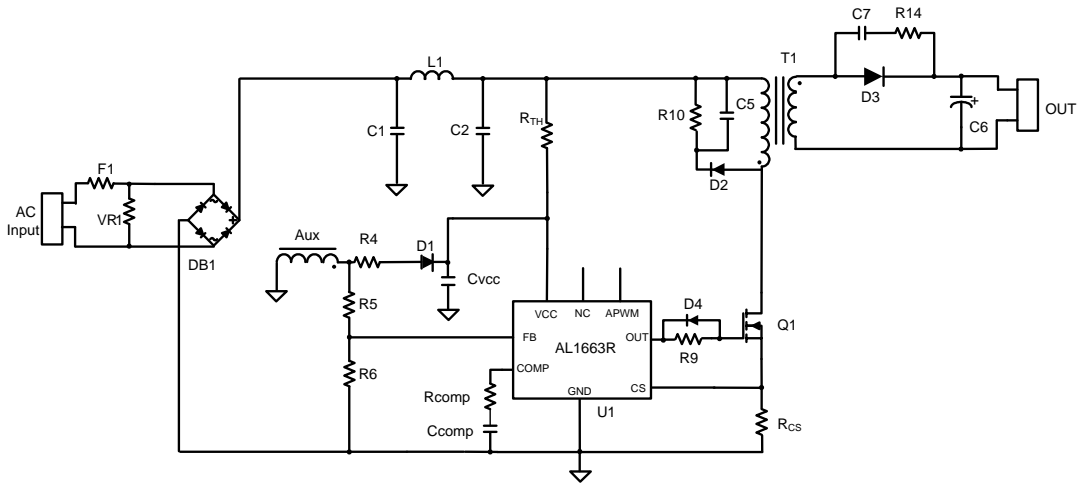

AL1663R Flyback Application Circuit

Pin Descriptions

Pin Number		Pin Name	Function
AL1663	AL1663R		
1	8	APWM	Analog dimming input pin or PWM signal input pin in PWM dimming mode
2	–	PWMD	PWMD signal input pin in PWM-to-DC dimming mode
–	1	NC	Not Connected
3	7	COMP	Loop compensation pin
4	3	CS	Current sense pin, connect this pin to the source of the primary switch
5	4	GND	Ground
6	5	OUT	Gate driver output
7	6	VCC	Supply voltage of gate driver and control circuits of the IC
8	2	FB	The feedback voltage sensing from the auxiliary winding

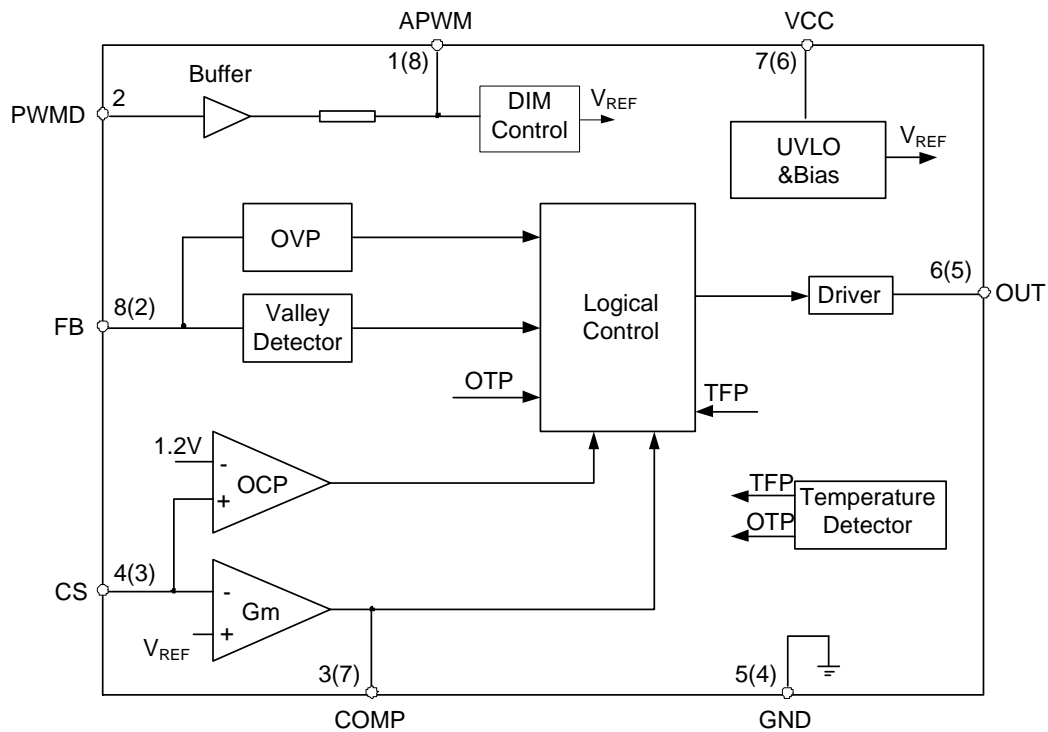
Functional Block Diagram

A(B)
 A for AL1663
 B for AL1663R

Absolute Maximum Ratings (@T_A = +25°C, unless otherwise specified.) (Note 4)

Symbol	Parameter	Rating	Unit
V _{CC}	Power Supply Voltage	-0.3 to 30	V
V _{CS}	Voltage at CS to GND	-0.3 to 7	V
V _{FB}	FB Input	-0.3 to 7	V
V _{COMP}	Loop Compensation Pin	-0.3 to 7	V
V _{OUT}	Driver Output Voltage	-0.3 to 20	V
V _{PWMD}	Voltage at PWMD to GND	-0.3 to 7	V
V _{APWM}	Voltage at APWM to GND	-0.3 to 7	V
T _J	Operating Junction Temperature	-40 to +150	°C
T _{STG}	Storage Temperature	-65 to +150	°C
T _{LEAD}	Lead Temperature (Soldering, 10 sec)	+300	°C
P _D	Power Dissipation at T _A = +50°C	0.65	W
θ _{JA}	Thermal Resistance (Junction to Ambient)	150	°C/W
θ _{JC}	Thermal Resistance (Junction to Case)	23	°C/W
-	ESD (Human Body Model)	2000	V
	CDM (Charged-Device Model)	1000	V

Note: 4. Stresses greater than those listed under "Absolute Maximum Ratings" may cause permanent damage to the device. These are stress ratings only, and functional operation of the device at these or any other conditions beyond those indicated under "Recommended Operating Conditions" is not implied. Exposure to "Absolute Maximum Ratings" for extended periods may affect device reliability. All voltages unless otherwise stated and measured with respect to GND.

Recommended Operating Conditions (@T_A = +25°C, unless otherwise specified.)

Symbol	Parameter	Min	Max	Unit
T _A	Ambient Temperature (Note 5)	-40	+105	°C

Note: 5. The device may operate normally at +125°C ambient temperature under the condition not triggers temperature protection.

Electrical Characteristics (@T_A = +25°C, unless otherwise specified.)

Symbol	Parameter	Conditions	Min	Typ	Max	Units
UVLO Section						
V _{CC_TH}	Startup Threshold Voltage	–	17	18.5	20	V
V _{OPR_MIN}	Minimal Operating Voltage	After Turn On	7	7.8	8.5	V
V _{CC_OVP}	VCC OVP Voltage	–	25	27	29.9	V
Standby Current Section						
I _{ST}	Startup Current	V _{CC} = V _{CC_TH} -0.5V, before start up	–	0.8	–	μA
I _{CC}	Operating Current	FB, CS connect to GND, C _{GATE} = 100pF	–	1	–	mA
I _{CC_OVP}	Shunt Current in OVP Mode	V _{CC} > V _{CC_OVP}	–	5	–	mA
Drive Output Section						
t _R	Output Voltage Rise Time (Note 6)	C _L = 1nF	–	90	–	ns
t _F	Output Voltage Fall Time (Note 6)	C _L = 1nF	–	30	–	ns
V _{OUT_CLAMP}	Output Clamp Voltage	V _{CC} = 20V	13	14	15	V
t _{ON_MIN}	Minimum On Time (Note 6)	–	–	400	–	ns
t _{ON_MAX}	Maximum On Time	–	–	22	–	μs
t _{OFF_MAX}	Maximum Off Time	–	–	35	–	μs
t _{OFF_MIN}	Minimum Off Time	–	–	2	–	μs
f _{MAX}	Maximum Frequency	–	–	150	–	KHz
Internal CS reference						
V _{REF}	Internal Reference Voltage	–	0.291	0.3	0.309	V
V _{CS_OCP}	Primary Current Clamp Voltage	–	–	1.2	–	V
Error Amplifier						
G _m	Trans-Conductance	–	–	16.7	–	μA/V
I _{SOURCE}	Amplifier Source Current	–	–	10	–	μA
Feedback Input Section						
V _{FB_CV}	FB CV Threshold	–	1.4	1.5	1.6	V
APWM Section						
V _{APWM_L}	PWM Signal Low Threshold Voltage	–	–	–	0.3	V
V _{APWM_H}	PWM Signal High Threshold Voltage	–	2.4	–	–	V
–	Linear Dimming Range on APWM	–	0.3	–	2.4	V
PWMD Section						
V _{PWM_L}	PWM Signal Low Threshold Voltage	–	–	–	0.4	V
V _{PWM_H}	PWM Signal High Threshold Voltage	–	2	–	–	V
Thermal Fold-back Section						
T _{REG}	Overheating Temperature Regulation (Note 6)	–	–	+145	–	°C
Over Temperature Protection Section						
–	Shutdown Temperature (Notes 6, 7)	–	–	+165	–	°C

Notes: 6. These parameters, although guaranteed by design, are not 100% tested in production.

7. The device will latch when OTP happens and the device won't operate constantly at this temperature.

Performance Characteristics (Note 8)

NEW PRODUCT

Startup Threshold Voltage vs. Ambient Temperature

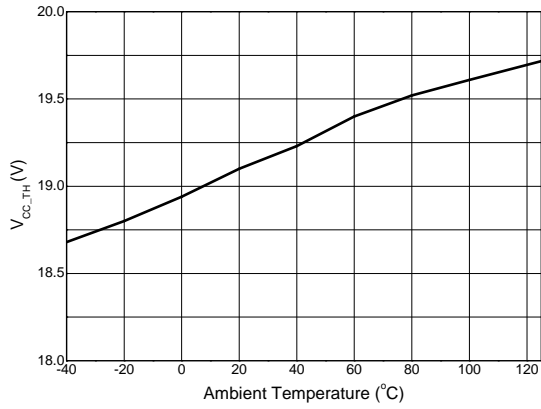

Minimum Operating Voltage vs. Ambient Temperature

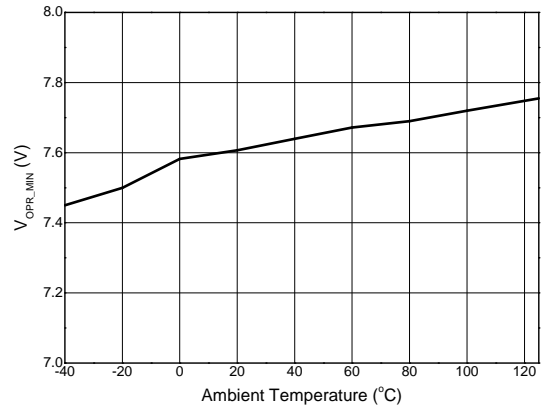

Operating Current vs. Ambient Temperature

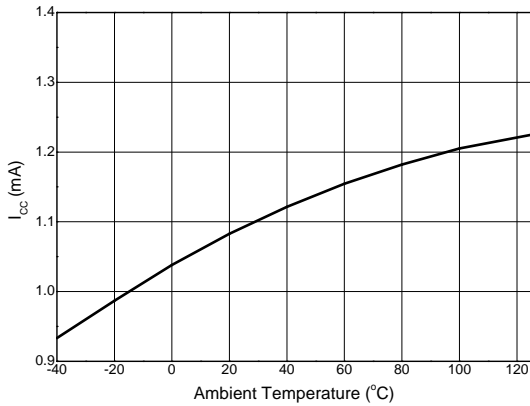

FB CV Threshold vs. Ambient Temperature

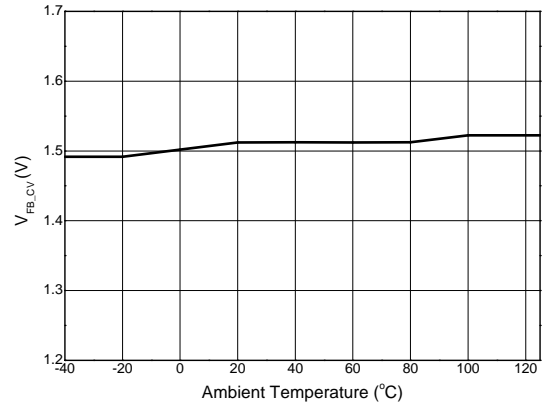

Internal Reference Voltage vs. Ambient Temperature

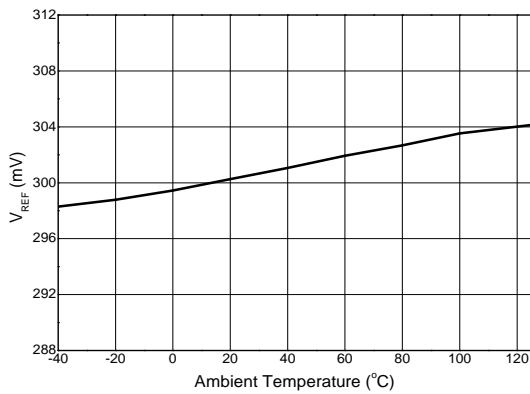

FB CV Threshold vs. V_{CC} Voltage

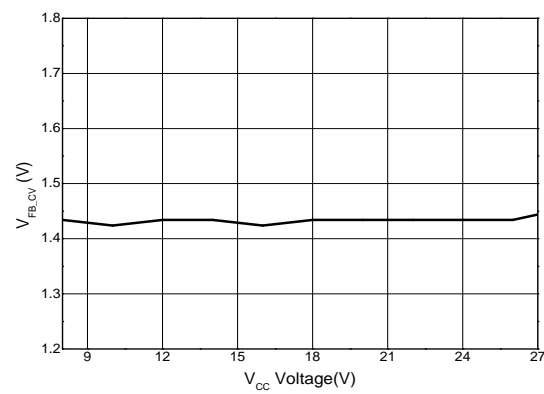

Performance Characteristics (Cont.)

Internal Reference Voltage vs. V_{CC} Voltage

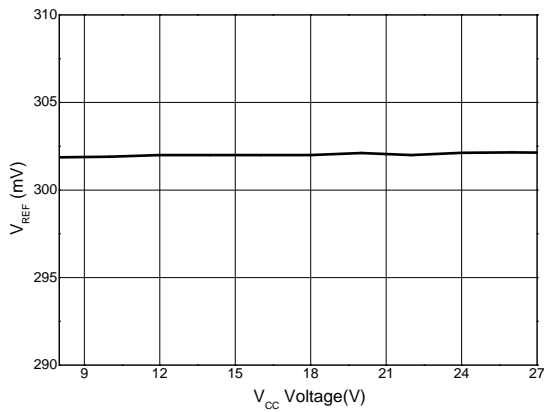

Note: 8. These electrical characteristics are tested under DC condition. The ambient temperature is equal to the junction temperature of the device.

Application Information

The AL1663/AL1663R is a constant current high PF Flyback and Buck-boost controller with primary side regulation (PSR), targeting LED lighting applications. The device eliminates the opto-couplers or the secondary feedback circuits, which will help to cost down the whole system. High power factor is achieved by constant on time operation. In order to reduce the switching losses and improve EMI performance, quasi-resonant switching mode is applied. The AL1663/AL1663R integrates multiple protections including UVLO protection, V_{CC} over voltage protection, output open voltage protection, over current protection, thermal fold-back protection and over temperature protection. The AL1663/AL1663R can support multiple dimming modes including analog dimming mode, PWM-to-DC dimming mode and PWM dimming.

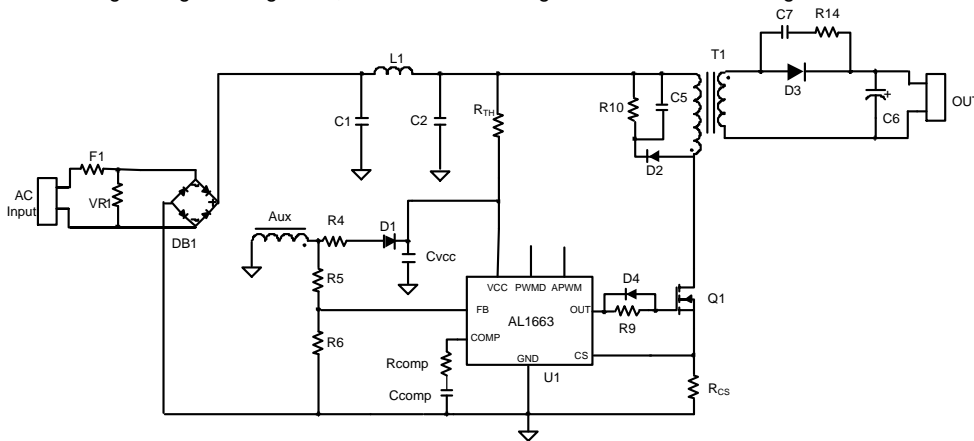

Figure 1. AL1663 Typical Flyback Application Schematic

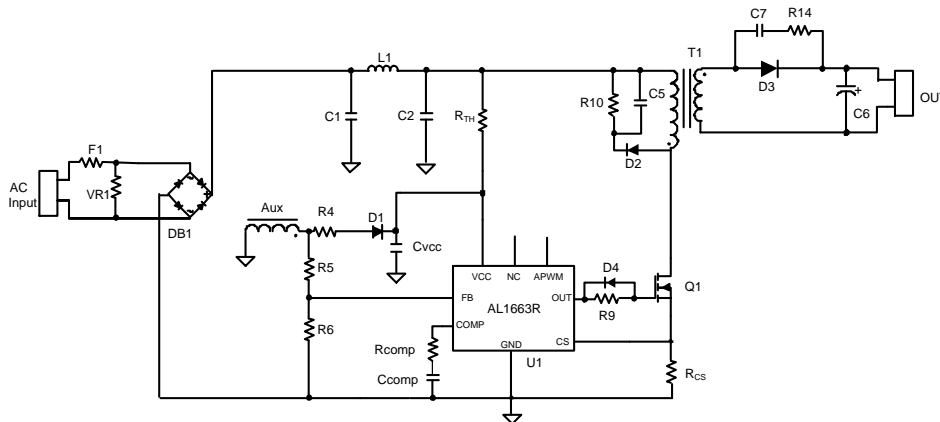

Figure 2. AL1663R Flyback Application Circuit

Application Information (Cont.)

Start-up

After AC supply is powered on, the capacitor C_{VCC} across VCC and GND pin will be charged up by BUS voltage through a start-up resistor R_{TH} . Once V_{CC} reaches V_{CC_TH} , the internal blocks start to work. V_{CC} will be supplied by V_{BUS} until the auxiliary winding of Flyback transformer could supply enough energy to maintain V_{CC} above V_{OPR_MIN} . If V_{CC} voltage is lower than V_{OPR_MIN} switch will be turned off.

After V_{CC} exceeds V_{CC_TH} , the drive block won't start to switch on/off signals until V_{COMP} is over the initial voltage V_{COMP_ST} which can be programmed by R_{COMP} . The formula is shown as below. Such design can program startup on time to reduce the startup time or reduce the output overshoot current.

$$V_{COMP_ST} = 1.4V - 700 \mu A \cdot R_{COMP}$$

Where V_{COMP_ST} is the pre-charged voltage of COMP pin. R_{COMP} is shown as Figures 1 and 2.

Generally, a big capacitance of C_{COMP} is necessary to achieve high power factor and stabilize the system loop (1 μ F to 2 μ F is recommended). The pre-charged voltage in start-up procedure can be programmed by R_{COMP} .

Protections

1. Output Open Protection (OVP)

The output voltage is reflected by the voltage on transformer's auxiliary winding. Both FB pin and VCC pin of IC integrate over voltage protection function. When there is a rapid line and load transient, the output voltage may exceed the regulated value. If V_{CC} exceeds V_{CC_OVP} or V_{FB} exceeds V_{FB_CV} , the over voltage protection will be triggered, switch will be turned off and V_{CC} will be discharged. Once V_{CC} is below V_{OPR_MIN} , the IC will shut down and be powered on again by BUS voltage through start up resistor.

Thus, output over voltage depends on the minimum voltage between both OVP protections' limitation. It can be gotten by below formula.

$$V_{OVP} = \text{Min} \left(\frac{N_s}{N_{AUX}} \cdot V_{CC_OVP}, \frac{N_s}{N_{AUX}} \cdot \frac{R5 + R6}{R6} \cdot V_{FB_CV} \right)$$

Where V_{OVP} is the output over voltage setting; R5 and R6 that is shown as Figure 1 divide reflected voltage.

N_{AUX} is the turns of auxiliary wind; N_s is turns of the secondary wind. V_{CC_OVP} is OVP Voltage of V_{CC} .

2. Output short protection (OSP)

When the output is shorted, the output voltage is clamped to zero. The output voltage of the auxiliary winding, which is proportional to the output winding, will drop down too. Once V_{CC} is below V_{OPR_MIN} , the IC will shut down and power on again by the BUS voltage through the start up resistor.

3. Over Current Protection (OCP)

The AL1663/AL1663R has a build-in cycle by cycle over current protection of primary inductor current. When CS pin voltage reaches the voltage V_{CS_OCP} , switch will be turned off until next switch period. The maximum peak current ($I_{PEAK(MAX)}$) of the inductor can be calculated as below:

$$I_{PEAK(MAX)} = \frac{V_{CS_OCP}}{R_{CS}}$$

Where V_{CS_OCP} means primary current clamp voltage that is 1.2V.

R_{CS} is current sense resistor which is shown as Figures 1 and 2.

4. Thermal Fold-back Protection (TFP)

The AL1663/AL1663R has thermal fold-back function: it adopts self-adaptive control method which can prevent the system from breaking down caused by over temperature. The overheating temperature is set at +145°C. When the temperature of the IC is higher than this point; the device will decrease the voltage reference of the CS linearly till OTP happens. By this way, the device can limit system's input power at high ambient temperature, preventing system's temperature increases further.

Application Information (Cont.)

5. Over Temperature Protection (OTP)

The AL1663/AL1663R has build-in over temperature protection (OTP) function. When the temperature goes up to +165°C, the over temperature protection will be triggered, which leads to a latch mode protection. When OTP happens, the system need to be powered off and on again to restart.

Output Constant-current Control

According to the definition of mean output current, the mean output current can be obtained as below.

$$I_{O_MEAN} = \frac{1}{\pi} \cdot \int_0^{\pi} \frac{1}{2} \cdot I_{SP} \cdot \frac{t_{ONS}}{t_{SW}} dt$$

Where I_{O_MEAN} is the mean output current; I_{SP} is secondary peak current of transformer; t_{ONS} is discharge time of secondary side of transformer; t_{SW} is the switch period.

According to the principle of AL1663/AL1663R close loop control, the voltage of R_{CS} will be sampled when switch is turned off and the value will be held until discharge time t_{ONS} is over. It can be described by following formula:

$$V_{REF} = \frac{1}{\pi} \cdot \int_0^{\pi} I_P \cdot R_{CS} \cdot \frac{t_{ONS}}{t_{SW}} dt$$

Where I_P is primary peak current of transformer; R_{CS} is current sense resistor which is shown as Figures 1 and 2.

t_{ONS} is discharge time of secondary side of transformer; t_{SW} is the switch period. V_{REF} is internal reference voltage that is equal to 0.3V.

The peak current at secondary side has following relationship with primary side peak current, if the effect of the leakage inductor is neglected.

$$I_{SP} = N_{PS} \cdot I_P$$

Where N_{PS} is the turns ratio of Flyback transformer ($N_{PS}=1$ for Buck-boost); I_P is the primary peak current of the transformer.

According to these above formulas, the mean output current can be induced finally by below expressions.

$$I_{O_MEAN} = \frac{N_{PS} \cdot V_{REF}}{2 \cdot R_{CS}}$$

Where I_{O_MEAN} is the mean output current; R_{CS} is current sense resistor which is shown as Figures 1 and 2;

V_{REF} is internal reference voltage that is equal to 0.3V; N_{PS} is the turns ratio of Flyback transformer ($N_{PS}=1$ for Buck-boost);

Therefore, the constant output current control can be realized with appropriate parameter design.

PF and THD compensation circuit

For normal application, AL1663/AL1663R can provide high PF and low THD. But there is a phase difference between input current and input voltage especially at high input voltage, thus PF and THD may not be the best situation. The below circuit can optimize this situation by reducing the phase difference. V_{BUS} is connected to the voltage point after rectifier. In normal application resistor R_{N1} is usually a several hundred kΩ resistor, R_{N2} is a hundred Ω resistor, C_{N1} is a several μF capacitor. PF and THD can be improved by debugging these components.

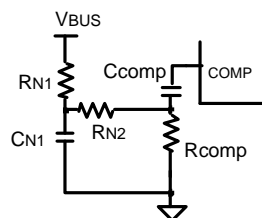

Figure 3. PF and THD Optimization Circuit

Application Information (Cont.)

Dimming Mode

The AL1663 can support three dimming modes: analog dimming, PWM-to-DC dimming and PWM dimming. The AL1663R can support two dimming modes: analog dimming and PWM dimming.

1. Analog Dimming Mode

In analog dimming mode, the dimming signal is added to APWM pin directly to realize dimming function. The setting circuit is shown as Figure 4. A capacitance of hundreds nF is recommended for C_{APWM} . When V_{APWM} is higher than 2.4V, the driver will output 100% of rated current; when the voltage V_{APWM} is in the range from 0.3 to 2.4V, the output current will change linearly with the voltage V_{APWM} . When V_{APWM} is lower than 0.3V, switch will be turned off and the output current drops to zero. The dimming curve is shown as Figure 5 and the dimming range is from 12% to 100%.

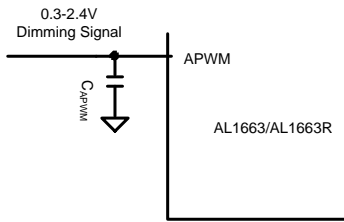

Figure 4. Analog Dimming Setting Circuit

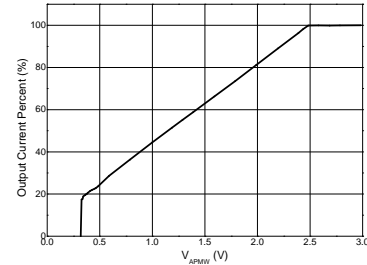

Figure 5. Analog Dimming Curve

2. PWM-to-DC Dimming Mode

In PWM-to-DC dimming mode, PWM dimming signal is added to PWMD pin. The setting circuit is shown as below Figure 6. A capacitance of hundreds nF is recommended for C_{APWM} . The duty cycle of the dimming signal D_{DIM} is reflected by the voltage on APWM pin V_{APWM} .

$$V_{APWM} = D_{DIM} \times 2.4V$$

Where D_{DIM} is duty of PWM signal; V_{APWM} is the voltage of APWM pin.

Thus the output current will change with the duty cycle of dimming signal D_{DIM} . For example, the dimming curve is shown as Figure 7. The dimming range is 12% to 100%.

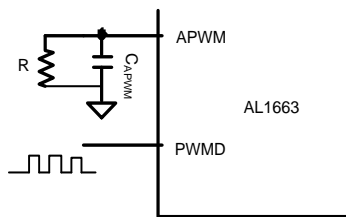

Figure 6. PWM to DC Dimming Setting Circuit

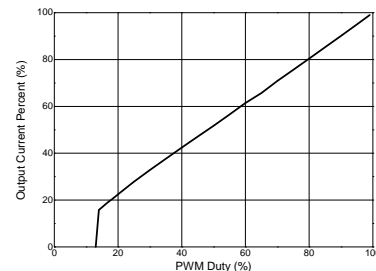

Figure 7. PWM to DC Dimming Curve (PWM Frequency is 500Hz)

3. PWM Dimming Mode

In PWM dimming mode, dimming signal will be added to APWM pin. The setting circuit is shown as Figure 8. The output current is chopped by the dimming signal directly. The logic high level of the dimming signal need to be higher 2.4V while the logic low level is lower than 0.3V. Switch is turned off at logic low level. The dimming curve is shown as Figure 9. The dimming range can be 100 to 1% with 1KHz frequency of PWM signal.

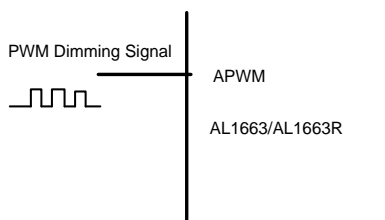

Figure 8. PWM Dimming Setting Circuit

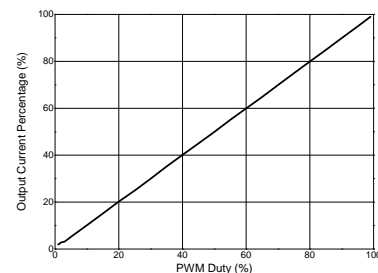

Figure 9. PWM Dimming Curve (PWM Frequency is 1 KHz)

Application Information (Cont.)

Operation Parameters Design

Setting the Current Sense Resistor R_{CS}

The current sense resistance can be calculated as following:

$$R_{CS} = \frac{N_{PS} \cdot V_{REF}}{2 \cdot I_{O_MEAN}}$$

Where I_{O_MEAN} is the mean output current; R_{CS} is current sense resistor which is shown as Figures 1 and 2;

V_{REF} is internal reference voltage that is equal to 0.3V; N_{PS} is the turns ratio of Flyback transformer ($N_{PS}=1$ for Buck-boost).

Setting Transformer Selection (T1)

N_{PS} is limited by the electrical stress of the switch MOSFET, can be calculated by below formula.

$$N_{PS} \leq \frac{V_{MOS_ (BR)DS} \cdot 90\% - \sqrt{2} \cdot V_{IN_MAX} - \Delta V_S}{V_O + V_{D_F}}$$

Where $V_{MOS_ (BR)DS}$ is the breakdown voltage of the switch MOSFET. V_{IN_MAX} is the max rated input voltage. ΔV_S is the overshoot voltage clamped by RCD snobbier during OFF time. V_O is the output voltage. V_{D_F} is the forward voltage of secondary diode. N_{PS} is the turns ratio of Flyback transformer ($N_{PS}=1$ for Buck-boost);

For boundary conduction mode and constant on time method, the peak current of primary inductance can be calculated as below.

$$I_P = \frac{2 \cdot \pi \cdot I_{O_MEAN}}{N_{PS} \cdot \int_0^\pi \sin(\theta) \cdot \frac{\sqrt{2} \cdot V_{IN_RMS} \cdot \sin(\theta)}{\sqrt{2} \cdot V_{IN_RMS} \cdot \sin(\theta) + N_{PS} \cdot V_O} d\theta}$$

Where V_{IN_RMS} is the rate input voltage; I_P is the primary inductance current. N_{PS} is the turns ratio of Flyback transformer ($N_{PS}=1$ for Buck-boost); I_{O_MEAN} is the mean output current; V_O is the output voltage.

The switching frequency is not constant for AL1663/AL1663R due to boundary conduction mode. To set the minimum switching frequency f_{MIN} at the crest of the minimum AC input, primary inductance can be obtained by below formula.

$$L_P = \frac{\sqrt{2} \cdot V_{IN_RMS} \cdot N_{PS} \cdot V_O}{I_P \cdot (\sqrt{2} V_{IN_RMS} + N_{PS} V_O) \cdot f_{MIN}}$$

Where V_{IN_RMS} is the rate input voltage; I_P is the primary inductance current. N_{PS} is the turns ratio of Flyback transformer ($N_{PS}=1$ for Buck-boost);

I_{O_MEAN} is the mean output current; V_O is the output voltage; f_{MIN} is the minimum switching frequency at the crest of the minimum AC input.

According to the Faraday's Law, the winding number of the inductance can be calculated by:

$$N_P = \frac{L_P \cdot I_P}{A_e \cdot B_m}$$

$$N_S = \frac{N_P}{N_{PS}}$$

Where,

A_e is the core effective area.

B_m is the maximum magnetic flux density.

Ordering Information

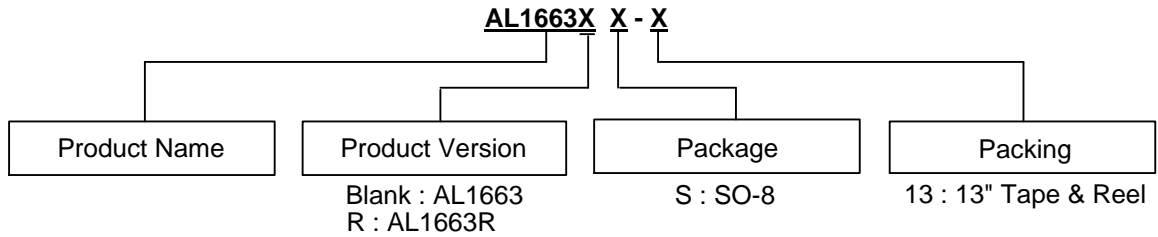

Part Number	Package Code	Package	13" Tape and Reel	
			Quantity	Part Number Suffix
AL1663S-13	S	SO-8	4000/Tape & Reel	-13
AL1663RS-13	S	SO-8	4000/Tape & Reel	-13

Marking Information

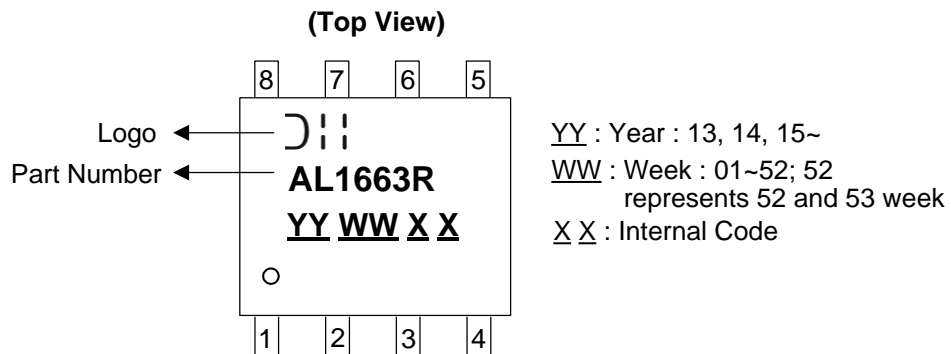
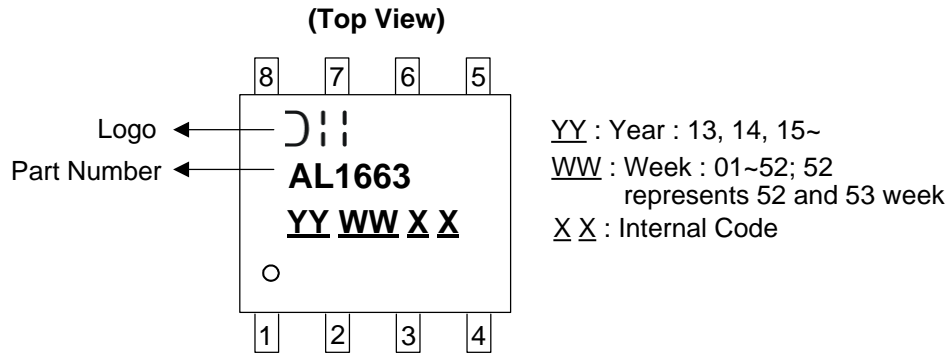

Package Outline Dimensions (All dimensions in mm.)

(1) Package Type: SO-8

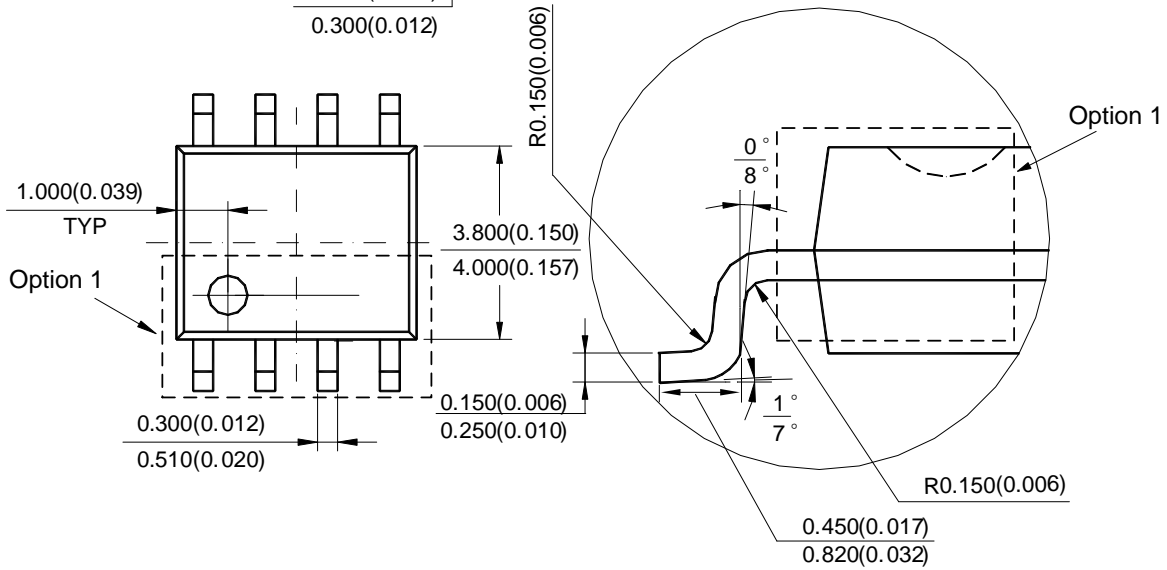
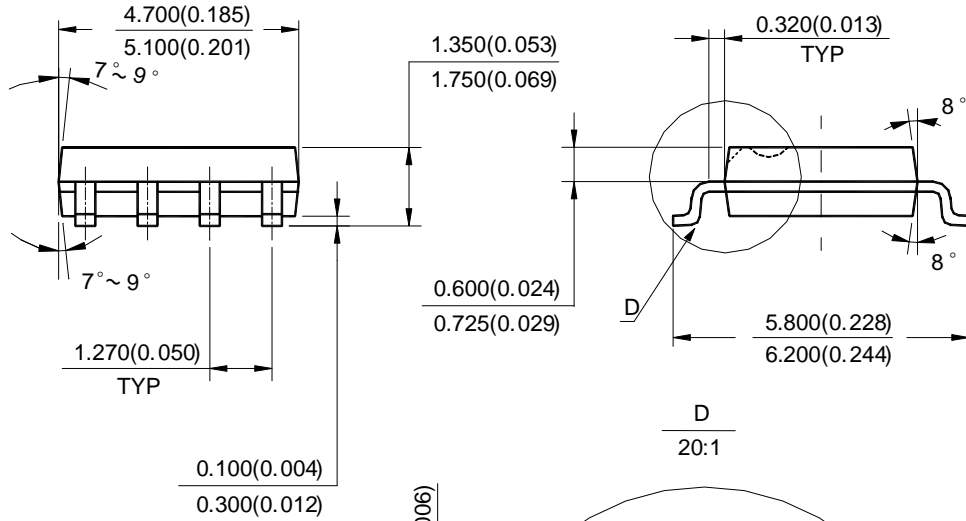

Option 2

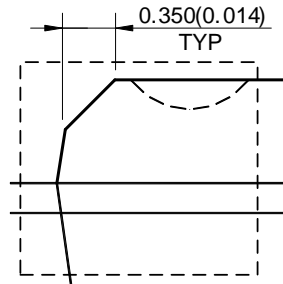
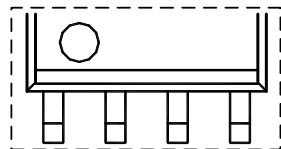

Note: Eject hole, oriented hole and mold mark is optional.

NEW PRODUCT

Suggested Pad Layout

(1) Package Type: SO-8

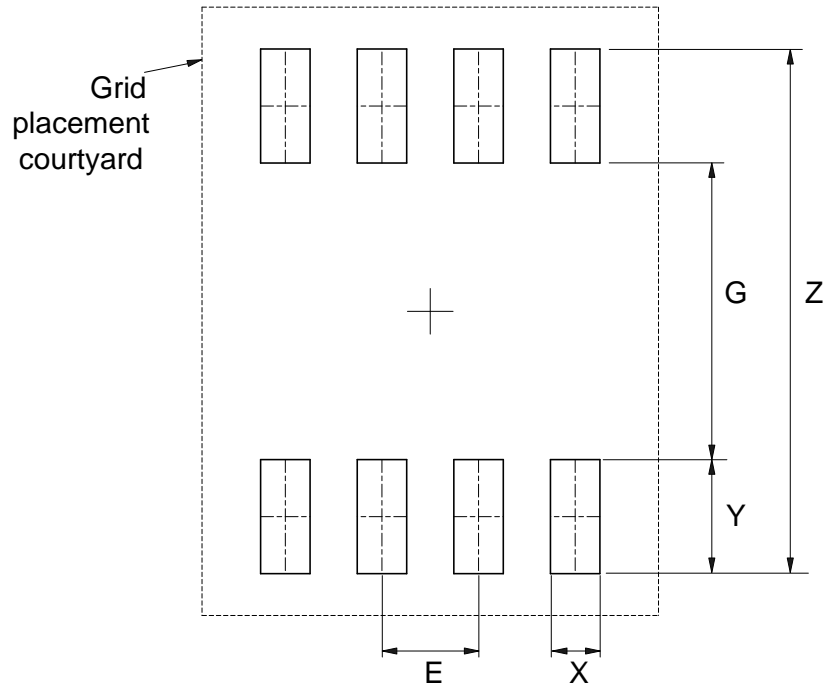

Dimensions	Z (mm)/(inch)	G (mm)/(inch)	X (mm)/(inch)	Y (mm)/(inch)	E (mm)/(inch)
Value	6.900/0.272	3.900/0.154	0.650/0.026	1.500/0.059	1.270/0.050

NEW PRODUCT

IMPORTANT NOTICE

DIODES INCORPORATED MAKES NO WARRANTY OF ANY KIND, EXPRESS OR IMPLIED, WITH REGARDS TO THIS DOCUMENT, INCLUDING, BUT NOT LIMITED TO, THE IMPLIED WARRANTIES OF MERCHANTABILITY AND FITNESS FOR A PARTICULAR PURPOSE (AND THEIR EQUIVALENTS UNDER THE LAWS OF ANY JURISDICTION).

Diodes Incorporated and its subsidiaries reserve the right to make modifications, enhancements, improvements, corrections or other changes without further notice to this document and any product described herein. Diodes Incorporated does not assume any liability arising out of the application or use of this document or any product described herein; neither does Diodes Incorporated convey any license under its patent or trademark rights, nor the rights of others. Any Customer or user of this document or products described herein in such applications shall assume all risks of such use and will agree to hold Diodes Incorporated and all the companies whose products are represented on Diodes Incorporated website, harmless against all damages.

Diodes Incorporated does not warrant or accept any liability whatsoever in respect of any products purchased through unauthorized sales channel. Should Customers purchase or use Diodes Incorporated products for any unintended or unauthorized application, Customers shall indemnify and hold Diodes Incorporated and its representatives harmless against all claims, damages, expenses, and attorney fees arising out of, directly or indirectly, any claim of personal injury or death associated with such unintended or unauthorized application.

Products described herein may be covered by one or more United States, international or foreign patents pending. Product names and markings noted herein may also be covered by one or more United States, international or foreign trademarks.

This document is written in English but may be translated into multiple languages for reference. Only the English version of this document is the final and determinative format released by Diodes Incorporated.

LIFE SUPPORT

Diodes Incorporated products are specifically not authorized for use as critical components in life support devices or systems without the express written approval of the Chief Executive Officer of Diodes Incorporated. As used herein:

A. Life support devices or systems are devices or systems which:

1. are intended to implant into the body, or
2. support or sustain life and whose failure to perform when properly used in accordance with instructions for use provided in the labeling can be reasonably expected to result in significant injury to the user.

B. A critical component is any component in a life support device or system whose failure to perform can be reasonably expected to cause the failure of the life support device or to affect its safety or effectiveness.

Customers represent that they have all necessary expertise in the safety and regulatory ramifications of their life support devices or systems, and acknowledge and agree that they are solely responsible for all legal, regulatory and safety-related requirements concerning their products and any use of Diodes Incorporated products in such safety-critical, life support devices or systems, notwithstanding any devices- or systems-related information or support that may be provided by Diodes Incorporated. Further, Customers must fully indemnify Diodes Incorporated and its representatives against any damages arising out of the use of Diodes Incorporated products in such safety-critical, life support devices or systems.

Copyright © 2016, Diodes Incorporated

www.diodes.com