

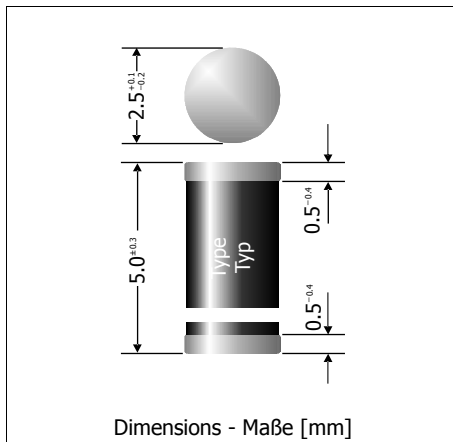

SMZ10B ... SMZ200B (2 W, 2%)

Surface Mount Silicon-Zener Diodes (non-planar technology) Flächendiffundierte Si-Zener-Dioden für die Oberflächenmontage

Version 2015-05-13



Maximum power dissipation Maximale Verlustleistung	2 W
Nominal Z-voltage Nominale Z-Spannung	10...200 V
Plastic case MELF Kunststoffgehäuse MELF	DO-213AB
Weight approx. – Gewicht ca.	0.12 g
Plastic material has UL classification 94V-0 Gehäusematerial UL94V-0 klassifiziert	
Standard packaging taped and reeled Standard Lieferform gegurtet auf Rolle	

Zener voltage is selected to a tolerance of $\sim \pm 2\%$.

Die Zener-Spannung ist selektiert auf $\sim \pm 2\%$ Toleranz.

Maximum ratings and Characteristics

Grenz- und Kennwerte

		SMZ-series	
Power dissipation Verlustleistung	$T_A = 50^\circ\text{C}$	P_{tot}	2 W ¹⁾
Non repetitive peak power dissipation, $t < 1$ ms Einmalige Impuls-Verlustleistung, $t < 1$ ms	$T_A = 25^\circ\text{C}$	P_{ZSM}	60 W
Max. operating junction temperature – Max. Sperrschichttemperatur Storage temperature – Lagerungstemperatur		T_j T_s	+150°C -50...+175°C
Thermal resistance junction to ambient air Wärmewiderstand Sperrschicht – umgebende Luft		R_{thA}	<45 K/W ¹⁾
Thermal resistance junction to terminal Wärmewiderstand Sperrschicht – Anschluss		R_{thT}	<15 K/W
Zener voltages see table on next page – Zener-Spannungen siehe Tabelle auf der nächsten Seite			

- 1 Mounted on P.C. board with 50 mm² copper pads at each terminal
Montage auf Leiterplatte mit 50 mm² Kupferbelag (Löt-pad) an jedem Anschluss
- 2 Tested with pulses – Gemessen mit Impulsen

Maximum ratings and Characteristics

 (T_j = 25°C unless otherwise specified)

Grenz- und Kennwerte

 (T_j = 25°C wenn nicht anders spezifiziert)

Type Typ	Zener voltage ²⁾ Zener-Spannung ²⁾ I _Z = I _{Ztest}		Test current Meßstrom I _{Ztest} [mA]	Dynamic resistance Diff. Widerstand I _{Ztest} / f = 1 kHz r _{zi} [Ω]	Temp. Coeffiz. of Z-voltage ...der Z-Spannung α _{VZ} [10 ⁻⁴ /°C]	Reverse volt. Sperrspanng. I _R = 1 μA V _R [V]	Z-current ¹⁾ Z-Strom ¹⁾ T _A = 50°C I _{Zmax} [mA]
	V _{Zmin} [V]	V _{Zmax} [V]					
SMZ10B	9.79	10.21	50	2 (<4)	+5...+9	> 5	189
SMZ11B	10.79	11.21	50	4 (<7)	+5...+10	> 5	172
SMZ12B	11.79	12.21	50	4 (<7)	+5...+10	> 7	157
SMZ13B	12.68	13.32	50	5 (<10)	+5...+10	> 7	142
SMZ15B	14.68	15.32	50	5 (<10)	+5...+10	> 10	128
SMZ16B	15.68	16.32	25	6 (<15)	+6...+11	> 10	117
SMZ18B	17.58	18.42	25	6 (<15)	+6...+11	> 10	105
SMZ20B	19.58	20.42	25	6 (<15)	+6...+11	> 10	94
SMZ22B	21.58	22.42	25	6 (<15)	+6...+11	> 12	86
SMZ24B	23.48	24.52	25	7 (<15)	+6...+11	> 12	78
SMZ27B	26.48	27.52	25	7 (<15)	+6...+11	> 14	69
SMZ30B	29.38	30.62	25	8 (<15)	+6...+11	> 14	63
SMZ33B	32.3	33.8	25	8 (<15)	+6...+11	> 17	57
SMZ36B	35.2	36.8	10	16 (<40)	+6...+11	> 17	53
SMZ39B	38.1	39.9	10	20 (<40)	+6...+11	> 20	49
SMZ43B	42.0	44.0	10	24 (<45)	+7...+12	> 20	43
SMZ47B	46.0	48.0	10	24 (<45)	+7...+12	> 24	40
SMZ51B	49.9	52.1	10	25 (<60)	+7...+12	> 24	37
SMZ56B	54.8	57.2	10	25 (<60)	+7...+12	> 28	33
SMZ62B	60.7	63.3	10	25 (<80)	+8...+13	> 28	30
SMZ68B	66.5	69.5	10	25 (<80)	+8...+13	> 34	28
SMZ75B	73.4	76.6	10	30 (<100)	+8...+13	> 34	25
SMZ82B	80.3	83.7	10	30 (<100)	+8...+13	> 41	23
SMZ91B	89.1	92.9	5	40 (<200)	+9...+13	> 41	21
SMZ100B	97.9	102.1	5	60 (<200)	+9...+13	> 50	19
SMZ110B	108	112	5	80 (<250)	+9...+13	> 50	18
SMZ120B	118	122	5	80 (<250)	+9...+13	> 60	16
SMZ130B	127	133	5	90 (<300)	+9...+13	> 60	15
SMZ150B	147	153	5	100 (<300)	+9...+13	> 75	13
SMZ160B	157	163	5	110 (<350)	+9...+13	> 75	12
SMZ180B	176	184	5	120 (<350)	+9...+13	> 90	11
SMZ200B	196	204	5	150 (<350)	+9...+13	> 90	10

1 Notes see previous page – Fußnoten siehe vorhergehende Seite

