



M.S.KENNEDY CORP.

THREE PHASE BRIDGE MOSFET POWER MODULE

3017

4707 Dey Road Liverpool, N.Y. 13088

(315) 701-6751

FEATURES:

- All N-Channel Mosfets
- Isolated Package for Direct Heat Sinking, Excellent Thermal Conductivity
- Avalanche Rated Devices
- Interfaces with Most Brushless Motor Drive IC's
- 200 Volt, 30 Amp Full Three Phase Bridge at 25°C

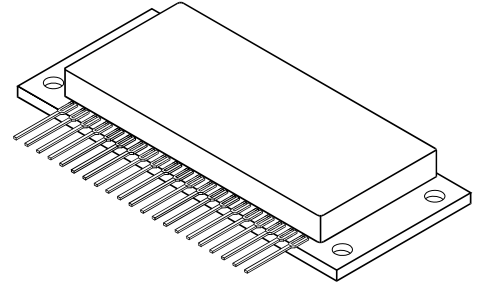

DESCRIPTION:

The MSK 3017 is an all N-Channel three phase power MOSFET Bridge Circuit. Packaged in a space efficient isolated ceramic tab power SIP that allows for direct heat sinking, the MSK 3017 can be interfaced with a wide array of brushless motor drive IC's. The MSK 3017 uses M.S Kennedy's proven power hybrid technology to produce a cost effective high performance circuit for use in today's sophisticated servo motor and disk drive systems.

EQUIVALENT SCHEMATIC

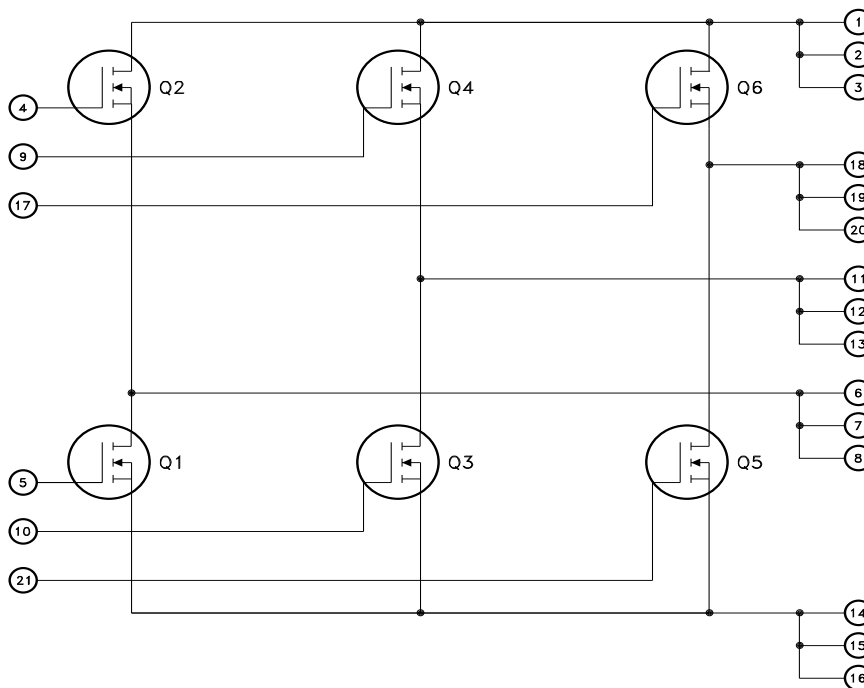

TYPICAL APPLICATIONS

- Three Phase Brushless DC Motor Servo Control
- Disk Drive Spindle Control
- Fin Actuator Control
- Az-El Antenna Control

PIN-OUT INFORMATION

1 Drain Q2, Q4, Q6	12 Drain Q3, Source Q4
2 Drain Q2, Q4, Q6	13 Drain Q3, Source Q4
3 Drain Q2, Q4, Q6	14 Source Q1, Q3, Q5
4 Gate Q2	15 Source Q1, Q3, Q5
5 Gate Q1	16 Source Q1, Q3, Q5
6 Drain Q1, Source Q2	17 Gate Q6
7 Drain Q1, Source Q2	18 Drain Q5, Source Q6
8 Drain Q1, Source Q2	19 Drain Q5, Source Q6
9 Gate Q4	20 Drain Q5, Source Q6
10 Gate Q3	21 Gate Q5
11 Drain Q3, Source Q4	

ABSOLUTE MAXIMUM RATINGS

VDSS	Drain to Source Voltage	200V MAX
VDGDR	Drain to Gate Voltage (R _{GS} = 1MΩ)	200V MAX
VGS	Gate to Source Voltage (Continuous)	± 20V MAX
ID	Continuous Current	30A MAX
IDM	Pulsed Current	46A MAX
RTH-JC	Thermal Resistance (Junction to Case)@25°C	1.0°C/W
RTH-JC	Thermal Resistance (Junction to Case)@125°C	1.6°C/W

	Single Pulse Avalanche Energy	1000 mJ
T _J	Junction Temperature	+ 150°C MAX
T _{ST}	Storage Temperature	-55°C to + 150°C
T _C	Case Operating Temperature Range	-55°C to + 125°C
T _{LD}	Lead Temperature Range (10 Seconds Lead Only)	200°C MAX

ELECTRICAL SPECIFICATIONS

Parameter	Test Conditions ④	MSK3017			Units
		Min.	Typ.	Max.	
Drain-Source Breakdown Voltage	V _{GS} = 0 I _D = 0.25mA	200	-	-	V
Drain-Source Leakage Current	V _{DS} = 200V V _{GS} = 0V	-	-	250	μA
Gate-Source Leakage Current	V _{GS} = ± 20V V _{DS} = 0	-	-	± 100	nA
Gate-Source Threshold Voltage	V _{DS} = V _{GS} I _D = 250μA	2.0	-	4.0	V
Drain-Source On Resistance ②	V _{GS} = 10V I _D = 30A	-	-	0.09	Ω
Drain-Source On Resistance ③	V _{GS} = 10V I _D = 30A	-	-	0.06	Ω
Forward Transconductance ①	V _{DS} = 50V I _D = 30A	24	-	-	S
Total Gate Charge ①	I _D = 30A	-	-	230	nC
Gate-Source Charge ①	V _{DS} = 160V	-	-	42	nC
Gate-Drain Charge ①	V _{GS} = 10V	-	-	110	nC
Turn-On Delay Time ①	V _{DD} = 100V	-	23	-	nS
Rise Time ①	I _D = 30A	-	120	-	nS
Turn-Off Delay Time ①	R _G = 4.3Ω	-	100	-	nS
Fall Time ①	R _D = 2.1Ω	-	94	-	nS
Input Capacitance ①	V _{GS} = 0V	-	5200	-	pF
Output Capacitance ①	V _{DS} = 25V	-	1200	-	pF
Reverse Transfer Capacitance ①	f = 1MHz	-	310	-	pF
Body Diode					
Forward On Voltage ①	I _S = 30 A V _{GS} = 0V	-	1.8	-	V
Reverse Recovery Time ①	I _S = 30 A di/dt = 100A/μS	-	390	590	nS
Reverse Recovery Charge ①		-	4.8	7.2	μC

NOTES:

- ① This parameter is guaranteed by design but need not be tested. Typical parameters are representative of actual device performance but are for reference only.
- ② Resistance as seen at package pins.
- ③ Resistance for die only; use for thermal calculations.
- ④ T_A = 25°C unless otherwise specified.

APPLICATION NOTES

BRIDGE DRIVE CONSIDERATIONS

It is important that the logic used to turn ON and OFF the various transistors allow sufficient "dead time" between a high side transistor and its low side transistor to make sure that at no time are they both ON. When they are, this is called "shoot-through", and it places a momentary short across the power supply. This overly stresses the transistors and causes excessive noise as well. See Figure 1.

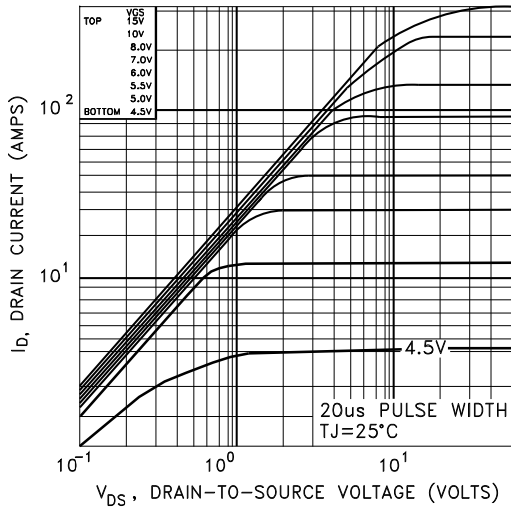

Figure 1

This deadtime should allow for the turn on and turn off time of the transistors, especially when slowing them down with gate resistors. This situation will be present when switching motor direction, or when sophisticated timing schemes are used for servo systems such as locked antiphase PWM'ing for high bandwidth operation.

TYPICAL PERFORMANCE CURVES

TYPICAL OUTPUT CHARACTERISTICS $T_c = 25^\circ\text{C}$



TYPICAL CAPACITANCE vs DRAIN TO SOURCE VOLTAGE

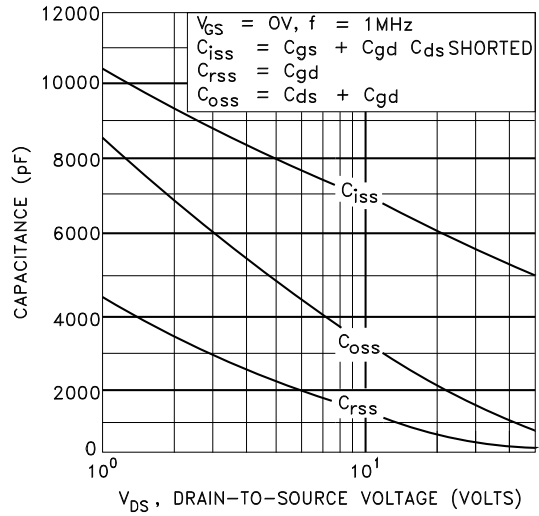

TYPICAL TRANSFER CHARACTERISTICS

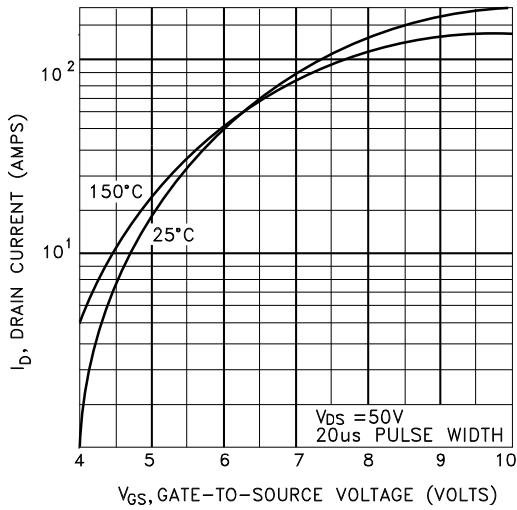

TYPICAL GATE CHARGE vs GATE TO SOURCE VOLTAGE (VOLTS)

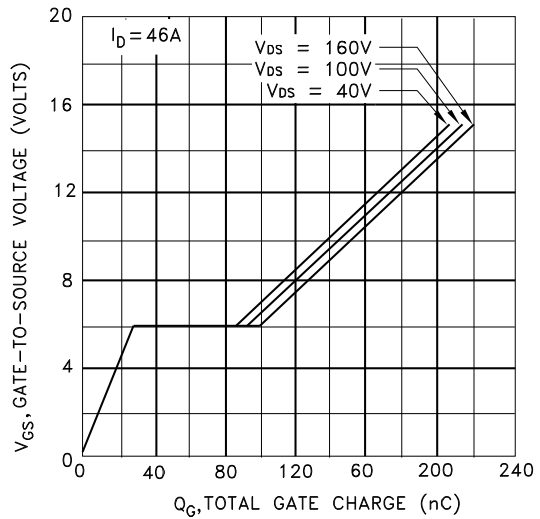

TYPICAL SOURCE-DRAIN DIODE FORWARD VOLTAGE

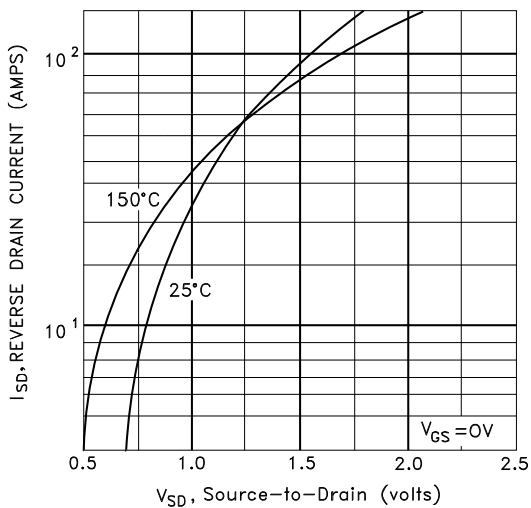

NORMALIZED ON-RESISTANCE vs TEMPERATURE

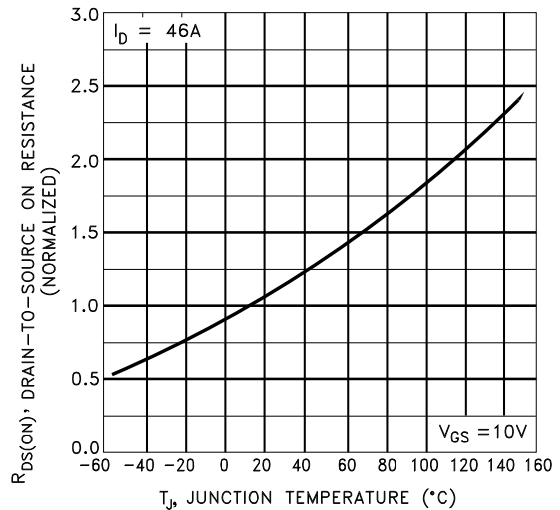

MECHANICAL SPECIFICATIONS

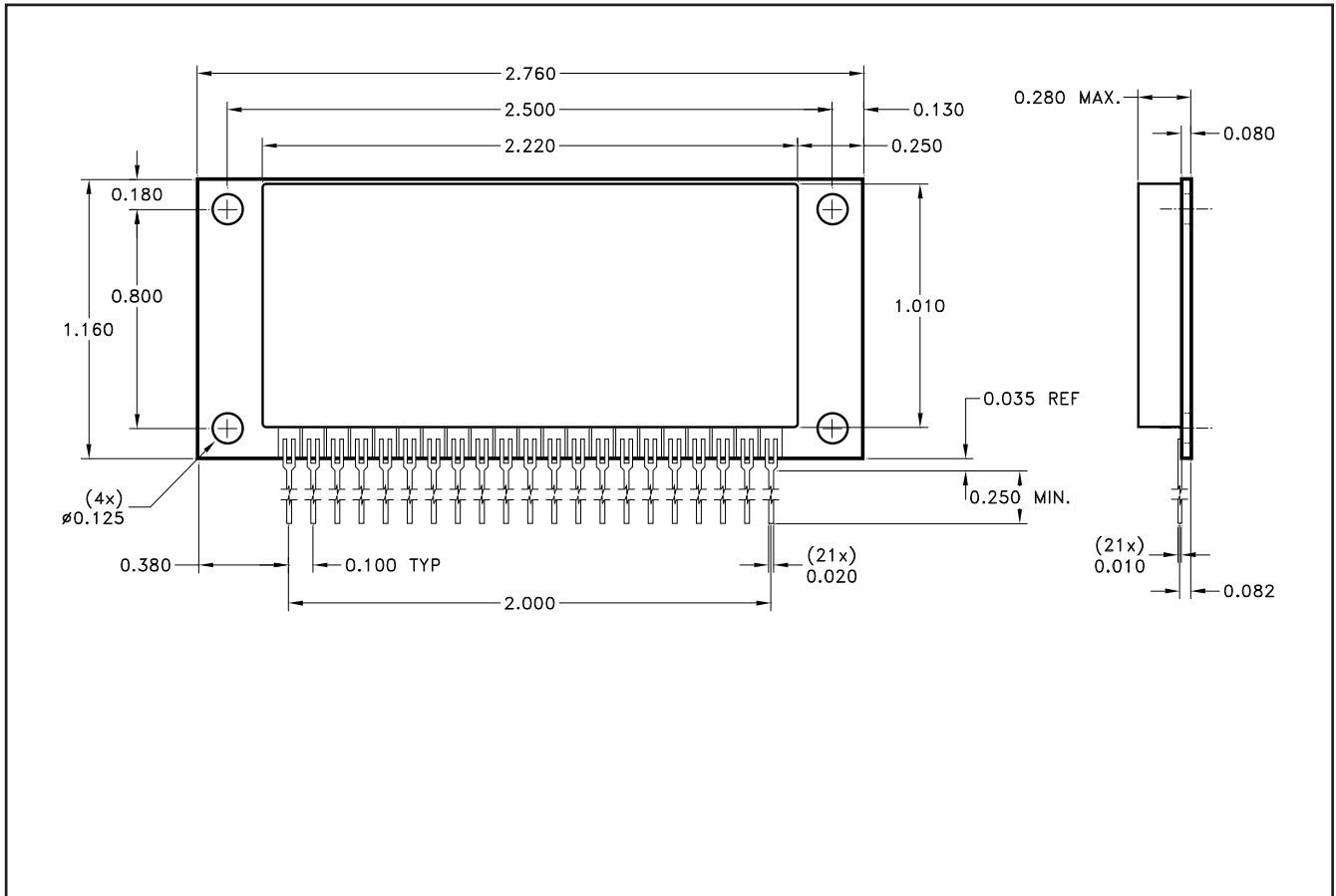

ALL DIMENSIONS ARE ± 0.010 INCHES UNLESS OTHERWISE LABELED.

ORDERING INFORMATION

Part Number	Screening Level
MSK 3017	Industrial

M.S. Kennedy Corp.
 4707 Dey Road, Liverpool, New York 13088
 Phone (315) 701-6751
 FAX (315) 701-6752
www.mskennedy.com

The information contained herein is believed to be accurate at the time of printing. MSK reserves the right to make changes to its products or specifications without notice, however, and assumes no liability for the use of its products. Please visit our website for the most recent revision of this datasheet.