



3CT2A

主要参数 MAIN CHARACTERISTICS

$I_{T(AV)}$	2.0 A
V_{DRM}/V_{RRM}	500 V
I_{GT}	10-140 μ A

用途

- 半交流开关
- 相位控制

APPLICATIONS

- Half AC switching
- Phase control

产品特性

- 玻璃钝化芯片，高可靠性和一致性
- 低通态电流和高浪涌电流能力
- 环保 RoHS 产品

FEATURES

- Glass-passivated mesa chip for reliability and uniform
- Low on-state voltage and High I_{TSM}
- RoHS products

封装 Package

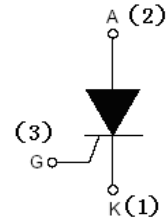

序号 Pin	引线名称 Description
1	阴极 K
2	阳极 A
3	门极 G

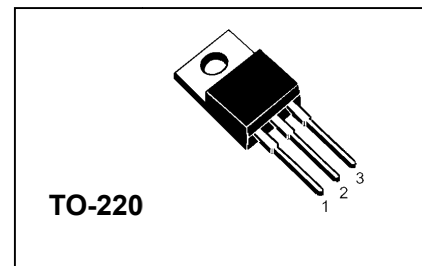
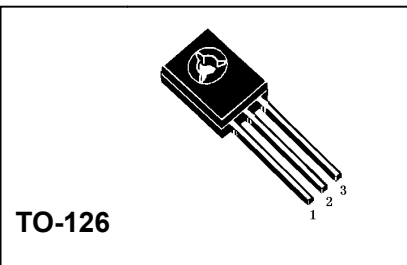

订货信息 ORDER MESSAGE

订货型号 Order codes	印记 Marking	无卤素 Halogen Free	封装 Package	包装 Packaging
3CT2A -O-Z-N-C	3CT2A	否 NO	TO-220	袋装 Bag
3CT2A-O-M-N-C	3CT2A	否 NO	TO-126	袋装 Bag



绝对最大额定值 ABSOLUTE RATINGS ($T_c=25^\circ\text{C}$)

项 目 Parameter	符 号 Symbol	数 值 Value	单 位 Unit
断态重复峰值电压 Repetitive peak off-state voltage	V_{DRM}	500	V
反向重复峰值电压 Repetitive peak reverse voltage	V_{RRM}	500	V
通态平均电流 Average on-state current	$I_{\text{T(AV)}}$	2.0	A
通态方均根电流 On-state RMS current (half sine wave)	$I_{\text{T(RMS)}}$	3.2	A
非重复浪涌峰值通态电流 Non-repetitive surge peak on-state current (half sine wave, $t=10\text{ms}$)	I_{TSM}	20	A
I^2t for fusing ($t=10\text{ms}$)	I^2t	2.0	A^2s
门极峰值电流 Peak gate current	I_{GM}	1	A
门极峰值电压 Peak gate voltage	V_{GM}	5	V
反向门极峰值电压 Peak reverses gate voltage	V_{RGM}	5	V
平均门极功率 Average gate power(over any 20ms period)	$P_{\text{G(AV)}}$	0.5	W
存储温度 Storage temperature	T_{stg}	-40~150	$^\circ\text{C}$
操作结温 Operation junction temperature	T_{J}	125	$^\circ\text{C}$

电特性 ELECTRICAL CHARACTERISTIC ($T_c=25^\circ\text{C}$ unless otherwise stated)

项 目 Parameter	符号 Symbol	测试条件 Tests conditions	最小 min	典型 typ	最大 max	单位 Unit
断态峰值重复电流 Peak Repetitive Blocking Current	I_{DRM}	$V_{\text{DM}}=V_{\text{DRM}}, T_{\text{J}}=125^\circ\text{C}, R_{\text{GK}}=1\text{K}\Omega$	-	-	0.5	mA
反向峰值重复电流 Peak Repetitive Reverse Current	I_{RRM}	$V_{\text{RM}}=V_{\text{RRM}}, T_{\text{J}}=125^\circ\text{C}, R_{\text{GK}}=1\text{K}\Omega$	-	-	0.5	mA
峰值通态电压 Peak on-state voltage	V_{TM}	$I_{\text{TM}}=4\text{A}$	-	-	1.7	V
门极触发电流 Gate trigger current	I_{GT}	$V_{\text{DM}}=12\text{V}, I_{\text{T}}=0.1\text{A}$	10	-	140	μA
门极触发电压 Gate trigger voltage	V_{GT}	$V_{\text{DM}}=12\text{V}, I_{\text{T}}=0.1\text{A}$	-	0.60	0.8	V
维持电流 Holding current	I_{H}	$V_{\text{DM}}=12\text{V}, I_{\text{GT}}=0.1\text{A}$	-	-	5	mA
擎住电流 Latching current	I_{L}	$V_{\text{DM}}=12\text{V}, I_{\text{GT}}=0.1\text{A}$	-	-	10	mA

动态特性 DYNAMIC CHARACTERISTICS ($T_c=25^\circ\text{C}$ unless otherwise stated)

项 目 Parameter	符号 Symbol	测试条件 Tests conditions	最小 min	典型 typ	最大 max	单位 Unit
断态临界电压上升率 Critical rate of rise of off-state voltage	dV/dt	$V_{\text{DM}}=67\% V_{\text{DRM(MAX)}}, T_{\text{J}}=125^\circ\text{C}, R_{\text{GK}}=1\text{K}\Omega$	10	-	-	$\text{V}/\mu\text{s}$





热特性 THERMAL CHARACTERISTIC

项 目 Parameter	符 号 Symbol	值 value	单 位 Unit
结到管壳的热阻 Thermal resistance junction to case	TO-126	$R_{th(j-c)}$	3.0 max
	TO-220	$R_{th(j-c)}$	1.3 max
结到环境的热阻 Thermal resistance junction to ambient(half cycle)	TO-126	$R_{th(j-a)}$	75 max
	TO-220	$R_{th(j-a)}$	60 typ

特征曲线 ELECTRICAL CHARACTERISTICS (curves)

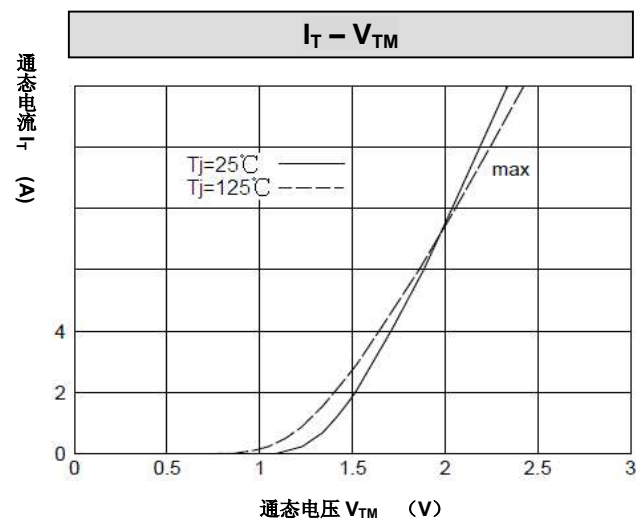
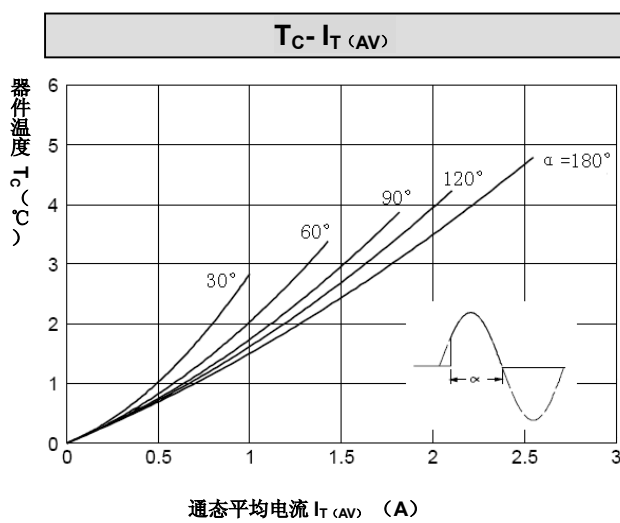



外形尺寸 PACKAGE MECHANICAL DATA
TO-126

单位 Unit : mm

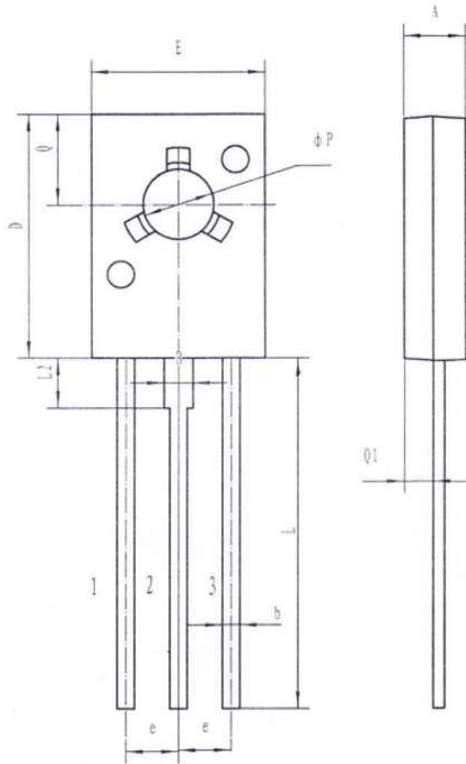

A	2.50-2.90
B	1.22-1.47
b	0.60-0.90
c	0.30-0.70
D	10.50-11.10
E	7.10-8.10
e	2.19-2.39
L	15.30-15.70
L2	2.10-2.30
Q	3.80-4.20
Q1	1.07-1.47
P	3.00-3.20

TO-220

单位 Unit : mm

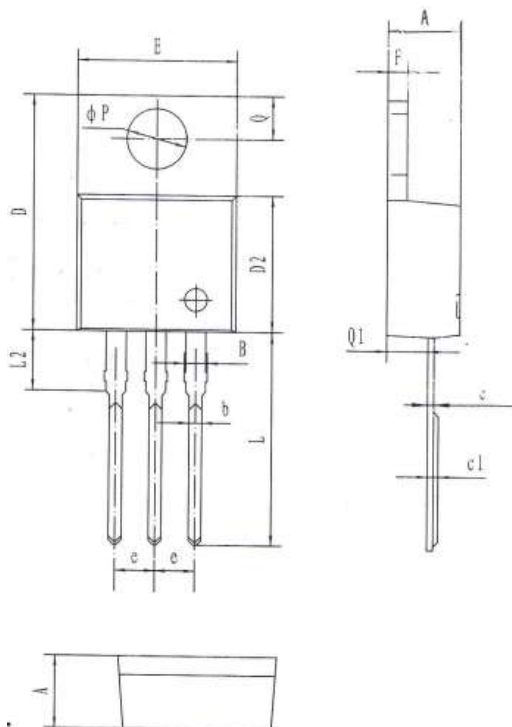

A	4.40-4.80
B	1.10-1.40
b	0.70-0.95
c	0.28-0.48
c1	0.32-0.52
D	14.45-16.00
D2	8.20-9.20
E	9.60-10.40
e	2.39-2.69
F	1.20-1.35
L	13.05-14.05
L2	3.70-3.90
Q	2.40-3.00
Q1	2.20-2.90
P	3.50-4.00



**注意事项**

- 1.吉林华微电子股份有限公司的产品销售分为直销和销售代理，无论哪种方式，订货时请与公司核实。
- 2.购买时请认清公司商标，如有疑问请与公司本部联系。
- 3.在电路设计时请不要超过器件的绝对最大额定值，否则会影响整机的可靠性。
- 4.本说明书如有版本变更不另外告知

NOTE

1. Jilin Sino-microelectronics co., Ltd sales its product either through direct sales or sales agent, thus, for customers, when ordering , please check with our company.
2. We strongly recommend customers check carefully on the trademark when buying our product, if there is any question, please don't be hesitate to contact us.
3. Please do not exceed the absolute maximum ratings of the device when circuit designing.
4. Jilin Sino-microelectronics co., Ltd reserves the right to make changes in this specification sheet and is subject to change without prior notice.

联系方式**吉林华微电子股份有限公司**

公司地址：吉林省吉林市深圳街 99 号

邮编：132013

总机：86-432-64678411

传真：86-432-64665812

网址：www.hwdz.com.cn**市场营销部**

地址：吉林省吉林市深圳街 99 号

邮编：132013

电话：86-432-64675588

64675688

64678411

传真：86-432-64671533

CONTACT**JILIN SINO-MICROELECTRONICS CO., LTD.**

ADD: No.99 Shenzhen Street, Jilin City, Jilin Province, China.

Post Code: 132013

Tel: 86-432-64678411

Fax: 86-432-64665812

Web Site: www.hwdz.com.cn**MARKET DEPARTMENT**

ADD: No.99 Shenzhen Street, Jilin City, Jilin Province, China.

Post Code: 132013

Tel: 86-432-64675588

64675688

64678411

Fax: 86-432-64671533

附录（Appendix）：修订记录（Revision History）

日期 Date	旧版本 Last Rev.	新版本 New Rev.	修订内容 Description of Changes
2015-10-22		201510B	修订外形尺寸、排版

