



ACE710C

1A Synchronous PWM Boost converter

Description

The ACE710C is a step-up converter that provides a boosted output voltage from a low voltage source. Because of its proprietary design, it starts up at a very low input voltage down to 0.9V, and only consumes 15uA at standby, making it an ideal choice for single cell alkaline/NiMH battery operations.

A switching frequency of 1MHz minimizes solution footprint by allowing the use of tiny, low profile inductors and ceramic capacitors. The current mode PWM design is internally compensated, reducing external parts count.

ACE710C is available in SOT23-5 Package.

Features

- Efficiency up to 95% @ $V_{in}=4.0V$, $V_{out}=5.0V$
- Typical 15uA standby current
- 1MHz Switching Frequency allows small inductor and output cap
- Input boost-strapping allows using small or no input cap
- Low V_{in} Start-up Voltage down to 0.9V Ideal for Single Alkaline Cell operations
- Maximum Output Current up to 1A
- Low Noise PWM control
- Internally Compensated Current Mode Control
- Internal Synchronous Rectifier
- Logic Control Shutdown ($I_Q < 1\mu A$)
- Available in SOT23-5

Applications

- One to Three Cell Battery Operated Devices
- Medical Instruments
- Bluetooth Headsets
- Flash-Based MP3 Players
- Noise Canceling Headphones



ACE710C

1A Synchronous PWM Boost converter

Absolute Maximum Ratings

Parameter		Value
SW Voltage		-0.3V~6V
EN,OUT Voltage		-0.3V~6V
Max Operating Junction Temperature(Tj)		125°C
Maximum Power Dissipation	SOT-23-5	450mW
Ambient Temperature(Ta)		-40~85°C
Storage Temperature(Ts)		-55~150°C
Lead Temperature & Time		260°C,10S

Note: Exceed these limits to damage to the device.

Exposure to absolute maximum rating conditions may affect device reliability.

Packaging Type

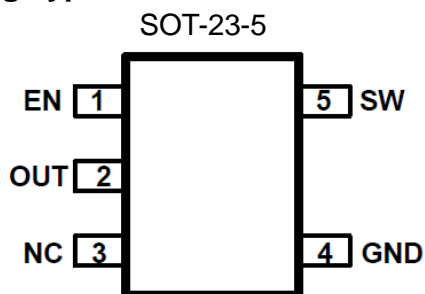

PIN #	NAME	DESCRIPTION
1	EN	Enable pin for the IC. Drive the pin to high to enable the part, and low to disable
2	OUT	Output voltage pin, with 10uF ceramic capacitor closely connected to GND
3	NC	No connection
4	GND	Ground
5	SW	To connect inductor to VIN



ACE710C

1A Synchronous PWM Boost converter

Ordering information

ACE710C XX XX + H

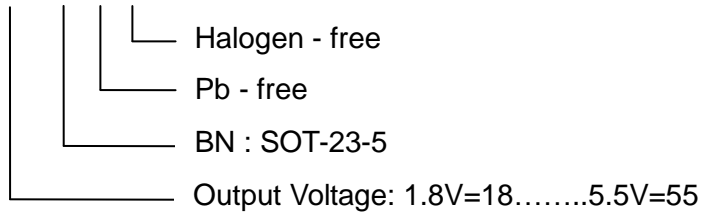

Typical Application

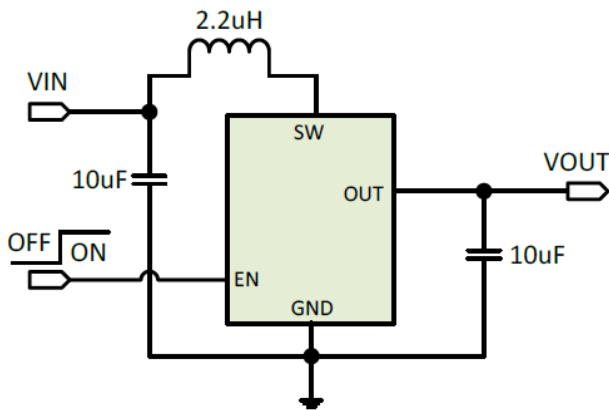

Block Diagram

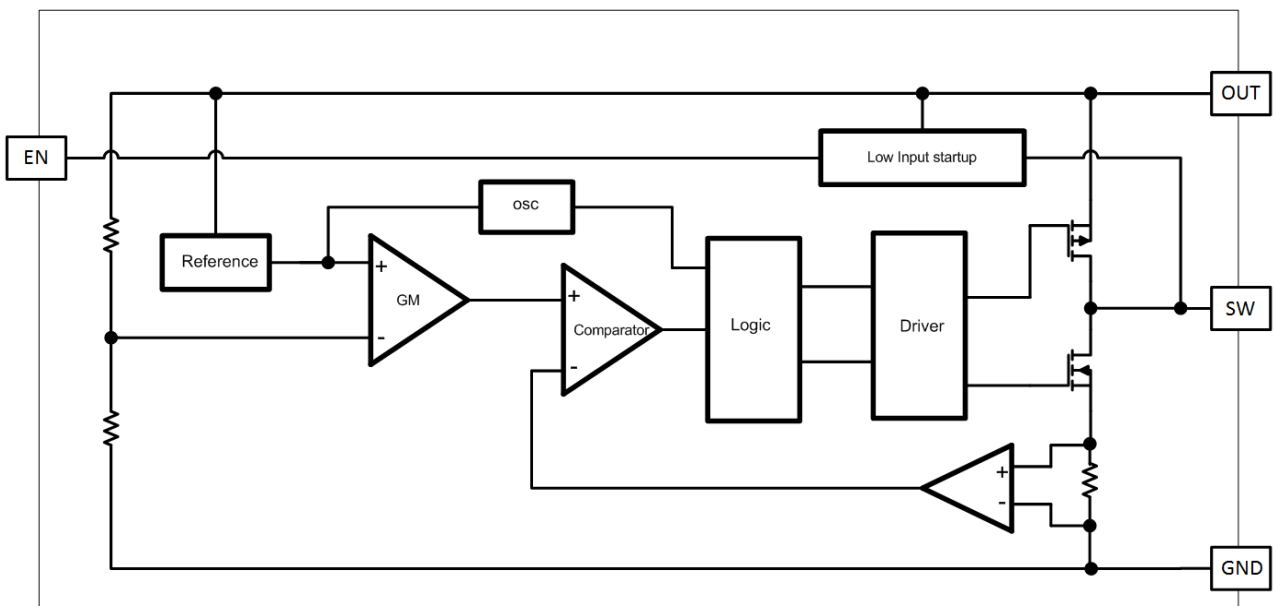



ACE710C

1A Synchronous PWM Boost converter

Electrical Characteristics

$T_A=25^{\circ}\text{C}$

Symbol	Parameter	Test Conditions	Min	Typ	Max	Unit
Vin	Input Voltage Range		0.9		5	V
Vstart	Startup Voltage	Iout = 1mA		0.9		V
Vhold	Hold Voltage	Iout = 50mA		0.5	0.7	V
Vout	Output Voltage Range		1.8		5.5	V
	Output voltage accuracy	Iout = 0mA		2		%
	Line regulation	Iout = 50mA		0.1	0.2	%/V
	Load regulation	Iout = 0~300mA		1	2	%
Fsoc	Switching Frequency	Vout=0.95Vo, No inductor	0.7	1	1.4	MHz
	Max Duty cycle	Vout=0.95Vo, No inductor	85	90	95	%
IQ	Quiescent Current at Vout	Vout=1.05*Vo	5	8	15	uA
	Supply current at Vin	Iout = 0mA			20	uA
	Shutdown Supply Current at Vin	EN=0		0.1	1	uA
	Efficiency	Iout = 100mA	85			%
RdsonP	PMOS Rdson	Isw =100mA		200	300	mohm
RdsonN	NMOS Rdson	Isw =100mA		100	150	mohm
Iswlk	SW Leakage Current	Vout=5.2V, Vsw=0 or 5.2V,EN=0			1	uA
Vh_en	EN Input High Voltage		1			V
VI_en	EN Input Low Voltage				0.3	V



ACE710C

1A Synchronous PWM Boost converter

Typical Performance Characteristics

Test conditions: $C_{in} = C_{out} = 10\mu F$, $T_A = 25^\circ C$, unless otherwise specified.

Efficiency vs. Output Current
($V_{out} = 5V$)

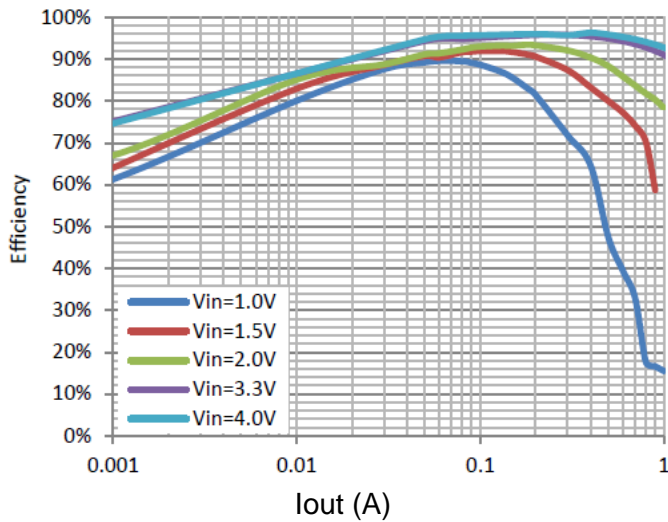

Efficiency vs. Output Current
($V_{out} = 3V$)

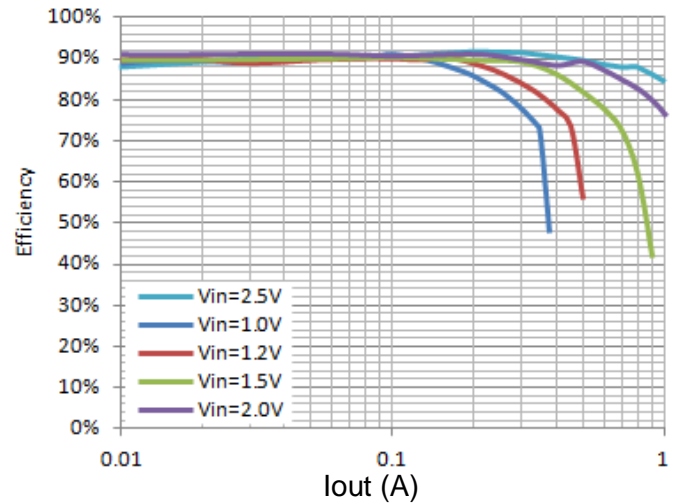

Output Voltage vs. Output Current
($V_{out} = 5V$)

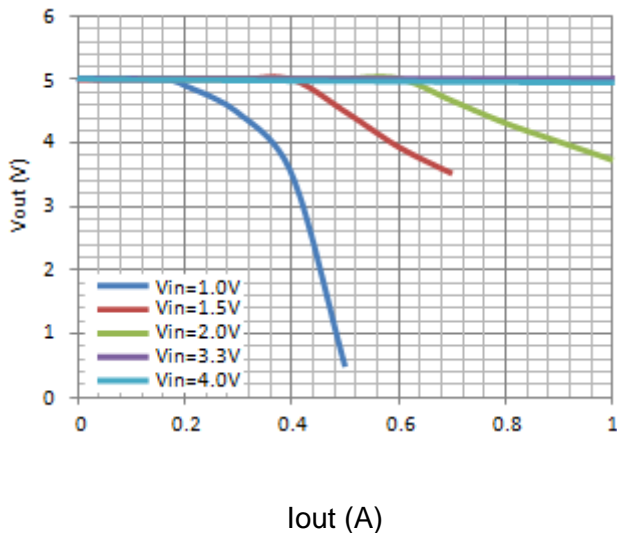

Output Voltage vs. Output Current
($V_{out} = 3V$)

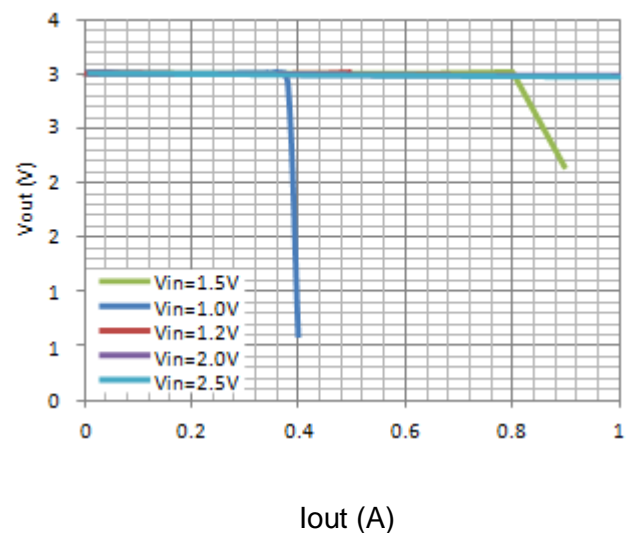



ACE710C

1A Synchronous PWM Boost converter

Detailed description

ACE710C is a low input voltage start up, current mode DC-DC step up converter. Its operation can be best understood by referring to the block diagram. Upon starting up, the low voltage startup circuitry drives SW with on-off cycles, transferring energy from input to OUT by storing energy in the inductor during on-time and releasing it to the output during off-time. When OUT is high enough, the startup circuit turns off and the main controller takes over. The main control loop consists of a reference, a GM error amplifier, a PWM controller, a current sense amplifier, an oscillator, a PWM logic control, and its power stage including its driver. The main control loop is a classic current mode control loop. The GM stage integrates the error between FB and REF, and its output is used to compare with a triangular wave which the summing result of the current sense amplifier output and a slope compensation voltage. The output of the comparator is used to drive the power stage to reach regulation.

APPLICATION INFORMATION

Inductor selection

With switching frequency up to 1MHz, small surface mount inductors can be used with values from 2.2uH to 4.7uH. For a given chosen inductor value and application conditions make sure the peak inductor current does not exceed the maximum current rating of the selected vendor's inductor.

Input and output capacitor selection

The ACE710C's bootstrap architecture allows the use of very small input capacitor. For applications that only need to drive small output load current, the input capacitor is optional, because once output is started up, the IC's is powered by OUT, a quiet power supply.

The output capacitor is used to stabilize the loop and provide ac current to the load. A low ESR ceramic cap with values from 2.2uF to 22uF can be used. Smaller value capacitors are generally cheaper with small footprints, while larger capacitor provides lower ripples and better transient load responses. Also, when extreme low startup voltage is needed, larger output capacitors are needed for the part to startup under heavy load condition.



ACE710C

1A Synchronous PWM Boost converter

Packing Information

SOT-23-5

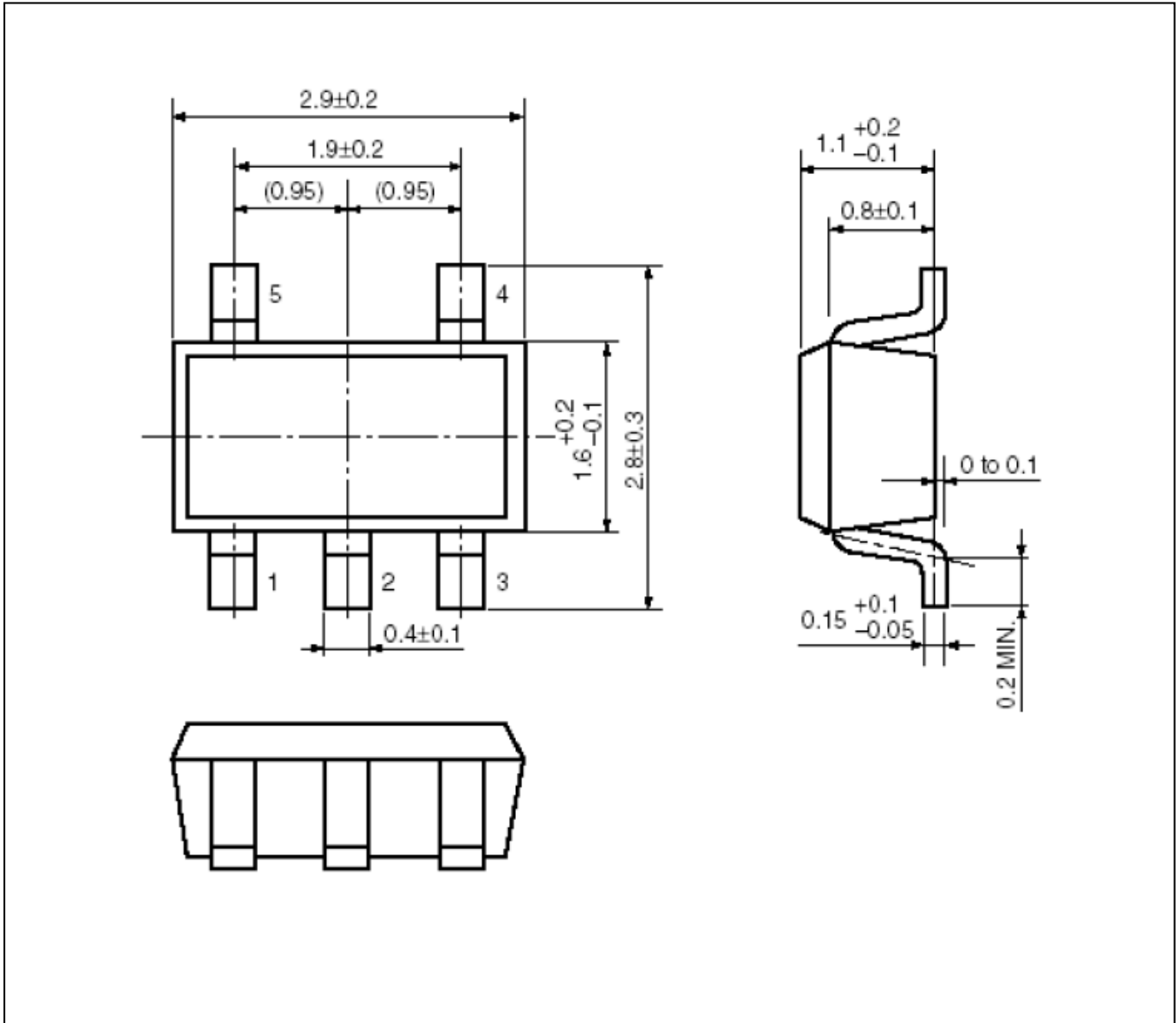



ACE710C

1A Synchronous PWM Boost converter

Notes

ACE does not assume any responsibility for use as critical components in life support devices or systems without the express written approval of the president and general counsel of ACE Electronics Co., LTD. As sued herein:

1. Life support devices or systems are devices or systems which, (a) are intended for surgical implant into the body, or (b) support or sustain life, and whose failure to perform when properly used in accordance with instructions for use provided in the labeling, can be reasonably expected to result in a significant injury to the user.
2. A critical component is any component of a life support device or system whose failure to perform can be reasonably expected to cause the failure of the life support device or system, or to affect its safety or effectiveness.

ACE Technology Co., LTD.
<http://www.ace-ele.com/>