

## Aerospace 1 x 20 and 2 x 20 A - 100 V Schottky rectifier

Datasheet - production data

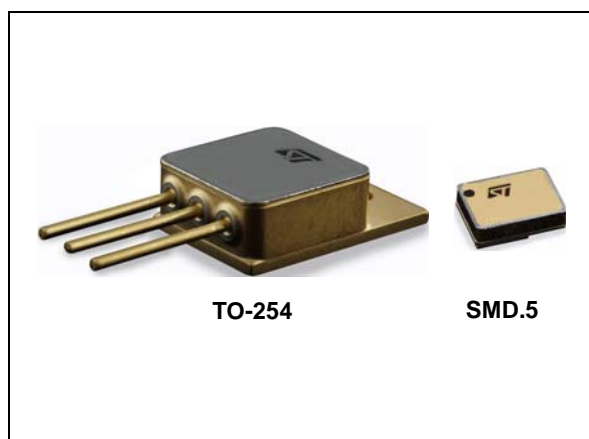

- High reverse avalanche surge capability
- Hermetic packages
- Target radiation qualification:
  - 150 krad (Si) low dose rate
  - 1 Mrad high dose rate
- ESCC qualified

### Description

This power Schottky rectifier is designed and packaged to comply with the ESCC5000 specification for aerospace products. Housed in hermetically sealed packages both surface mount and through hole, it is ideal for use in applications for aerospace and other harsh environments.

The STPS20100HR is intended for use in medium voltage application and particularly, in high frequency circuits where low switching losses and low noise are required.

### Features

- Forward current: 1 x 20 and 2 x 20 A
- Repetitive peak voltage: 100 V
- Low forward voltage drop: 0.8 V
- Maximum junction temperature: 175 °C
- Negligible switching losses
- Low capacitance

Table 1. Device summary

Order code	ESCC detailed specification	Quality level	Package	EPPL	IF (AV)	VRRM	T <sub>j</sub> (max)	VF (max)
STPS20100S1	-	Engineering model	SMD.5	-	1 x 20	100	175	1
STPS20100A2FY1	-	Engineering model	TO-254	-	2 x 20			
STPS20100C2FY1	-	Engineering model	TO-254	-	2 x 20			
STPS20100SG	5106/016/05	ESCC Flight	SMD.5	Yes	1 x 20			
STPS20100A2FYT	5106/016/02	ESCC Flight	TO-254	-	2 x 20			
STPS20100C2FYT	5106/016/03	ESCC Flight	TO-254	-	2 x 20			
STPS20100FYT	5106/016/01	ESCC Flight	TO-254	-	1 x 20			

# 1 Characteristics

**Table 2. Absolute maximum ratings**

Symbol	Characteristic	Value	Unit
$I_{FSM}$	Forward surge current (per diode) <sup>(1)</sup>	250	A
$V_{RRM}$	Repetitive peak reverse voltage <sup>(2)</sup>	100	V
$I_{RRM}$	Repetitive peak reverse current <sup>(3)</sup>	1	A
$I_O$	Average output rectified current (50% duty cycle): <sup>(4), (5)</sup>		
	All variants (per diode) Variants 02, and 03 (per device)	20 40	A
$I_{F(RMS)}$	Forward rms current (per diode)	30	A
$T_{OP}$	Operating temperature range <sup>(6)</sup> (case temperature)	-65 to +175	°C
$T_J$	Junction temperature	+175	°C
$T_{STG}$	Storage temperature range <sup>(6)</sup>	-65 to +175	°C
$T_{SOL}$	Soldering temperature:		
	For TO-254 <sup>(7)</sup> For SMD.5 <sup>(8)</sup>	+260 +245	°C
dV/dt	Critical rate of rise of reverse voltage	10000	V/μs

1. Sinusoidal pulse of 10 ms duration
2. Pulsed, duration 5 ms, F = 50 Hz
3. Pulsed, duration 2 μs, F = 1 kHz
4. For  $T_{case} > +140$  °C, derate linearly to 0 A at +175 °C.
5. The “per Device” ratings apply only as follows:  
Variant 02: when both cathode terminals are tied together  
Variant 03: when both anode terminals are tied together.
6. For variants with hot solder dip lead finish all testing performed at  $T_{amb} > +125$  °C are carried out in a 100% inert atmosphere.
7. Duration 10 seconds maximum at a distance of not less than 1.5 mm from the device body and the same lead shall not be resoldered until 3 minutes have elapsed.
8. Duration 5 seconds maximum and the same package shall not be resoldered until 3 minutes have elapsed.

**Table 3. Thermal resistance**

Symbol	Characteristic	Value	Unit
$R_{th(j-c)}$ <sup>(1)</sup>	Thermal resistance, junction to case		
	Variants 01, and 05	1.65	°C/W
	Variants 02 and 03 (per diode)	1.65	
Variants 02, and 03 (per device) <sup>(2)</sup>	0.85		

1. Package mounted on infinite heatsink
2. The per device ratings apply for variant 02 when both cathode terminals are tied together and for variant 03 when both anode terminals are tied together.

Table 4. Electrical measurements at ambient temperature (per diode),  $T_{amb} = 22 \pm 3 \text{ }^\circ\text{C}$ 

Symbol	Characteristic	MIL-STD-750 test method	Test conditions	Values		Units
				Min.	Max.	
$I_R$	Reverse Current	4016	DC method, $V_R = 100 \text{ V}$	-	30	$\mu\text{A}$
$V_{F1}^{(1)}$	Forward Voltage	4011	Pulse method, $I_F = 10 \text{ A}$	-	780	mV
$V_{F2}^{(1)}$			Pulse method, $I_F = 20 \text{ A}$	-	1	V
C	Capacitance	4001	$V_R = 10 \text{ V}$ , $F = 1 \text{ MHz}$	-	700	pF
$Z_{th(j-c)}$	Relative thermal impedance, junction to case	3101	$I_H = 15 \text{ to } 40 \text{ A}$ , $t_H = 50 \text{ ms}$ $I_M = 50 \text{ mA}$ , $t_{md} = 100 \text{ }\mu\text{s}$	Calculate $\Delta V_F$		$^\circ\text{C/W}$

1. Pulse width  $\leq 680\mu\text{s}$ , Duty Cycle  $\leq 2\%$

Table 5. Electrical measurements at high and low temperatures (per diode)

Symbol	Characteristic	MIL-STD-750 test method	Test conditions	Values		Units
				Min.	Max.	
$I_R$	Reverse Current	4016	$T_{case} = +125 (+0, -5) \text{ }^\circ\text{C}$ DC method, $V_R = 100 \text{ V}$	-	20	mA
$V_{F2}^{(1)}$	Forward Voltage	4011	$T_{case} = +125 (+0, -5) \text{ }^\circ\text{C}$ pulse method, $I_F = 20 \text{ A}$	-	900	mV
			$T_{case} = -55 (+5, -0) \text{ }^\circ\text{C}$ pulse method, $I_F = 20 \text{ A}$	-	1.1	V

1. Pulse width  $\leq 680\mu\text{s}$ , Duty Cycle  $\leq 2\%$

## 2 Configurations

Figure 1. Available device configurations

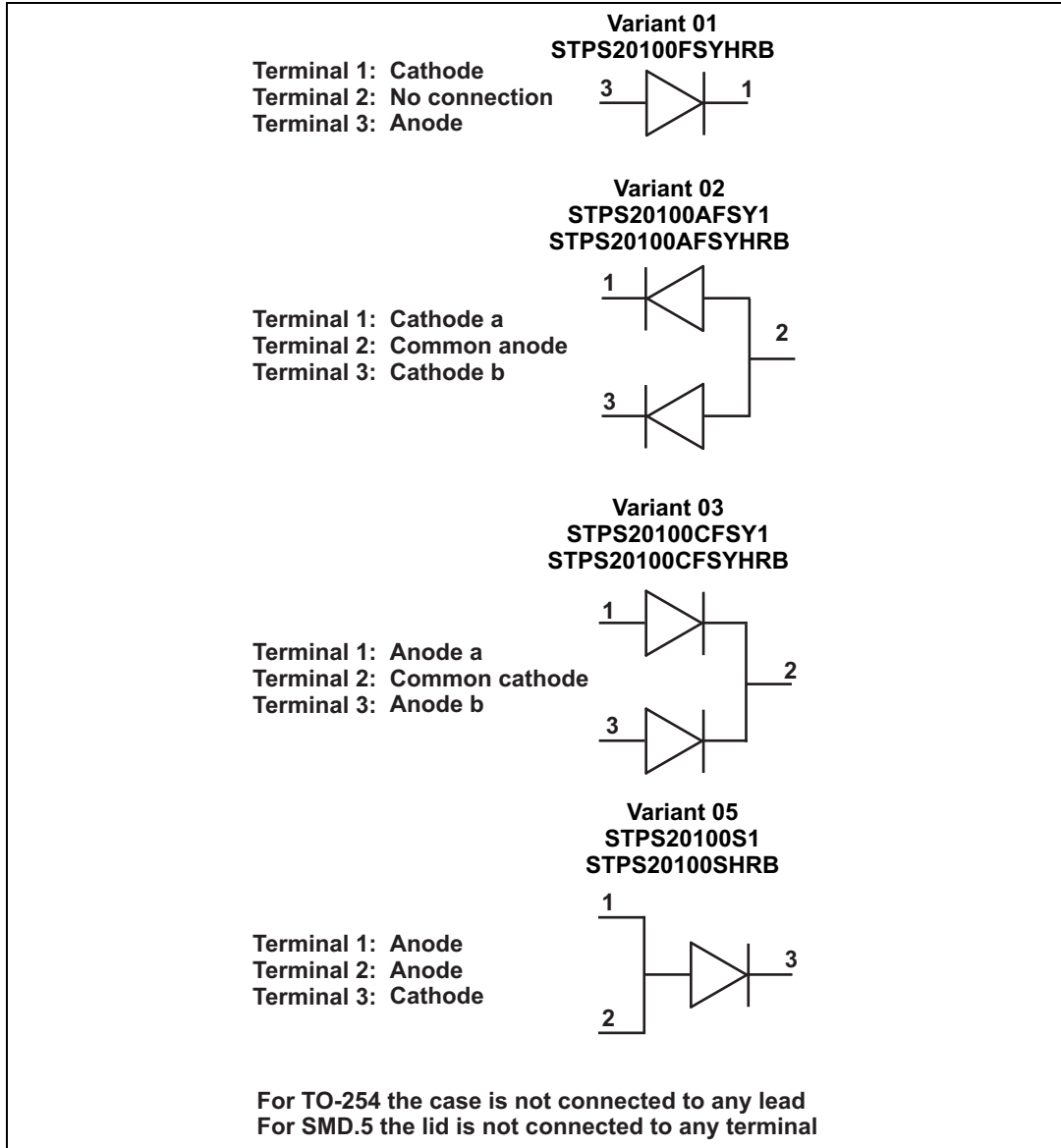

### 3 Package Information

In order to meet environmental requirements, ST offers these devices in different grades of ECOPACK® packages, depending on their level of environmental compliance. ECOPACK® specifications, grade definitions and product status are available at: [www.st.com](http://www.st.com). ECOPACK® is an ST trademark.

Figure 2. Metal flange mount package (TO-254<sup>(a)</sup>), 3 lead dimension definitions

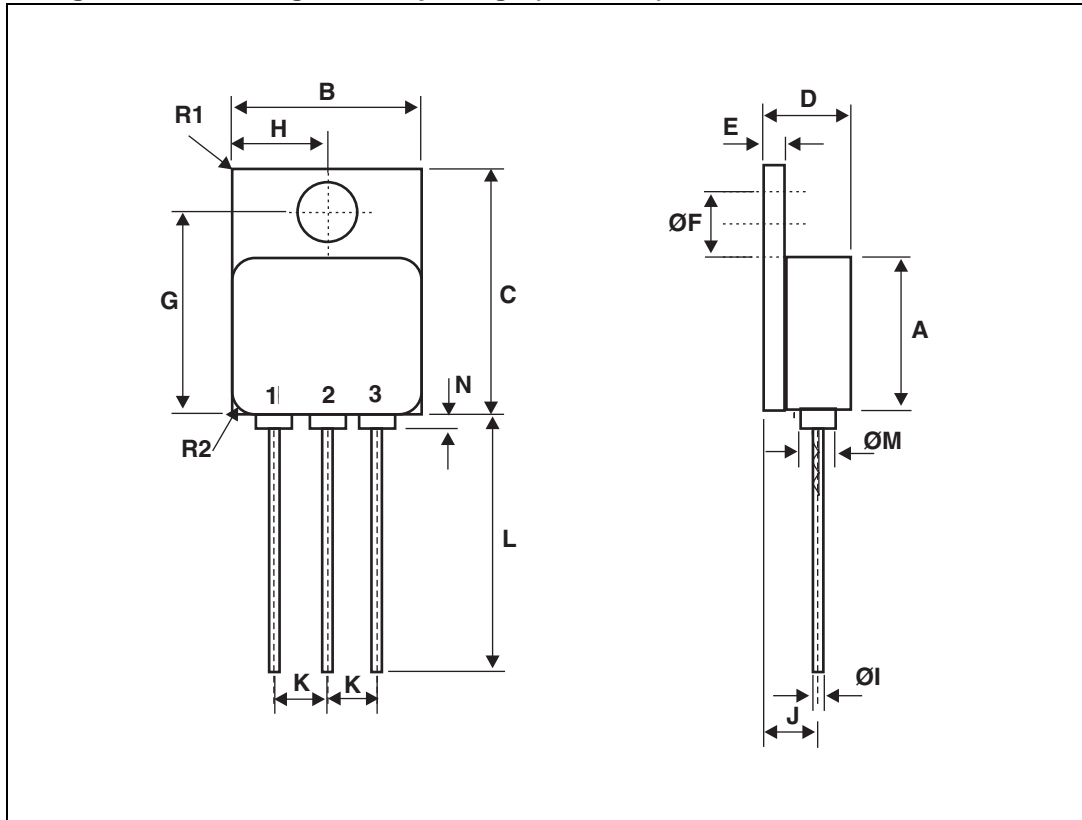

a. The terminal identification is specified by the device configuration. See [Figure 1](#) for terminal connections

Table 6. Metal flange mount package (TO-254), 3-lead dimension values

Reference	Dimension in millimetres		Dimension in inches	
	Min.	Max.	Min.	Max.
A	13.59	13.84	0.535	0.545
B	13.59	13.84	0.535	0.545
C	20.07	20.32	0.790	0.800
D	6.3	6.7	0.248	0.264
E	1	3.9	0.039	0.154
ØF	3.5	3.9	0.138	0.154
G	16.89	17.4	0.665	0.685
H	6.86 BSC		0.270 BSC	
ØI <sup>(1)</sup>	0.89	1.14	0.035	0.045
J	3.81 BSC		0.150 BSC	
K	3.81 BSC		0.150 BSC	
L	12.95	14.5	0.510	0.571
ØM	3.05 Typ.		0.120 Typ.	
N	-	0.71	-	0.028
R1 <sup>(2)</sup>	-	1	-	0.039
R2 <sup>(3)</sup>	1.65 Typ.		0.065	

1. 3 locations
2. Radius of heatsink flange corner - 4 locations
3. Radius of body corner - 4 locations

Figure 3. Surface mount package (SMD.5), 3-terminal dimension definitions

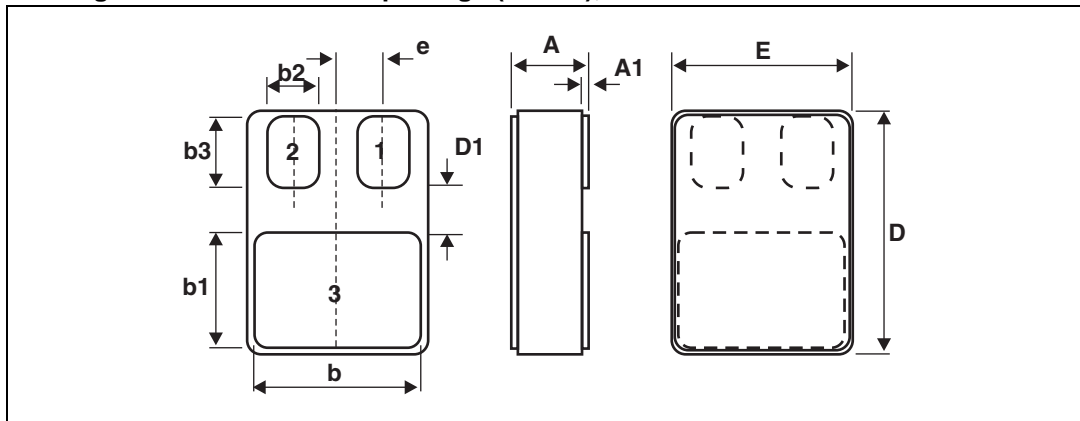

Table 7. Surface mount package (SMD.5), 3-terminal dimension values

Reference	Dimension in millimetres		Dimension in inches	
	Min.	Max.	Min.	Max.
A	2.84	3.15	0.112	0.124
A1	0.25	0.51	0.010	0.20
b	7.13	7.39	0.281	0.291
b1	5.58	5.84	0.220	0.230
b2 <sup>(1)</sup>	2.28	2.54	0.090	0.100
b3 <sup>(1)</sup>	2.92	3.18	0.115	0.125
D	10.03	10.28	0.395	0.405
D1 <sup>(1)</sup>	0.76	-	0.030	-
E	7.39	7.64	0.291	0.301
e <sup>(1)</sup>	1.91 BSC		0.075	

1. 2 locations

## 4 Ordering information

Table 8. Ordering information

Order code	ESCC detailed specification	Package	Lead finish	Comment	Marking <sup>(1)</sup>	Mass	EPPL	Packing
STPS20100S1	-	SMD.5	Gold	Single die	STPS20100S1	2	-	Strip pack
STPS20100A2FY1	-	TO-254	Gold	Double die - common anode	STPS20100AFY1 + BeO	10	-	
STPS20100C2FY1	-	TO-254	Gold	Double die - common cathode	STPS20100CFY1 + BeO	10	-	
STPS20100SG	5106/016/05	SMD.5	Gold	Single die	510601605	2	Yes	
STPS20100A2FYT	5106/016/02	TO-254	Solder Dip	Double die - common anode	510601602 +BeO	10	-	
STPS20100C2FYT	5106/016/03	TO-254	Solder Dip	Double die - common cathode	510601603 +BeO	10	-	
STPS20100FYT	5106/016/01	TO-254	Solder Dip	Single die	510601601 +BeO	10	-	

1. Specific marking only. The full marking includes in addition: For the engineering models: ST logo, date code, country of origin (FR). For ESCC flight parts: ST logo, date code, country of origin (FR), ESA logo, serial number of the part within the assembly lot.

## 5 Revision history

Table 9. Document revision history

Date	Revision	Changes
25-Mar-2010	1	Initial release.
19-Mar-2014	2	Updated <a href="#">Table 1: Device summary</a> , <a href="#">Table 8: Ordering information</a> and <a href="#">Figure 1: Available device configurations</a> .



**Please Read Carefully:**

Information in this document is provided solely in connection with ST products. STMicroelectronics NV and its subsidiaries ("ST") reserve the right to make changes, corrections, modifications or improvements, to this document, and the products and services described herein at any time, without notice.

All ST products are sold pursuant to ST's terms and conditions of sale.

Purchasers are solely responsible for the choice, selection and use of the ST products and services described herein, and ST assumes no liability whatsoever relating to the choice, selection or use of the ST products and services described herein.

No license, express or implied, by estoppel or otherwise, to any intellectual property rights is granted under this document. If any part of this document refers to any third party products or services it shall not be deemed a license grant by ST for the use of such third party products or services, or any intellectual property contained therein or considered as a warranty covering the use in any manner whatsoever of such third party products or services or any intellectual property contained therein.

**UNLESS OTHERWISE SET FORTH IN ST'S TERMS AND CONDITIONS OF SALE ST DISCLAIMS ANY EXPRESS OR IMPLIED WARRANTY WITH RESPECT TO THE USE AND/OR SALE OF ST PRODUCTS INCLUDING WITHOUT LIMITATION IMPLIED WARRANTIES OF MERCHANTABILITY, FITNESS FOR A PARTICULAR PURPOSE (AND THEIR EQUIVALENTS UNDER THE LAWS OF ANY JURISDICTION), OR INFRINGEMENT OF ANY PATENT, COPYRIGHT OR OTHER INTELLECTUAL PROPERTY RIGHT.**

**ST PRODUCTS ARE NOT DESIGNED OR AUTHORIZED FOR USE IN: (A) SAFETY CRITICAL APPLICATIONS SUCH AS LIFE SUPPORTING, ACTIVE IMPLANTED DEVICES OR SYSTEMS WITH PRODUCT FUNCTIONAL SAFETY REQUIREMENTS; (B) AERONAUTIC APPLICATIONS; (C) AUTOMOTIVE APPLICATIONS OR ENVIRONMENTS, AND/OR (D) AEROSPACE APPLICATIONS OR ENVIRONMENTS. WHERE ST PRODUCTS ARE NOT DESIGNED FOR SUCH USE, THE PURCHASER SHALL USE PRODUCTS AT PURCHASER'S SOLE RISK, EVEN IF ST HAS BEEN INFORMED IN WRITING OF SUCH USAGE, UNLESS A PRODUCT IS EXPRESSLY DESIGNATED BY ST AS BEING INTENDED FOR "AUTOMOTIVE, AUTOMOTIVE SAFETY OR MEDICAL" INDUSTRY DOMAINS ACCORDING TO ST PRODUCT DESIGN SPECIFICATIONS. PRODUCTS FORMALLY ESCC, QML OR JAN QUALIFIED ARE DEEMED SUITABLE FOR USE IN AEROSPACE BY THE CORRESPONDING GOVERNMENTAL AGENCY.**

Resale of ST products with provisions different from the statements and/or technical features set forth in this document shall immediately void any warranty granted by ST for the ST product or service described herein and shall not create or extend in any manner whatsoever, any liability of ST.

ST and the ST logo are trademarks or registered trademarks of ST in various countries.

Information in this document supersedes and replaces all information previously supplied.

The ST logo is a registered trademark of STMicroelectronics. All other names are the property of their respective owners.

© 2014 STMicroelectronics - All rights reserved

STMicroelectronics group of companies

Australia - Belgium - Brazil - Canada - China - Czech Republic - Finland - France - Germany - Hong Kong - India - Israel - Italy - Japan - Malaysia - Malta - Morocco - Philippines - Singapore - Spain - Sweden - Switzerland - United Kingdom - United States of America

[www.st.com](http://www.st.com)

