

CIRCUIT: SPDT

SWITCH FUNCTION		
PDS. 1	PDS. 2	PDS. 3
DN	NDNE	<DN>
2-3	DPEN	2-1

< >=Momentary

NOTES:

1. ALL DIMENSIONS IN MM [INCH]
2. GENERAL TOLERANCE: X.X=±0.4 X:XX=±0.25
3. TERM. NOS. FOR REF. ONLY
4. RATING: 5A @120V AC or 28V DC; 2A @250V AC
5. FIXED TERMINAL/MOVING CONTACT:  
Copper Alloy /w SILVER plate.  
Electrical Life: 50,000 make-and-break cycles at full load.
6. ELECTRICAL LIFE: 50,000 make-and-break cycles at full load.
7. INSULATION RESISTANCE: 1,000M ohm min.
8. DIELECTRIC STRENGTH: 1000V RMS @sea level
9. OPERATING TEMP.: -30°C to 85°C

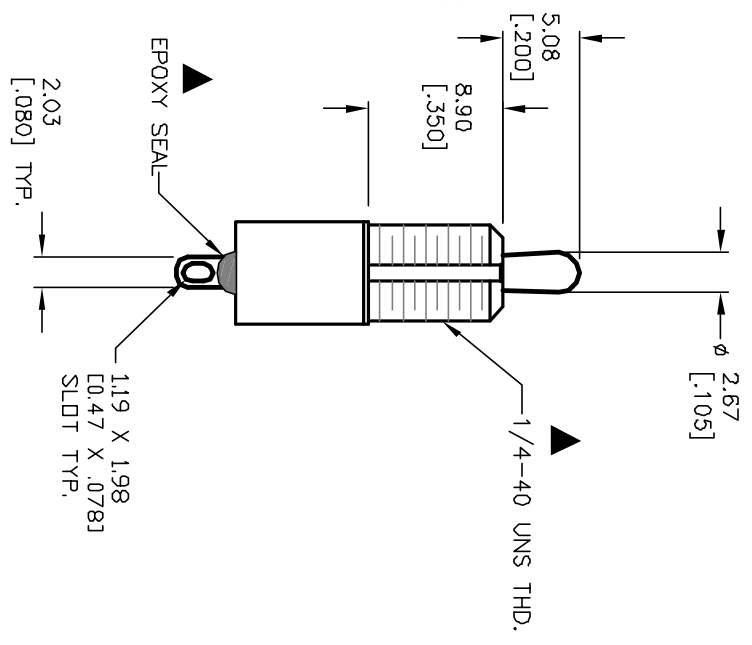
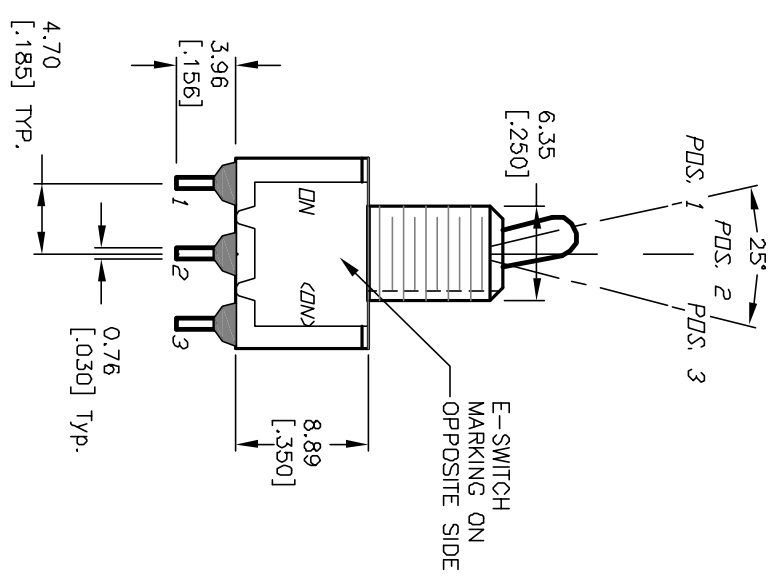
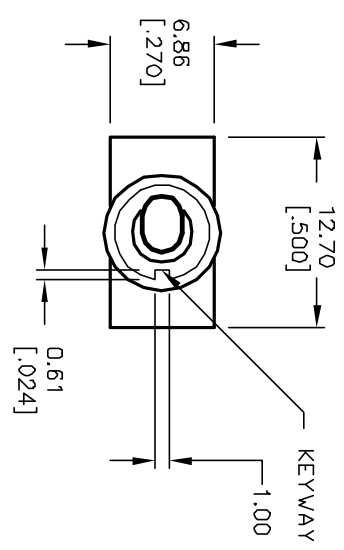

**E-SWITCH®**

REV.	ECN No.	DESCRIPTION	DATE	CHK'D
A	12166	RELEASED FOR PRODUCTION	5/20/02	CJB

TITLE	SCALE	DATE	DR	DWG	REV
100 SP-2 T2 B1 M1 Q E	2:1	5/20/02	CJB	T112019	A

THE INFORMATION CONTAINED IN THIS DOCUMENT IS PRELIMINARY AND IS NOT TO BE COPIED OR TRANSMITTED