

# Photon drag detector

B749



## High-speed detector with high sensitivity in the 10 μm band (for CO<sub>2</sub> laser detection)

The B749 is a photon drag detector that utilizes the photon drag effect in which carriers created by input photons are dragged in the direction of photons, generating an electromotive force. The B749 ensures high-speed operation even at room temperatures and has high sensitivity in the 10 μm band, making it well suited to detection of CO<sub>2</sub> lasers.

### Features

- Room temperature operation with high-speed response

### Applications

- CO<sub>2</sub> laser detection

### Options (sold separately)

- Magnet stand A1447

### Structure

Parameter	Specification	Unit
Photosensitive area	φ5	mm
Output polarity	Positive	-

### Absolute maximum ratings

Parameter	Symbol	Condition	Value	Unit
Operating temperature	T <sub>opr</sub>		0 to +60	°C
Storage temperature	T <sub>stg</sub>		0 to +60	°C
Incident light level	-	DC light	1	J/cm <sup>2</sup>
		Pulsed light	10	MW

Note: Exceeding the absolute maximum ratings even momentarily may cause a drop in product quality. Always be sure to use the product within the absolute maximum ratings.

### Electrical and optical characteristics (T<sub>a</sub>=25 °C)

Parameter	Symbol	Condition	Min.	Typ.	Max.	Unit
Photosensitivity	S	λ=10.6 μm	-	1.2	-	mV/kW
Rise time	tr	10 to 90%	-	-	1	ns
Noise equivalent power	NEP	λ=10.6 μm	-	4 × 10 <sup>-3</sup>	-	W/Hz <sup>1/2</sup>
Output impedance	-		-	50	-	Ω

### Precautions

The Ge element mounted in the detector package is susceptible to shocks and drop impacts. Handle the detector with extreme care. Do not allow light higher than 10 MW/cm<sup>2</sup> to strike the detector element, because the element surface might be damaged.

Dimensional outline (unit: mm, tolerance unless otherwise noted:  $\pm 1$ )

B749

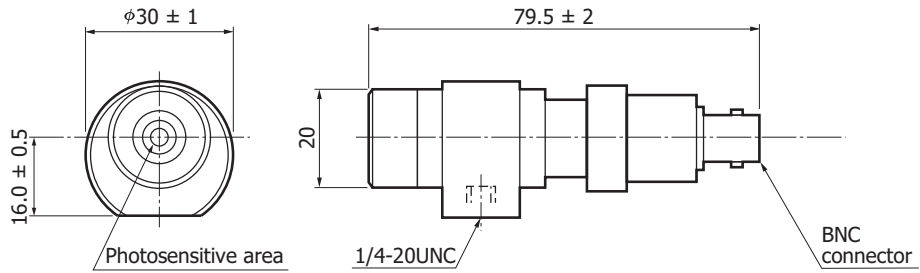

KIRDA0016ED

Magnet stand A1447 (sold separately)

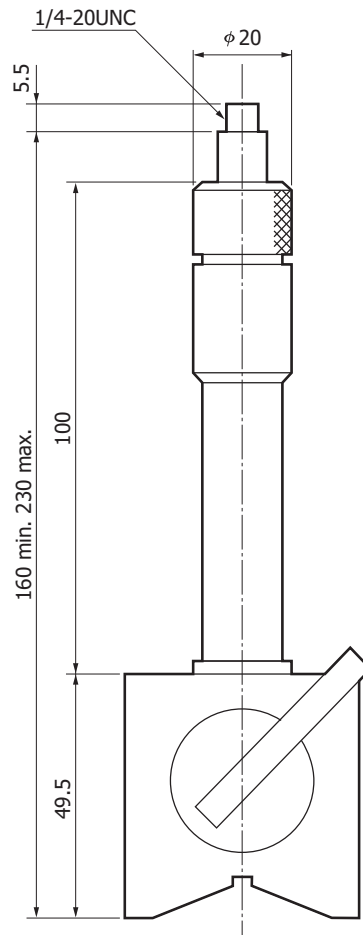

KIRDA0017EA

Information described in this material is current as of November, 2012.

Product specifications are subject to change without prior notice due to improvements or other reasons. Before assembly into final products, please contact us for the delivery specification sheet to check the latest information.

The product warranty is valid for one year after delivery and is limited to product repair or replacement for defects discovered and reported to us within that one year period. However, even if within the warranty period we accept absolutely no liability for any loss caused by natural disasters or improper product use.

Copying or reprinting the contents described in this material in whole or in part is prohibited without our prior permission.

**HAMAMATSU**[www.hamamatsu.com](http://www.hamamatsu.com)

HAMAMATSU PHOTONICS K.K., Solid State Division

1126-1 Ichino-cho, Higashi-ku, Hamamatsu City, 435-8558 Japan, Telephone: (81) 53-434-3311, Fax: (81) 53-434-5184

U.S.A.: Hamamatsu Corporation: 360 Foothill Road, P.O.Box 6910, Bridgewater, N.J. 08807-0910, U.S.A., Telephone: (1) 908-231-0960, Fax: (1) 908-231-1218

Germany: Hamamatsu Photonics Deutschland GmbH: Arzbergerstr. 10, D-82211 Herrsching am Ammersee, Germany, Telephone: (49) 8152-375-0, Fax: (49) 8152-265-8

France: Hamamatsu Photonics France S.A.R.L.: 19, Rue du Saule Trapu, Parc du Moulin de Massy, 91882 Massy Cedex, France, Telephone: 33-(1) 69 53 71 00, Fax: 33-(1) 69 53 71 10

United Kingdom: Hamamatsu Photonics UK Limited: 2 Howard Court, 10 Tewin Road, Welwyn Garden City, Hertfordshire AL7 1BW, United Kingdom, Telephone: (44) 1707-294888, Fax: (44) 1707-325777

North Europe: Hamamatsu Photonics Norden AB: Thorshamnsgatan 35 16440 Kista, Sweden, Telephone: (46) 8-509-031-00, Fax: (46) 8-509-031-01

Italy: Hamamatsu Photonics Italia S.R.L.: Strada della Moia, 1 int. 6, 20020 Arese, (Milano), Italy, Telephone: (39) 02-935-81-733, Fax: (39) 02-935-81-741

China: Hamamatsu Photonics (China) Co., Ltd.: 1201 Tower B, Jiaming Center, No.27 Dongsanhuan Beilu, Chaoyang District, Beijing 100020, China, Telephone: (86) 10-6586-6006, Fax: (86) 10-6586-2866