

AC/DC Drivers

AC/DC Controller IC for non-dimmable LED lighting

BD550FHG

●General Description

LED driver BD550FHG supports both isolated and non-isolated devices. IC enables simple design of low-power electrical converters.

With switching MOSFET and current detection resistor as external devices, it enables more freedom in design. Since the peak current control is utilized, peak current is controlled in each cycle, application excels wide bandwidth and transient response.

BD550FHG includes various protective functions such as soft start function, burst function, per-cycle over current limiter, VCC overvoltage protection and overload protection.

An external latch pin (COMP pin) is provided, so that latch stopping (OFF) can be set by external signals. This function is available as overheating protection and over output voltage protection.

The PWM switching frequency is fixed at 65 kHz.

A frequency hopping function is included which contributes to low EMI.

●Features

- PWM frequency of 65kHz
- PWM current mode method
- Low circuit current when UVLO is ON (12μA at VCC=12V)
- Low circuit current without load (Burst operation when load is light)
- Built-in SW frequency hopping function
- 250nsec leading-edge blanking
- VCC UVLO / OVP
- Per-cycle over current protection circuit
- Soft start
- Output overload protection (Self-restart protection)
- External latch function for COMP pin (Over heating protection function)

●Key Specifications

- Power Supply Voltage range: 8.5V to 25.0V
- Operating Current: Normal: 0.60mA (Typ)
Burst: 0.40mA (Typ)
- Oscillation Frequency: 65kHz (Typ)
- Operating Temperature range: -40°C to +110°C

●Package
SSOP6

W(Typ) x D (Typ) x H (Max)
2.90mm x 2.80mm x 1.25mm

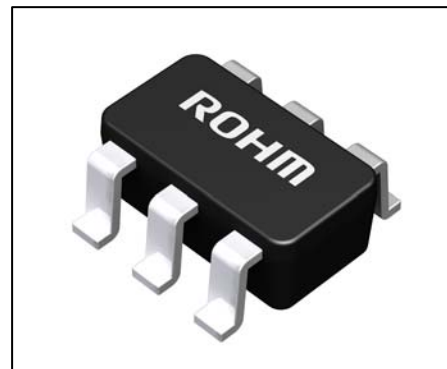

●Applications

- Electrical machineries for LED lighting

●Typical Application Circuit

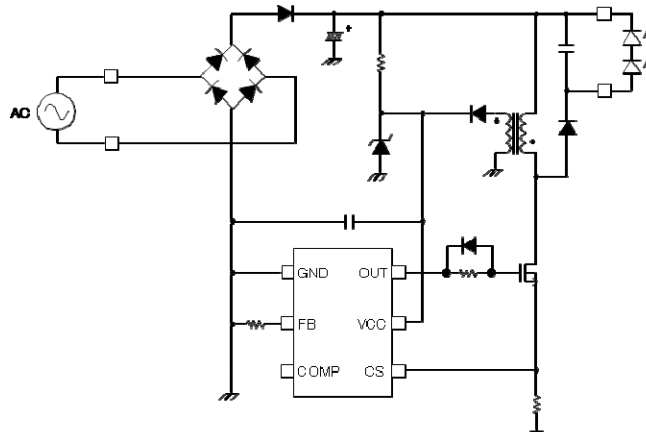

Figure 1, Application Diagram (Non-Isolated Type)

○Product structure : Silicon monolithic integrated circuit ○This product is not designed protection against radioactive rays

●Pin Configuration (SSOP6)

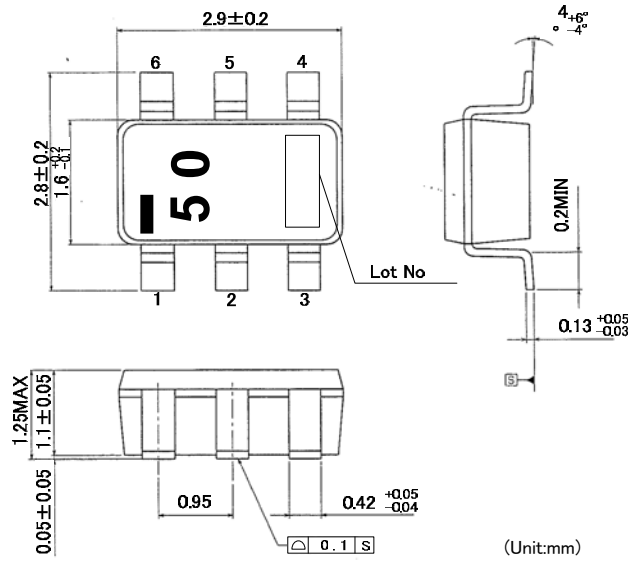

Figure 2, External Dimensions of SSOP6 Package

●Pin Description

Table 1 I/O PIN Functions

NO.	Pin Name	I/O	Function	ESD protection system	
				VCC	GND
1	GND	I/O	GND pin	○	-
2	FB	I	Feedback signal input pin	○	○
3	COMP	I	Comparator input pin	○	○
4	CS	I	Primary current sensor pin	○	○
5	VCC	I	Power supply input pin	-	○
6	OUT	O	External MOS drive pin	○	○

●I/O Equivalent Circuit

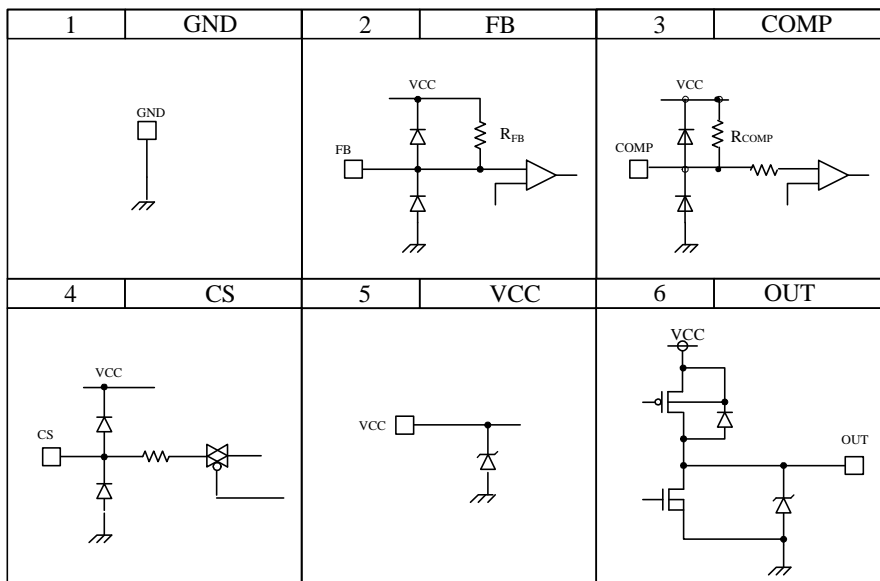

Figure 3, I/O Equivalent Circuit

●Block Diagram

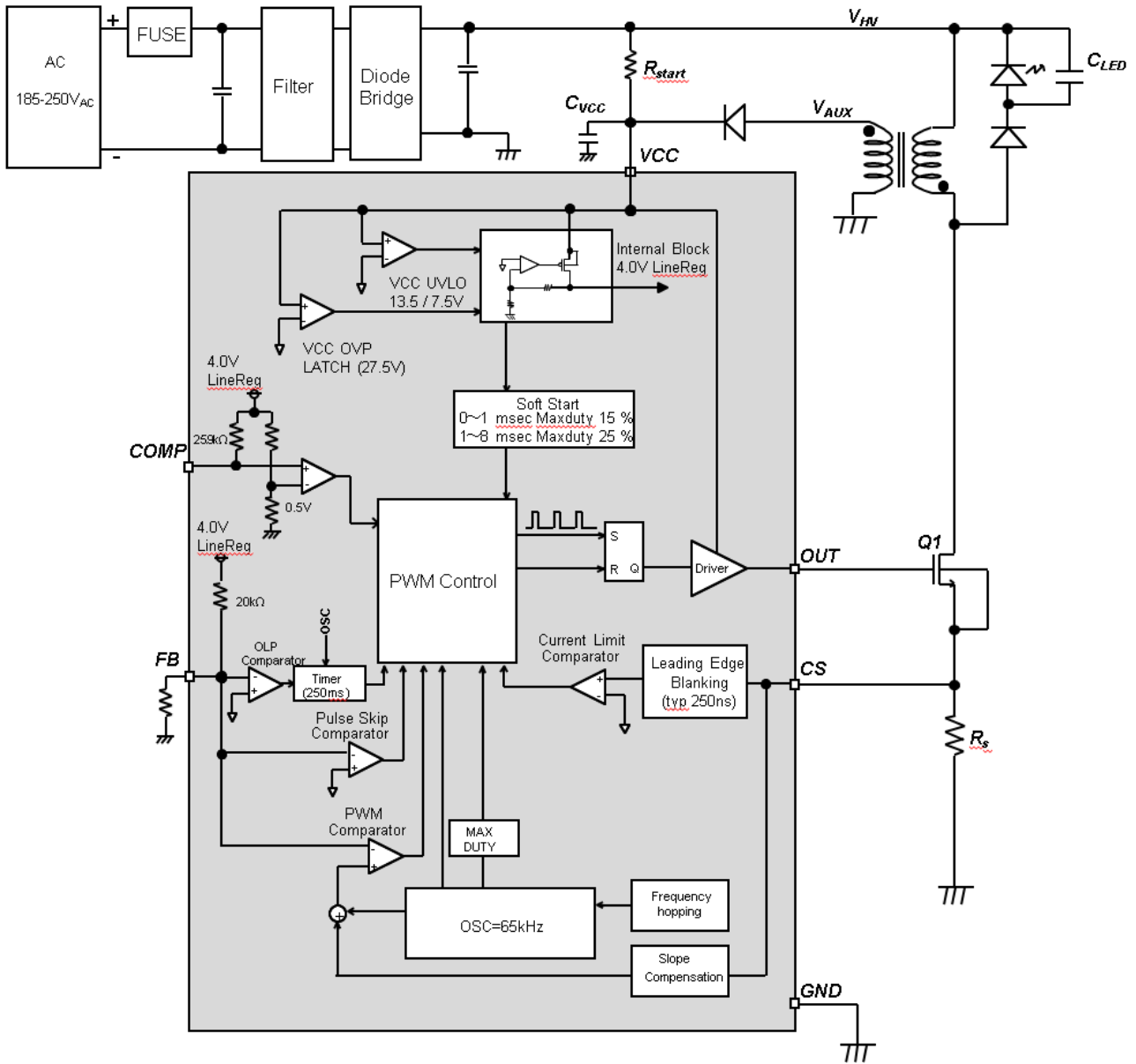

Figure 4, Block Diagram

●Description of Each Block

(1) Start Sequences (Soft Start Operation, Light Load Operation, and Overload Protection)

Start sequences are shown in Figure 5. This is also shown the operation of overload protection.

See the sections below for detailed descriptions

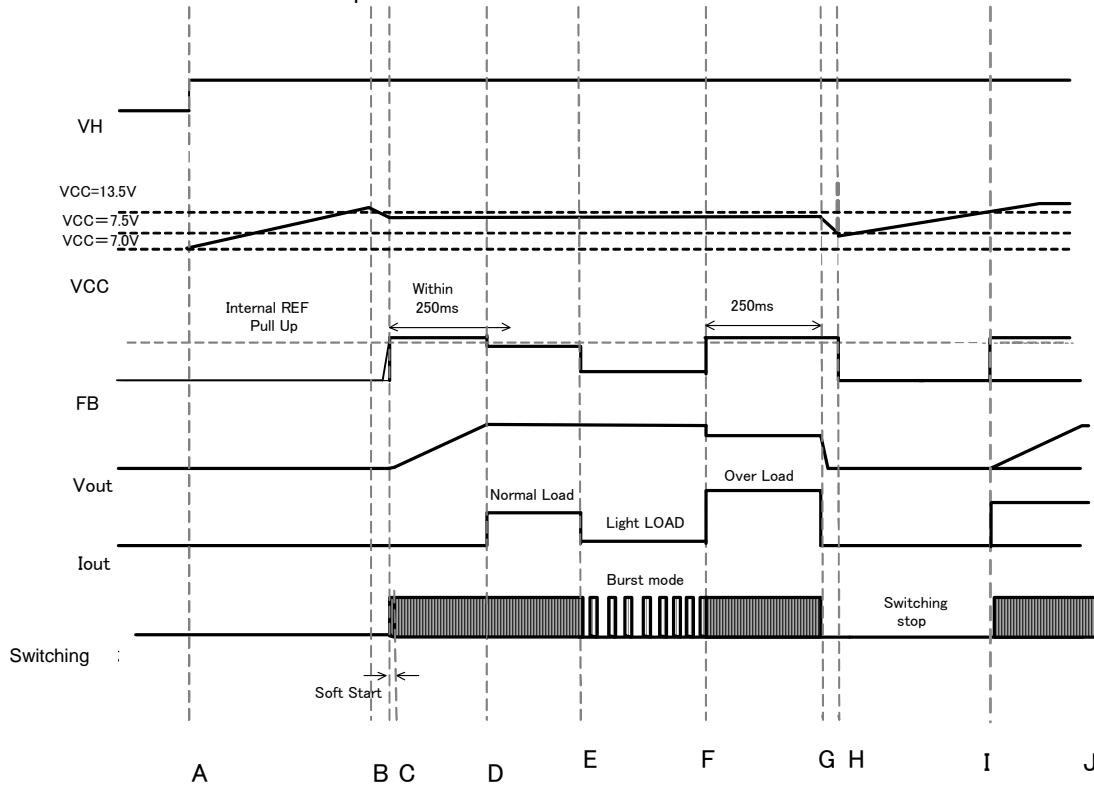

Figure 5, Start Sequence Timing Chart

A: Input voltage V_H is applied

B: VCC pin voltage rises by being supplied from V_H line through start resistor "Rstart" and the IC starts operating when $V_{CC} > V_{UVLO1}$ (13.5V Typ).

Switching operation starts when other protection functions are judged as normal.

From startup to be stable output voltage, application should be set to stabilize output voltage during $V_{CC} > V_{UVLO2}$ (7.5V Typ) because the VCC pin consumption current causes the VCC voltage drop.

C: Operated soft start function, maximum duty is restricted to 15% during a 1ms period to prevent any excessive rise in voltage or current. From 1ms to 8ms, maximum duty is restricted to 25%. Maximum duty is restricted to 75% after 8ms.

D: VOUT voltage rises when the switching operation starts.

Once the output voltage starts, it is set to the rated voltage level within the T_{FOLP} period (250ms Typ).

The output voltage is regulated within T_{FOLP} (=250ms Typ) from starting.

E: During Light Load, when FB pin voltage $< V_{BST}$ (=0.3V Typ), Burst method is operated to keep power consumption down.

F: Over Load condition occurs when FB pin voltage $> V_{FOLP1A}$ (=3.6V Typ).

G: When FB pin voltage is at V_{FOLP1A} (= 3.6V Typ) for more than T_{FOLP} (250ms Typ), the overload protection function is triggered and switching is stopped. The IC's internal 250ms timer is reset during the T_{FOLP} period (250ms Typ) if $FB < V_{FOLP1B}$ even once.

H: If the VCC voltage drops to V_{UVLO2} (7.5Vtyp) or below, restart is executed.

I: The IC's circuit current is reduced and the VCC pin value rises. (Same as B).

J: Same as D

In Figure 4, start resistor Rstart is needed to start the application.

When the start resistor Rstart value is reduced, standby power is increased and the startup time is shortened.

Conversely, when the start resistor Rstart value is increased, standby power is reduced and the startup time is lengthened. Standby current is less than 20uA at VCC UVLO is disable, and it can calculate VCC UVLO voltage from $V_{UVLO1}=14.5V$ (Max).

ex) Starting resistor Rstart setting method;

$$R_{start} = (V_{Hmin} - V_{UVLO1} (\text{Max})) / I_{OFF} (\text{Max})$$

In the case of $V_{ac}=100V$ (-20% of a margin), Rstart requirement can be found by the following formulas:

$$V_{Hmin} = 100 \times \sqrt{2} \times 0.8 = 113V$$

$$\text{Because of } V_{UVLO1} (\text{Max}) = 14.5V, R_{start} \leq (113V - 14.5V) / 20\mu A = 4.975M\Omega$$

Start-up time can be found by the following formulas:

$$T_{start} = -R_{start} \times C_{VCC} \times \ln(1 - V_{UVLO1}/V_{Hmin})$$

ex) $R_{start}=3.0M\Omega$

$$R_{start} \text{ resistor loss in this case is : } P_d (R_{start}) = (V_H - V_{CC})^2 / R_{start} = (141V - 14.5V)^2 / 3.0M = 5.35mW.$$

(2) VCC Pin Protection

BD550FHG includes UVLO (Under Voltage Locked Out) and OVP (Over Voltage Protection) functions to monitor VCC pin voltage (see Figure 6 for OVP latch operation).

The UVLO function prevents damage to MOSFET by stopping switching operations by latch protection when the VCC pin voltage drops to $V_{CC} < V_{UVLO2} (= 7.5V \text{ Typ})$.

The VCC OVP function prevents damage to MOSFET by stopping switching operations when the VCC pin voltage exceeds $V_{OVP1} (= 27.5V \text{ Typ})$.

The latch release condition is when $V_{CC} < V_{LATCH} (V_{UVLO2} - 0.5V, \text{ Typ} = 7.0V)$. A latch blanking time is used for protecting mal-function. This time is 100us.

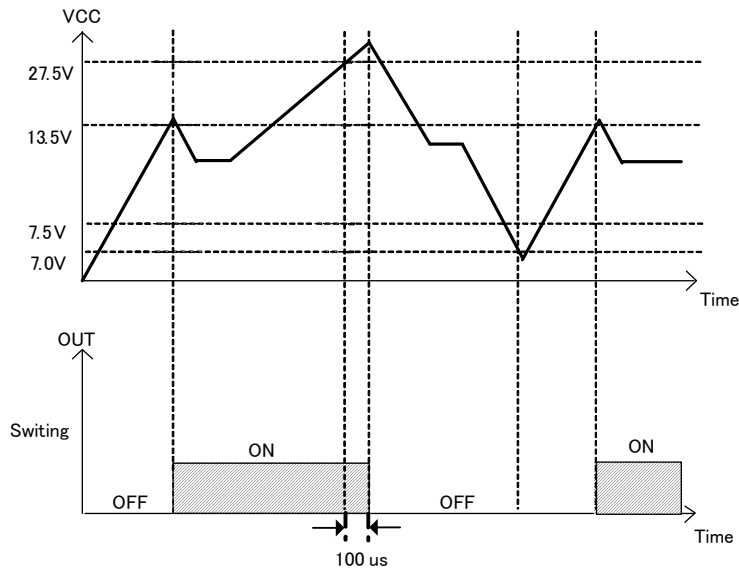

Figure 6, VCC UVLO/OVP Operation (Latch)

(3) DCDC Driver (PWM Comparator, Frequency Hopping, Slope Compensation, OSC, Burst)

BD550FHG uses current mode PWM control. In the internal generator, the average switching frequency is 65 kHz. Furthermore, switching frequency hopping function is built-in while the switching frequency fluctuation is shown as in Figure 7. Fluctuation cycle is 125Hz (=8ms).

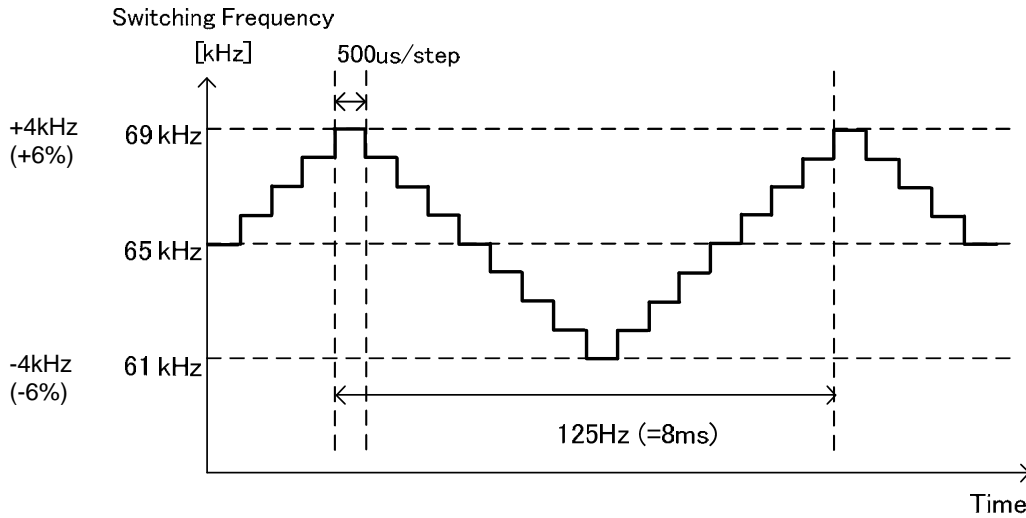

Figure 7, Frequency Hopping Function

The max-duty cycle is fix to 75% (Typ) at OUT pin and minimum pulse width is fix at 500ns (Typ). When the duty cycle exceeds 50% at Current Mode control, the sub-harmonic oscillation occurs. To prevent it, IC is built-in slope compensation function.

BD550FHG has burst mode function to attain less power consumption when load is light. This function monitors FB pin voltage and detects light load when FB voltage < V_{BST} (=0.3V Typ).

The secondary output voltage, the FB voltage and the DCDC function are shown in Figure 8.

FB pin is pulled up by R_{FB} (=20k Ω Typ). At light load, when the secondary output voltage rises, the FB pin voltage will drop and when this goes below V_{BST} (=0.3V Typ) burst function will follow to reduce the power consumption.

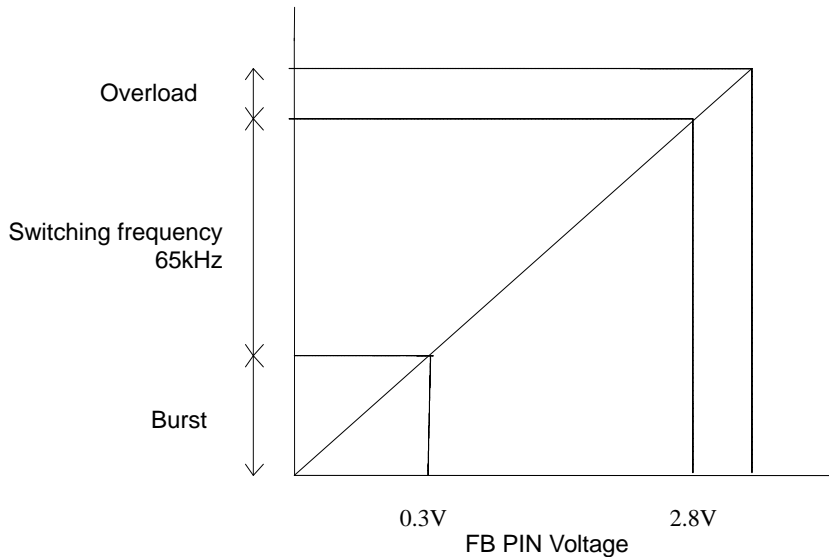

Figure 8, Switching Operation Status Changes by FB Pin Voltage

(4) Over Current Limiter and Leading Edge Blanking Period

BD550FHG has over current limiter for each switching cycle.

When the CS pin voltage exceeds the V_{CS} voltage ($=0.5V$ Typ), switching is turned OFF.

In addition, when the driver MOSFET is turned ON, surge current occurs at each capacitor component and drive current. Therefore, when the CS pin voltage rises temporarily, the detection errors may occur in the over current limiter circuit. To prevent detection errors, the OUT pin is switched from low to high and the CS signal is blanked for 250nsec by the LEB (Leading Edge Blanking) function. This blanking function enables a reduction of CS pin noise filtering in response to noise that occurs when the OUT pin is switched from low to high.

(5) Output Overload Protection Function (FB OLP Comparator)

Overload Protection Function monitors the load status of secondary output through FB pin and stops the switching of OUT pin during excessive load. In over load condition, there is no current in photo-coupler because output voltage decreases (drops) while FB pin voltage rises.

When FB pin voltage exceeds V_{FOLP1A} ($=3.6V$ Typ) at T_{FOLP} ($=250ms$ Typ) interval continuously, a load is excessive and OUT pin is fixed to L. The timer of overload protection is reset when FB pin drops further than V_{FOLP1B} ($=3.4V$ Typ) within T_{FOLP} ($=250ms$ Typ) after exceeding V_{FOLP1A} ($=3.6V$ Typ). Switching functions within this T_{FOLP} ($=250ms$ Typ).

FB voltage, which is pulled up in resistance to IC internal voltage operates from V_{FOLP1A} ($=3.6V$ Typ) or more at start-up. For this matter, set the start-up time of the secondary output voltage such that the FB voltage is always V_{FOLP1B} ($=3.4V$ Typ) or less within T_{FOLP} ($=250ms$ Typ) at start-up.

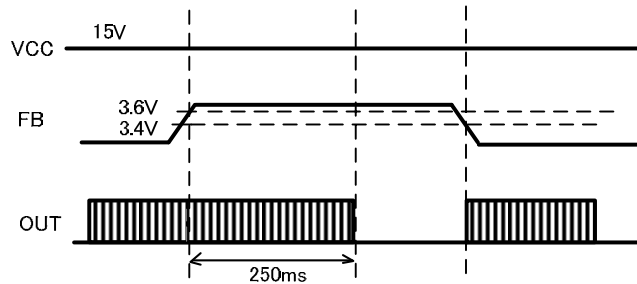

Figure 9, Overload Protection (Self-restart)

(6) COMP Pin External Latch Function

IC is latched when the COMP pin voltage goes below V_{LATCH} (0.5V Typ). A latch timer for T_{LATCH} (100us Typ) added to prevent operation errors caused by noise.

The COMP pin is pulled up by R_{LATCH} (25.9kΩ Typ), and when R_T (3.7kΩ Typ) is pulled down at the COMP pin, latch protection is operated. Some application examples are shown in Figure 10, Figure 11, and Figure 12.

Overheating Protection by NTC Thermistor

A thermistor is attached to the COMP pin so that latching can be stopped when overheating occurs.

In the case of this application, it should be designed so that the thermistor resistance becomes R_T (3.70kΩ Typ) when overheating is detected.

(Figure 10 and Figure 11 are application circuit examples in which latch operation occurs when $T_a = 110^{\circ}C$)

The variation in R_T (=3.70kΩ Typ) shown in an electrical property includes only IC.

Please add the variation of external thermistor resistance to it and design.

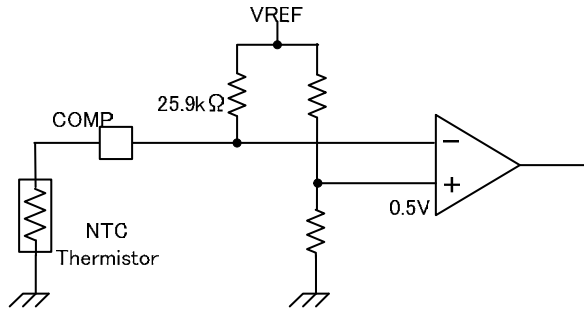

Figure 10, COMP Pin Overheating Protection Application

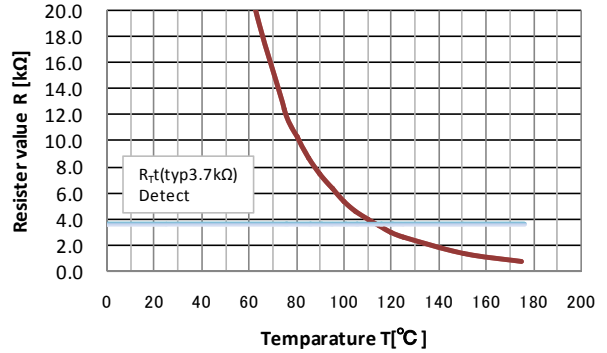

Figure 11, Temperature-Thermistor Resistance Value

● Absolute Maximum Ratings (Ta=25°C)

Parameter	Symbol	Rating	Unit	Conditions
Maximum Applied Voltage 1	Vmax1	30	V	VCC, OUT
Maximum Applied Voltage 2	Vmax2	6.5	V	CS, FB, COMP
OUT pin output Peak Current	I _{OUT}	±1.0	A	
Allowable Dissipation	Pd	674.9 (Note1)	mW	When implemented
Operating Temperature Range	Topr	-40 to +110	°C	
Storage Temperature Range	Tstr	-55 to +150	°C	

(Note1) SSOP6: Derate by 6.749 mW/°C when operating above Ta=25°C (when mounted on 70 mm x 70 mm, 1.6 mm thick, glass epoxy on single-layer substrate).

● Recommended Operating Ratings (Ta=25°C)

Parameter	Symbol	Rating	Unit	Conditions
Power Supply Voltage Range	VCC	8.5 to 26.0	V	VCC pin voltage

● Electrical Characteristics (Unless otherwise noted, Ta = 25°C, VCC=12V)

Parameter	Symbol	Specifications			Unit	Conditions
		MIN	TYP	MAX		
[Circuit Current]						
Circuit Current (OFF)	I _{OFF}	-	12	20	μA	VCC = 12V (UVLO = Detection)
Circuit Current (ON) 1	I _{ON1}	-	600	1000	μA	FB = 2.0V COMP: 100kΩ (during pulse operation)
Circuit Current (ON) 2	I _{ON2}	-	400	600	μA	FB = 0.0V COMP:100kΩ (during pulse operation)
[VCC Pin Protection Function]						
VCC UVLO Voltage 1	V _{UVLO1}	12.50	13.50	14.50	V	VCC rise
VCC UVLO Voltage 2	V _{UVLO2}	6.50	7.50	8.50	V	VCC drop
VCC UVLO Hysteresis	V _{UVLO3}	-	6.00	-	V	V _{UVLO3} = V _{UVLO1} - V _{UVLO2}
VCC OVP Voltage 1	V _{OVP1}	25.0	27.5	30.0	V	VCC rise

●Electrical Characteristics of control block (Unless otherwise noted, Ta = 25°C, VCC=12V)

Parameter	Symbol	Specifications			Unit	Conditions
		MIN	TYP	MAX		
[PWM Type DCDC Driver Block]						
Oscillation Frequency	F _{SW1}	60	65	70	KHz	FB=2.0V Typ frequency
Frequency Hopping Width 1	F _{DEL1}	-	4.0	-	KHz	FB=2.0V
Hopping Fluctuation Frequency	F _{CH}	93	125	157	Hz	
Minimum Pulse Width	T _{min}	-	500	-	ns	
Soft Start Time 1	T _{SS1}	0.75	1.00	1.25	ms	
Soft Start Time 2	T _{SS2}	6.00	8.00	10.00	ms	
Maximum Duty 1	D _{max}	68.0	75.0	82.0	%	During normal operation
Maximum Duty 2	D _{SS1}	5.0	15.0	25.0	%	During soft start 0[ms] to T _{SS1} [ms]
Maximum Duty 3	D _{SS2}	15.0	25.0	35.0	%	During soft start T _{SS1} [ms] to T _{SS2} [ms]
FB pin Pull-up Resistance	R _{FB}	15	20	25	kΩ	
FB / CS Rain	Gain	-	5	-	V/V	
FB Burst Voltage	V _{BST}	0.20	0.30	0.40	V	During FB drop
FB OLP Voltage 1a	V _{FOLP1A}	3.3	3.6	3.9	V	When overload is detected (FB rise)
FB OLP Voltage 1b	V _{FOLP1B}	-	$V_{FOLP1A} \cdot 0.5$	-	V	When overload is detected (FB drop)
FB OLP Timer	T _{FOLP}	187	250	312	ms	
Latch Release Voltage (VCC pin voltage)	V _{LATCH}	-	$V_{UVLO2} \cdot 0.5$	-	V	Latch release voltage VCCUVLO2-0.5 [V]
Latch Mask Time	T _{LATCH}	50	100	200	us	VCCOVP, COMP Mask time
[Overcurrent Detection Block]						
Overcurrent Detection Voltage	V _{CS}	0.475	0.500	0.525	V	
Leading Edge Blanking Time	T _{LEB}	-	250	-	ns	
[Output Driver Block]						
OUT pin Pch MOS Ron	R _{POUT}	10	25	39	Ω	
OUT pin Nch MOS Ron	R _{NOUT}	3	7	12	Ω	
[External Latch Comparator Block]						
COMP pin Latch Detection Voltage	V _{COMP}	-	0.5	-	V	
COMP pin Pull-up Resistance	R _{COMP}	-	25.9	-	kΩ	
Thermistor Resistance Detection Value	R _T	3.30	3.70	4.10	kΩ	Thermistor connected to COMP pin

● Typical Performance Curves

(This is not a guarantee since this is the reference data. Figure 36 shows the measurement circuit diagram.)

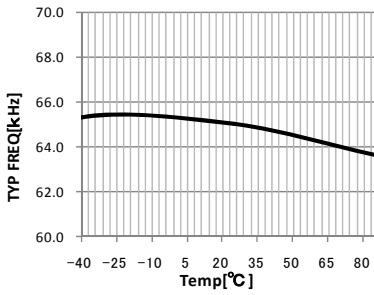

Figure 12, Typ Frequency Fsw1

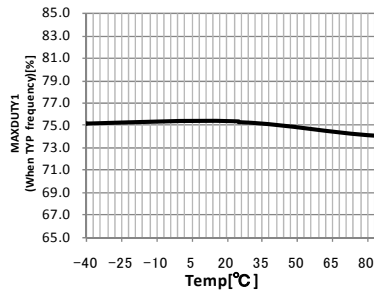

Figure 13, MAXDUTY1 (With Typ frequency)

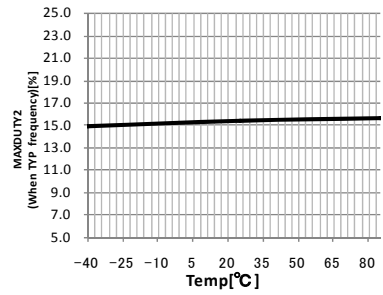

Figure 14, MAXDUTY2 (With Typ frequency)

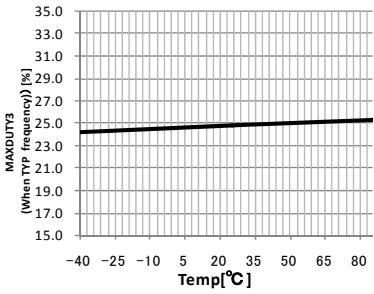

Figure 15, MAXDUTY3 (With Typ frequency)

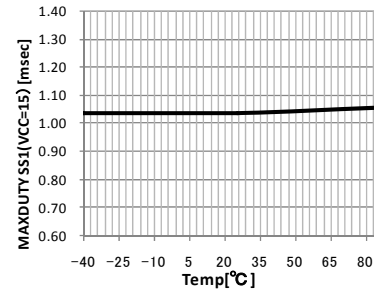

Figure 16, MAXDUTY SS1 (VCC=15)

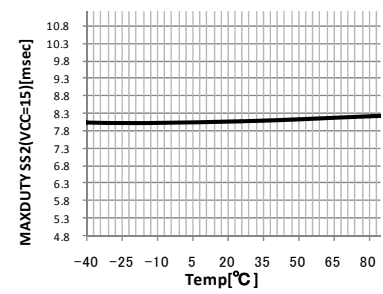

Figure 17, MAXDUTY SS2 (VCC=15)

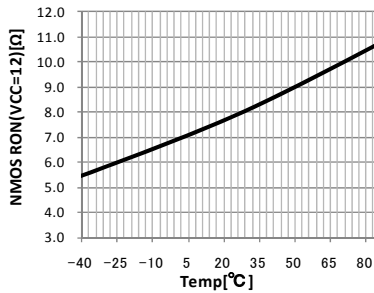

Figure 18, NMOS RON (VCC=12)

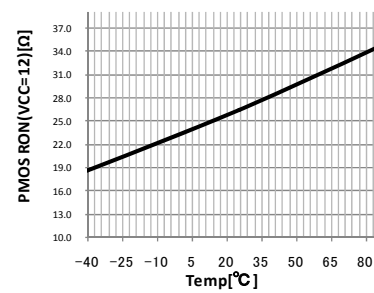

Figure 19, PMOS RON (VCC=12)

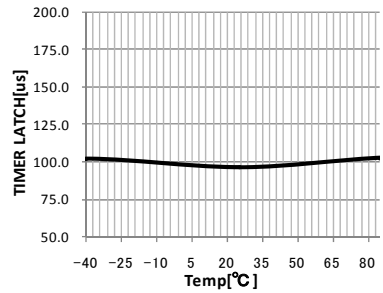

Figure 20, Timer Latch

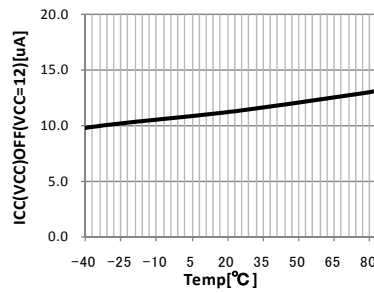

Figure 21, ICC (VCC) OFF (VCC=12)

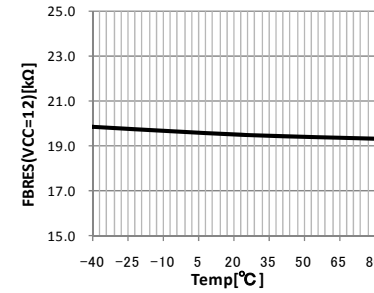

Figure 22, FBRES (VCC=12)

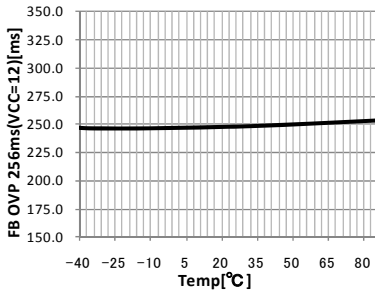

Figure 23, FB OVP 256ms(VCC=12)

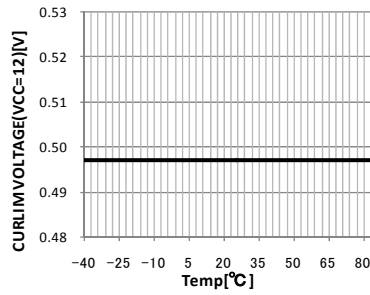

Figure 24, CURLIM Voltage (VCC=12)

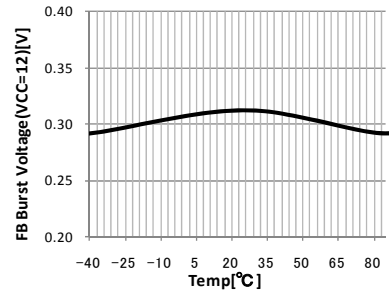

Figure 25, FB Burst Voltage (VCC=12)

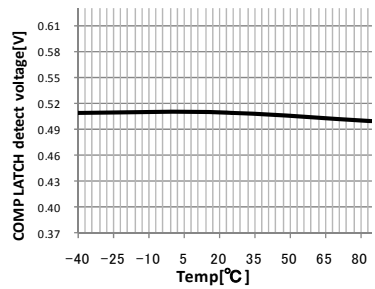

Figure 26, COMP Latch Detect Voltage

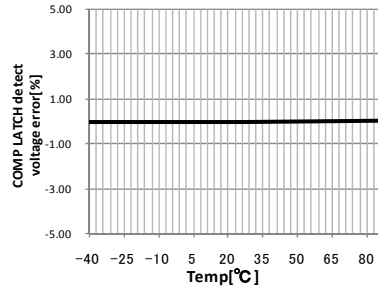

Figure 27, COMP Latch Detect Voltage Error

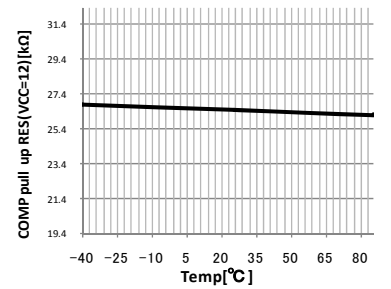

Figure 28, COMP Pull-up RES (VCC=12)

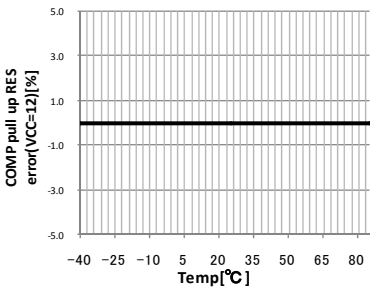

Figure 29, COMP Pull-up RES Error (VCC=12)

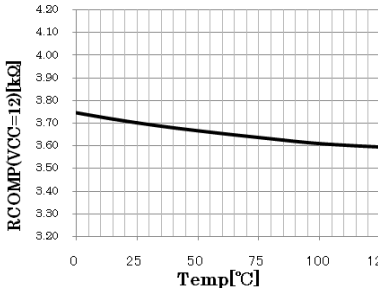

Figure 30, RCOMP (VCC=12)

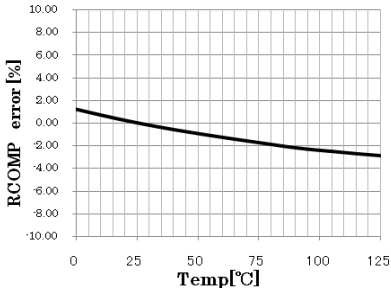

Figure 31, RCOMP Error

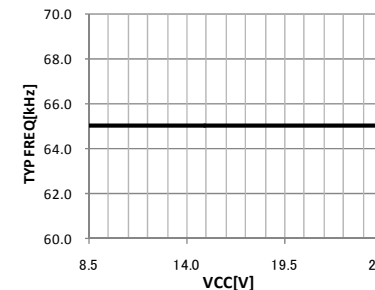

Figure 32, Typ Frequency Fsw1 (temp=25°C)

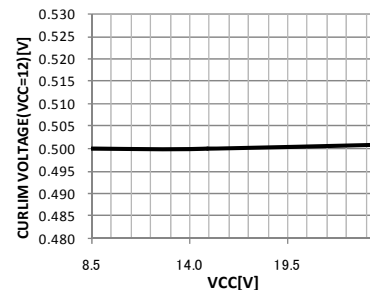

Figure 33, CURLIM Voltage (temp=25°C)

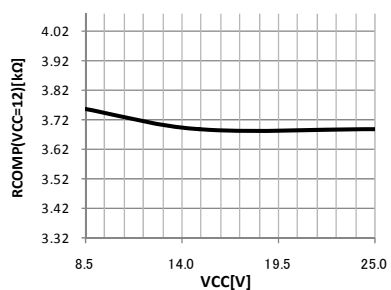

Figure 34, RCOMP (temp=25°C)

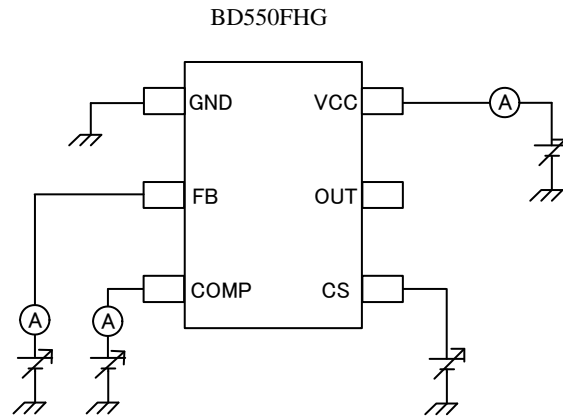

Figure 35, Measurement Circuit Diagram

● Power Dissipation

The thermal design should set the operation for the following conditions.
 (Since the temperature shown below is the guaranteed temperature, be sure to take margin into account.)

1. The ambient temperature T_a must be 110°C or less.
2. The IC's loss must be within the allowable dissipation P_d .

The thermal reduction characteristics are as follows.
 (PCB : 70mm×70mm×1.6mm mounted on glass epoxy substrate)

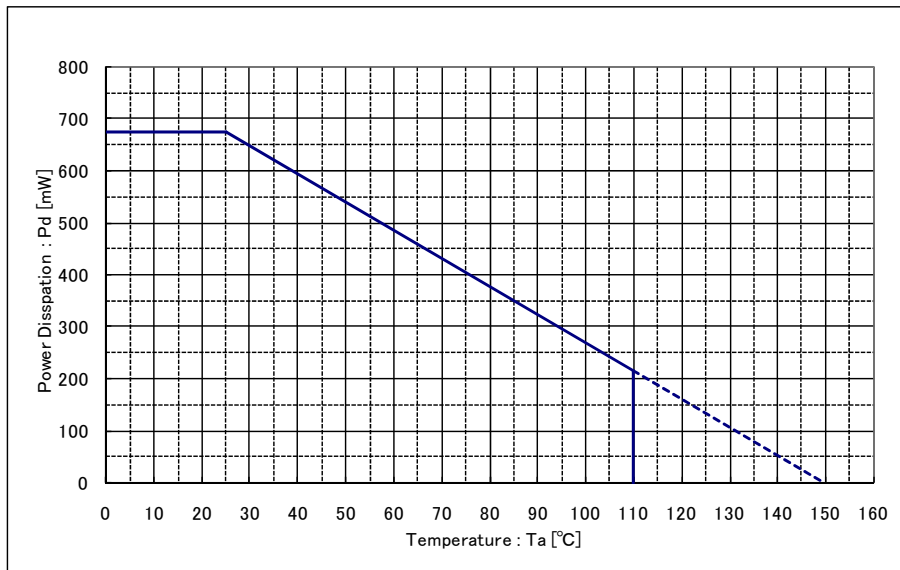

Figure 36, SSOP6 Thermal Reduction Characteristics

Operational Notes

1. Reverse Connection of Power Supply

Connecting the power supply in reverse polarity can damage the IC. Take precautions against reverse polarity when connecting the power supply, such as mounting an external diode between the power supply and the IC's power supply terminals.

2. Power Supply Lines

Design the PCB layout pattern to provide low impedance supply lines. Separate the ground and supply lines of the digital and analog blocks to prevent noise in the ground and supply lines of the digital block from affecting the analog block. Furthermore, connect a capacitor to ground at all power supply pins. Consider the effect of temperature and aging on the capacitance value when using electrolytic capacitors.

3. Ground Voltage

Ensure that no pins are at a voltage below that of the ground pin at any time, even during transient condition.

4. Ground Wiring Pattern

When using both small-signal and large-current ground traces, the two ground traces should be routed separately but connected to a single ground at the reference point of the application board to avoid fluctuations in the small-signal ground caused by large currents. Also ensure that the ground traces of external components do not cause variations on the ground voltage. The ground lines must be as short and thick as possible to reduce line impedance.

5. Thermal Consideration

Should by any chance the power dissipation rating be exceeded the rise in temperature of the chip may result in deterioration of the properties of the chip. The absolute maximum rating of the Pd stated in this specification is when the IC is mounted on a 70mm x 70mm x 1.6mm glass epoxy board. In case of exceeding this absolute maximum rating, increase the board size and copper area to prevent exceeding the Pd rating.

6. Recommended Operating Conditions

These conditions represent a range within which the expected characteristics of the IC can be approximately obtained. The electrical characteristics are guaranteed under the conditions of each parameter.

7. Rush Current

When power is first supplied to the IC, it is possible that the internal logic may be unstable and inrush current may flow instantaneously due to the internal powering sequence and delays, especially if the IC has more than one power supply. Therefore, give special consideration to power coupling capacitance, power wiring, width of ground wiring, and routing of connections.

8. Operation Under Strong Electromagnetic Field

Operating the IC in the presence of a strong electromagnetic field may cause the IC to malfunction.

9. Testing on Application Boards

When testing the IC on an application board, connecting a capacitor directly to a low-impedance output pin may subject the IC to stress. Always discharge capacitors completely after each process or step. The IC's power supply should always be turned off completely before connecting or removing it from the test setup during the inspection process. To prevent damage from static discharge, ground the IC during assembly and use similar precautions during transport and storage.

10. Inter-pin Short and Mounting Errors

Ensure that the direction and position are correct when mounting the IC on the PCB. Incorrect mounting may result in damaging the IC. Avoid nearby pins being shorted to each other especially to ground, power supply and output pin. Inter-pin shorts could be due to many reasons such as metal particles, water droplets (in very humid environment) and unintentional solder bridge deposited in between pins during assembly to name a few.

Operational Notes – continued

11. Unused Input Terminals

Input terminals of an IC are often connected to the gate of a MOS transistor. The gate has extremely high impedance and extremely low capacitance. If left unconnected, the electric field from the outside can easily charge it. The small charge acquired in this way is enough to produce a significant effect on the conduction through the transistor and cause unexpected operation of the IC. So unless otherwise specified, unused input terminals should be connected to the power supply or ground line.

12. Regarding the Input Pin of the IC

This monolithic IC contains P+ isolation and P substrate layers between adjacent elements in order to keep them isolated. P-N junctions are formed at the intersection of the P layers with the N layers of other elements, creating a parasitic diode or transistor. For example (refer to figure below):

When $GND > Pin A$ and $GND > Pin B$, the P-N junction operates as a parasitic diode.
When $GND > Pin B$, the P-N junction operates as a parasitic transistor.

Parasitic diodes inevitably occur in the structure of the IC. The operation of parasitic diodes can result in mutual interference among circuits, operational faults, or physical damage. Therefore, conditions that cause these diodes to operate, such as applying a voltage lower than the GND voltage to an input pin (and thus to the P substrate) should be avoided.

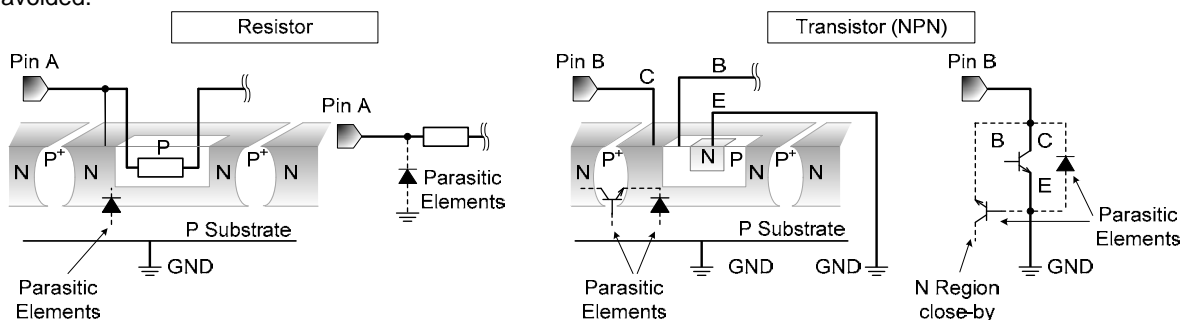

Figure xx. Example of monolithic IC structure

13. Ceramic Capacitor

When using a ceramic capacitor, determine the dielectric constant considering the change of capacitance with temperature and the decrease in nominal capacitance due to DC bias and others.

14. Area of Safe Operation (ASO)

Operate the IC such that the output voltage, output current, and power dissipation are all within the Area of Safe Operation (ASO).

15. Thermal Shutdown Circuit(TSD)

This IC has a built-in thermal shutdown circuit that prevents heat damage to the IC. Normal operation should always be within the IC's power dissipation rating. If however the rating is exceeded for a continued period, the junction temperature (T_j) will rise which will activate the TSD circuit that will turn OFF all output pins. When the T_j falls below the TSD threshold, the circuits are automatically restored to normal operation.

Note that the TSD circuit operates in a situation that exceeds the absolute maximum ratings and therefore, under no circumstances, should the TSD circuit be used in a set design or for any purpose other than protecting the IC from heat damage.

16. Over Current Protection Circuit (OCP)

This IC incorporates an integrated overcurrent protection circuit that is activated when the load is shorted. This protection circuit is effective in preventing damage due to sudden and unexpected incidents. However, the IC should not be used in applications characterized by continuous operation or transitioning of the protection circuit.

●Physical Dimension Tape and Reel Information

Package Name	SSOP6
--------------	-------

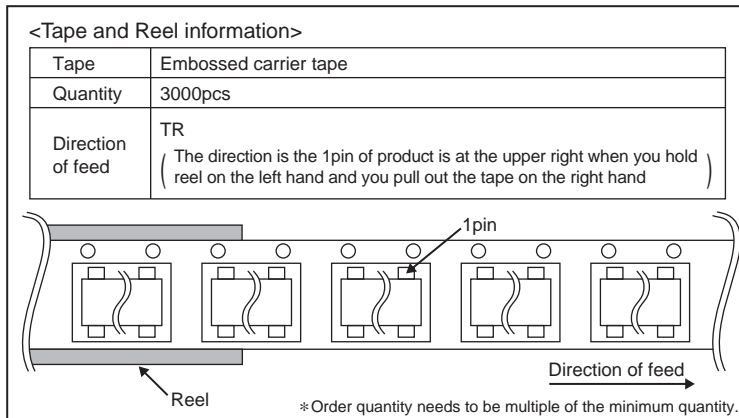
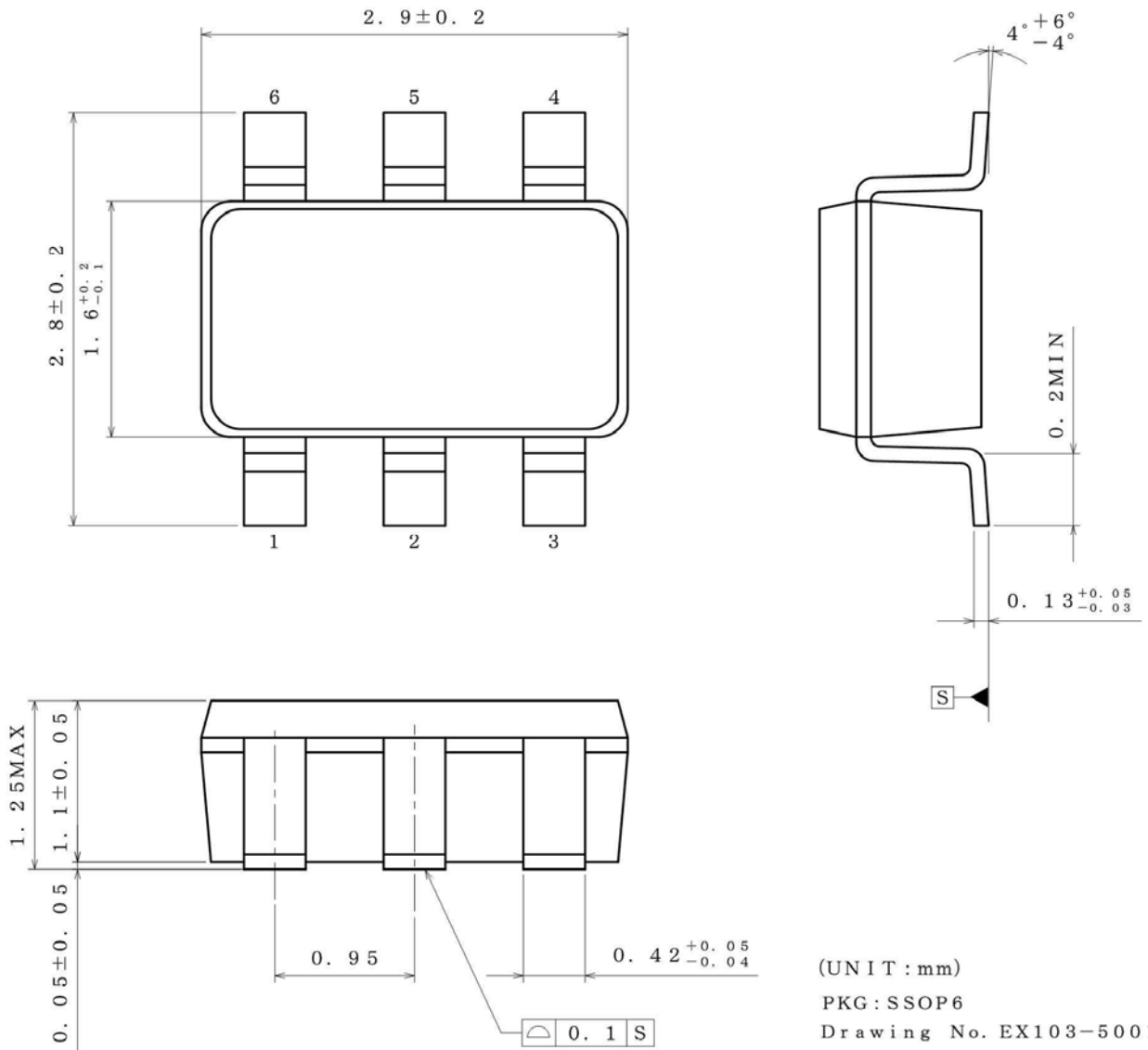

●Ordering Information

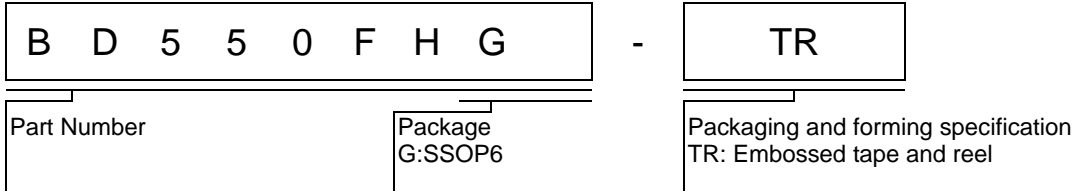

●Marking Diagram

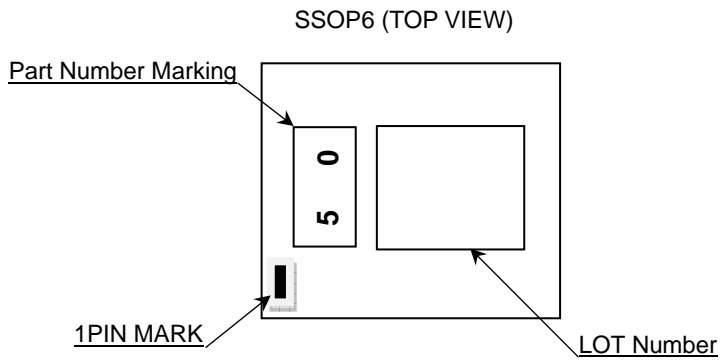

Notice

Precaution on using ROHM Products

- Our Products are designed and manufactured for application in ordinary electronic equipments (such as AV equipment, OA equipment, telecommunication equipment, home electronic appliances, amusement equipment, etc.). If you intend to use our Products in devices requiring extremely high reliability (such as medical equipment ^(Note 1), transport equipment, traffic equipment, aircraft/spacecraft, nuclear power controllers, fuel controllers, car equipment including car accessories, safety devices, etc.) and whose malfunction or failure may cause loss of human life, bodily injury or serious damage to property ("Specific Applications"), please consult with the ROHM sales representative in advance. Unless otherwise agreed in writing by ROHM in advance, ROHM shall not be in any way responsible or liable for any damages, expenses or losses incurred by you or third parties arising from the use of any ROHM's Products for Specific Applications.

(Note1) Medical Equipment Classification of the Specific Applications

JAPAN	USA	EU	CHINA
CLASS III	CLASS III	CLASS II b	CLASS III
CLASS IV		CLASS III	

- ROHM designs and manufactures its Products subject to strict quality control system. However, semiconductor products can fail or malfunction at a certain rate. Please be sure to implement, at your own responsibilities, adequate safety measures including but not limited to fail-safe design against the physical injury, damage to any property, which a failure or malfunction of our Products may cause. The following are examples of safety measures:
 - Installation of protection circuits or other protective devices to improve system safety
 - Installation of redundant circuits to reduce the impact of single or multiple circuit failure
- Our Products are designed and manufactured for use under standard conditions and not under any special or extraordinary environments or conditions, as exemplified below. Accordingly, ROHM shall not be in any way responsible or liable for any damages, expenses or losses arising from the use of any ROHM's Products under any special or extraordinary environments or conditions. If you intend to use our Products under any special or extraordinary environments or conditions (as exemplified below), your independent verification and confirmation of product performance, reliability, etc. prior to use, must be necessary:
 - Use of our Products in any types of liquid, including water, oils, chemicals, and organic solvents
 - Use of our Products outdoors or in places where the Products are exposed to direct sunlight or dust
 - Use of our Products in places where the Products are exposed to sea wind or corrosive gases, including Cl₂, H₂S, NH₃, SO₂, and NO₂
 - Use of our Products in places where the Products are exposed to static electricity or electromagnetic waves
 - Use of our Products in proximity to heat-producing components, plastic cords, or other flammable items
 - Sealing or coating our Products with resin or other coating materials
 - Use of our Products without cleaning residue of flux (even if you use no-clean type fluxes, cleaning residue of flux is recommended); or Washing our Products by using water or water-soluble cleaning agents for cleaning residue after soldering
 - Use of the Products in places subject to dew condensation
- The Products are not subject to radiation-proof design.
- Please verify and confirm characteristics of the final or mounted products in using the Products.
- In particular, if a transient load (a large amount of load applied in a short period of time, such as pulse. is applied, confirmation of performance characteristics after on-board mounting is strongly recommended. Avoid applying power exceeding normal rated power; exceeding the power rating under steady-state loading condition may negatively affect product performance and reliability.
- De-rate Power Dissipation (Pd) depending on Ambient temperature (Ta). When used in sealed area, confirm the actual ambient temperature.
- Confirm that operation temperature is within the specified range described in the product specification.
- ROHM shall not be in any way responsible or liable for failure induced under deviant condition from what is defined in this document.

Precaution for Mounting / Circuit board design

- When a highly active halogenous (chlorine, bromine, etc.) flux is used, the residue of flux may negatively affect product performance and reliability.
- In principle, the reflow soldering method must be used; if flow soldering method is preferred, please consult with the ROHM representative in advance.

For details, please refer to ROHM Mounting specification

Precautions Regarding Application Examples and External Circuits

1. If change is made to the constant of an external circuit, please allow a sufficient margin considering variations of the characteristics of the Products and external components, including transient characteristics, as well as static characteristics.
2. You agree that application notes, reference designs, and associated data and information contained in this document are presented only as guidance for Products use. Therefore, in case you use such information, you are solely responsible for it and you must exercise your own independent verification and judgment in the use of such information contained in this document. ROHM shall not be in any way responsible or liable for any damages, expenses or losses incurred by you or third parties arising from the use of such information.

Precaution for Electrostatic

This Product is electrostatic sensitive product, which may be damaged due to electrostatic discharge. Please take proper caution in your manufacturing process and storage so that voltage exceeding the Products maximum rating will not be applied to Products. Please take special care under dry condition (e.g. Grounding of human body / equipment / solder iron, isolation from charged objects, setting of ionizer, friction prevention and temperature / humidity control).

Precaution for Storage / Transportation

1. Product performance and soldered connections may deteriorate if the Products are stored in the places where:
 - [a] the Products are exposed to sea winds or corrosive gases, including Cl₂, H₂S, NH₃, SO₂, and NO₂
 - [b] the temperature or humidity exceeds those recommended by ROHM
 - [c] the Products are exposed to direct sunshine or condensation
 - [d] the Products are exposed to high Electrostatic
2. Even under ROHM recommended storage condition, solderability of products out of recommended storage time period may be degraded. It is strongly recommended to confirm solderability before using Products of which storage time is exceeding the recommended storage time period.
3. Store / transport cartons in the correct direction, which is indicated on a carton with a symbol. Otherwise bent leads may occur due to excessive stress applied when dropping of a carton.
4. Use Products within the specified time after opening a humidity barrier bag. Baking is required before using Products of which storage time is exceeding the recommended storage time period.

Precaution for Product Label

QR code printed on ROHM Products label is for ROHM's internal use only.

Precaution for Disposition

When disposing Products please dispose them properly using an authorized industry waste company.

Precaution for Foreign Exchange and Foreign Trade act

Since our Products might fall under controlled goods prescribed by the applicable foreign exchange and foreign trade act, please consult with ROHM representative in case of export.

Precaution Regarding Intellectual Property Rights

1. All information and data including but not limited to application example contained in this document is for reference only. ROHM does not warrant that foregoing information or data will not infringe any intellectual property rights or any other rights of any third party regarding such information or data. ROHM shall not be in any way responsible or liable for infringement of any intellectual property rights or other damages arising from use of such information or data.:
2. No license, expressly or implied, is granted hereby under any intellectual property rights or other rights of ROHM or any third parties with respect to the information contained in this document.

Other Precaution

1. This document may not be reprinted or reproduced, in whole or in part, without prior written consent of ROHM.
2. The Products may not be disassembled, converted, modified, reproduced or otherwise changed without prior written consent of ROHM.
3. In no event shall you use in any way whatsoever the Products and the related technical information contained in the Products or this document for any military purposes, including but not limited to, the development of mass-destruction weapons.
4. The proper names of companies or products described in this document are trademarks or registered trademarks of ROHM, its affiliated companies or third parties.

General Precaution

1. Before you use our Products, you are requested to carefully read this document and fully understand its contents. ROHM shall not be in any way responsible or liable for failure, malfunction or accident arising from the use of any ROHM's Products against warning, caution or note contained in this document.
2. All information contained in this document is current as of the issuing date and subject to change without any prior notice. Before purchasing or using ROHM's Products, please confirm the latest information with a ROHM sales representative.
3. The information contained in this document is provided on an "as is" basis and ROHM does not warrant that all information contained in this document is accurate and/or error-free. ROHM shall not be in any way responsible or liable for any damages, expenses or losses incurred by you or third parties resulting from inaccuracy or errors of or concerning such information.



BD550FHG - Web Page

Part Number	BD550FHG
Package	SSOP6
Unit Quantity	3000
Minimum Package Quantity	3000
Packing Type	Taping
Constitution Materials List	inquiry
RoHS	Yes