



CRIMP DATA (TE TERMINAL)					
TERMINAL NAME	SHIELD CRIMP SLEEVE HVP 800, 90°				
CRIMP	SIZE	TYPE		RANGE	
WIRE	COROPLAST			25 mm ²	
INSUL	(X)		(X)	12.2	
WIRE STRIP LENGHT			APPLICATOR INSTRUCTION	411-18537	
TERMINAL APPL SPEC 114-94052	PRODUCT SPECIFICATION		FEED		
TERMINALS APPLIED			SEALS		
2141157	-	-	-	-	-
-	-	-	-	-	-
-	-	-	-	-	-
-	-	-	-	-	-
-	-	-	-	-	-
-	-	-	-	-	-
WIRE SIZE (mm ² AWG)		CRIMP HEIGHT		REF SETTING	
25 mm ²		Pos.G 15.6 ±0.2			
		Pos.H 12.2 ±0.2			
-		-		-	
-		-		-	
-		-		-	
-		-		-	
-		-		-	
-		-		-	
REMARK: Applicator only used in combination with COROPLAST (LV216-2) Terminal Application Spec. 114-94052					
TYPE: Applicator for LP-Terminals					
TERMINATOR: HV CRIMPING MACHINE 528008-4					

P	LTR	REVISION RECORD	DATE	DWN	APVD	PRINTED	DWN	05DEC11	CHK	APVD	
-	E	ECR-14-001141	24JAN14	BM	GS	03FEB14	B. MUTH		G. STEGMAYER	-	
-	-	-	-	-	-	WEIGHT	DIMENSION (mm)	MATERIAL	HT TR	-	
-	-	-	-	-	-	-	-	-	-	-	
 TOLERANCES UNLESS OTHERWISE SPECIFIED SEE SHEET 1						 tyco Electronics AMP GmbH D-64625 Bensheim SPARE AND WEAR PARTS LIST					
THIS DRAWING IS A CONTROLLED DOCUMENT FOR TYCO ELECTRONICS CORPORATION. IT IS SUBJECT TO CHANGE AND THE CONTROLLING ENGINEERING ORGANIZATION SHOULD BE CONTACTED FOR THE LATEST REVISION. DIESES ZEICHNUNGSDOKUMENT WIRD DURCH TYCO ELECTRONICS CORPORATION KONTROLLIERT. ÄNDERUNGEN DIE DEM TECHNISCHEN FORTSCHRITT DIENEN, SIND VORBEHALTEN. DEN JEWEILS LETZTGÜLTIGEN ÄNDERUNGSSTAND ERFAHREN SIE AUF ANFRAGE						NAME DIE SET SHIELD CRIMP HVP800 90DEG. 25 SQMM				RESTRICTED TO -	
SCALE		SIZE	DRAWING NO		SHEET	REV					
SEE SHEET 1		A4	C-1-528041-5		1 / 3	E					

LOC	DIST	REVISIONS					
A	I	P	LYR	DESCRIPTION	DATE	DWN	APVD
		-		SEE SHEET 1	-	-	-

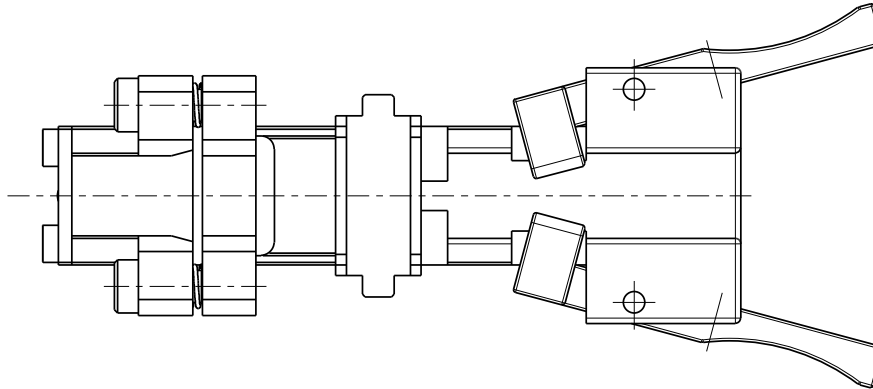
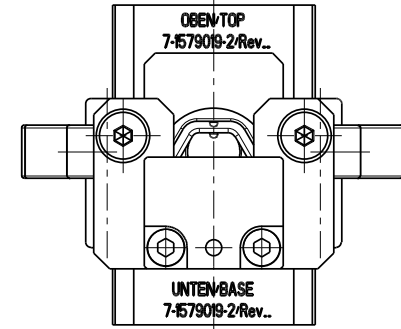
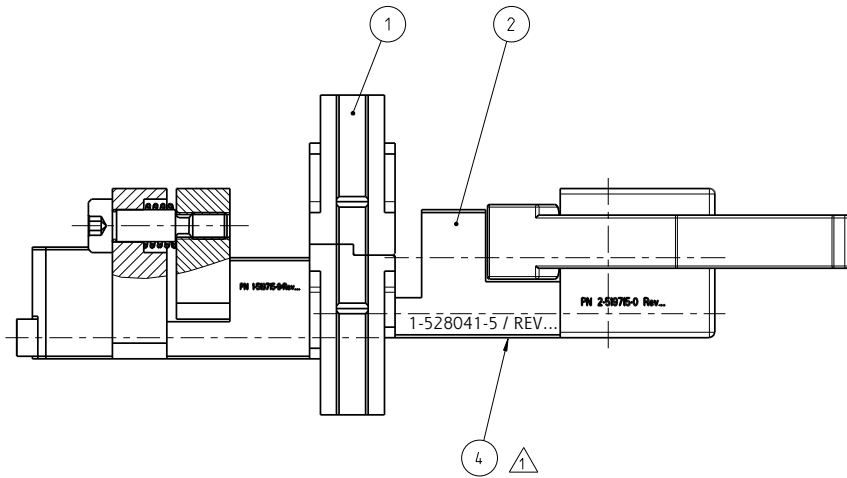
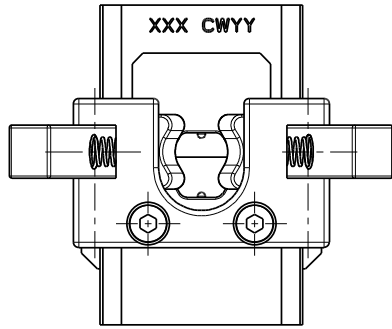

△
 Position zum Anbringen des Aufklebers.
 Position to stick on label.

Matrize in Kombination mit hydraulischer Handzange TE PN 9-1579009-1 verwendbar
 Use this die set in combination with hydraulic hand tool TE PN 9-1579009-1

GEWICHT/WEIGHT 0.8 kg

THIS DRAWING IS A CONTROLLED DOCUMENT.		DWN B. MUTH 05DEC2011	TE Connectivity	
DIMENSIONS: mm		CHK G. STEGMAYER 05DEC2011	NAME DIE SET SHIELD CRIMP HVP800 90DEG. 25 SQMM	
TOLERANCES UNLESS OTHERWISE SPECIFIED:		APVD G. STEGMAYER 05DEC2011	SIZE CAGE CODE DRAWING NO A2 00779 C-1-528041-5	
<ul style="list-style-type: none"> 0 PLC ± 1 PLC ± 2 PLC ± 3 PLC ± 4 PLC ± ANGLES ±° FINISH 		PRODUCT SPEC -	RESTRICTED TO -	
MATERIAL -		APPLICATION SPEC -	WEIGHT -	
-		CUSTOMER DRAWING		SCALE 2:1 SHEET 3 OF 3 REV E