

MAS9160

2 Outputs LDO Voltage Regulator IC

- **Dual Regulator: 2 x 150 mA**
- **Very Low Crosstalk**
- **Low Dropout: 70 mV**
- **High Ripple Rejection: 60 dB**
- **Low Noise: 30 μ Vrms**
- **Stable with Low-ESR Output Capacitors**
- **Separate Enable/Disable Control for Both Regulators**

DESCRIPTION

MAS9160 is a voltage regulator IC with two low dropout voltage regulators, which both have their own enable/disable pin allowing the regulators to be turned off or on separately by pulling the particular control to low or high.

Due to the low noise level of only 30 μ Vrms, MAS9160 is suitable for sensitive circuits, e.g., in portable applications. In addition to the low noise level, MAS9160 excels in dropout voltage (70 mV typical at 50 mA) and in very good crosstalk rejection. Also its ripple rejection ability of 60 dB at 1 kHz exceeds that of competition.

A wide range of values of Equivalent Series Resistance (ESR) of output capacitors can be used with MAS9160. This ESR range from a few m Ω up to a couple of Ohms combined with no minimum output current requirement makes the usage of MAS9160 easier and low in cost.

In order to save power the device goes into sleep mode when both regulators are disabled. An internal thermal protection circuit prevents the device from overheating. Also the maximum output current is internally limited.

FEATURES

- Low Noise
- Functionally and Pin Compatible with LP2967
- Can Be Used w/o C_{BYPASS}, see p. 7
- Internal Thermal Shutdown
- Short Circuit Protection
- MSOP-8 Package
- Several Output Voltage Options Available, see Ordering Information p. 11

APPLICATION

- Cellular Phones
- Cordless Phones
- Accessories
- Pagers
- Battery Powered Systems
- Portable Systems
- Radio Control Systems
- Low Voltage Systems

PIN CONFIGURATION AND DESCRIPTION

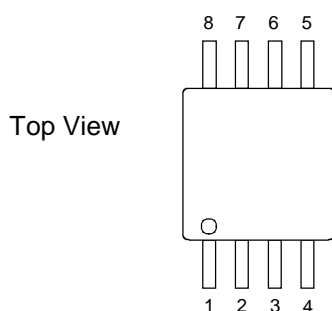

For Top Marking Information see Ordering Information p. 11

Pin Name	Pin	Type	Function
VIN	1, 8	P	Power Supply Voltage for Both Regulators
GND	4	G	Ground
CTRL1	3	I	Enable/Disable Pin for the First Regulator
CTRL2	6	I	Enable/Disable Pin for the Second Regulator
BYPASS	5	I	Pin for Bypass Capacitor
VOUT1	2	O	Output Voltage of the First Regulator
VOUT2	7	O	Output Voltage of the Second Regulator

G = Ground, I = Input, O = Output, P = Power

BLOCK DIAGRAM

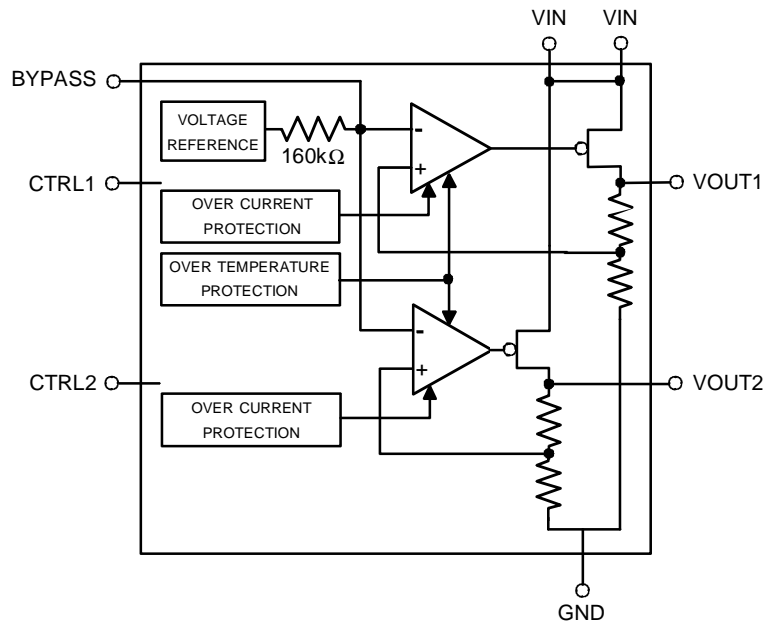

ABSOLUTE MAXIMUM RATINGS

All voltages with respect to ground.

Parameter	Symbol	Conditions	Min	Max	Unit
Supply Voltage	V_{IN}		-0.3	6	V
Voltage Range for All Pins			-0.3	$V_{IN} + 0.3$	V
ESD Rating		HBM		2	kV
Junction Temperature	T_{Jmax}			+175 (limited)	°C
Storage Temperature	T_S		-55	+150	°C

Stresses beyond those listed may cause permanent damage to the device. The device may not operate under these conditions, but it will not be destroyed.

RECOMMENDED OPERATING CONDITIONS

Parameter	Symbol	Conditions	Min	Max	Unit
Operating Junction Temperature	T_J		-40	+125	°C
Operating Ambient Temperature	T_A		-40	+85	°C
Operating Supply Voltage	V_{IN}		2.5	5.3	V

ELECTRICAL CHARACTERISTICS

$T_A = -40^\circ\text{C}$ to $+85^\circ\text{C}$, typical values at $T_A = +27^\circ\text{C}$, $V_{IN} = V_{OUT(NOM)} + 1.0\text{ V}$, $I_{OUT} = 1.0\text{ mA}$, $C_{IN} = 1.0\ \mu\text{F}$, $C_L = 1.0\ \mu\text{F}$, $C_{BYPASS} = 10\ \text{nF}$, $V_{CTRL} = 3.8\text{ V}$, unless otherwise specified

◆ Thermal Protection

Parameter	Symbol	Conditions	Min	Typ	Max	Unit
Threshold High	T_H		140	160	175	$^\circ\text{C}$
Threshold Low	T_L		130	150	165	$^\circ\text{C}$

The hysteresis of 10°C prevents the device from turning on too soon after thermal shut-down.

◆ Control Terminal Specifications

Parameter	Symbol	Conditions	Min	Typ	Max	Unit
Control Voltage OFF State ON State	V_{CTRL}		-0.3 1.6		0.55 $V_{IN} + 0.3$	V
Control Current, one control input	I_{CTRL}	$V_{CTRL} = V_{IN}$ $V_{CTRL} = 0\text{ V}$		5 0	10	μA

If CTRL-pin is not connected, the particular regulator is in OFF state (900 k Ω pull-down resistor to ground).

◆ Voltage Parameters

Parameter	Symbol	Conditions	Min	Typ	Max	Unit
Output Voltage Tolerance	V_{OUT}	$I_{OUT} = 0\text{ mA}$ $I_{OUT} = 150\text{ mA}$	$V_{OUT(NOM)} - 0.05$ $V_{OUT(NOM)} - 0.10$		$V_{OUT(NOM)} + 0.05$ $V_{OUT(NOM)} + 0.05$	V
Dropout Voltage	V_{DROP}	$I_{OUT} = 1\text{ mA}$ $I_{OUT} = 50\text{ mA}$ $I_{OUT} = 150\text{ mA}$		2 70 200		mV

◆ Current Parameters

Parameter	Symbol	Conditions	Min	Typ	Max	Unit
Continuous Output Current	I_{OUT}			150		mA
Short Circuit Current	I_{MAX}	$R_L = 0\ \Omega$		450		mA
Peak Output Current	I_{PK}	$V_{OUT} > 95\% * V_{OUT(NOM)}$		410		mA
Ground Pin Current	I_{GND}	one regulator on $I_{OUT} = 0\text{ mA}$ $I_{OUT} = 10\text{ mA}$ $I_{OUT} = 50\text{ mA}$ $I_{OUT} = 150\text{ mA}$		140 145 170 235		μA
Ground Pin Current	I_{GND}	both regulators on $I_{OUT} = 0\text{ mA}$ $I_{OUT} = 10\text{ mA}$ $I_{OUT} = 50\text{ mA}$ $I_{OUT} = 150\text{ mA}$		215 230 280 410		μA
Ground Pin Current, Sleep Mode	I_{GND}	$V_{CTRL1,2} < 0.3\text{ V}$	$T_A = 27^\circ\text{C}$ $T_A = 85^\circ\text{C}$	0.03 0.5	1.0 5.0	μA

◆ Power Dissipation

Parameter	Symbol	Conditions	Min	Typ	Max	Unit
Junction to Case Thermal Resistance	R_{JC}			39		°C/W
Junction to Ambient Thermal Resistance	R_{JA}	typical PC board mounting, still air		206		°C/W
Maximum Power Dissipation	P_d	any ambient temperature	$P_{dMAX} = \frac{T_{J(MAX)} - T_A}{R_{JA}}$ Note 1			W

Note 1: $T_{J(MAX)}$ denotes maximum operating junction temperature (+125°C), T_A ambient temperature, and R_{JA} junction-to-ambient thermal resistance (+206°C/W).

◆ Line and Load Regulation

Parameter	Symbol	Conditions	Min	Typ	Max	Unit
Line Regulation		$V_{OUT(NOM)} + 1V < V_{IN} < 5.3V$, $I_{OUT} = 60mA$		0.7		mV
Load Regulation		$I_{OUT} = 1.0$ to 50 mA $I_{OUT} = 1.0$ to 150 mA		9 24	20 45	mV

◆ Noise and Ripple Rejection

Parameter	Symbol	Conditions	Min	Typ	Max	Unit
Output Noise Voltage	V_{RMS}	300 Hz < f < 50 kHz $C_{BYPASS} = 10nF$ w/o C_{BYPASS}		30 154		μV_{rms}
Noise Density	V_N	$I_{OUT} = 50mA$, f = 1.0 kHz		150		$\frac{nV}{\sqrt{Hz}}$
PSRR		$I_{OUT} = 50mA$ f = 1 kHz f = 10 kHz f = 100 kHz		60 55 35		dB

◆ Dynamic Parameters

Parameter	Symbol	Conditions	Min	Typ	Max	Unit
Rise Time (10%...90%)		$V_{CTRL} = 0$ to 2.4 V, $I_{OUT} = 30mA$ $C_{BYPASS} = 10nF$ w/o C_{BYPASS}		4 16		ms μs
Overshoot		$V_{CTRL} = 0$ to 2.4 V, w/o C_{BYPASS}		3	5	%
Start-up Delay (from start-up to 90% * $V_{OUT(NOM)}$)		one regulator on, w/o C_{BYPASS}		26		μs

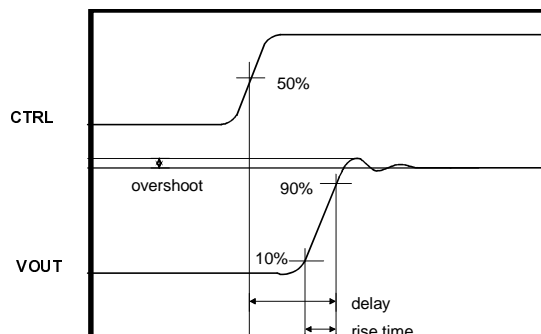

Figure1. Definitions of rise time, overshoot and start-up delay.

DETAILED DESCRIPTION

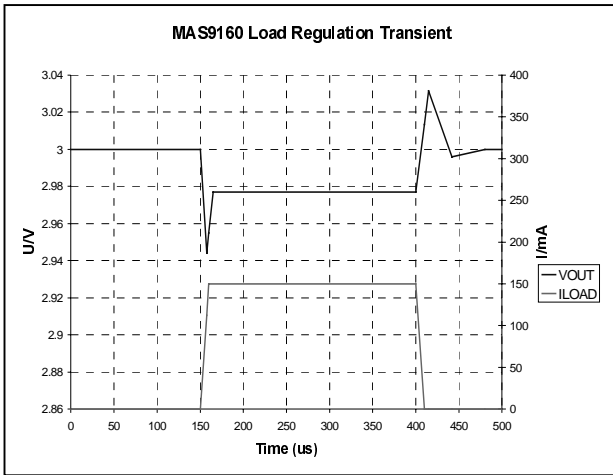

Figure 2. Typical load regulation transient. $I_{OUT} = 0 \dots 150$ mA in $10 \mu s$.

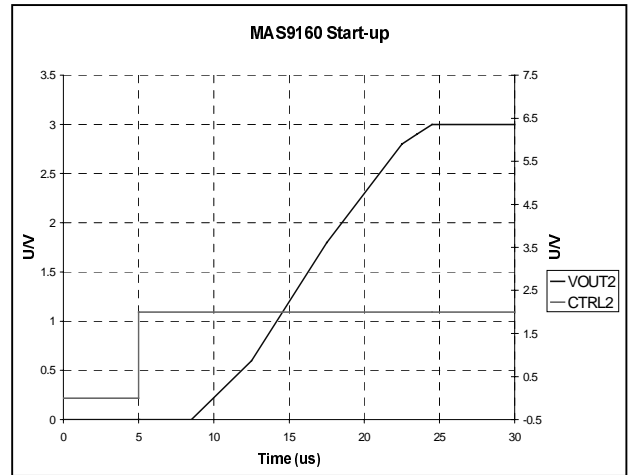

Figure 5. Start-up. $C_{BYPASS} = 10$ nF, $CTRL1 = 2$ V (i.e., regulator 1 in power on).

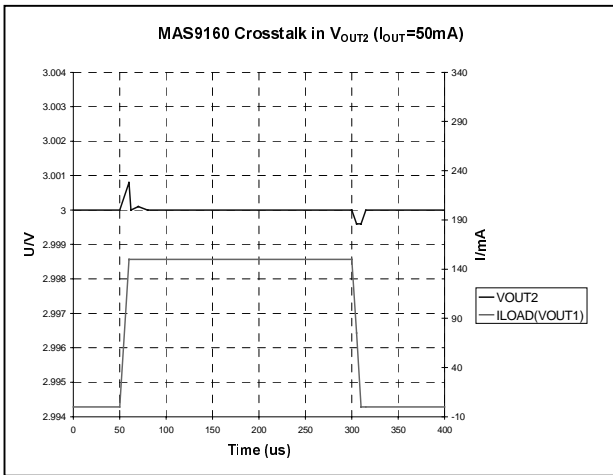

Figure 3. Typical cross-coupling at load regulation transient. V_{OUT1} : $I_{OUT} = 0 \dots 150$ mA in $10 \mu s$ (Figure 1).

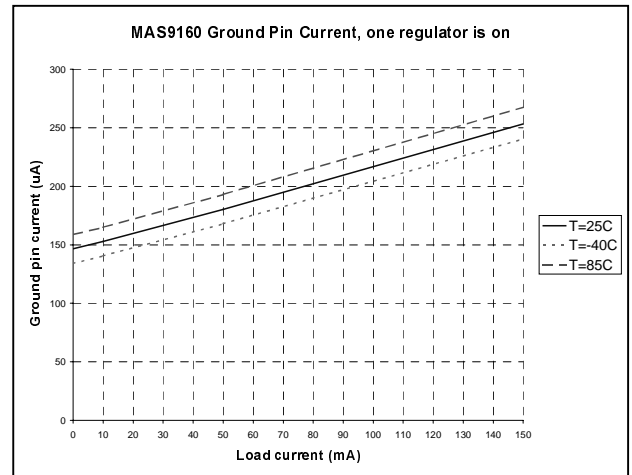

Figure 6. Current consumption vs. load current and temperature. One regulator is on.

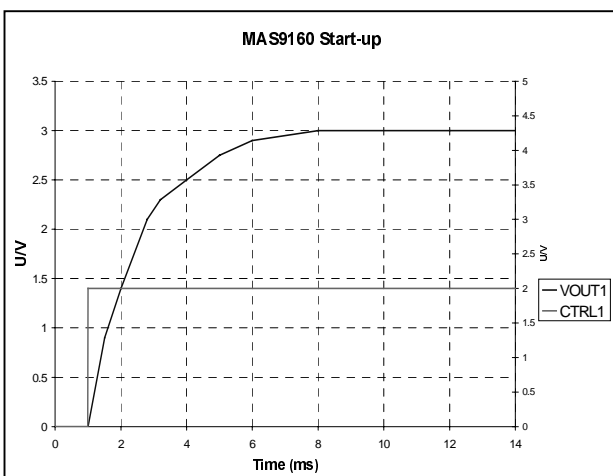

Figure 4. Start-up. $C_{BYPASS} = 10$ nF, $CTRL2 = 0$ V (i.e., regulator 2 in power off).

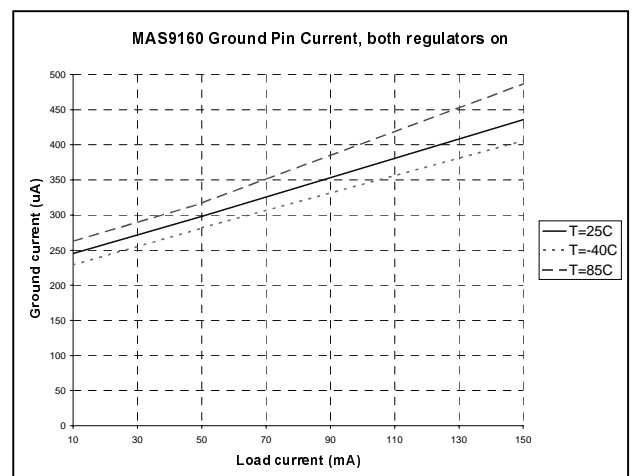

Figure 7. Current consumption vs. load current and temperature. Both regulators are on.

DETAILED DESCRIPTION

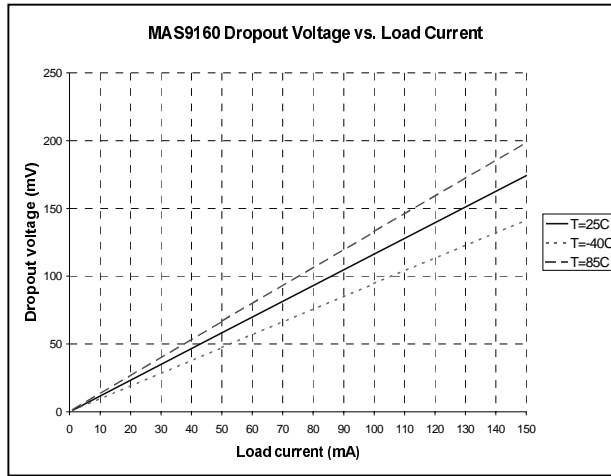

Figure 8. Dropout voltage vs. load current and temperature.

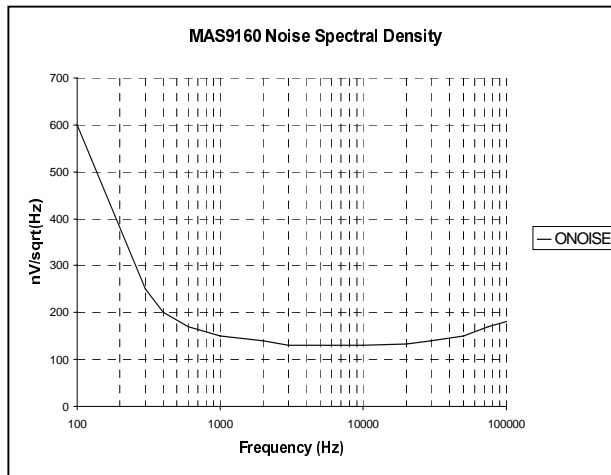

Figure 9. Output noise spectral density. $C_{\text{BYPASS}} = 10 \text{ nF}$, $C_L = 1 \mu\text{F}$, $I_{\text{OUT}} = 50 \text{ mA}$.

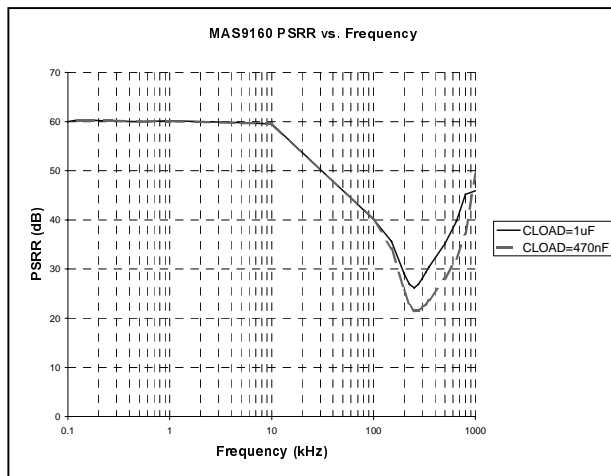
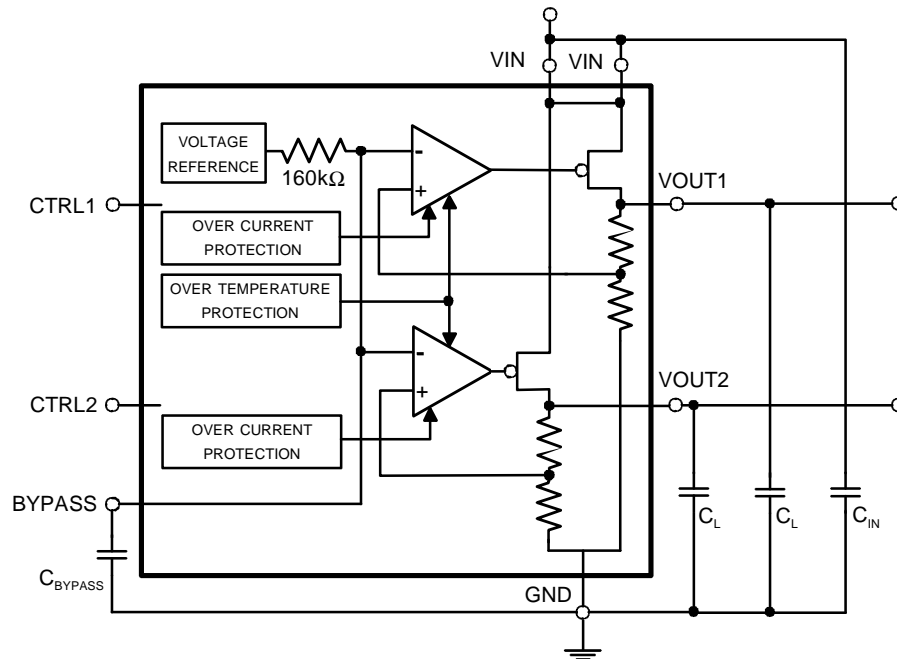
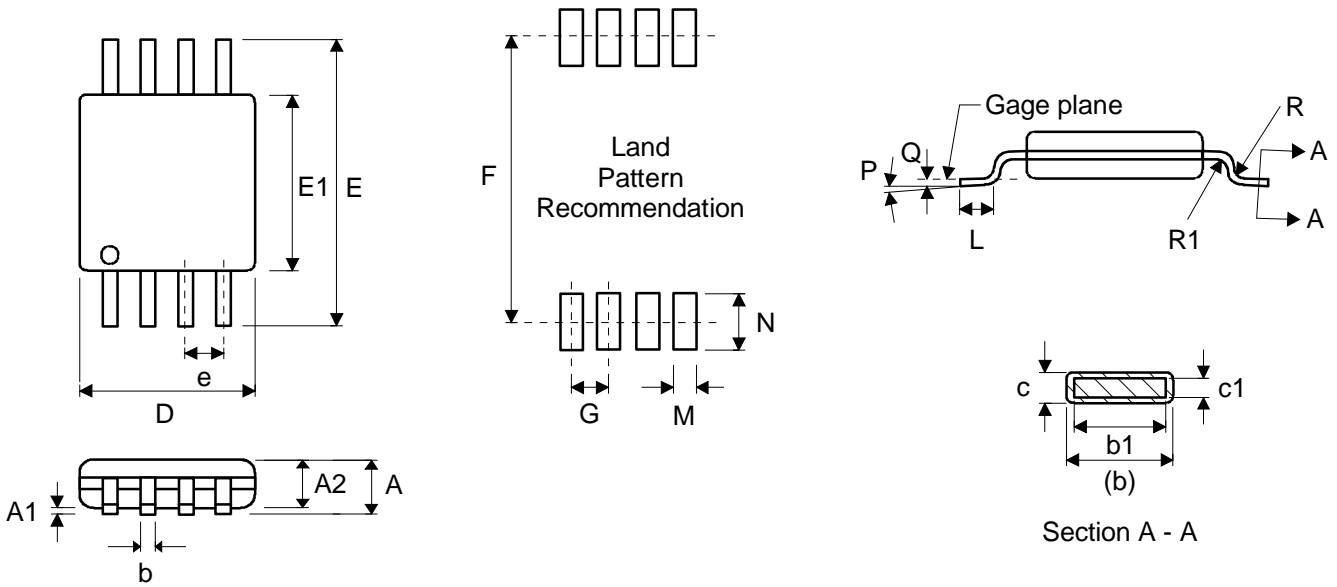

Figure 10. PSRR vs. frequency. $C_{\text{BYPASS}} = 10 \text{ nF}$, $I_{\text{OUT}} = 50 \text{ mA}$.

APPLICATION INFORMATION

Parameter	Symbol	Min	Max	Unit	Note
Output Capacitance	C_L	0.22		μF	<ol style="list-style-type: none"> 1. Ceramic and film capacitors can be used. 2. The value of C_L should be smaller than or equal to the value of C_{IN}.
Effective Series Resistance	ESR	0.01	3	Ohm	<ol style="list-style-type: none"> 1. When within this range, stable with all $I_{OUT} = 0 \text{ mA} \dots 150 \text{ mA}$ values.
Bypass Capacitance (Optional: if C_{BYPASS} is not used, noise performance and PSRR decline, but rise time is improved. If one of the regulators is already on, C_{BYPASS} does not have effect on rise time.)	C_{BYPASS}	Typically 0.01		μF	<ol style="list-style-type: none"> 1. Ceramic and film capacitors are best suited. For maximum output voltage accuracy DC leakage current through capacitor should be kept as low as possible. In any case DC leakage current must be below 100 nA.
Input Capacitance	C_{IN}	0.5		μF	<ol style="list-style-type: none"> 1. A big enough input capacitance is needed to prevent possible impedance interactions between the supply and MAS9160. 2. Ceramic, tantalum, and film capacitors can be used. If a tantalum capacitor is used, it should be checked that the surge current rating is sufficient for the application. 3. In the case that the inductance between a battery and MAS9160 is very small ($< 0.1 \mu\text{H}$) $0.47 \mu\text{F}$ input capacitor is sufficient. 4. The value of C_{IN} should not be smaller than the value of C_L.

Values given on the table are minimum requirements unless otherwise specified. When selecting capacitors, tolerance and temperature coefficient must be considered to **make sure that the requirement is met in all potential operating conditions.**

PACKAGE (MSOP-8) OUTLINE

Symbol	Min	Nom	Max	Unit
A			1.10	mm
A1	0		0.15	mm
A2	0.75	0.85	0.95	mm
b	0.22		0.38	mm
b1	0.22	0.30	0.33	mm
c	0.08		0.23	mm
c1	0.08		0.18	mm
D		3.00 BSC		mm
E		4.90 BSC		mm
E1		3.00 BSC		mm
e		0.65 BSC		mm
F		4.8		mm
G		0.65		mm
L	0.40	0.60	0.80	mm
(Terminal length for soldering)				
M		0.41		mm
N		1.02		mm
P	0°		8°	
Q		0.25 BSC		mm
R	0.07			mm
R1	0.07			mm

Dimensions do not include mold or interlead flash, protrusions or gate burrs.
 All measurement according to JEDEC standard MO-187.

SOLDERING INFORMATION

Resistance to Soldering Heat	According to RSH test IEC 68-2-58/20 2*220°C
Maximum Reflow Temperature	235°C
Maximum Number of Reflow Cycles	2
Seating Plane Co-planarity	max 0.08 mm
Lead Finish	Solder plate 7.62 - 25.4 µm, material Sn 85% Pb 15%

EMBOSSED TAPE SPECIFICATIONS

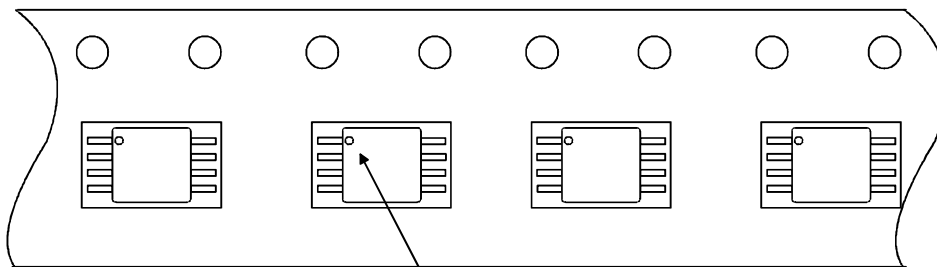
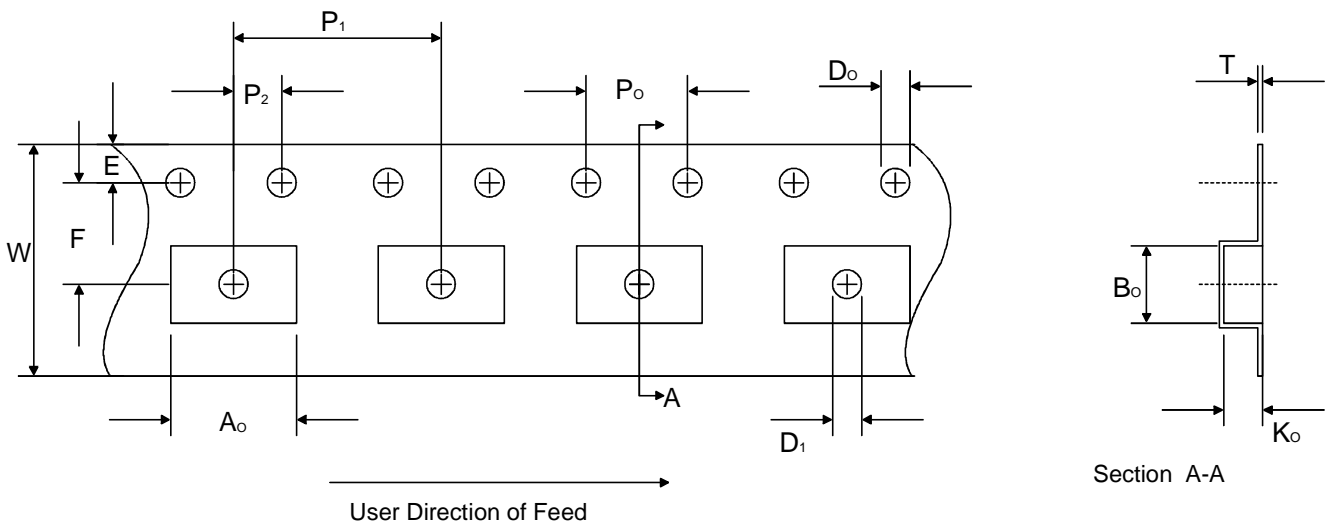

Pin 1 Designator

Dimension	Min/Max	Unit
A_0	5.00 ±0.10	mm
B_0	3.20 ±0.10	mm
D_0	1.50 +0.1/-0.0	mm
D_1	1.50 min	mm
E	1.75	mm
F	5.50 ±0.05	mm
K_0	1.45 ±0.10	mm
P_0	4.0	mm
P_1	8.0 ±0.10	mm
P_2	2.0 ±0.05	mm
T	0.3 ±0.05	mm
W	12.00 +0.30/-0.10	mm

REEL SPECIFICATIONS

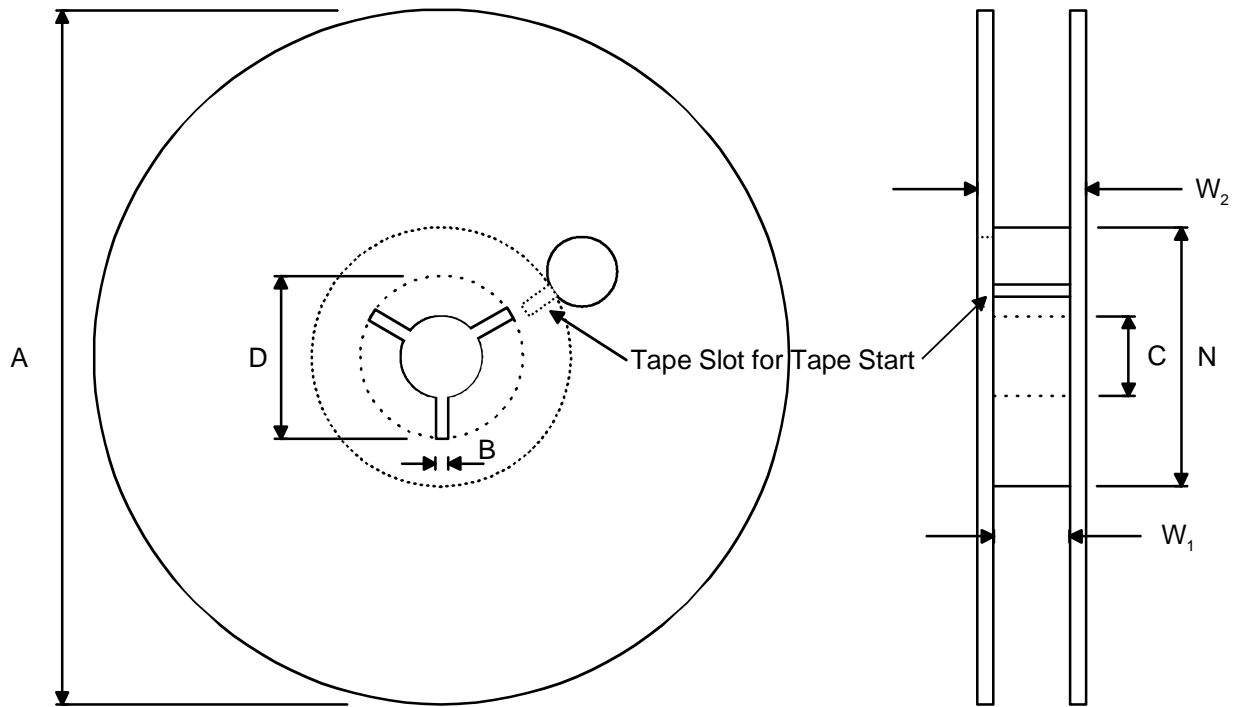

5000 Components on Each Reel

Reel Material: Conductive, Plastic Antistatic or Static Dissipative

Carrier Tape Material: Conductive

Cover Tape Material: Static Dissipative

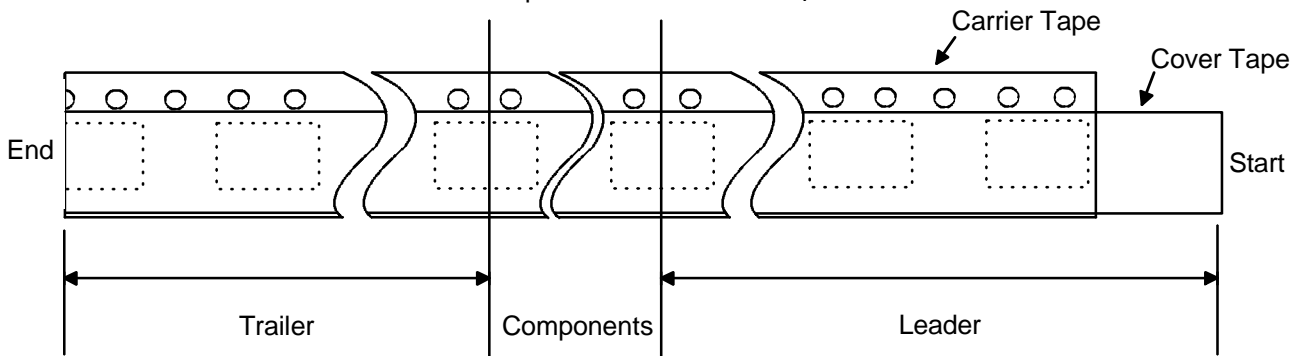

Dimension	Min	Max	Unit
A		330	mm
B	1.5		mm
C	12.80	13.50	mm
D	20.2		mm
N	50		mm
W ₁ (measured at hub)	12.4	14.4	mm
W ₂ (measured at hub)		18.4	mm
Trailer	160		mm
Leader	390, of which minimum 160 mm of empty carrier tape sealed with cover tape		mm
Weight		1500	g

ORDERING INFORMATION

Product Code	Product	V _{OUT1(NOM)}	V _{OUT2(NOM)}	Top Marking	Package	Comments
MAS9160ASM4-T	Voltage Regulator IC	1.8 V	1.8 V	60A4	MSOP-8	Tape and Reel
MAS9160ASMH-T	Voltage Regulator IC	1.8 V	2.8 V	60AH	MSOP-8	Tape and Reel
MAS9160ASM3-T	Voltage Regulator IC	2.5 V	2.5 V	60A3	MSOP-8	Tape and Reel
MAS9160ASMJ-T	Voltage Regulator IC	2.5 V	2.8 V	60AJ	MSOP-8	Tape and Reel
MAS9160ASM2-T	Voltage Regulator IC	2.8 V	2.8 V	60A2	MSOP-8	Tape and Reel
MAS9160ASM6-T	Voltage Regulator IC	3.0 V	3.0 V	60A6	MSOP-8	Tape and Reel
MAS9160ASM1-T	Voltage Regulator IC	3.3 V	3.3 V	60A1	MSOP-8	Tape and Reel

For more voltage options contact Micro Analog Systems Oy.

LOCAL DISTRIBUTOR

MICRO ANALOG SYSTEMS OY CONTACTS

Micro Analog Systems Oy Kamreerintie 2, P.O.Box 51 FIN-02771 Espoo, FINLAND http://www.mas-oy.com	Tel. (09) 80 521 Tel. Int. +358 9 80 521 Telefax +358 9 805 3213 E-mail: info@mas-oy.com
--	--

NOTICE

Micro Analog Systems Oy reserves the right to make changes to the products contained in this data sheet in order to improve the design or performance and to supply the best possible products. Micro Analog Systems Oy assumes no responsibility for the use of any circuits shown in this data sheet, conveys no license under any patent or other rights unless otherwise specified in this data sheet, and makes no claim that the circuits are free from patent infringement. Applications for any devices shown in this data sheet are for illustration only and Micro Analog Systems Oy makes no claim or warranty that such applications will be suitable for the use specified without further testing or modification.