

120 Amp Schottky OR'ing Rectifier HS12510–HS12515

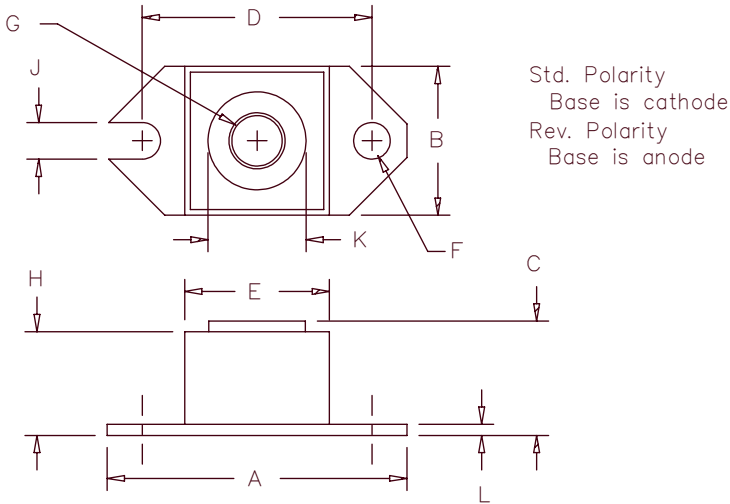

Dim.	Inches		Millimeter		Notes
	Minimum	Maximum	Minimum	Maximum	
A	1.52	1.56	38.61	39.62	
B	.725	.775	18.42	19.69	
C	.605	.625	15.37	15.88	
D	1.182	1.192	30.02	30.28	
E	.745	.755	18.92	19.18	Sq.
F	.152	.160	3.86	4.06	Dia.
G			1/4–20 UNC–2B		
H	.525	.580	13.34	14.73	
J	.156	.160	3.96	4.06	
K	.495	.505	12.57	12.83	Dia.
L	.120	.130	3.05	3.30	

HALF-PAK

Microsemi Catalog Number	Industry Part Number	Working Peak Reverse Voltage	Repetitive Peak Reverse Voltage
HS12510*		10V	10V
HS12515*	125NQ015	15V	15V

* Add suffix R for Reverse Polarity

- Schottky Barrier Rectifier
- Guard Ring Protection
- Low Forward Voltage
- 125°C Junction Temperature
- V_{RRM} 10–15 Volts
- Reverse Energy Tested
- ROHS Compliant

Electrical Characteristics

Average forward current	$I_F(AV)$ 120 Amps	$T_C = 93^\circ\text{C}$, square wave, $R_{\theta JC} = 0.4^\circ\text{C/W}$
Maximum surge current	I_{FSM} 2000 Amps	8.3ms, half sine, $T_J = 125^\circ\text{C}$
Maximum repetitive reverse current	$I_R(OV)$ 2 Amps	$f = 1\text{ KHZ}$, $1\mu\text{s}$ square wave, $T_J = 25^\circ\text{C}$
Max peak forward voltage	V_{FM} 0.45 Volts	$I_{FM} = 120\text{A}$: $T_J = 25^\circ\text{C}^*$
Max peak reverse current	I_{RM} 1 Amp	V_{RRM} , $T_J = 125^\circ\text{C}^*$
Max peak reverse current	I_{RM} 8mA	V_{RRM} , $T_J = 25^\circ\text{C}$
Typical junction capacitance	C_J 9500pF	$V_R = 5.0\text{V}$, $T_C = 25^\circ\text{C}$, $f = 1\text{MHz}$

*Pulse test: Pulse width 300 μsec , Duty cycle 2%

Thermal and Mechanical Characteristics

Storage temp range	T_{STG}	-55°C to 175°C
Operating junction temp range	T_J	-55°C to 125°C
Max thermal resistance	$R_{\theta JC}$	0.4°C/W junction to case
Typical thermal resistance (greased)	$R_{\theta CS}$	0.12°C/W case to sink
Mounting Base Torque		15–25 inch pounds
Terminal Torque		20–40 inch pounds
Weight		1.1 ounces (32 grams) typical

HS12510-HS12515

Figure 1
Typical Forward Characteristics

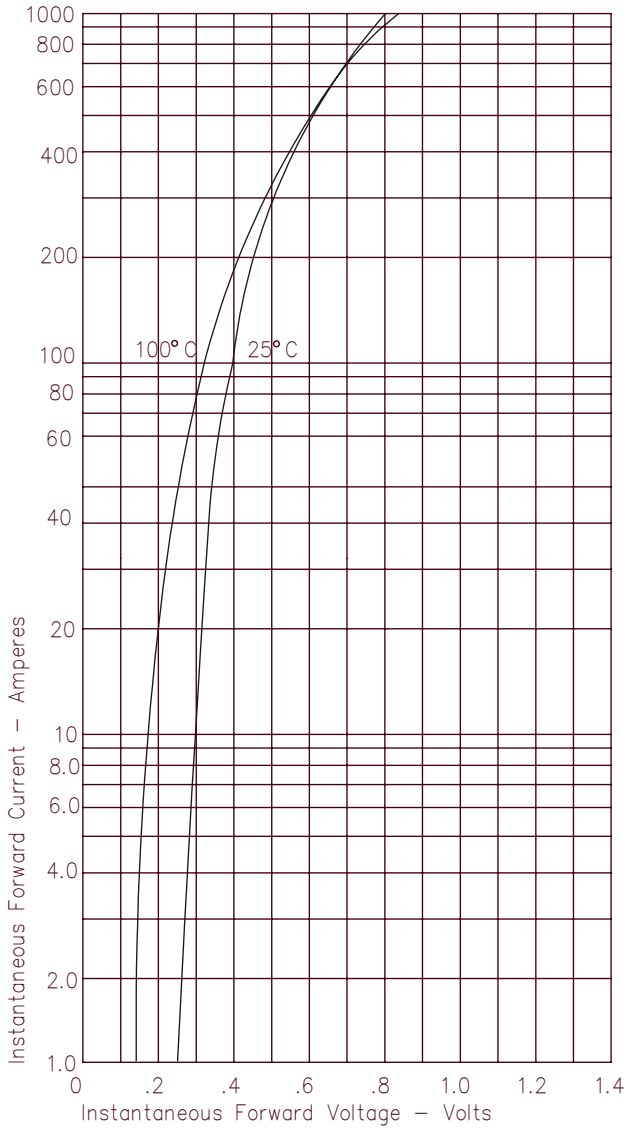

Figure 3
Typical Junction Capacitance

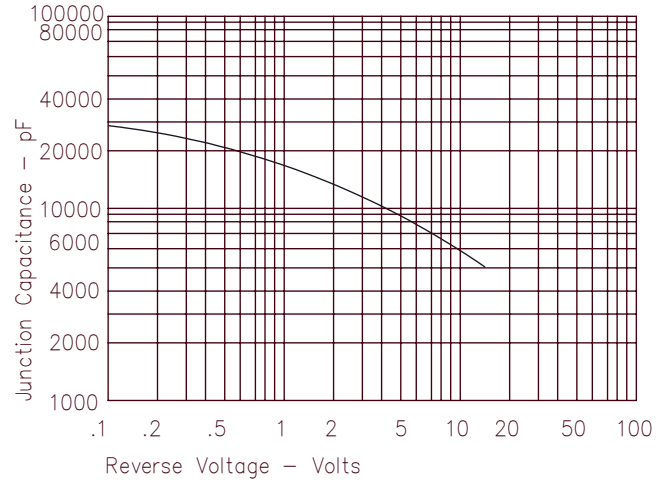

Figure 4
Forward Current Derating

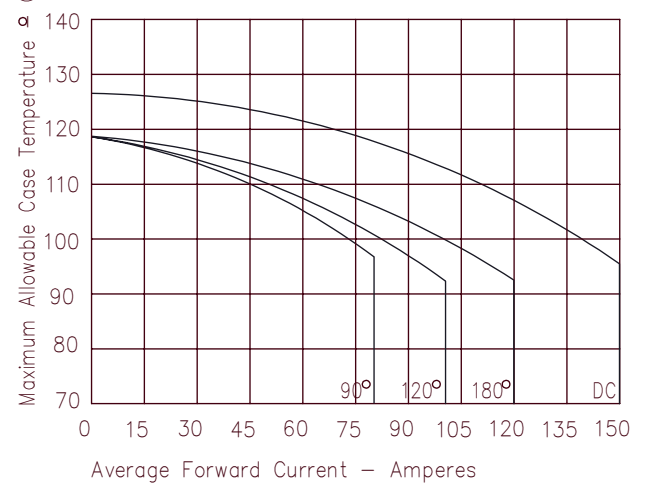

Figure 2
Typical Reverse Characteristics

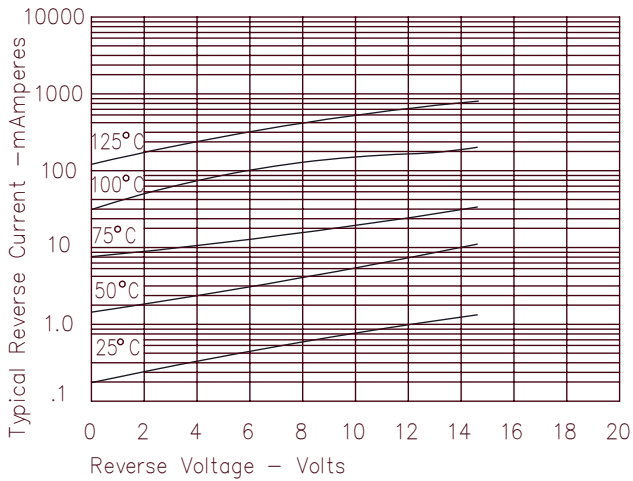

Figure 5
Maximum Forward Power Dissipation

