

ATLANTIC VERSION TERMINATOR INTERFACE ADAPTER	PART NUMBER	REVISION	DESCRIPTION	FEED TYPE	APPLICATOR STYLE CONVERSION CHART						
					CONVERT TO	PART NUMBERS REQUIRED					
	2150320-2	A	FINE CRIMP HEIGHT ADJUST	PNEUMATIC	-	-	-	-	-	-	
	2150320-5	A	FINE CRIMP HEIGHT ADJUST	SERVO LATCH PLATE <sup>4</sup>	SERVO LATCH PLATE	2119951-1	1901697-1	8-2150320-5	-	-	2168400-7 (QUANTITY 2)
					SMART APPLICATOR	2161326-1	-	8-2150320-4	-	-	-
	2150320-6	A	NON-CRIMP HEIGHT ADJUST	SERVO LATCH PLATE <sup>4</sup>	PNEUMATIC FEED	2119950-1	2119792-2	-	2119641-1	-	2063440-2
					-	-	-	-	-	-	-
	2150320-7	A	FINE CRIMP HEIGHT ADJUST	NONE	-	-	-	-	-	-	-
	7-2150320-7	A	CRIMP TOOLING KIT	-	-	-	-	-	-	-	-

APPLICATOR DATA		
CRIMP	SIZE	TYPE
WIRE	4.06 mm [.160]	F
INSUL	5.60 mm [.220]	F
APPL INSTRUCTIONS 408-10390		

TERMINAL DATA: TE TERMINAL		TE CRIMP SPECIFICATION
TERMINAL NAME: FASTIN-FASTION REC. SERIES 9.5		
WIRE STRIP LENGTH 6.60-7.20 mm [.260-.283 IN]		INSULATION DIAMETER RANGE Ø4.00-5.10 mm [.157-.201 IN]
TERMINAL APPLICATION SPECIFICATION 114-18022 <sup>10</sup>		-
TERMINALS APPLIED		
TE TERMINAL	TE TERMINAL	TE TERMINAL
962833-1		

WIRE SIZE	CRIMP HEIGHT mm [INCH]	CRIMP HEIGHT REFERENCE SETTING <sup>9</sup>
6.00mm2	2.86 +/- 0.05 [.113 +/- .002]	8.0
5.00mm2	2.68 +/- 0.05 [.106 +/- .002]	9.8
4.00mm2	2.50 +/- 0.05 [.098 +/- .002]	12.0

- <sup>1</sup> RECOMMENDED SPARE PARTS
- <sup>2</sup> GREASE BEARING SURFACES LIGHTLY
- 3. LUBRICATE DAILY PER THE APPLICATOR INSTRUCTION SHEET SUPPLIED WITH THE APPLICATOR.
- <sup>4</sup> APPLICATOR SPECIFIC DATA TO BE ENTERED INTO BLANK MEMORY CHIP AT ASSEMBLY. SEE BELOW FOR PART NUMBER:  
 PNEUMATIC FEED WITH "SMART APPLICATOR" CONVERSION: 8-2150320-4  
 SERVO FEED WITH "FINE CRIMP HEIGHT ADJUST": 8-2150320-5  
 SERVO FEED WITH "NON-CRIMP HEIGHT ADJUST": 8-2150320-6
- 5. ADJUSTMENT OF THE STRIPPER MAY BE REQUIRED WHEN MOVING THE APPLICATOR BETWEEN BENCH AND LEADMAKER APPLICATIONS.
- <sup>6</sup> APPLY PART NUMBER 1-23419-5 LOCTITE TO THREADS OF ITEMS 50, 62 & 242. FOR -6 ONLY APPLY PART NUMBER 1-23419-5 LOCTITE TO THREADS OF ITEMS 37, 50 & 242.
- <sup>7</sup> GREASE THREADS, GROOVE AND O-RING ON ITEMS 35 & 252.
- <sup>8</sup> MAGNET, ITEM 166 MUST BE ORIENTED CORRECTLY IN ORDER TO PROPERLY ACTUATE THE COUNTER.
- <sup>9</sup> CRIMP HEIGHT REFERENCE SETTING WAS THE SETTING USED WHEN THE APPLICATOR WAS QUALIFIED AT THE FACTORY. ADJUSTMENT MAY BE NECESSARY WHEN RUNNING APPLICATOR IN THE FIELD.
- <sup>10</sup> TERMINAL PITCH NOT COMPATIBLE WITH MECHANICAL FEED.
- <sup>11</sup> WHEN ASSEMBLING -6 NON-CRIMP HEIGHT ADJUST APPLICATOR USE SHIM PACK 2119957-2 TO ALIGN APPLICATOR'S MAXIMUM WIRE CRIMP HEIGHT AT NORMAL TERMINATOR SHUT HEIGHT
- <sup>12</sup> PRODUCT SPECIFICATION (RE: TENSILE VALUES ETC) IS 108-18149-1

**\*WARNING**  
 ON INSTALLATION, SET WIRE DISC, ITEM 40 TO LARGEST WIRE SIZE SETTING. USE OF SETTINGS BELOW MINIMUM REQUIRED CRIMP HEIGHT SETTING WILL CAUSE DAMAGE TO CRIMP TOOLING.

-	-	1	-	-	2119957-2	APPLICATOR SHIM PACK	260
-	1	-	1	1	8-21084-0	O-RING, .676 ID, .070 DIA. MAT.	252
-	-	-	-	1	2119640-1	PUSH ROD, AIR FEED	250
-	-	-	-	1	2079988-1	BUSHING, LCH5-12, MISUMI	249
-	-	-	-	1	2119641-1	FEED CAM, AIR FEED	248
-	1	-	1	1	2119798-1	DETENT PIN	247
-	1	-	1	1	1-22279-3	SPRING, COMPRESSION	246
-	-	1	-	-	2119759-1	RAM, AMP STYLE, END FEED, NON-ADJUST	245
-77	-7	-6	-5	-2	PART NO	DESCRIPTION	ITEM NO

**ATLANTIC VERSION**  
 Shown on sheets 1 of 4 & 2 of 4  
 (Pacific version shown on sheets 3 of 4 & 4 of 4)

SET UP GAUGE	LOC	DIST	REVISIONS			
2119599-2	A	66	REV	DATE	BY	APPD
	A		RELEASED	01MAY2013	RK	TE

-	1	1	1	1	2119082-9	CAM, SNAIL, INSULATION ADJUSTMENT	244
-	1	1	1	1	2079764-1	WASHER, WAVE SPRING, CREST-TO-CREST	243
-	1	1	1	1	2119083-1	RETAINER, INSULATION DIAL	242
-	-	2	2	-	2168400-7	SHCS, LOW HEAD, RoHS, M5 X 10	240
-	-	-	-	-	2119580-1	MECHANICAL FEED ASSEMBLY	239
-	-	-	-	1	2063440-2	AIR FEED MODULE	238
-	-	1	1	-	2119740-2	TAG, IDENTIFICATION	213
-	-	REF	REF	-	1901697-1	FEED FINGER ASSEMBLY, EF	183
-	1	1	1	1	6-993111-6	PIN, SLOTTED SPRING 3.0 X 14.0	177
-	1	1	1	1	8-22280-7	SPRING, COMPRESSION	176
-	1	1	1	1	1752353-2	GUIDE PIN, HOLDDOWN	175
-	1	1	1	1	1901680-2	GUIDE PIN, HOLDDOWN	174
-	-	-	-	2	21045-3	RING, RETAIN, EXTERN, 3/16 CRESCENT	172
-	1	1	1	1	994969-1	MAGNET, RARE EARTH HIGH ENERGY	166
-	REF	REF	REF	REF	994970-2	COUNTER, MAGNETIC	164
-	-	-	-	1	240638-1	SPRING, FEED FINGER	163
-	-	-	-	1	3-23627-7	PIN, RETAIN, GRVD, 3/16 X .854	137
-	-	REF	REF	-	SEE NOTE 4	MEMORY CHIP, PROGRAMMED	135
-	-	1	1	-	1633743-1	SERVO FEED LATCH ASM	133
-	1	1	1	1	455888-4	SPACER, CRIMPER	82
-	1	1	1	1	2119791-9	DEPRESSOR, WIRE	73
-	1	1	1	1	2119956-2	DOCUMENTATION PACKAGE	71
-	2	2	2	2	2-18032-2	SCR, SET, FLT POINT M3 X 10.0	70
-	1	1	1	1	2119943-1	WASHER, SPACER	69
-	1	-	-	1	2119740-1	TAG, IDENTIFICATION	67
-	2	2	2	2	2168078-1	SCREW, DRIVE, RH, RoHS, 2 x .188	66
-	1	1	1	1	1901681-1	HOLDDOWN, TERMINAL	65
-	2	2	2	2	2168400-5	SHCS, LOW HEAD, RoHS, M4 X 20	64
-	1	-	1	1	2119793-1	LIMITER, ADJUSTMENT BOLT	63
-	3	-	3	3	992763-5	SCR, SET, SOC, CONE POINT, M3 X 4.0	62
-	1	1	1	1	2079383-4	SCR, BHSC, RoHS (M4 X 8)	60
-	-	-	-	-	2063961-1	FEED FINGER	58
-	3	3	3	3	2168400-1	SHCS, LOW HEAD, RoHS, M4 X 12	57
-	2	2	2	2	2168083-8	SCR, SKT HD CAP, RoHS, M4 X 16	56
-	2	2	2	2	5018030-2	NUT, HEX, REG, RoHS, M4	55
-	2	2	2	2	5018030-1	NUT, HEX, REG, RoHS, M3	54
-	2	2	2	2	986965-8	NUT, LOCK, HEX, TORQUE (M4)	53
-	1	1	1	1	1-5018030-0	NUT, HEX, REG, RoHS, M3.5	52
-	-	-	-	1	2119792-2	PAWL, EF, AIR	51
-	1	1	1	1	1-1752354-5	STANDOFF, HOLD-DOWN	50
-	-	-	-	1	18023-9	SCR, SKT HD CAP M4 X 6.0	49
-	1	1	1	1	2119655-5	APPLICATOR BASIC ASSEMBLY, EF	46
-	1	-	1	1	2119369-1	RAM, AMP STYLE, END FEED	44
-	1	1	1	1	2079383-7	SCR, BHSC, RoHS (M8 X 25)	41
-	1	-	1	1	2119645-1	DISC, NUMBERED FA WIRE ADJUSTMENT	40
-	1	-	1	1	2119957-1	APPLICATOR SHIM PACK	39
-	1	1	1	1	2119644-2	RAM WASHER, PRECISION	38
-	1	1	1	1	2119085-1	FA HEAD, ATLANTIC STYLE	37
-	1	-	1	1	2119092-1	BOLT, ADJUSTMENT	35
-	7	7	7	7	1-18028-2	WASHER, FLAT, REG M4	33
-	2	2	2	2	2168083-9	SCR, SKT HD CAP, RoHS, M4 X 20	31
-	2	2	2	2	1-2168083-0	SCR, SKT HD CAP, RoHS, M4 X 10	29
-	1	1	1	1	690455-3	STRIPPER, FRONT CASTING	27
-	2	2	2	2	1320906-1	STUD, THREADED	25
-	1	1	1	1	1-1752371-5	PLATE, STRIP GUIDE	24
-	1	1	1	1	240825-1	PLATE, STRIP HOLD DOWN	23
-	2	2	2	2	2-22281-3	SPRING, COMPRESSION	22
-	1	1	1	1	1752373-4	DRAG	20
-	2	2	2	2	1901259-8	GUIDE, LOWER STRIP	18
-	4	4	4	4	1-2079383-1	SCR, BHSC, RoHS (M6 X 12)	17
-	1	1	1	1	2-240641-4	SPACER	16
-	1	1	1	1	1752360-1	SPACER, HOLD-DOWN	13
-	1	1	1	1	240833-3	PLATE, REAR SHEAR	11
-	-	-	-	-	-	-	10
-	1	1	1	1	690482-5	PLATE, FRONT SHEAR	9
-	1	1	1	1	1333223-9	ANVIL, COMBINATION	8
-	1	1	1	1	2217206-7	BLADE, SLUG	7
-	-	-	-	-	-	-	6
-	1	1	1	1	2-240641-7	SPACER	5
-	1	1	1	1	2-238009-9	BLOCK, FL CRIMPER SPACER	4
-	1	1	1	1	7-2119582-4	CRIMPER, INSULATION F PREMIUM	3
-	1	1	1	1	455888-5	SPACER, CRIMPER	2
-	1	1	1	1	1-456414-2	CRIMPER, WIRE	1
-77	-7	-6	-5	-2	PART NO	DESCRIPTION	ITEM NO

DIMENSIONS:		TOLERANCES UNLESS OTHERWISE SPECIFIED:		DWG		CHK		APPD		NAME	
mm	0 PLC ±.5	1 PLC ±.3	2 PLC ±.13	3 PLC ±.013	4 PLC ±.0001	ANGLES ±.0001	FINISH	Y. YIN	26MAR2013	G. BAILEY	26MAR2013
MATERIAL		FINISH		WEIGHT		SIZE		CAGE CODE		DRAWING NO	
						A1		00779		C=2150320	
Customer Accessible Production Drawing				SCALE		SHEET		1 OF 4		REV	
										A	

LOC		DIST		REVISIONS			
A	66	P	LTM	DESCRIPTION	DATE	DWN	APVD
		-	-	SEE SHEET 1	-	-	-

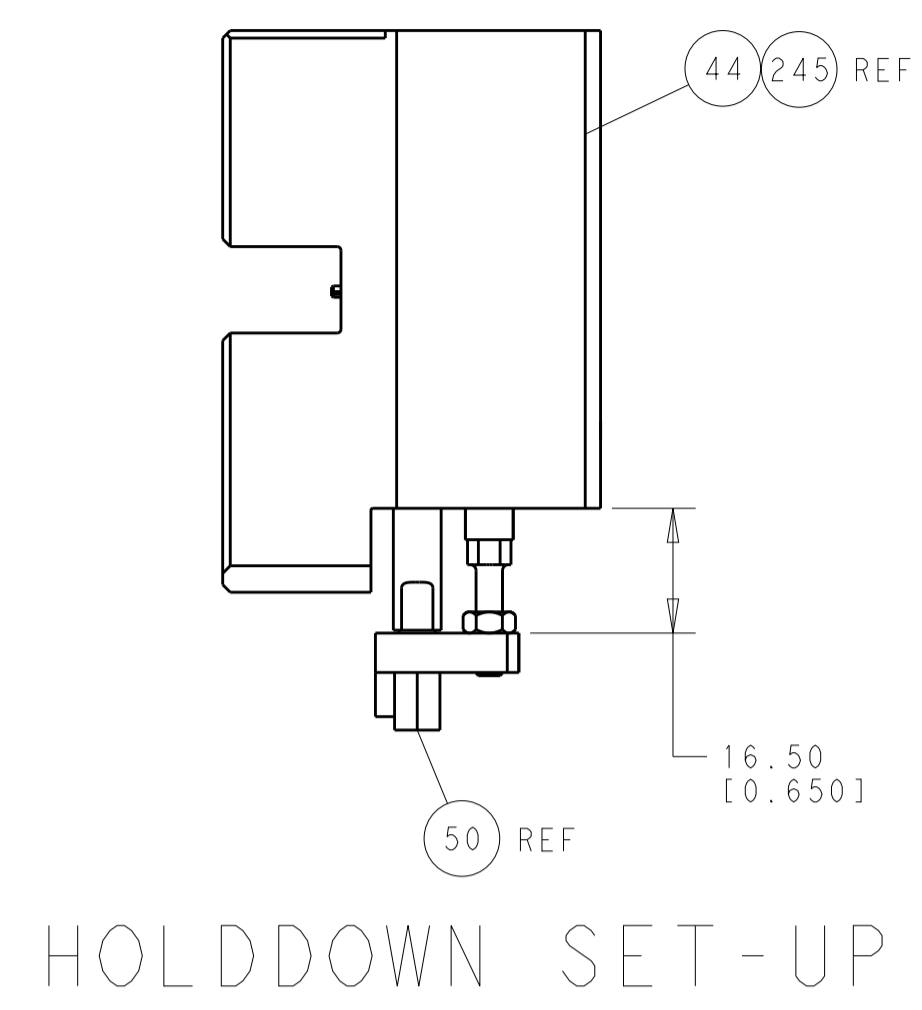

FEED TYPE

PNEUMATIC

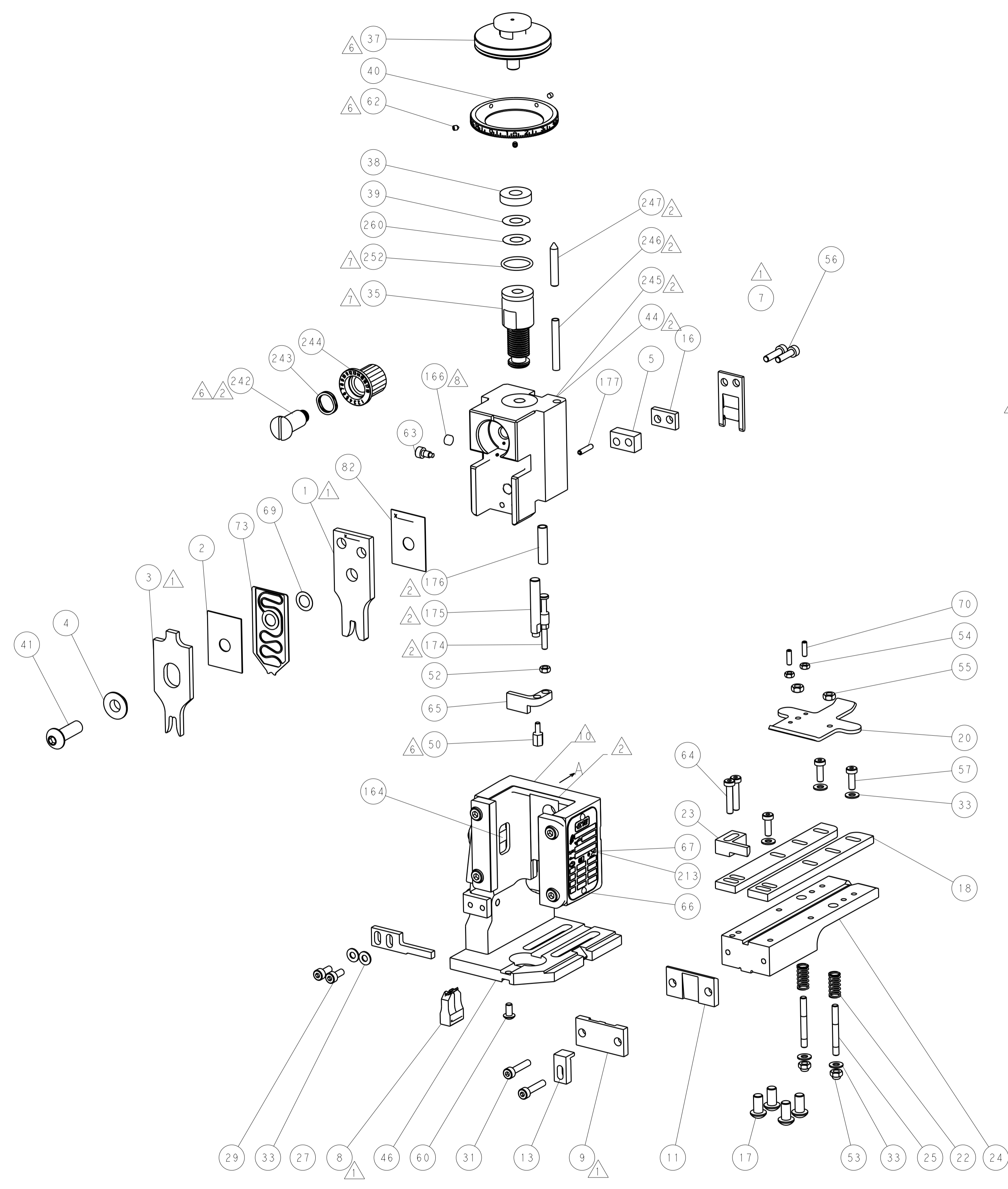
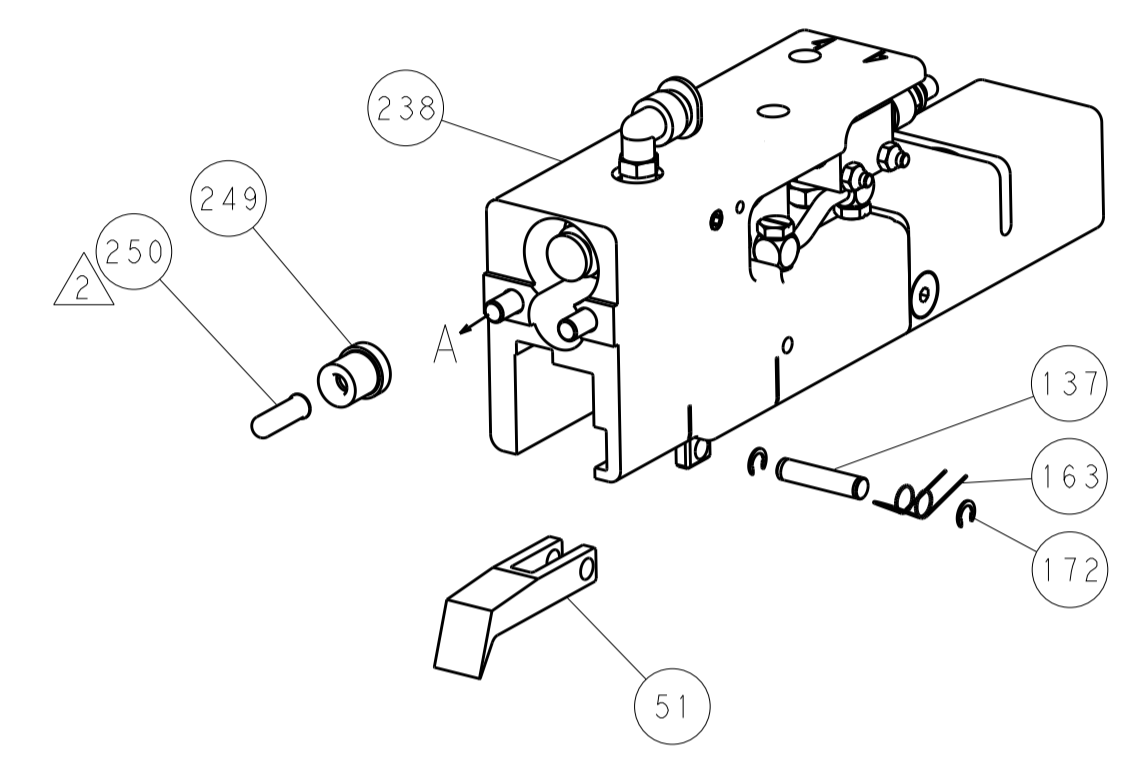

SERVO LATCH PLATE

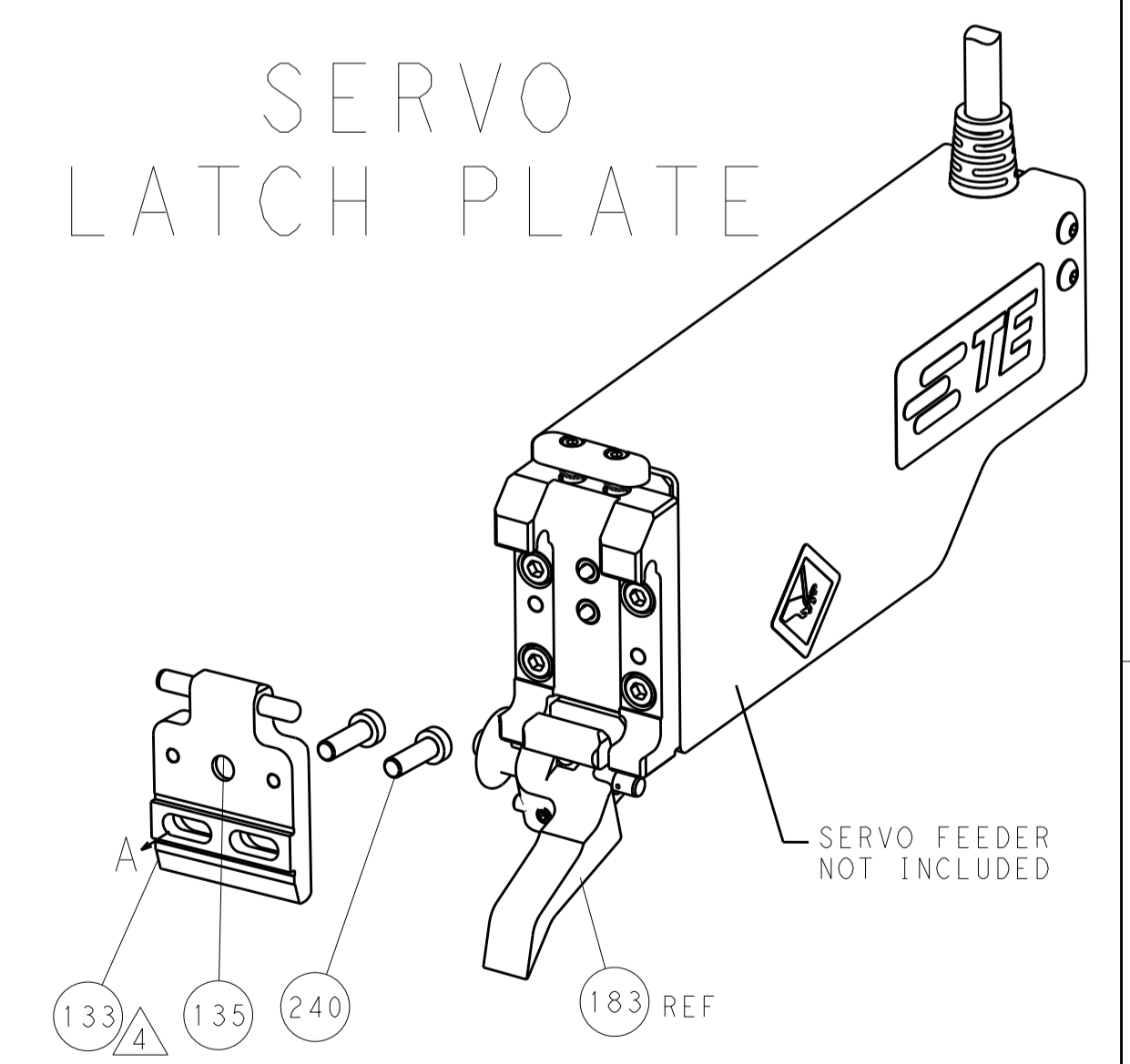

CAM POSITION

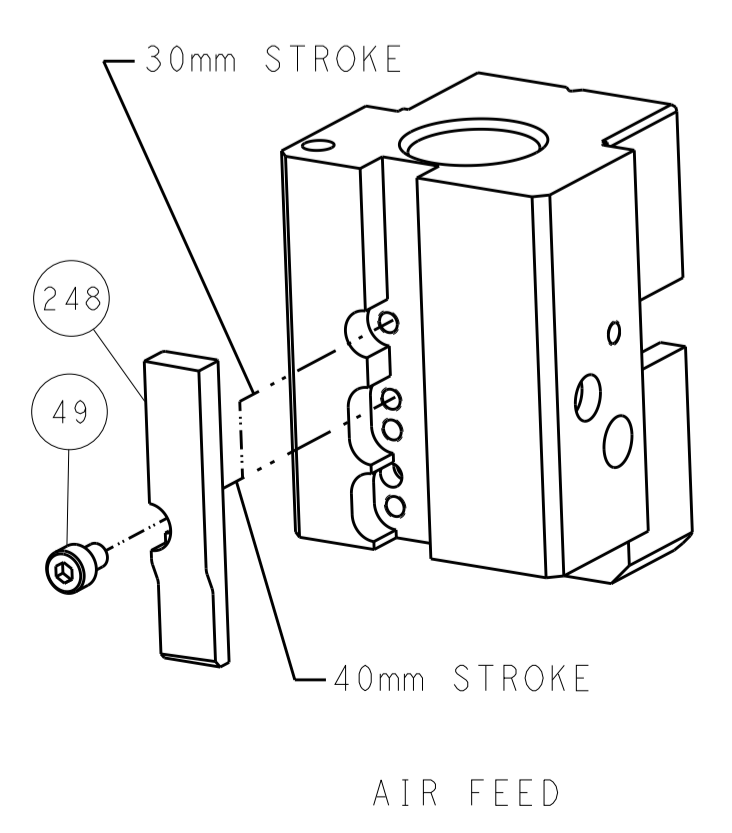

ATLANTIC VERSION  
 Shown on sheets 1 of 4 & 2 of 4  
 (Pacific version shown on sheets 3 of 4 & 4 of 4)

DIMENSIONS:		TOLERANCES UNLESS OTHERWISE SPECIFIED:		DWN		TE Connectivity	
mm	0 PLC ±0.5	1 PLC ±0.5	2 PLC ±0.13	3 PLC ±0.013	4 PLC ±0.001	Y. YIN	26MAR2013
	ANGLES ±0.001			CHK	G. BAILEY		26MAR2013
MATERIAL:	FINISH:			APVD	H. GUO		26MAR2013
				NAME		Ocean End Feed Applicator	
				SIZE		CAGE CODE DRAWING NO	
				WEIGHT		A11 00779 C=2150320	
				RESTRICTED TO		Customer Accessible Production Drawing	
				SCALE		1:1 SHEET 2 OF 4 REV A	

PACIFIC VERSION TERMINATOR INTERFACE ADAPTER	PART NUMBER	REVISION	DESCRIPTION	FEED TYPE
	2-2150320-2	A	FINE CRIMP HEIGHT ADJUST	PNEUMATIC
	2-2150320-5	A	FINE CRIMP HEIGHT ADJUST	SERVO LATCH PLATE <sup>4</sup>
	2-2150320-7	A	FINE CRIMP HEIGHT ADJUST	NONE
	7-2150320-7	A	CRIMP TOOLING KIT	-

APPLICATOR DATA		
CRIMP WIRE	SIZE	TYPE
4.06 mm [1.60]	F	
INSUL	5.60 mm [2.20]	F
APPL INSTRUCTIONS 408-10390		

TERMINAL DATA: TE TERMINAL		TE CRIMP SPECIFICATION
TERMINAL NAME: FASTIN-FASTION REC. SERIES 9.5		
WIRE STRIP LENGTH		INSULATION DIAMETER RANGE
6.60-7.20 mm [1.260-.283 IN]		4.00-5.10 mm [1.157-.201 IN]
TERMINAL APPLICATION SPECIFICATION	114-18022 <sup>1</sup>	
TERMINALS APPLIED		
TE TERMINAL	TE TERMINAL	TE TERMINAL
962833-1		

WIRE SIZE	CRIMP HEIGHT mm [INCH]	CRIMP HEIGHT REFERENCE SETTING <sup>9</sup>
6.00mm2	2.86 +/- 0.05 [1.113 +/- .002]	8.0
5.00mm2	2.68 +/- 0.05 [1.06 +/- .002]	9.8
4.00mm2	2.50 +/- 0.05 [1.098 +/- .002]	12.0

- RECOMMENDED SPARE PARTS
- GREASE BEARING SURFACES LIGHTLY
- 3. LUBRICATE DAILY PER THE APPLICATOR INSTRUCTION SHEET SUPPLIED WITH THE APPLICATOR.
- APPLICATOR SPECIFIC DATA TO BE ENTERED INTO BLANK MEMORY CHIP AT ASSEMBLY. SEE BELOW FOR PART NUMBER:  
PNEUMATIC FEED WITH "SMART APPLICATOR" CONVERSION: 8-2150320-4  
SERVO FEED WITH "FINE CRIMP HEIGHT ADJUST": 8-2150320-5
- 5. ADJUSTMENT OF THE STRIPPER MAY BE REQUIRED WHEN MOVING THE APPLICATOR BETWEEN BENCH AND LEADMAKER APPLICATIONS.
- APPLY PART NUMBER 1-23419-5 LOCTITE TO THREADS OF ITEMS 50, 62 & 242.
- GREASE THREADS, GROOVE AND O-RING ON ITEMS 139 & 153.
- MAGNET, ITEM 166 MUST BE ORIENTED CORRECTLY IN ORDER TO PROPERLY ACTUATE THE COUNTER.
- CRIMP HEIGHT REFERENCE SETTING WAS THE SETTING USED WHEN THE APPLICATOR WAS QUALIFIED AT THE FACTORY. ADJUSTMENT MAY BE NECESSARY WHEN RUNNING APPLICATOR IN THE FIELD.
- SPARE FEED CAM STORAGE LOCATION REFER TO INSTRUCTION SHEET FOR ADDITIONAL INFORMATION.
- PRODUCT SPECIFICATION (RE: TENSILE VALUES ETC) IS 108-18149-1

**\*WARNING**  
ON INSTALLATION, SET WIRE DISC, ITEM 40 TO LARGEST WIRE SIZE SETTING. USE OF SETTINGS BELOW MINIMUM REQUIRED CRIMP HEIGHT SETTING WILL CAUSE DAMAGE TO CRIMP TOOLING.

-	1	1	1	2119782-1	FINE ADJUST HEAD ASM, PACIFIC STYLE	251	
-	-	-	1	2119640-1	PUSH ROD, AIR FEED	250	
-	-	-	1	2079988-1	BUSHING, LCH5-12, MISUMI	249	
-	1	1	1	1-22279-3	SPRING, COMPRESSION	246	
-	1	1	1	2119082-9	CAM, SNAIL, INSULATION ADJUSTMENT	244	
-	1	1	1	2079764-1	WASHER, WAVE SPRING, CREST-TO-CREST	243	
-	77	27	25	22	PART NO	DESCRIPTION	ITEM NO

**PACIFIC VERSION**  
Shown on sheets 3 of 4 & 4 of 4  
(Atlantic version shown on sheets 1 of 4 & 2 of 4)

SET UP GAUGE	LOC	DIST	REVISIONS			
2119599-2	A	66	REV	DATE	BY	APPV
			-	SEE SHEET 1	-	-

	-	1	1	1	2119083-1	RETAINER, INSULATION DIAL	242	
	-	2	-	-	2168400-7	SHCS, LOW HEAD, RoHS, M5 X 10	240	
	-	-	-	-	2119580-1	MECHANICAL FEED ASSEMBLY	239	
	-	-	-	1	2063440-2	AIR FEED MODULE	238	
	-	-	1	-	2119740-2	TAG, IDENTIFICATION	213	
	-	4	4	4	2079383-9	SCR, BHSC, RoHS (M6 X 20)	186	
	-	REF	-	-	1901697-1	FEED FINGER ASSEMBLY, EF	183	
	-	1	1	1	6-993111-6	PIN, SLOTTED SPRING 3.0 X 14.0	177	
	-	1	1	1	8-22280-7	SPRING, COMPRESSION	176	
	-	1	1	1	1752353-2	GUIDE PIN, HOLDDOWN	175	
	-	1	1	1	1901680-2	GUIDE PIN, HOLDDOWN	174	
	-	-	-	2	21045-3	RING, RETAIN, EXTERN, 3/16 CRESCENT	172	
	-	1	1	1	994969-1	MAGNET, RARE EARTH HIGH ENERGY	166	
	-	REF	REF	REF	994970-2	COUNTER, MAGNETIC	164	
	-	-	-	1	240638-1	SPRING, FEED FINGER	163	
	-	1	1	1	8-21084-1	O-RING, .801 ID, .070 DIA. MAT.	153	
	-	-	-	1	2119641-2	FEED CAM, AIR FEED	152	
	-	1	1	1	2119798-2	DETENT PIN	145	
	-	1	1	1	2079383-8	SCR, BHSC, RoHS (M4 X 16)	144	
	-	1	1	1	2119655-6	APPLICATOR BASIC ASSEMBLY, EF	141	
	-	1	1	1	2119651-1	RAM, ASIAN STYLE, END FEED	140	
	-	1	1	1	2119092-2	BOLT, ADJUSTMENT	139	
	-	-	-	1	3-23627-7	PIN, RETAIN, GRVD, 3/16 X .854	137	
	-	REF	-	-	SEE NOTE 4	MEMORY CHIP, PROGRAMMED	135	
	-	-	-	1	1633743-1	SERVO FEED LATCH ASM	133	
	-	1	1	1	455888-4	SPACER, CRIMPER	82	
	-	1	1	1	2119791-9	DEPRESSOR, WIRE	73	
	-	1	1	1	2119956-2	DOCUMENTATION PACKAGE	71	
	-	2	2	2	2-18032-2	SCR, SET, FLT POINT M3 X 10.0	70	
	-	1	1	1	2119943-1	WASHER, SPACER	69	
	-	1	-	1	2119740-1	TAG, IDENTIFICATION	67	
	-	2	2	2	2168078-1	SCREW, DRIVE, RH, RoHS, 2 x .188	66	
	-	1	1	1	1901681-1	HOLDDOWN, TERMINAL	65	
	-	2	2	2	2168400-5	SHCS, LOW HEAD, RoHS, M4 X 20	64	
	-	1	1	1	2119793-1	LIMITER, ADJUSTMENT BOLT	63	
	-	3	3	3	992763-5	SCR, SET, SOC, CONE POINT, M3 X 4.0	62	
	-	-	-	-	2063961-1	FEED FINGER	58	
	-	3	3	3	2168400-1	SHCS, LOW HEAD, RoHS, M4 X 12	57	
	-	2	2	2	2168083-8	SCR, SKT HD CAP, RoHS, M4 X 16	56	
	-	2	2	2	5018030-2	NUT, HEX, REG, RoHS, M4	55	
	-	2	2	2	5018030-1	NUT, HEX, REG, RoHS, M3	54	
	-	2	2	2	986965-8	NUT, LOCK, HEX, TORQUE (M4)	53	
	-	1	1	1	1-5018030-0	NUT, HEX, REG, RoHS, M3.5	52	
	-	-	-	1	2119792-2	PAWL, EF, AIR	51	
	-	1	1	1	1-1752354-5	STANDOFF, HOLD-DOWN	50	
	-	-	-	1	18023-9	SCR, SKT HD CAP M4 X 6.0	49	
	-	1	1	1	2079383-7	SCR, BHSC, RoHS (M8 X 25)	41	
	-	1	1	1	2119645-1	DISC, NUMBERED FA WIRE ADJUSTMENT	40	
	-	1	1	1	2119957-1	APPLICATOR SHIM PACK	39	
	-	1	1	1	2119644-2	RAM WASHER, PRECISION	38	
	-	7	7	7	1-18028-2	WASHER, FLAT, REG M4	33	
	-	2	2	2	2168083-9	SCR, SKT HD CAP, RoHS, M4 X 20	31	
	-	2	2	2	1-2168083-0	SCR, SKT HD CAP, RoHS, M4 X 10	29	
	-	1	1	1	690455-3	STRIPPER, FRONT CASTING	27	
	-	2	2	2	1320906-1	STUD, THREADED	25	
	-	1	1	1	1-1752371-5	PLATE, STRIP GUIDE	24	
	-	1	1	1	240825-1	PLATE, STRIP HOLD DOWN	23	
	-	2	2	2	2-22281-3	SPRING, COMPRESSION	22	
	-	1	1	1	1752373-4	DRAG	20	
	-	2	2	2	1901259-8	GUIDE, LOWER STRIP	18	
	-	1	1	1	2-240641-4	SPACER	16	
	-	1	1	1	1752360-1	SPACER, HOLD-DOWN	13	
	-	1	1	1	240833-3	PLATE, REAR SHEAR	11	
	-	-	-	-	-	-	10	
	-	1	1	1	690482-5	PLATE, FRONT SHEAR	9	
	1	1	1	1	1333223-9	ANVIL, COMBINATION	8	
	-	1	1	1	2217206-7	BLADE, SLUG	7	
	-	-	-	-	-	-	6	
	-	1	1	1	2-240641-7	SPACER	5	
	-	1	1	1	2-238009-9	BLOCK, FL CRIMPER SPACER	4	
	1	1	1	1	7-2119582-4	CRIMPER, INSULATION F PREMIUM	3	
	-	1	1	1	455888-5	SPACER, CRIMPER	2	
	1	1	1	1	1-456414-2	CRIMPER, WIRE	1	
	-	77	27	25	22	PART NO	DESCRIPTION	ITEM NO

DIMENSIONS:		TOLERANCES UNLESS OTHERWISE SPECIFIED:		DRAWING NO	
mm	0 PLC ±.5	1 PLC ±.5	2 PLC ±.5	3 PLC ±.5	4 PLC ±.5
	ANGLES ±.0001				
MATERIAL	FINISH	WEIGHT	SCALE	SHEET	REV
			1:1	3 OF 4	A

LOC		DIST		REVISIONS			
A	66	P	LTM	DESCRIPTION	DATE	OWN	APVD
		-	-	SEE SHEET 1	-	-	-

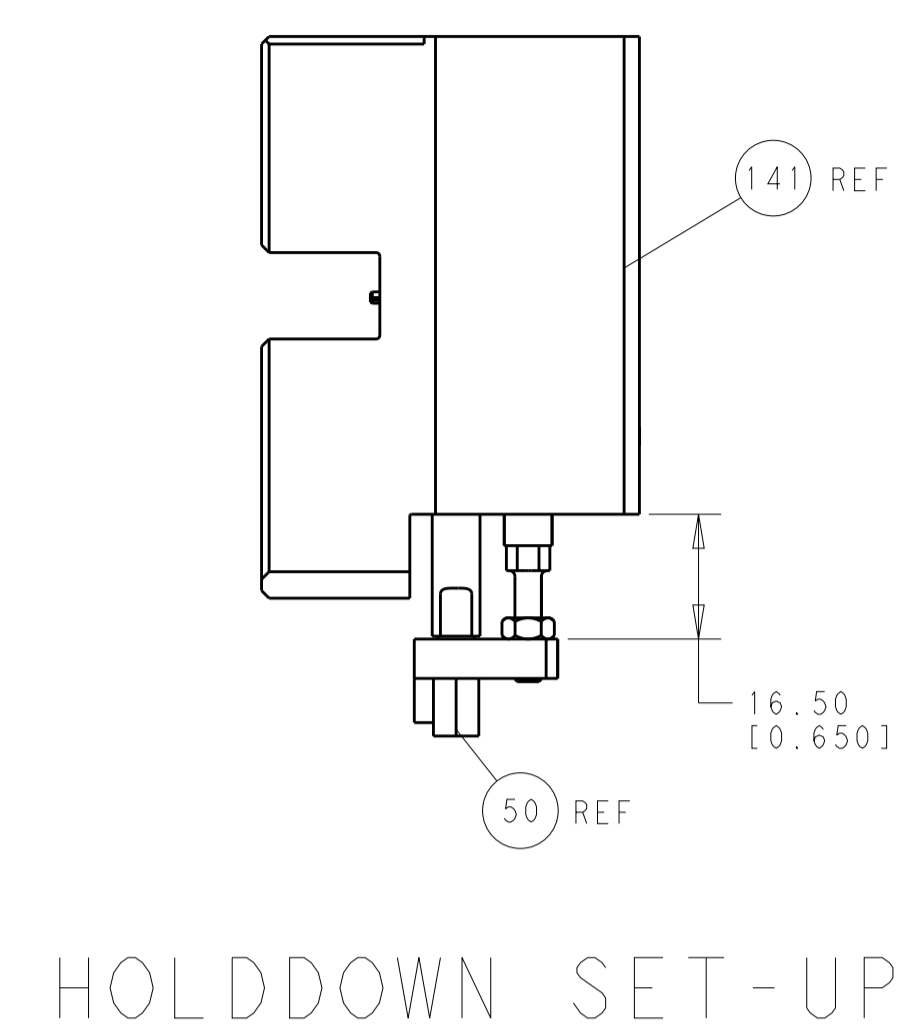

FEED TYPE

PNEUMATIC

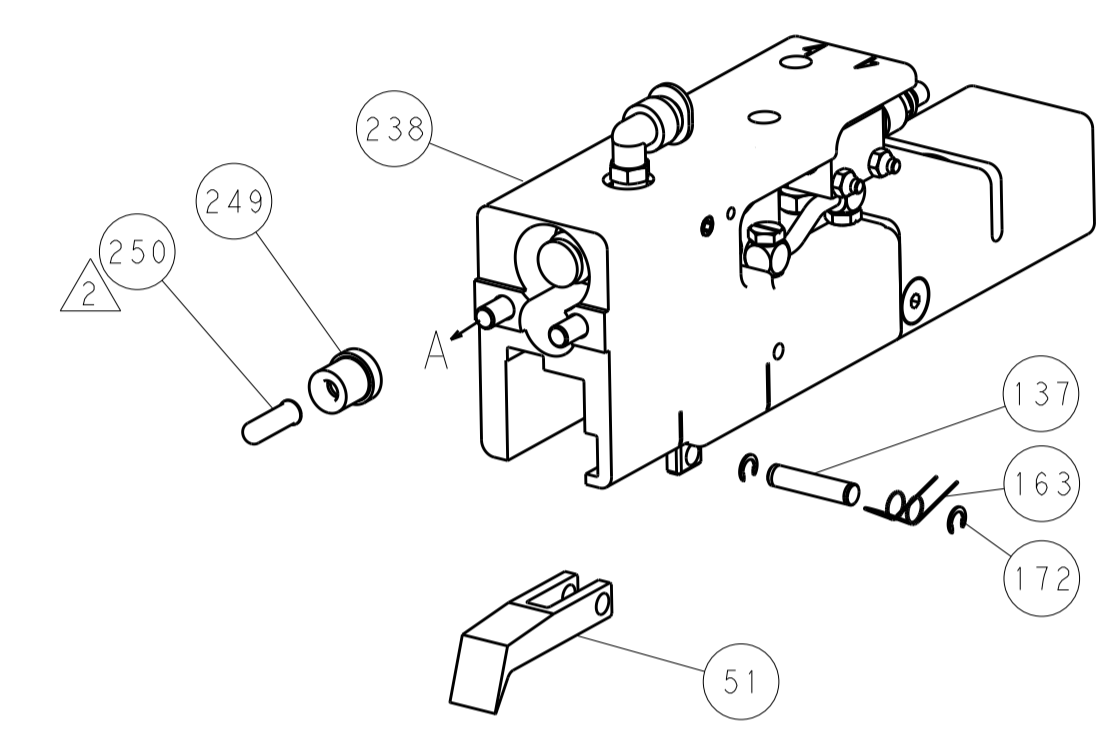

SERVO LATCH PLATE

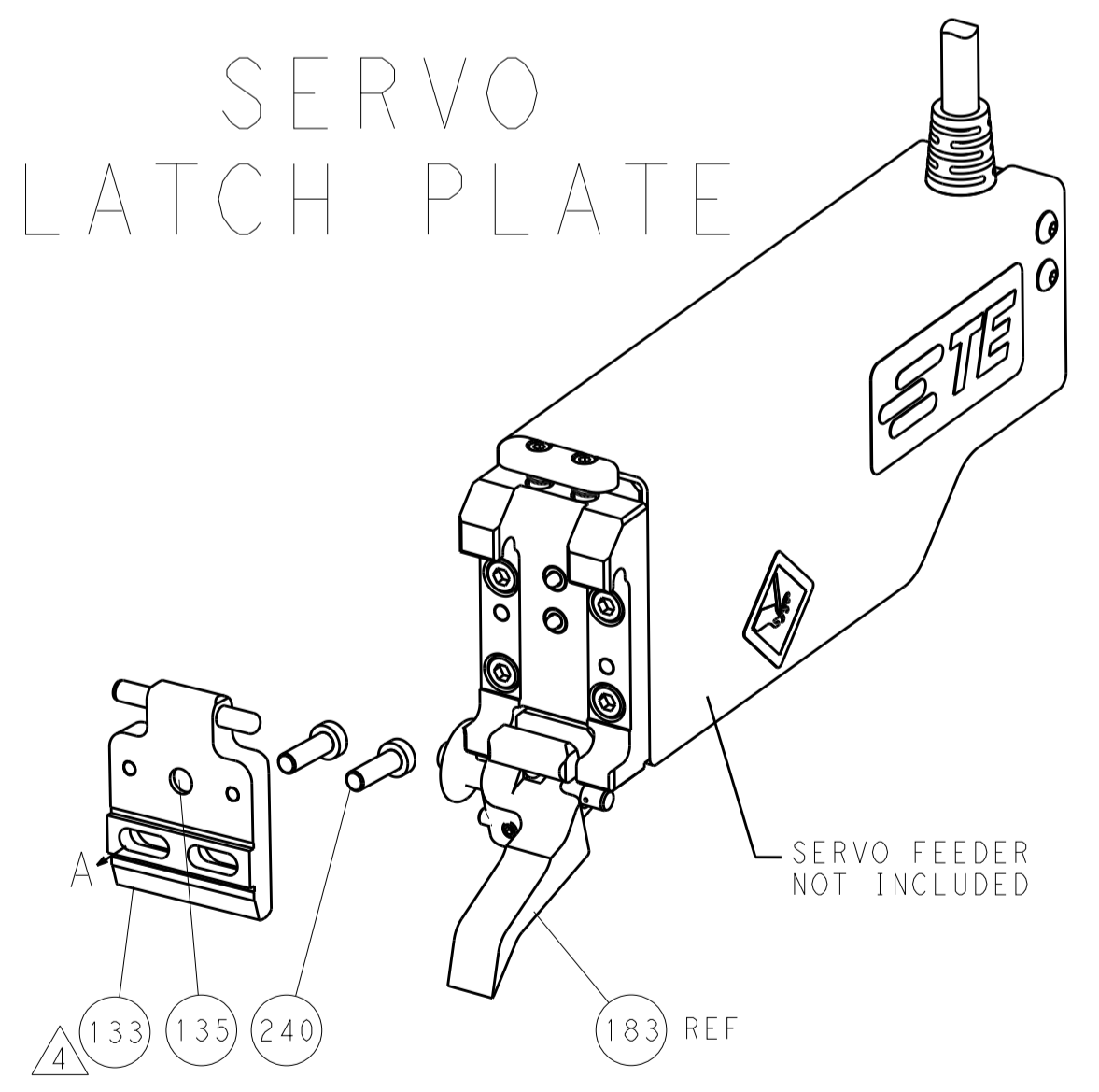

CAM POSITION

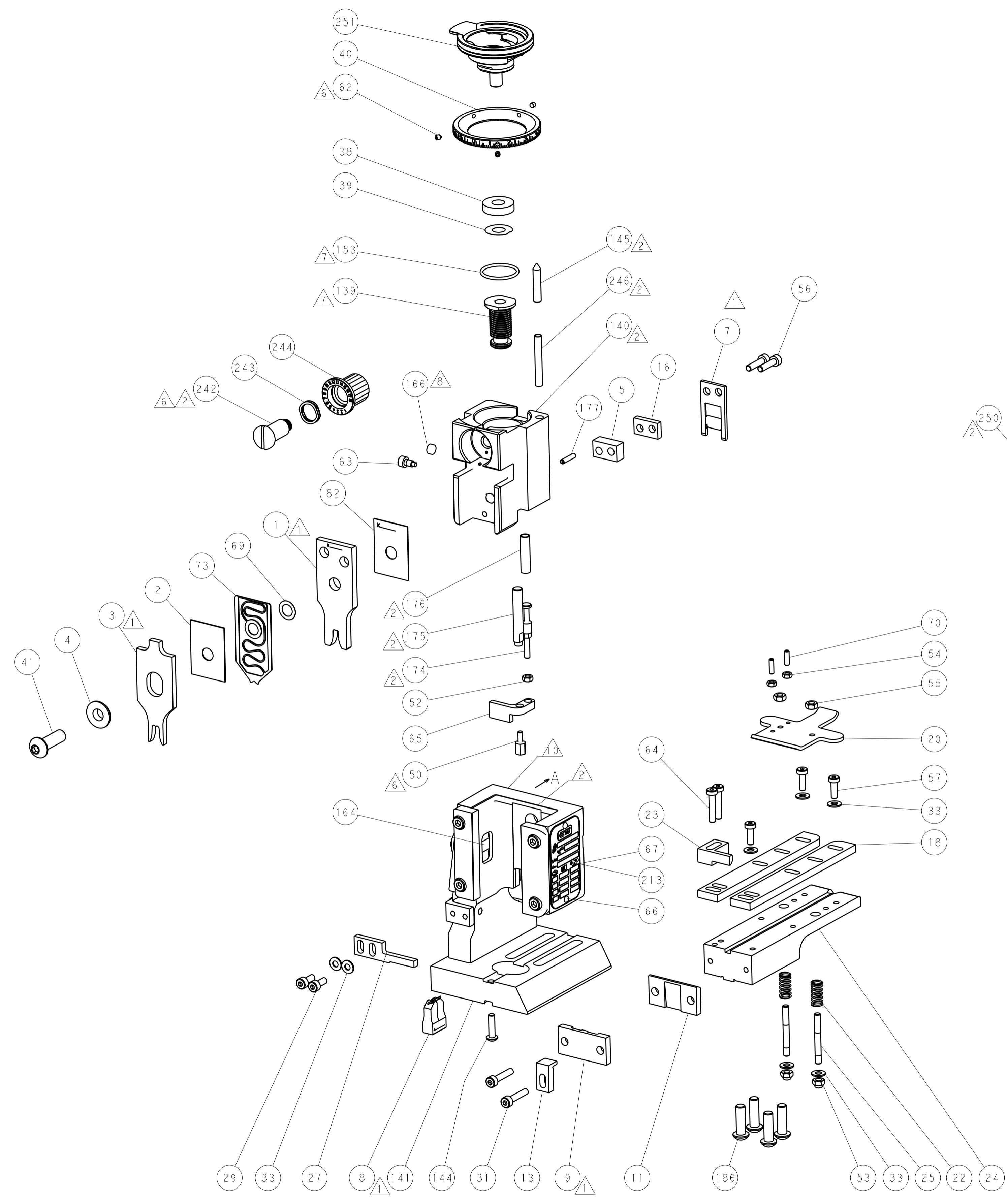
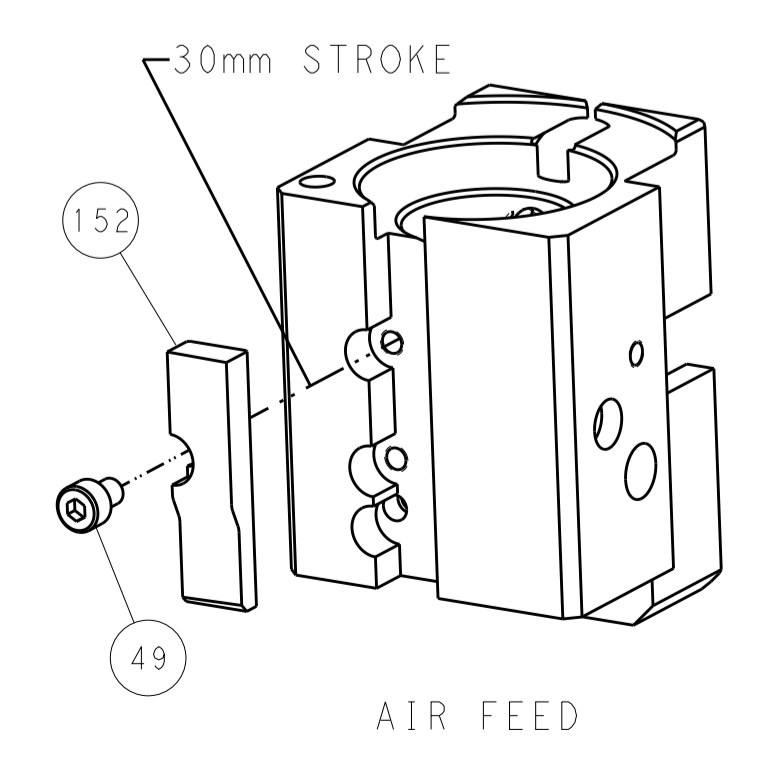

PACIFIC VERSION  
 Shown on sheets 3 of 4 & 4 of 4  
 (Atlantic version shown on sheets 1 of 4 & 2 of 4)

DIMENSIONS:		TOLERANCES UNLESS OTHERWISE SPECIFIED:		OWN: Y. YIN 26MAR2013		STE Connectivity	
mm	0 PLC ±0.5	1 PLC ±0.5	2 PLC ±0.13	3 PLC ±0.013	4 PLC ±0.001	ANGLES ±0.001	TE Connectivity Harrisburg, PA 17105-3608
MATERIAL:	FINISH:	WEIGHT:	SCALE:	APVD: G. BAILEY 26MAR2013	NAME: Ocean End Feed Applier	SIZE: A1	CAGE CODE: 00779
Customer Accessible Production Drawing				SCALE: 1:1	SHEET: 4	OF: 4	REV: A