

HYBRID - HIGH RELIABILITY RADIATION HARDENED DC-DC CONVERTER

Description

The M3GB-Series of DC-DC converters are second generation design of the legacy M3G-Series product family but with enhanced overall performance. M3GB-Series is form, fit and functional equivalent to the first generation M3G-Series. It is designed to be backward compatible to the M3G-Series with the addition of an output voltage adjustment pin for the single output models. Much the same as the original M3G-Series, these converters are radiation hardened, high reliability converters designed for extended operation in hostile environments. Their small size and low weight make them ideal for applications such as geostationary earth orbit satellites and deep space probes. They exhibit a high tolerance to total ionizing dose, single event effects and environmental stresses such as temperature extremes, mechanical shock, and vibration.

The converters incorporate a fixed frequency single ended forward topology with magnetic feedback and an internal EMI filter that utilizes multilayer ceramic capacitors that are subjected to extensive lot screening for optimum reliability. These converters are capable of meeting the conducted emissions and conducted susceptibility requirements of MIL-STD-461C without any additional components. External inhibit and synchronization input and output allow these converters to be easily incorporated into larger power systems. They are enclosed in a hermetic 3" x 2" x 0.475" package constructed of an Aluminum/Silicon-Carbide (Al/SiC) base and an Alloy 48 ring frame and they weigh less than 110 grams. The package utilizes rugged ceramic feed-through copper core pins and is sealed using parallel seam welding.

Manufactured in a facility fully qualified to MIL-PRF-38534, these converters are fabricated utilizing DLA Land and Maritime qualified processes. For available screening options, refer to device screening table in the data sheet.

Non-flight versions of the M3GB-Series converters are available for system development purposes. Variations in electrical specifications and screening to meet custom requirements can be accommodated.

www.irf.com

M3GB-SERIES

28V Input, Single/Dual Output

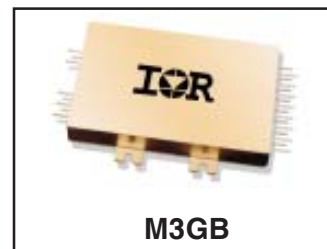

Features

- Total Dose > 200 kRads(Si), typically usable to > 300 kRads(Si)
- SEE Hardened to LET up to 82 MeV.cm²/mg
- Internal EMI filter; Converter Capable of meeting MIL-STD-461C CE03
- Low Weight, < 110 grams
- Magnetically Coupled Feedback
- 18V to 50V DC Input Range
- Up to 40W Output Power
- Single and Dual Output Models Include 3.3, 5, 5.2, 12, 15, ±5, ±7, ±12 and ±15V
- High Efficiency - to 83%
- -55°C to +125°C Operating Temperature Range
- 100MΩ @ 100VDC Isolation
- Under-Voltage Lockout
- Short Circuit and Overload Protection
- Remote Sense on Single Output Models
- Adjustable Output Voltage for all Models
- Synchronization Input and Output
- External Inhibit
- > 7,000,000 hour MTBF

Applications

- Geostationary Earth Orbit Satellites (GEO)
- Deep Space Satellites / Probes
- Strategic Weapons and Communication System

M3GB-SERIES (28V Input, Single/Dual Output)

Circuit Description

The M3GB-Series converters utilize a single-ended forward topology with resonant reset. The nominal switching frequency is 500kHz. Electrical isolation and tight output regulation are achieved through the use of a magnetically coupled feedback. Voltage feed-forward with duty factor limiting provides high line rejection and protection against output over voltage in the event of an internal control loop failure. This mechanism limits the maximum output voltage to approximately 30% over the nominal regardless of the line voltage.

An internal EMI filter allows the converter to meet the conducted emissions requirements of MIL-STD-461C on the input power leads. A two-stage output filter reduces the typical output ripple to less than 20mV peak-to-peak.

Output current is limited under any load fault condition to approximately 125% of rated. An overload condition causes the converter output to behave like a constant current source with the output voltage dropping below nominal. The converter will resume normal operation when the load current is reduced below the current limit point. This protects the converter from both overload and short circuit conditions.

An under-voltage lockout circuit prohibits the converter from operating when the line voltage is too low to maintain the output voltage. The converter will not start until the line voltage rises to approximately 16.5 volts and will shut down when the input voltage drops below 15.3 volts. The 1.2V of hysteresis reduces the possibility of line noise interfering with the converter's start-up and shut down.

An external inhibit port is provided to control converter operation. The nominal threshold relative to the input return (pin 2) is 1.4V. If 2.0 volts or greater are applied to the Inhibit pin (pin 3) then the converter will operate normally. A voltage of 0.8V or less will cause the converter to shut-down. The pin may be left open for normal operation and has a nominal open circuit voltage of 4.0V.

Synchronization input and output allow multiple converters to operate at a common switching frequency. Converters can be synchronized to one another or to an externally provided clock. This can be used to eliminate beat frequency noise or to avoid creating noise at certain frequencies for sensitive systems.

Remote sense is provided on the single output models to compensate for voltage drops in the interconnects between the converter and the load. The output voltage of dual output models can be adjusted by a single external resistor.

Design Methodology

The M3GB-Series was developed using a proven conservative design methodology which includes selecting radiation tolerant and established reliability components and fully derating to the requirements of MIL-STD-1547 and MIL-STD-975 (except for the CDR type ceramic capacitors, where capacitors with 50V ratings may be used with voltage stresses of less than 10V). Careful sizing of decoupling capacitors and current limiting resistors minimizes the possibility of photo-current burn-out. Heavy derating of the radiation hardened power MOSFET virtually eliminates the possibility of SEGR and SEB. A magnetic feedback circuit is utilized instead of opto-couplers to minimize temperature, radiation and aging sensitivity. PSPICE and RadSPICE were used extensively to predict and optimize circuit performance for both beginning and end-of-life. Thorough design analyses include Radiation Susceptibility (TREE), Worst Case, Stress, Thermal, Failure Modes and Effects (FMEA) and Reliability (MTBF).

Specifications

Absolute Maximum Ratings		Recommended Operating Conditions	
Input voltage range	-0.5V _{DC} to +80V _{DC} ³	Input voltage range	+18V _{DC} to +60V _{DC}
Output power	Internally limited	Input voltage range ¹	+18V _{DC} to +45V _{DC}
Lead temperature	+300°C for 10 seconds	Output power	0 to Max. Rated
Operating temperature	-55°C to +135°C	Operating temperature ²	-55°C to +125°C
Storage temperature	-55°C to +135°C	Operating temperature ¹	-55°C to +70°C

¹ Meets derating per MIL-STD-975

² For operation at +125°C see table Note 13

³ Max voltage is 75V for 5V models

Electrical Performance Characteristics

Parameter	Group A Subgroup	Conditions -55°C ≤ T _C ≤ +85°C V _{IN} = 28V DC ± 5%, C _L = 0 unless otherwise specified	Limits			Unit
			Min	Nom	Max	
Input Voltage (V _{IN})			18	28	50	V
Output Voltage (V _{OUT})						
M3GB2803R3S	1	I _{OUT} = 100% rated load Note 4	3.29	3.31	3.33	V
M3GB2805S	1		4.99	5.01	5.03	
M3GB2805R2S	1		5.19	5.21	5.23	
M3GB2812S	1		11.95	12.00	12.05	
M3GB2815S	1		14.94	15.00	15.06	
M3GB2805D	1		±4.99	±5.01	±5.03	
M3GB2807D	1		±6.97	±7.00	±7.03	
M3GB2812D	1		±11.95	±12.00	±12.05	
M3GB2815D	1		±14.94	±15.00	±15.06	
M3GB2803R3S	2,3	I _{OUT} = 100% rated load Note 4	3.26		3.34	
M3GB2805S	2,3		4.95		5.05	
M3GB2805R2S	2,3		5.15		5.25	
M3GB2812S	2,3		11.88		12.12	
M3GB2815S	2,3		14.85		15.15	
M3GB2805D	2,3		±4.95		±5.05	
M3GB2807D	2,3		±6.93		±7.07	
M3GB2812D	2,3		±11.88		±12.12	
M3GB2815D	2,3		±14.85		±15.15	
Output power (P _{OUT})						
M3G2803R3S	1,2,3	V _{IN} = 18, 28, 50 Volts, Note 2	0		30	W
All Others			0		40	
Output current (I _{OUT})						
M3GB2803R3S	1,2,3	V _{IN} = 18, 28, 50 Volts, Note 2	0		9.10	A
M3GB2805S			0		8.00	
M3GB2805R2S			0		7.70	
M3GB2812S			0		3.34	
M3GB2815S			0		2.67	
M3GB2805D		Either Output, Note 3	0		6.40	
M3GB2807D		Either Output, Note 3	0		4.57	
M3GB2812D		Either Output, Note 3	0		2.67	
M3GB2815D		Either Output, Note 3	0		2.14	
Line regulation (VR _{LINE})						
	1,2,3	V _{IN} = 18, 28, 50 Volts I _{OUT} = 0, 50%, 100% rated, Note 4	-10 -20		10 20	mV
	Single Dual					
Load regulation (VR _{LOAD})						
	1,2,3	I _{OUT} = 0, 50%, 100% rated, Note 4 V _{IN} = 18, 28, 50 Volts	-0.5		0.5	%

For Notes to Specifications, refer to page 5

M3GB-SERIES
(28V Input, Single/Dual Output)

Electrical Performance Characteristics (continued)

Parameter	Group A Subgroup	Conditions -55°C ≤ T _C ≤ +85°C V _{IN} = 28V DC ± 5%, C _L = 0 unless otherwise specified	Limits			Unit
			Min	Nom	Max	
Cross regulation (V _R CROSS) M3GB2805D M3GB2807D M3GB2812D M3GB2815D	1,2,3	Duals only, Note 5 V _{IN} = 18, 28, 50 Volts	-5.0 -4.0 -2.0 -2.0		5.0 4.0 2.0 2.0	%
Input current (I _{IN})	1,2,3	I _{OUT} = 0, Pin 3 open		50	80	mA
		Pin 3 shorted to Pin 2		2.0	5.0	
Switching frequency (F _S)	1,2,3	Sync. Input (Pin 4) open	475	500	525	kHz
Output ripple (V _{RIP}) M3GB2803R3S M3GB2805S M3GB2805R2S M3GB2812S M3GB2815S M3GB2805D M3GB2807D M3GB2812D M3GB2815D	1,2,3	I _{OUT} = 100% rated load Notes 4, 6		15 20 25 25 25 20 25 30 30	35 50 50 60 80 50 55 60 60	mV p-p
Efficiency (E _{FF}) M3GB2803R3S M3GB2805S M3GB2805R2S M3GB2812S M3GB2815S M3GB2805D M3GB2807D M3GB2812D M3GB2815D	1,2,3	I _{OUT} = 100% rated load Note 4	72 78 78 77 77 78 78 77 78	75 80 80 80 81 80 80 81 82		%
Enable/Inhibit Input open circuit voltage drive current (sink) voltage range		Note 1	3.0 -0.5		5.0 100 50	V μA V
Synchronization Input frequency range pulse high level pulse low level pulse transition time pulse duty cycle		Ext. Clock on Sync. Input (Pin 4) Note 1	450 4.0 -0.5 40 20		600 10 0.5 80	kHz V V V/μs %
Current Limit Point Expressed as a percentage of full rated load current	1,2,3	V _{OUT} = 90% of Nominal, Note 4	118	125	130	%
Power dissipation, load fault (P _D)	1,2,3	Short Circuit, Overload, Note 8		12	18	W
Output response to step load changes (V _{TLD})	4,5,6	Half Load to/from Full Load, Notes 4, 9	-300		300	mVpk
Recovery time, step load changes (T _{TLD})	4,5,6	Half Load to/from Full Load, Notes 4, 9,10		50	200	μs
Output response to step line changes (V _{TLN})		22V to/from 34V I _{OUT} = 100% rated load, Notes 1,4,11	-200		200	mV pk
Recovery time, step line changes (T _{TLN})		22V to/from 34V I _{OUT} = 100% rated load, Notes 1,4,10,11		50	200	μs
Turn-on Response Overshoot (V _{OS}) Turn-on Delay (T _{DLY})	4,5,6	No Load, Full Load Notes 4,12	1.0		2.0 5.0	% ms

For Notes to Specifications, refer to page 5

Electrical Performance Characteristics (continued)

Parameter	Group A Subgroup	Conditions $-55^{\circ}\text{C} \leq T_C \leq +85^{\circ}\text{C}$ $V_{IN} = 28\text{V DC} \pm 5\%$, $C_L = 0$ unless otherwise specified	Limits			Unit
			Min	Nom	Max	
Capacitive Load (C_L) M3GB2803R3S M3GB2805S M3GB2805R2S M3GB2812S M3GB2815S M3GB2805D M3GB2807D M3GB2812D M3GB2815D		$I_{OUT} = 100\%$ rated load No effect on DC performance Notes 1, 4, 7 Each output on duals			2200 1000 1000 180 120 500 300 90 60	μF
Line Rejection		$I_{OUT} = 100\%$ rated load DC to 50kHz, Notes 1, 4	40	50		dB
Isolation	1	Input to Output or Any Pin to Case except Pin 6, test @ 100VDC	100			M Ω
Device Weight					110	g
MTBF		MIL-HDBK-217F2, SF, 35 $^{\circ}\text{C}$	7.0×10^6			Hrs

Notes: Electrical Performance Characteristics Table

- Parameter is guaranteed to the limits specified in table by design, but not tested. Limits apply to the operating range specified in table, unless otherwise specified. No Group A subgroups are specified for this test.
- Parameter verified during line and load regulation tests.
- Limit represents 80% of total rated output current. To achieve rated output power, the remaining 20% of the total rated output current must be provided by the other output.
- Load current split equally between outputs on dual output models.
- Cross regulation is measured with 20% rated load on output under test while changing the load on the other output from 20% to 80% of rated.
- Guaranteed for a D.C. to 20MHz bandwidth. Tested using a 20kHz to 10MHz bandwidth.
- Capacitive load may be any value from 0 to the maximum limit without compromising dc performance. A capacitive load in excess of the maximum limit may interfere with the proper operation of the converter's overload protection, causing erratic behavior during turn-on.
- Overload power dissipation is defined as the device power dissipation with the load set such that $V_{OUT} = 90\%$ of nominal.
- Load step transition time $\geq 10 \mu\text{s}$.
- Recovery time is measured from the initiation of the transient to where V_{OUT} has returned to within $\pm 1\%$ of its steady state value.
- Line step transition time $\geq 100 \mu\text{s}$.
- Turn-on delay time from either a step application of input power or a logic low to a logic high transition on the inhibit pin (Pin 3) to the point where $V_{OUT} = 90\%$ of nominal.
- For operation at temperatures between $+85^{\circ}\text{C}$ and $+125^{\circ}\text{C}$, derate the maximum input voltage linearly from 60V to 40V and the maximum output power linearly from 100% to 75%.

Fig 3. Typical Conducted Emissions, Positive Lead



Fig 4. Typical Line Rejection

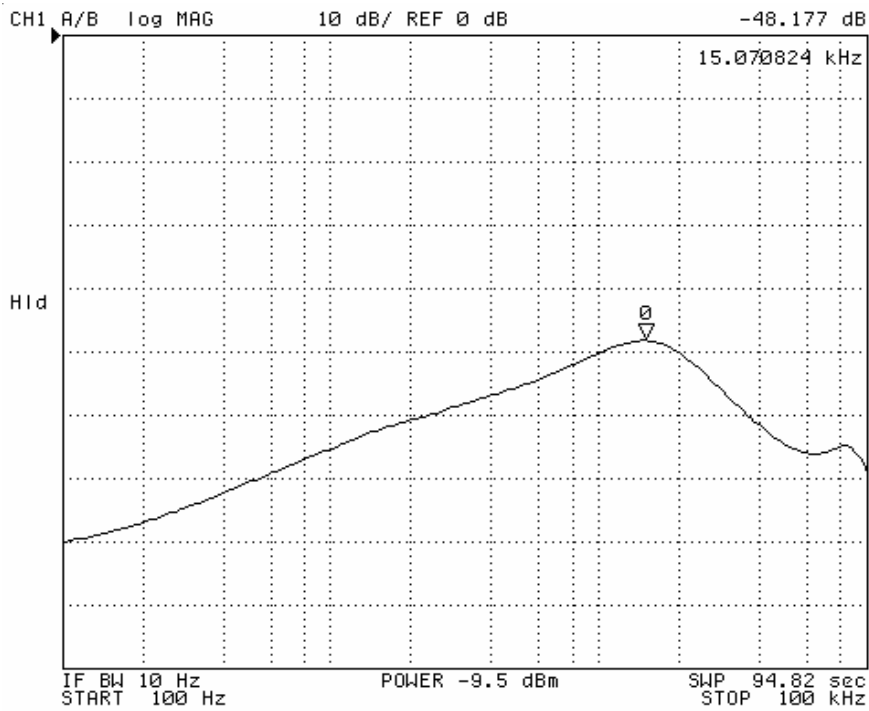

Fig 5. Typical Efficiency @25°C, M3GB2805S

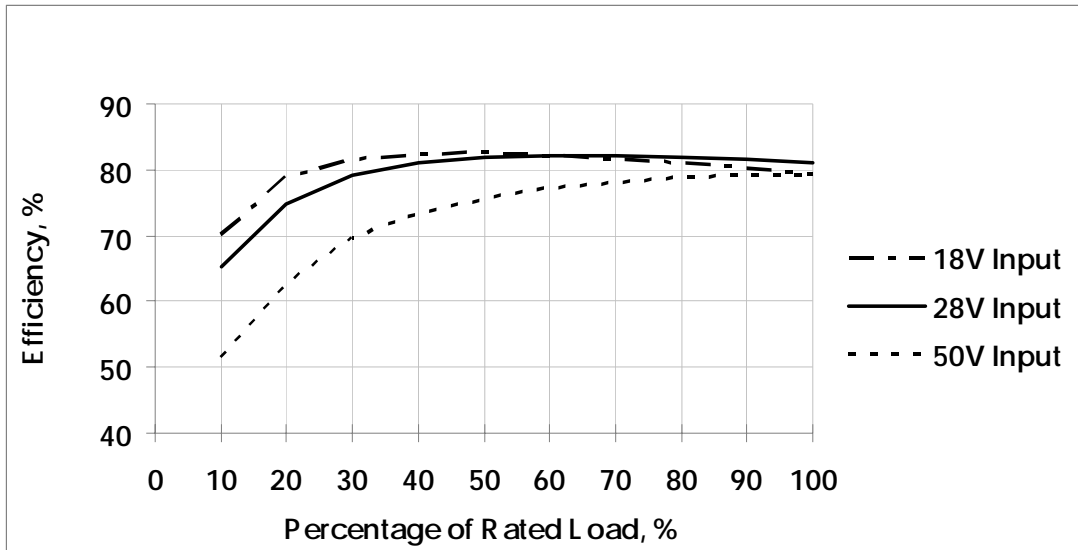
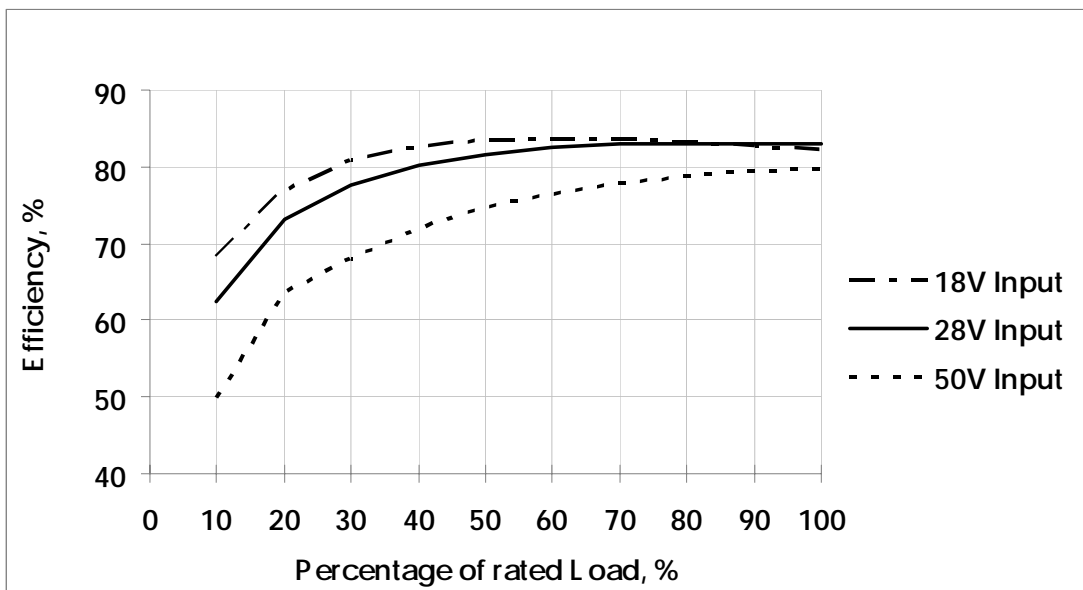

Fig 6. Typical Efficiency @25°C, M3GB2815D



Radiation Performance Characteristics

Test	Method	Min	Typ	Unit
Total Ionizing Dose (Gamma)	MIL-PRF-883, Method 1019 Operating bias applied during exposure, Full Rated Load, $V_{IN} = 28V$	200	300	kRads(Si)
Dose Rate (Gamma Dot) Temporary Saturation Survival	MIL-STD-883, Method 1023 Operating bias applied during exposure, Full Rated Load, $V_{IN} = 28V$ (Supported by Analysis)	1E8 4E10	1E11	Rads(Si)/sec
Neutron Fluence	MIL-STD-883, Method 1017 (Supported by Analysis)	8E12	1E13	Neutrons/cm ²
Single Event Effects SEU, SEL, SEGR, SEB	Heavy Ions (LET) Operating bias applied during exposure, Full Rated Load, $V_{IN} = 18V, 28V, 50V$	82		MeV·cm ² /mg

Application Notes:

A) Attachment of the Converter.

The following procedure is recommended for mounting the converter for optimum cooling and to circumvent any potential damage to the converter.

Ensure that flatness of the plate where M3GB converter to be mounted is no greater than 0.003" per linear inch. It is recommended that a thermally conductive gasket is used to promote the thermal transfer and to fill any voids existing between the two surfaces. IR recommends Sil-Pad 2000 with the thickness of 0.010". The shape of the gasket should match the footprint of the converter including the mounting flanges. The gasket is available from IR. The M3GB-Series converter requires either M3 or 4-40 size screws of attachment purposes.

The procedure for mounting the converter is as follows:

1. Check the mounting surfaces and remove foreign material, burrs if any or anything that may interfere with the attachment of the converter.
2. Place the gasket on the surface reserved for the converter and line it up with the mounting holes.
3. Place the converter on the gasket and line both up with mounting holes.
4. Install screws using appropriate washers and tighten by hand (~ 4 in-oz) in the sequence shown below.

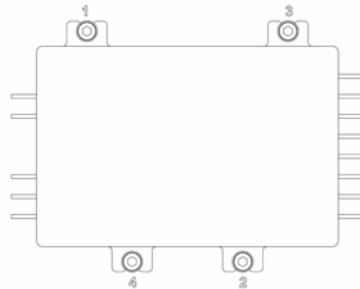

5. Tighten the screws with an appropriate torque driver. Torque the screws up to 6 in-lb in the sequence shown above.

M3GB-SERIES
(28V Input, Single/Dual Output)

B) Output Voltage Adjustment.

Single Output:

To adjust the output voltage of the single output models, a resistor (R_{ADJ}) is connected between the Adjust pin (Pin 8) and either the positive or negative remote sense pins, depending on whether the output voltage is to be adjusted higher or lower than the nominal set-point. This allows the outputs to be reliably adjusted by approximately +10% to -20% of the nominal output voltage. Refer to Fig. 7 and use equations provided to calculate the required resistance (R_{ADJ}).

Fig 7. Configuration for Adjusting Single Output Voltage

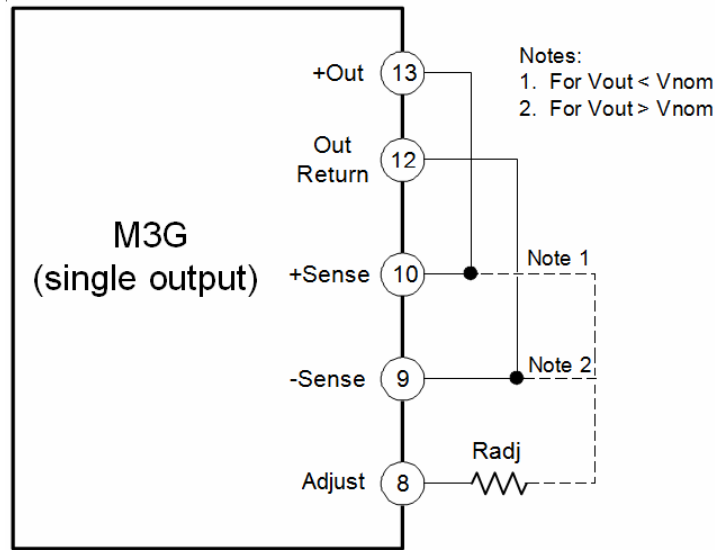

For **all Single Output Models**, to adjust the output voltages higher:

$$R_{ADJ} = \frac{10 \times (V_{NOM} - 2.5)}{V_{OUT} - V_{NOM}} - 50$$

Where: R_{ADJ} is in kOhms

R_{ADJ} is connected to the -Out pin and $V_{NOM} < V_{OUT} < 1.1V_{NOM}$ (Fig. 7, Note 2)

V_{NOM} is the nominal output voltage with the Adjust Pin left open

V_{OUT} is the desired output voltage

For **all Single Output Models**, to adjust the output voltages lower:

$$R_{ADJ} = \frac{4 \times (V_{NOM} - 2.5) \times (V_{OUT} - 2.5)}{V_{NOM} - V_{OUT}} - 50$$

Where: R_{ADJ} is in kOhms

R_{ADJ} is connected to the +Out pin and $0.8V_{NOM} < V_{OUT} < V_{NOM}$ (Fig. 7, Note 1)

V_{NOM} is the nominal output voltage with the Adjust Pin left open

V_{OUT} is the desired output voltage

Dual Output:

The dual output voltage of the dual output models, a resistor (R_{ADJ}) is connected between the Adjust pin (Pin 8) and either output. This allows the outputs to be reliably adjusted by approximately +10% to -20% of the nominal output voltage. Refer to Fig. 8 and use equations provided to calculate the required resistance (R_{ADJ}).

Fig. 8. Configuration for Adjusting Dual Output Voltage

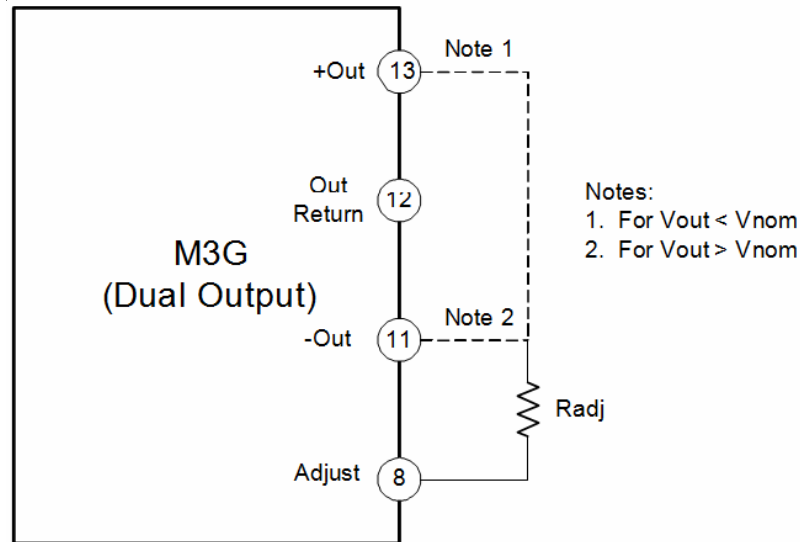

For **all Dual Output Models**, to adjust the output voltages higher:

$$R_{ADJ} = \frac{10 \times (V_{NOM} - 1.25)}{V_{OUT} - V_{NOM}} - 75$$

Where: R_{ADJ} is in kOhms
 R_{ADJ} is connected to the -Out pin and $V_{NOM} < V_{OUT} < 1.1V_{NOM}$ (Fig. 8, Note 2)
 V_{NOM} is the nominal magnitude of the output voltages with the Adjust pin left open
 V_{OUT} is the desired magnitude of the output voltages

For **all Dual Output Models**, to adjust the output voltages lower:

$$R_{ADJ} = \frac{8 \times (V_{NOM} - 1.25) \times (V_{OUT} - 1.25)}{V_{NOM} - V_{OUT}} - 75$$

Where: R_{ADJ} is in kOhms
 R_{ADJ} is connected to the +Out pin and $0.8V_{NOM} < V_{OUT} < V_{NOM}$ (Fig. 8, Note 1)
 V_{NOM} is the nominal magnitude of the output voltages with the Adjust pin left open
 V_{OUT} is the desired magnitude of the output voltages

M3GB-SERIES
(28V Input, Single/Dual Output)

Mechanical Diagram

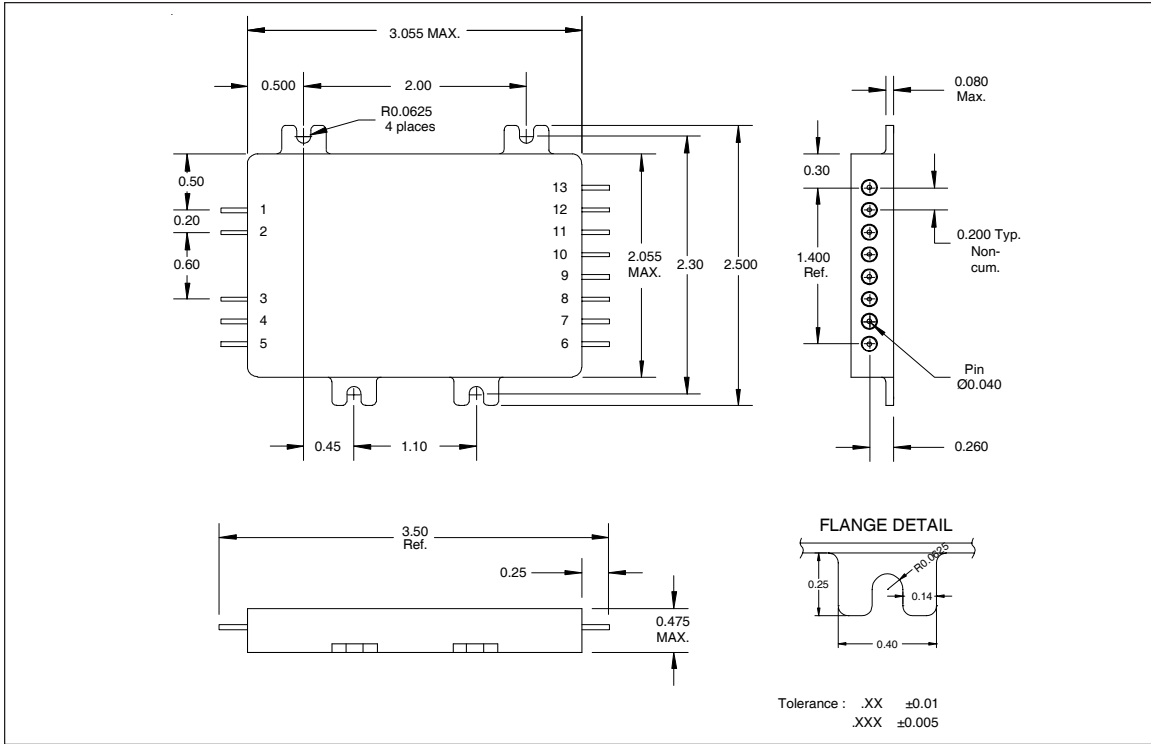

Pin Designation (Single/Dual)

Pin #	Designation	Pin #	Designation
1	+ Input	8	Adjust
2	Input Return	9	- Sense / NC
3	Inhibit	10	+ Sense / NC
4	Sync. Input	11	NC / - Output
5	Sync. Output	12	Output Return
6	Case Ground	13	+ Output
7	NC		

Device Screening

Requirement	MIL-STD-883 Method	No Suffix ②	CK ②	EM
Temperature Range	—	-55°C to +85°C	-55°C to +85°C	-55°C to +85°C
Element Evaluation	MIL-PRF-38534	Class K	Class K	N/A
Non-Destructive Bond Pull	2023	Yes	Yes	N/A
Internal Visual	2017	Yes	Yes	①
Temperature Cycle	1010	Cond C	Cond C	Cond C
Constant Acceleration	2001, Y1 Axis	3000 Gs	3000 Gs	3000 Gs
PIND	2020	Cond A	Cond A	N/A
Burn-In	1015	320 hrs @ 125°C (2 x 160 hrs)	320 hrs @ 125°C (2 x 160 hrs)	48 hrs @ 125°C
Final Electrical (Group A)	MIL-PRF-38534 & Specification	-55°C, +25°C, +85°C	-55°C, +25°C, +85°C	-55°C, +25°C, +85°C
PDA	MIL-PRF-38534	2%	2%	N/A
Seal, Fine and Gross	1014	Cond A, C	Cond A, C	Cond A
Radiographic	2012	Yes	Yes	N/A
External Visual	2009	Yes	Yes	①

Notes:

- ① Best commercial practice.
- ② CK is a DLA Land and Maritime (formerly DSCC) part marking used to designate a Class K compliant hybrid. The CK marking does not indicate the hybrid is radiation certified.
 No Suffix is a radiation rated device but not available as a DLA Land and Maritime qualified SMD per MIL-PRF-38534.

Part Numbering

