

RFFM6903

2.5V to 4.2V, ISM Band, 1W
915MHz Transmit/Receive Module

The RFFM6903 is a single-chip front end module (FEM) for applications in the 900MHz and 868MHz ISM Bands. The RFFM6903 addresses the need for aggressive size reduction for typical portable equipment RF front end design and greatly reduces the number of components outside of the core chipset thus minimizing the footprint and assembly cost of the overall solution. The RFFM6903 contains an integrated 1 Watt PA, SP3T antenna switch, integrated Tx harmonic filter, Tx thru path, LNA with bypass mode, and matching components. The RFFM6903 is packaged in a 28-pin, 6.0mm x 6.0mm x 0.975mm over-molded laminate package with backside ground which greatly minimizes next level board space and allows for simplified integration.



Package: LGA, 28-pin,
6.0mm x 6.0mm x 0.975mm

Features

- Integrated 50Ω Input/Output Match
- Tx Output Power: 30dBm
- Separate Tx/Rx 50 Ω transceiver interface
- Integrated PA, filtering LNA with Bypass Mode
- Transmit Thru path

Applications

- 868MHz/900MHz ISM Bands
- Single Chip RF Front End Module
- Wireless Automatic Metering
- Portable Battery Powered Equipment
- Smart Energy

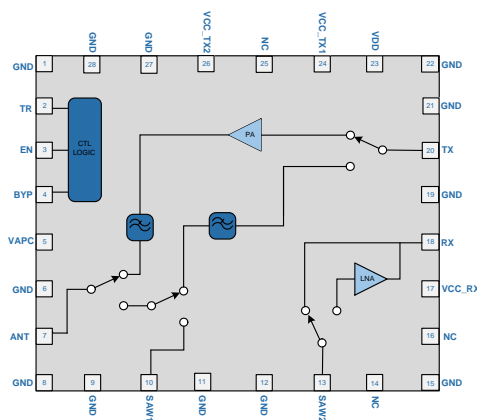

Functional Block Diagram

Ordering Information

RFFM6903SB	Standard 5-piece sample bag
RFFM6903SQ	Standard 25-piece sample bag
RFFM6903SR	Standard 100-piece reel
RFFM6903TR13	Standard 2500-piece reel
RFFM6903PCK-410	Fully assembled evaluation board w/ 5 piece bag

Absolute Maximum Ratings

Parameter	Rating	Unit
Voltage	5.25	V
Storage Temperature Range	-40 to +150	°C
Operating Temperature Range	-40 to +85	°C
Receive RF Input Power (SAW2)	+5	dBm
Transmit RF Input Power (PA Enabled)	+15	dBm
Transmit RF Input Power (PA Bypass)	+20	dBm
Receive RF Input Power (ANT)	+33	dBm
T/R Port Load VSWR in Transmit Mode	10:1	
ESD, HBM	350	V
ESD, CDM	300	V
Moisture Sensitivity Level	MSL3	



Caution! ESD sensitive device.



RFMD Green: RoHS status based on EU Directive 2011/65/EU (at time of this document revision), halogen free per IEC 61249-2-21, < 1000ppm each of antimony trioxide in polymeric materials and red phosphorus as a flame retardant, and <2% antimony in solder.

Exceeding any one or a combination of the Absolute Maximum Rating conditions may cause permanent damage to the device. Extended application of Absolute Maximum Rating conditions to the device may reduce device reliability. Specified typical performance or functional operation of the device under Absolute Maximum Rating conditions is not implied.

Nominal Operating Parameters

Parameter	Specification			Unit	Condition
	Min	Typ	Max		
Frequency*	890	925	960	MHz	
RF Port Impedance		50		Ω	
Operating Voltage	2.5	3.6	4.2	V	
Leakage Current					$V_{CC\text{Tx}1} = 3.6\text{V}$, $V_{CC\text{Tx}2} = 3.6\text{V}$, $V_{DD} = 3.6\text{V}$, $V_{CC\text{Rx}} = 3.6\text{V}$, $V_{APC} = 0.0\text{V}$, $EN = 0.0\text{V}$, $TR = 0.0\text{V}$, $BYP = 0.0\text{V}$, $RF = \text{Off}$, $\text{Temperature} = 25^\circ\text{C}$
V_{DD}		0.05	1.0	μA	
$V_{CC\text{ TX}}$		0.05	1.0	μA	
$V_{CC\text{ RX}}$		0.05	1.0	μA	
Operating Voltages					
$V_{CC\text{ TX}1/2}$	2.5	3.6	4.2	V	
$V_{CC\text{ RX}}$	2.5	3.3	4.2	V	
V_{DD}	2.5	3.6	4.2	V	
Tx Output Power Control (V_{APC})	0.00	2.25	2.50	V	V_{APC} operates such that the transmitter output power is saturated at a level lower than 1.9V and minimal variation in output power of the device occurs above that level

Parameter	Specification			Unit	Condition
	Min	Typ	Max		
Transmit High Power Mode					V_{CC}Tx1 = 3.6V, V_{CC}Tx2 = 3.6V, V_{DD} = 3.6V, V_{CC}Rx = 0.0V, V_{APC} = 2.25V, EN = 1.8V, T_R = 1.8V, BYP = 0.2V, Measured Path = TX to ANT, Temperature = 25°C
Output Power	30.0	30.5		dBm	V _{CC} Tx1, V _{CC} Tx2 = 3.6V, P _{IN} = +10dBm
	28				V _{CC} Tx1, V _{CC} Tx2 = 2.7V, P _{IN} = +10dBm
Thermal Resistance		24.73		C°/W	3.6V V _{CC} , 100% Duty, 30.2 dBm P _{OUT} , T _{REF} = 85° C
Input Return Loss	12.5			dB	
Output Return Loss	7			dB	
Operating Current		840	900	mA	P _{OUT} = 30.5dBm, ICC TX1 + ICC TX2
Quiescent Current (I _{CC} _TX1/2)		100	180	mA	I _{CC} TX1 + I _{CC} TX2, RF = Off
Quiescent Current (I _{DD})		7		mA	
Quiescent Current (I _{CC} _RX)		11.5		µA	
I _{DD}		12	18	mA	P _{OUT} = 30.5dBm
Second Harmonic			-60	dBc	
Third - Tenth Harmonic			-60	dBc	
Gain	20			dB	V _{CC} Tx1, V _{CC} Tx2 = 3.6V, P _{IN} = +10dBm
	18			dB	V _{CC} Tx1, V _{CC} Tx2 = 2.7V, P _{IN} = +10dBm
Transmit Bypass Mode					V_{CC}Tx1 = 3.6V, V_{CC}Tx2 = 3.6V, V_{DD} = 3.6V, V_{CC}Rx = 0.0V, V_{APC} = 0.0V, EN = 1.8V, T_R = 1.8V, BYP = 1.8V, Measured Path = TX to ANT, Temperature = 25°C
Insertion Loss		2.0	2.7	dB	P _{IN} = +5dBm
Input P1dB	27	28		dBm	
Input IP3		41		dBm	
Input Return Loss	18			dB	
Output Return Loss	13.5			dB	
Second Harmonic Attenuation			-46	dB	P _{IN} = +12dBm, Second Harmonic Insertion Loss
Third - Tenth Harmonic Attenuation			-47	dB	P _{IN} = +12dBm, Third - Tenth Harmonic Insertion Loss
Receive Mode					V_{CC}Tx1 = 3.3V, V_{CC}Tx2 = 3.3V, V_{DD} = 3.3V, V_{CC}Rx = 3.3V, V_{APC} = 0.0V, EN = 1.8V, T_R = 0.2V, BYP = 0.2V, Measured Path = SAW2 to RX, Temperature = 25°C
IP1dB		-2.5		dBm	
Gain	13.5	15.5	16.0	dB	P _{IN} = -20dBm
Current	4	5	6	mA	
I _{DD}		150		µA	
Noise Figure		1.7	2.0	dB	
IIP3	1.4	3.0		dBm	
Input Return Loss	18			dB	
Output Return Loss	10			dB	

Parameter	Specification			Unit	Condition
	Min	Typ	Max		
Receive Bypass Mode					$V_{CC}Tx1 = 3.3V$, $V_{CC}Tx2 = 3.3V$, $V_{DD} = 3.3V$, $V_{CC}Rx = 3.3V$, $V_{APC} = 0.0V$, $EN = 1.8V$, $T_R = 0.2V$, $BYP = 1.8V$, Measured Path = SAW2 to RX, Temperature = 25°C
Insertion Loss	1.6	2.2	2.4	dB	
Current ($I_{CC_TX1/2}$)		90		μA	
(I_{DD})		100		μA	
(I_{CC_RX})		50		nA	
IP1dB		17.5		dBm	
IIP3		42		dBm	
Input Return Loss	11			dB	
Output Return Loss	14			dB	
Antenna Switch					Measured ANT to SAW1, RX & RX BYPASS Modes
Insertion Loss		0.5		dB	
Input Return Loss	9	10		dB	
Output Return Loss	9	10		dB	
Isolation					
Isolation	24			dB	ANT to SAW1 (Module in TX BYP Mode)
	44			dB	ANT to SAW1 (Module in TX Mode)
Logic					
Control Logic HIGH	1.6		4.0	V	Max Control Logic High = $V_{DD} - 0.2V_{DC}$
Control Logic LOW		0.2	0.3	V	
Control Logic HIGH Current		0.1		μA	
Control Logic LOW Current		0.1		μA	
VAPC High Current		50		μA	Across all rated voltages at rated power

*868MHz data available upon request

Table

Operating Mode	TR	EN	BYP	PA	LNA
	(Pin2)	(Pin3)	(Pin4)		
Transmit	High	High	Low	ON	OFF
Transmit Bypass	High	High	High	OFF	OFF
Receive	Low	High	Low	OFF	ON
Receive Bypass	Low	High	High	OFF	OFF
Shutdown	X	Low	X	OFF	OFF

Typical Performance

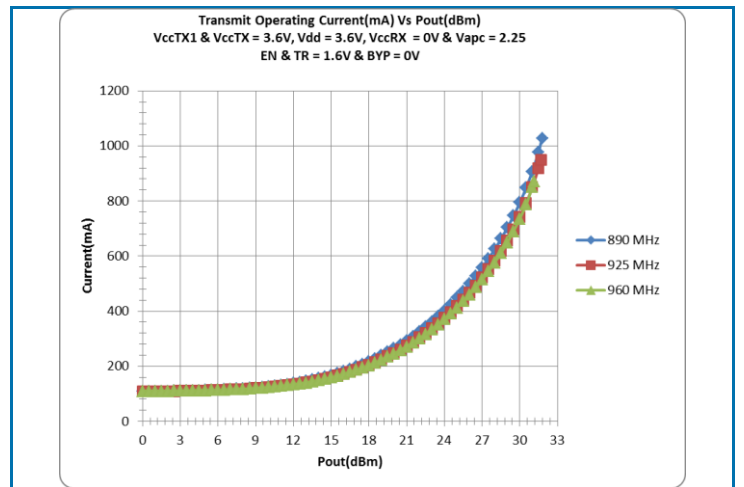
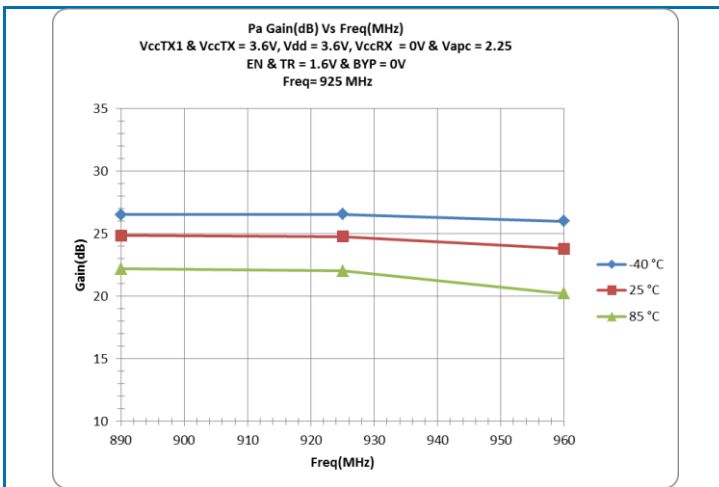
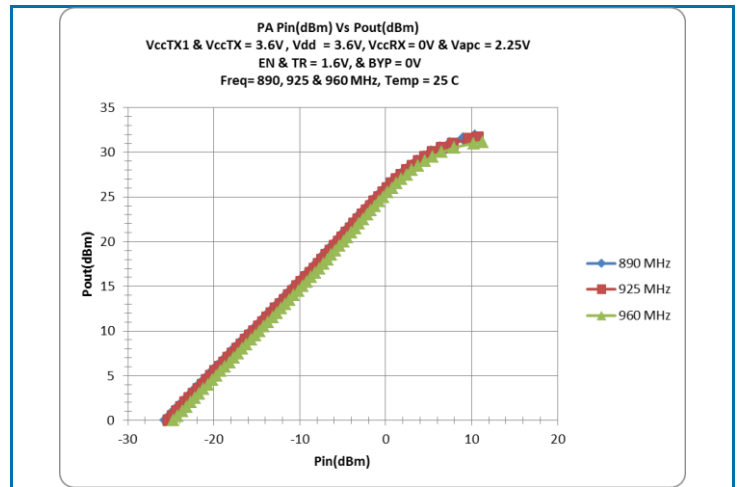
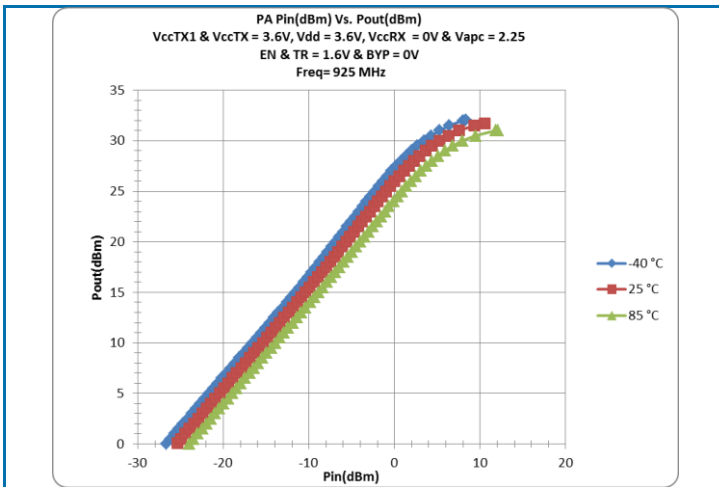
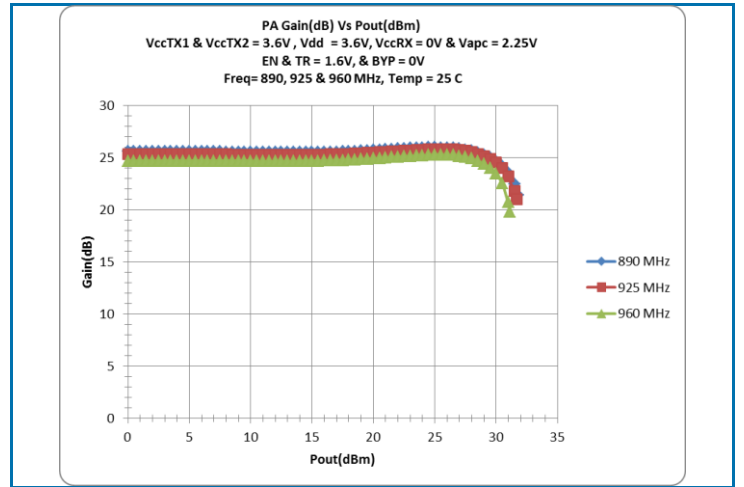
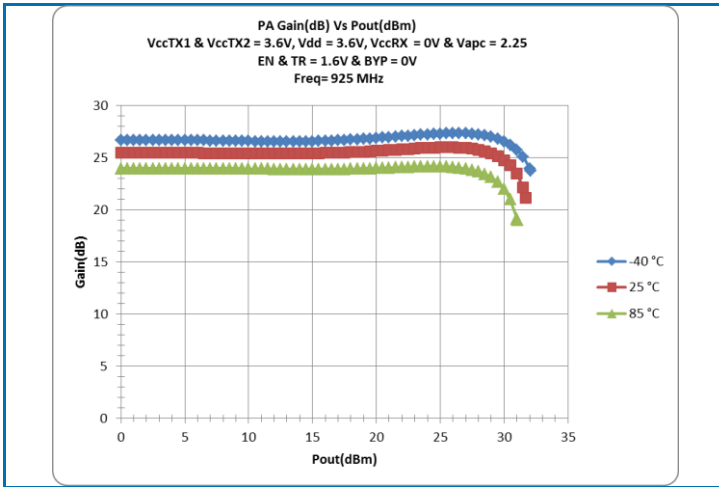

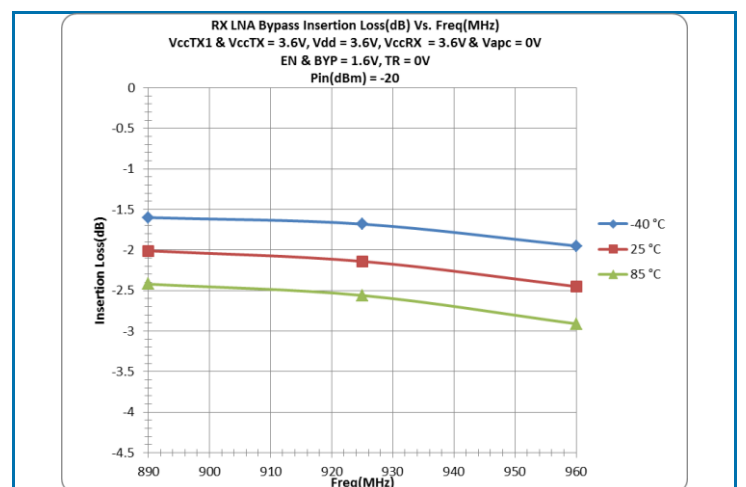
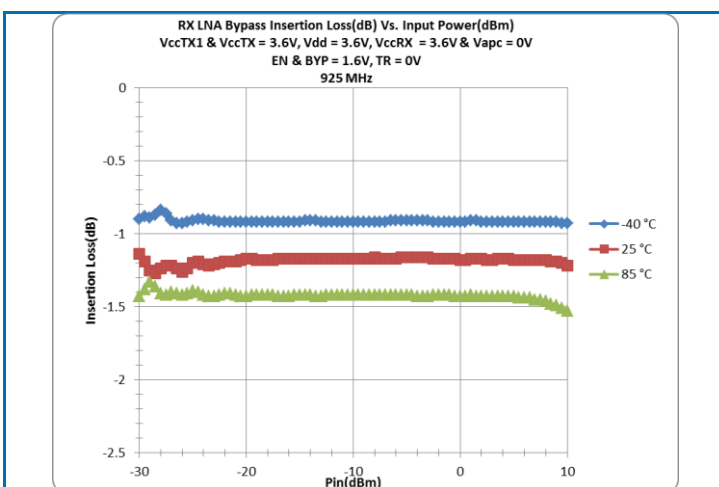
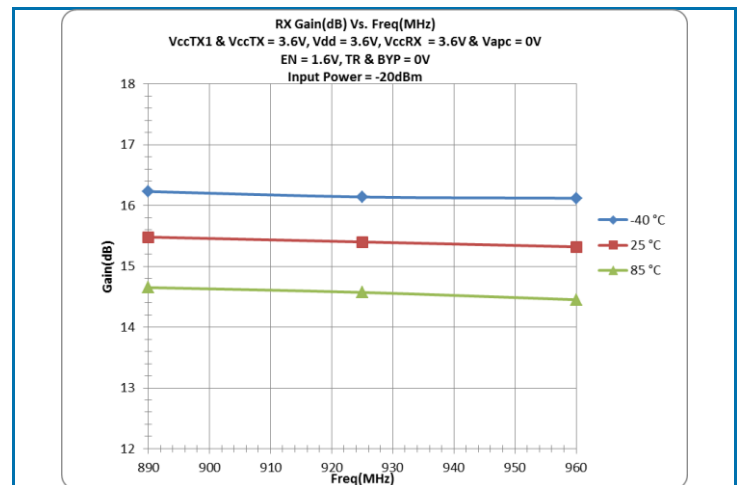
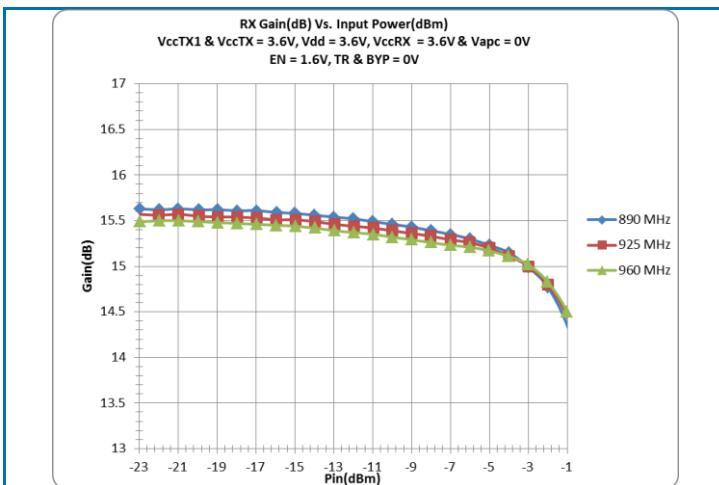
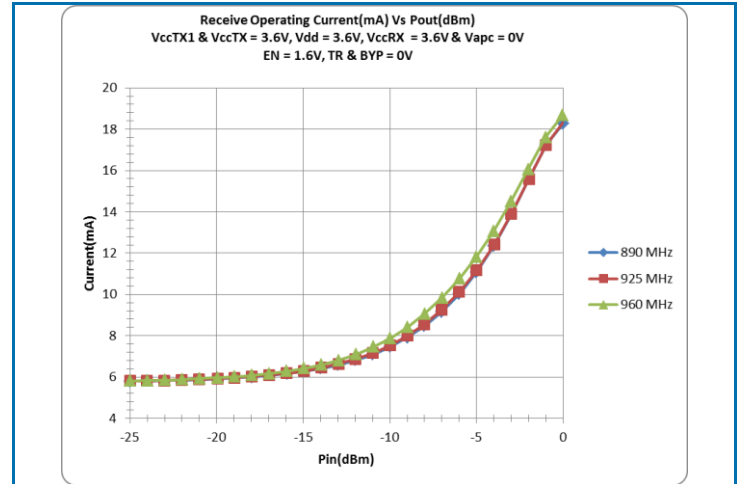
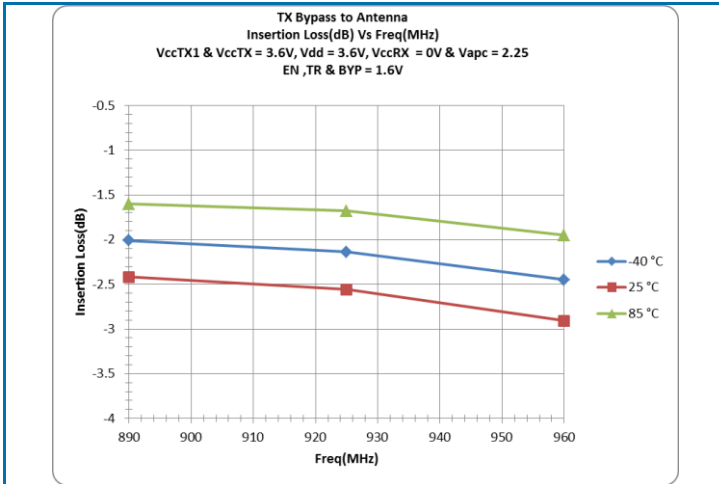

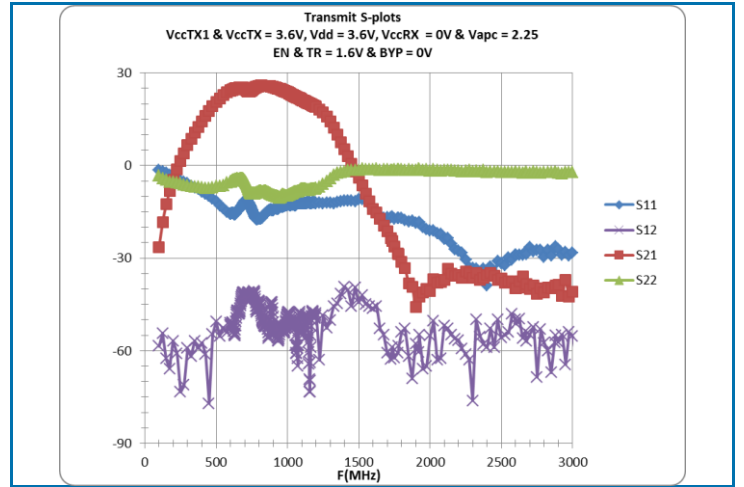
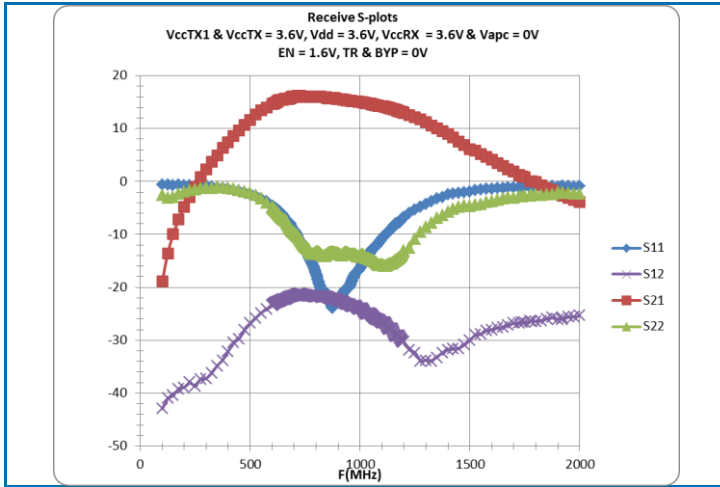

Application Schematic

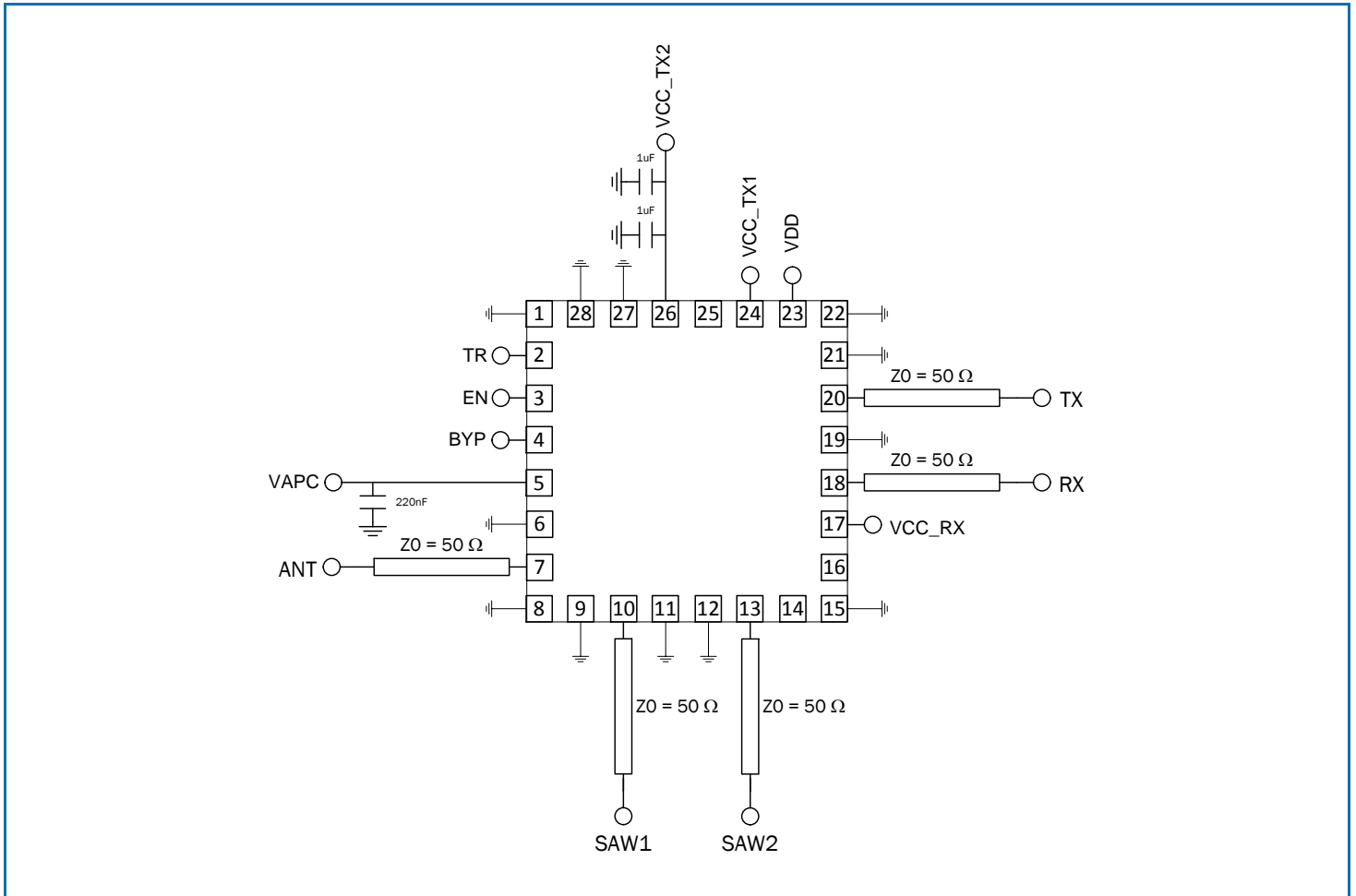

Pin Out

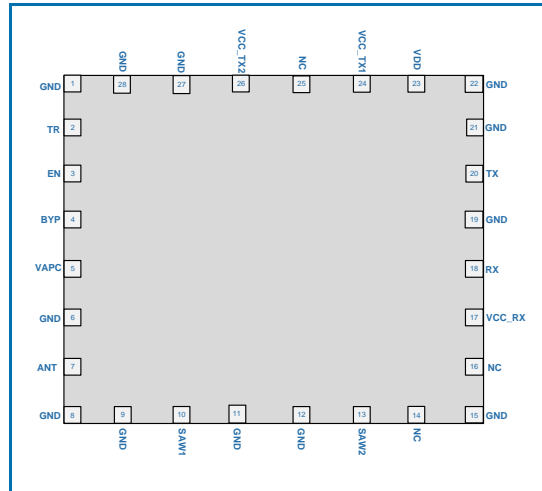

Package Drawing

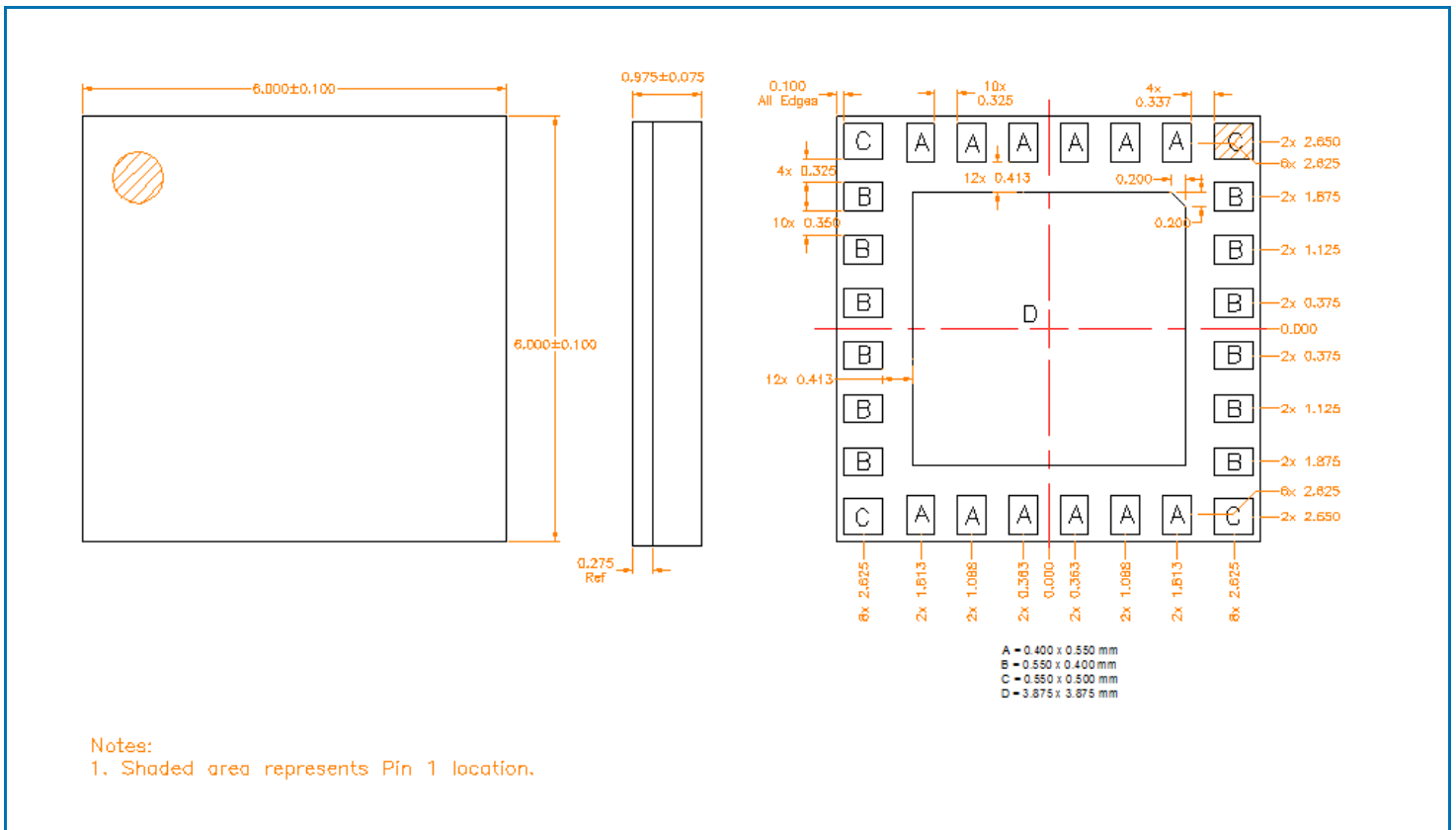

PCB Patterns

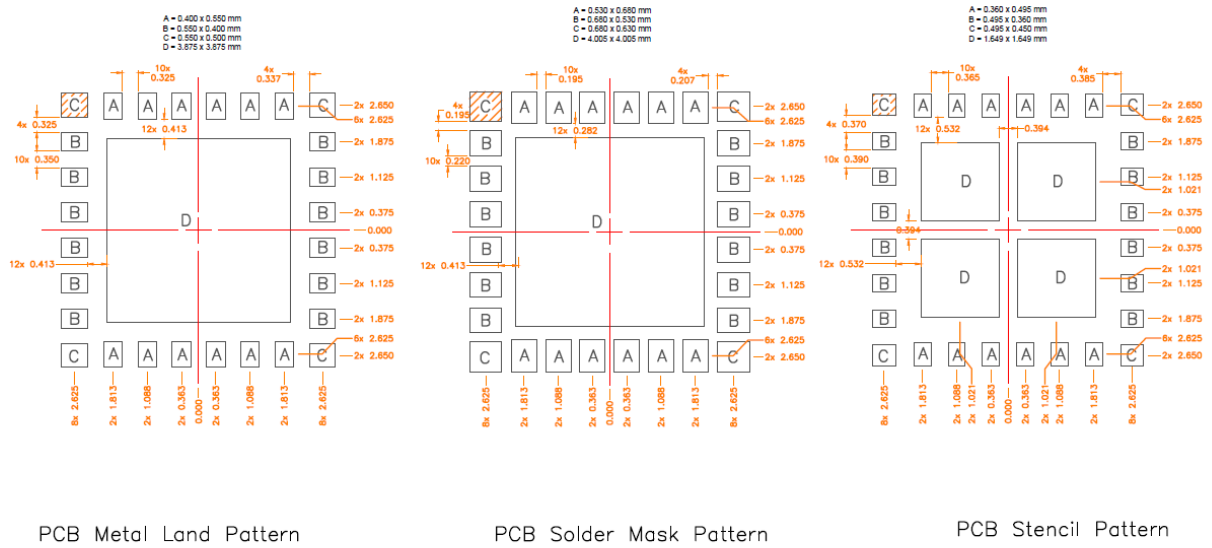

Notes:
 1. Shaded area represents Pin 1 location.

Pin Names and Descriptions

Pin	Name	Description
1	GND	Ground
2	TR	Digital Input: Transmit/Receive
3	EN	Digital Input: Shutdown Mode
4	BYP	Digital Input: RX Bypass Control
5	VAPC	Analog Input
6	GND	Ground
7	ANT	Antenna Switch Common Port, internally matched to 50Ω, DC blocked
8	GND	Ground
9	GND	Ground
10	SAW1	Receive side of antenna switch, internally matched to 50Ω, DC blocked
11	GND	Ground
12	GND	Ground
13	SAW2	RX and RX bypass input port, internally matched to 50Ω, DC blocked
14	NC	Not internally connected/open
15	GND	Ground
16	NC	Not internally connected/open
17	VCC_RX	3.3V power supply
18	RX	Receive output, internally matched to 50Ω, DC blocked
19	GND	Ground
20	TX	TX and TX bypass input port, internally matched to 50Ω, DC blocked
21	GND	Ground
22	GND	Ground
23	VDD	3.6V power supply
24	VCC_TX1	3.6V power supply
25	NC	Not internally connected/open
26	VCC_TX2	3.6V power supply
27	GND	Ground
28	GND	Ground