

RoHS compliant

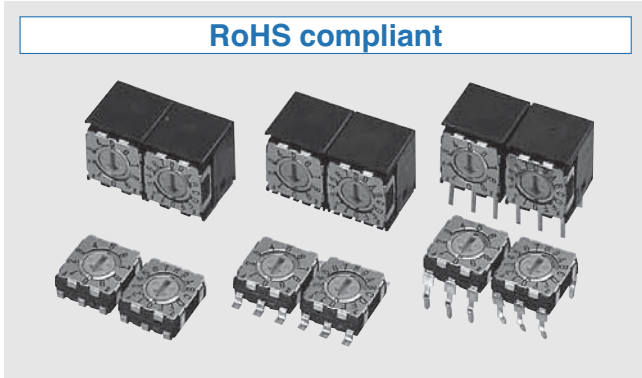

FEATURES

- RoHS compliant
- Low profile of 2.9 mm
- Wide variety (top or side setting, 6, 10 or 16 positions, J-hook, gull wing or through hole pins) to choose from
- Compatible with flow (top setting only) / reflow soldering
- Washable

INTERNAL STRUCTURE

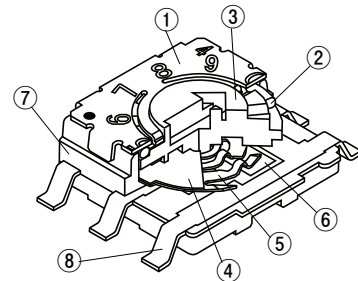

Part name	Material	Flammability
① Cover	Stainless steel (SUS 304)	—
② “O” ring	Silicone rubber	UL94HB
③ Rotor	Polyphenylenesulphide	UL94V-0
④ Spacer	Stainless steel (SUS 304)	—
⑤ Moving contact	Copper alloy, Gold-plated	
⑥ Fixed contact		
⑦ Housing	Epoxy	UL94V-0
⑧ Terminal pin	Copper alloy, Gold-plated	—

PART NUMBER DESIGNATION

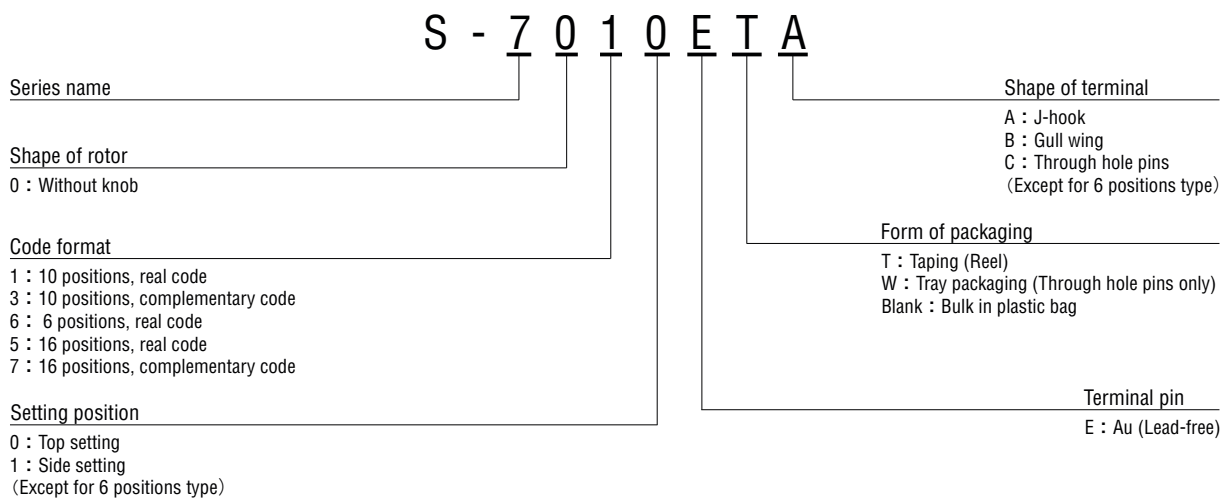

※ Please refer to the LIST OF PART NUMBERS when placing orders.

S-7000

ROTARY CODED SWITCHES (SMD)

CODE FORMAT

No. of positions		16 positions															
		10 positions															
Position		6 positions															
		0	1	2	3	4	5	6	7	8	9	A	B	C	D	E	F
Code	Real code	8								●	●	●	●	●	●	●	
		4				●	●	●	●				●	●	●	●	
		2			●	●			●	●			●	●		●	●
		1		●		●			●		●		●		●		●
	Complementary code	8	●	●	●	●	●	●	●								
		4	●	●	●	●				●	●	●	●				
		2	●	●			●	●			●	●		●	●		
		1	●		●		●		●		●		●		●		

● ... Contact closed

LIST OF PART NUMBERS

Setting position	Shape of terminal	Form of packaging	Binary coded hexal	Binary coded decimal		Binary coded hexadecimal		Pieces in package	
			Real code	Real code	Complementary code	Real code	Complementary code		
Top setting	A (J-hook)	Taping	S-7060ETA	S-7010ETA	S-7030ETA	S-7050ETA	S-7070ETA	500 pcs. / reel	
		Plastic bag	S-7060EA	S-7010EA	S-7030EA	S-7050EA	S-7070EA	50 pcs. / pack	
	B (Gull wing)	Taping	S-7060ETB	S-7010ETB	S-7030ETB	S-7050ETB	S-7070ETB	500 pcs. / reel	
		Plastic bag	S-7060EB	S-7010EB	S-7030EB	S-7050EB	S-7070EB	50 pcs. / pack	
	C (Through hole pin)	Tray packaging			S-7010EWC	S-7030EWC	S-7050EWC	S-7070EWC	50 pcs. / tray
		Plastic bag			S-7010EC	S-7030EC	S-7050EC	S-7070EC	50 pcs. / pack
Side setting	A (J-hook)	Taping		↻ S-7011ETA	↻ S-7031ETA	↻ S-7051ETA	↻ S-7071ETA	500 pcs. / reel	
		Plastic bag		↻ S-7011EA	↻ S-7031EA	↻ S-7051EA	↻ S-7071EA	50 pcs. / pack	
	B (Gull wing)	Taping		↻ S-7011ETB	↻ S-7031ETB	↻ S-7051ETB	↻ S-7071ETB	500 pcs. / reel	
		Plastic bag		↻ S-7011EB	↻ S-7031EB	↻ S-7051EB	↻ S-7071EB	50 pcs. / pack	
	C (Through hole pin)	Tray packaging		↻ S-7011EWC	↻ S-7031EWC	↻ S-7051EWC	↻ S-7071EWC	50 pcs. / tray	
		Plastic bag		↻ S-7011EC	↻ S-7031EC	↻ S-7051EC	↻ S-7071EC	50 pcs. / pack	

☐ : Not manufactured

※ Verify the above part numbers when placing orders.

Taping and tray version can be supplied only in reel or tray unit.

The products indicated by ↻ mark are manufactured upon receipt of order basis.

S-7000

ROTARY CODED SWITCHES (SMD)

STANDARD SPECIFICATIONS

Circuit type	BCD (Real code, complementary code) BCH (Real code, complementary code)
Operating temperature range	-40 ~ 85 °C
Storage temperature range	
Sealing	Washable by "O" ring ※Please refer to page 150,151
Net weight	Approx. 0.26 g (A or B type in top setting) Approx. 0.28 g (C type in top setting) Approx. 0.62 g (Side setting type)

ELECTRICAL CHARACTERISTICS

Contact rating	DC50 V 100 mA DC5 V 100 mA DC20 mV 1 μA
Non-switching	
Minimum	
Contact resistance	100 mΩ maximum
Insulation resistance	100 MΩ (DC100 V) minimum
Dielectric strength	AC250 V, 60 s

MECHANICAL CHARACTERISTICS

No. of positions	6, 10, 16
Adjustment torque	20 mN·m {204 gf·cm} maximum
Stepping angle	60° (6 positions) 36° (10 positions) 22.5° (16 positions)
Solderability	245 ± 3 °C, 2 ~ 3 s
Soldering heat	Reflow : 255 °C (Peak temperature) (Please refer to the profile below) Flow : 260 ± 3 °C, 5 ~ 6 s, two times maximum Manual soldering : 350 ± 10 °C, 3 ~ 4 s
Shear (adhesion)	5 N {0.51 kgf}, 10 s
Substrate bending	Width 90 mm, bend 3 mm, 5 s, 1 time
Pull-off strength	5 N {0.51 kgf}, 10 s

{ } : Reference only

ENVIRONMENTAL CHARACTERISTICS

Vibration	(Amplitude) 1.5 mm or (Acceleration) 98 m/s ² , 10-500-10 Hz, 3 directions for 2 h each
Shock	490 m/s ² , 11 ms 6 directions for 3 times each
Load life	10000 steps minimum, DC5 V, 100 mA
Humidity (Steady state)	40 °C, Relative humidity 90 ~ 95 %, 240 h
High temperature exposure	85 °C, 96 h
Low temperature exposure	-40 °C, 96 h
Thermal shock	-40 (0.5 h) ~ 85 °C (0.5 h), 5 cycles

<Reflow profile for soldering heat evaluation>

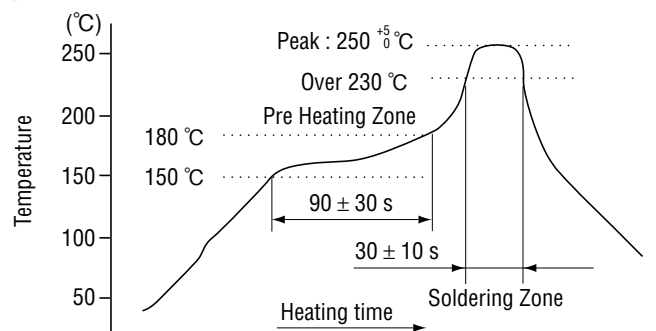

Reflow : two times maximum

S-7000

ROTARY CODED SWITCHES (SMD)

OUTLINE DIMENSIONS

- S-7010EA (Real code)
- S-7030EA (Complementary code)

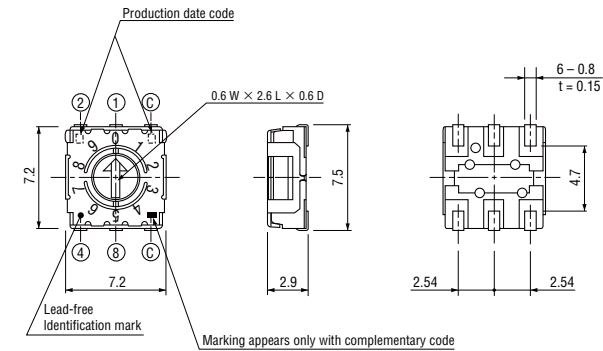

- S-7050EA (Real code)
- S-7070EA (Complementary code)

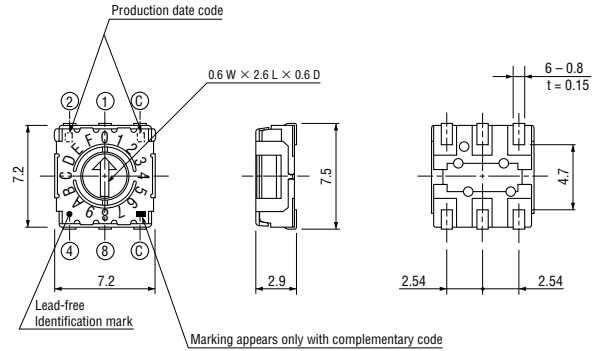

Unless otherwise specified, tolerance: ± 0.3 (Unit: mm)

- S-7010EB (Real code)
- S-7030EB (Complementary code)

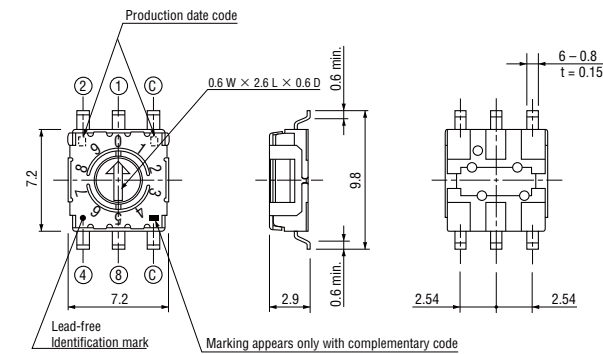

- S-7050EB (Real code)
- S-7070EB (Complementary code)

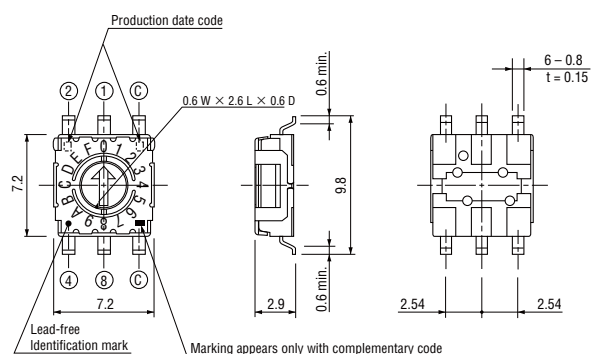

- S-7010EC (Real code)
- S-7030EC (Complementary code)

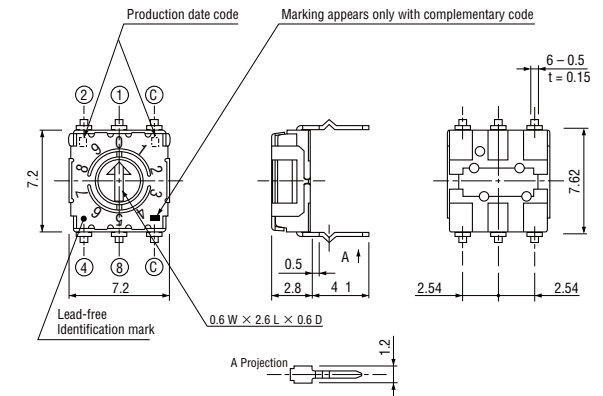

- S-7050EC (Real code)
- S-7070EC (Complementary code)

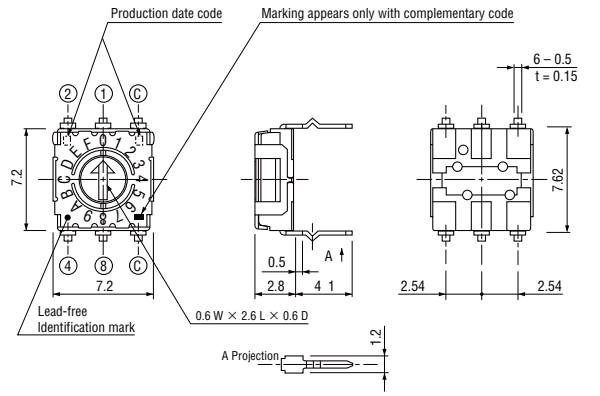

S-7000

ROTARY CODED SWITCHES (SMD)

OUTLINE DIMENSIONS

- S-7011EA (Real code)
- S-7031EA (Complementary code)

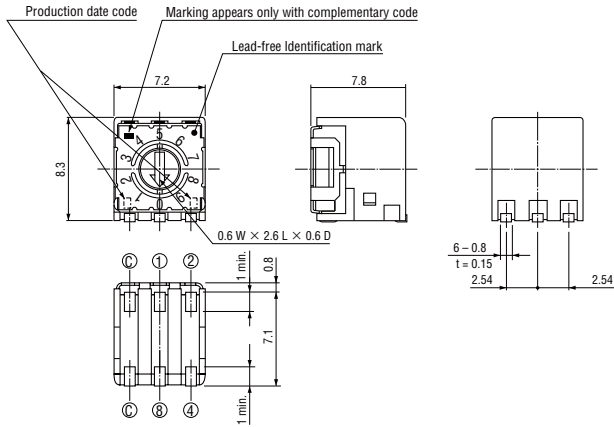

Unless otherwise specified, tolerance: ± 0.3 (Unit: mm)

- S-7051EA (Real code)
- S-7071EA (Complementary code)

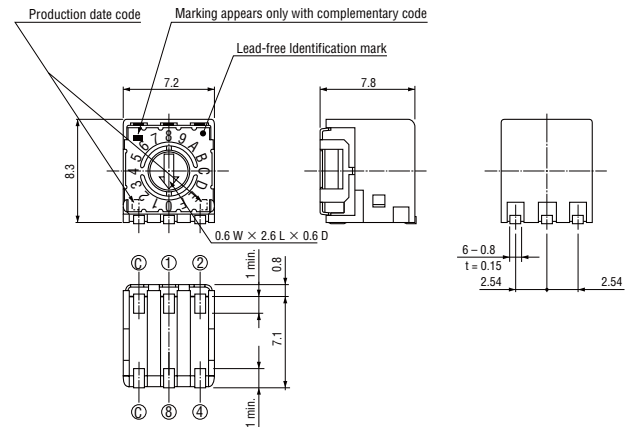

- S-7011EB (Real code)
- S-7031EB (Complementary code)

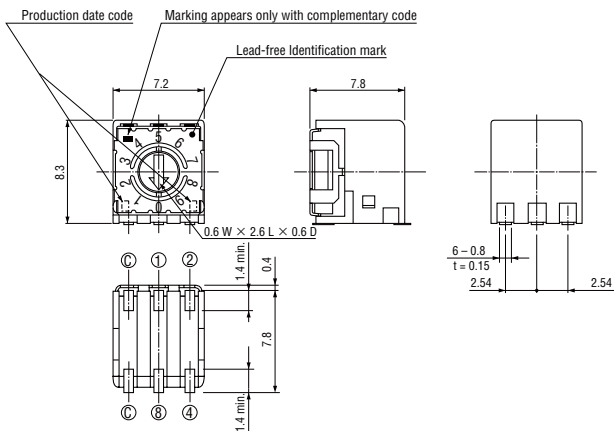

- S-7051EB (Real code)
- S-7071EB (Complementary code)

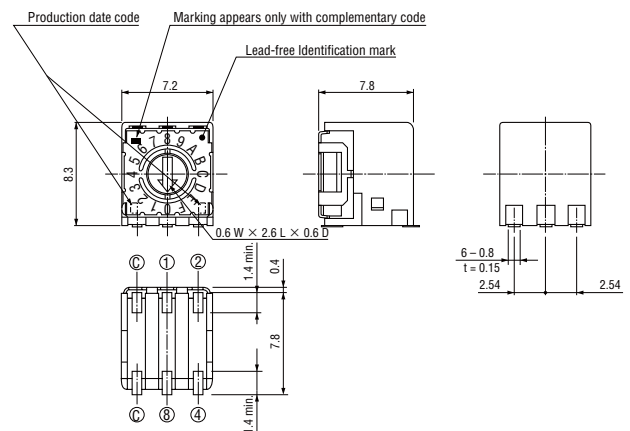

- S-7011EC (Real code)
- S-7031EC (Complementary code)

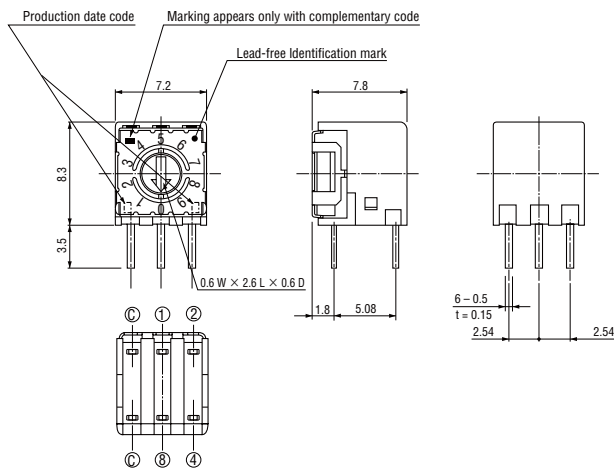

- S-7051EC (Real code)
- S-7071EC (Complementary code)

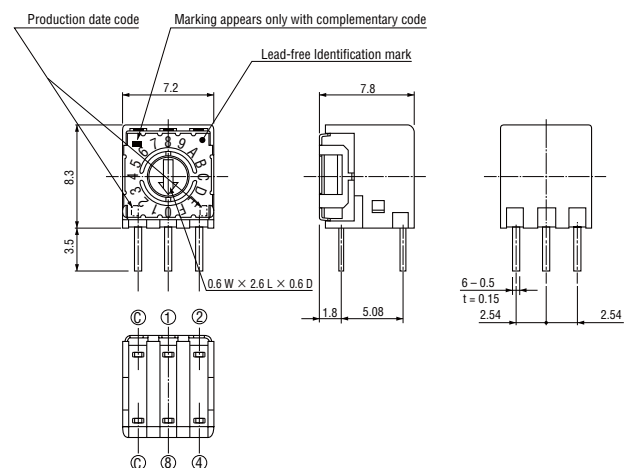

S-7000

ROTARY CODED SWITCHES (SMD)

OUTLINE DIMENSIONS

S-7060EA (Real code)

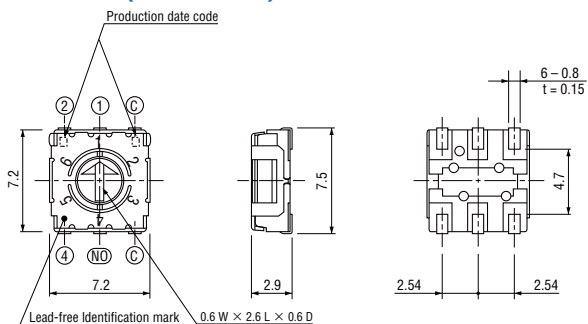

Unless otherwise specified, tolerance: ± 0.3 (Unit: mm)

S-7060EB (Real code)

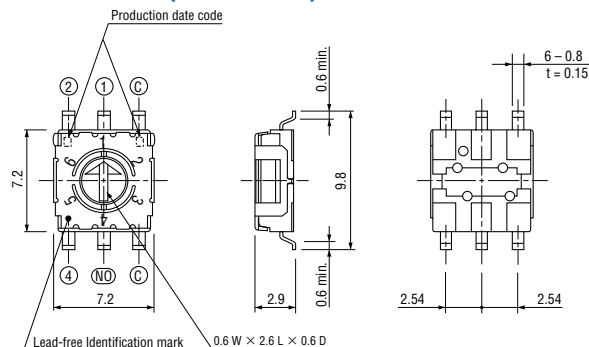

RECOMMENDED P.C.B. PAD OUTLINE DIMENSIONS

<Top setting>

A type

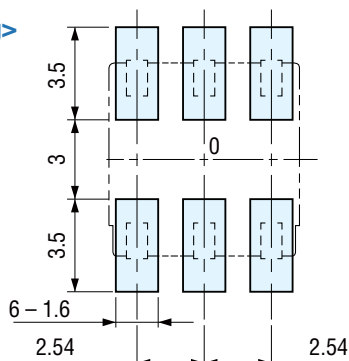

B type

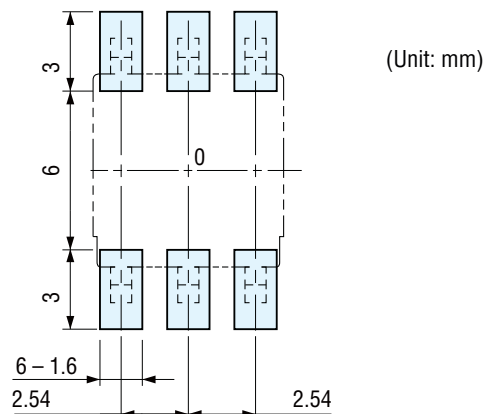

<Side setting>

A type

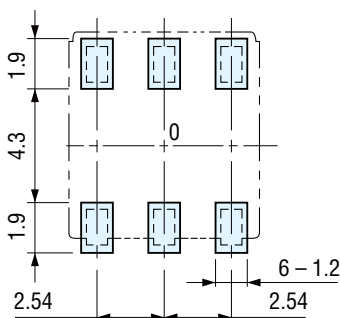

B type

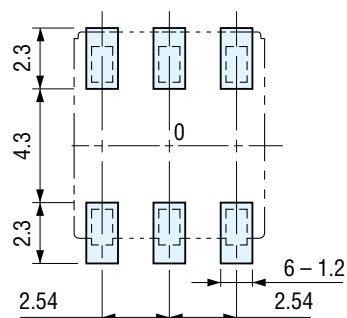

SIZE OF P.C.B. PROCESSING

<Top setting>

C type

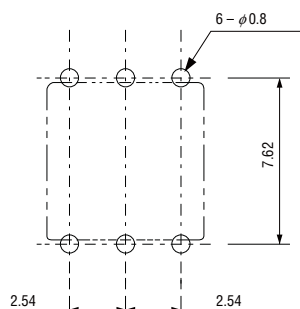

<Side setting>

C type

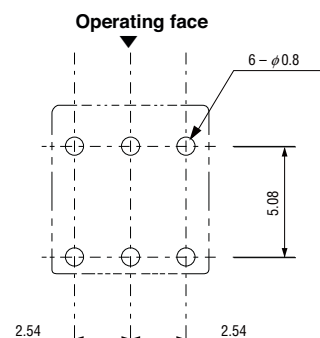

S-7000

ROTARY CODED SWITCHES (SMD)

PACKAGING SPECIFICATIONS

<Taping packaging specifications>

- Taping version is packaged in 500 pcs. per reel.
Orders will be accepted for units of 500 pcs., i.e., 500, 1000, 1500, pcs., etc.
- Taping version is boxed with one reel (500 pcs.).

Maximum number of consecutive missing pieces = 2
Leader length and reel dimension are shown in the diagrams below:

● Reel dimensions

(Unit: mm)

(Conforms to JIS C 0806-3)

(In accordance with EIAJ ET-7200A)

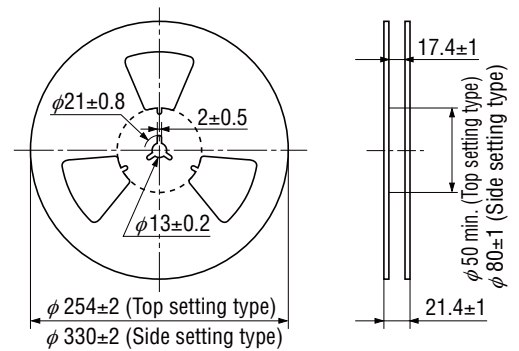
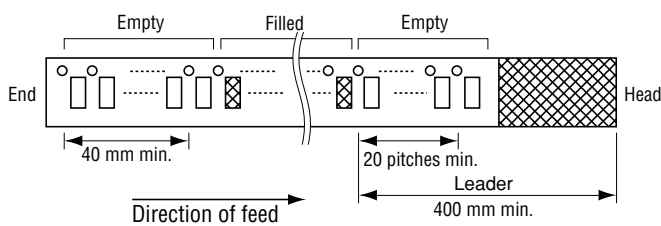

S-7000

ROTARY CODED SWITCHES (SMD)

(Conforms to JIS C 0806-3)

● S-70□□ETA <Top setting>

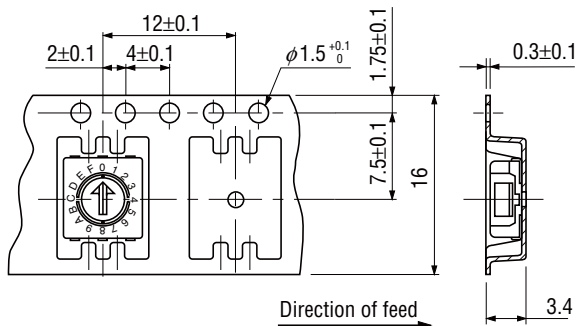

<Side setting>

(Unit: mm)

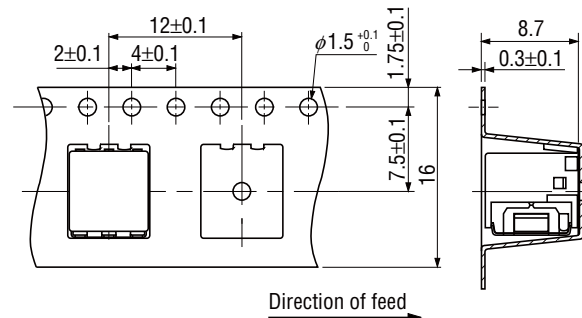

● S-70□□ETB <Top setting>

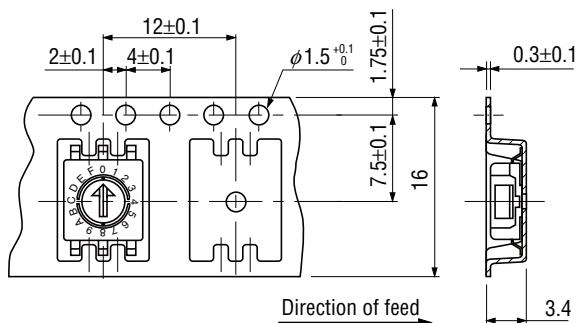

<Side setting>

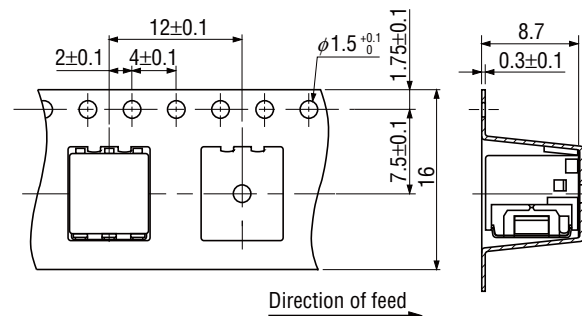

<Tray packaging specifications>

- Tray version is packaged in 50 pcs. per tray. Orders will be accepted for units of 50 pcs., i. e., 50, 100, 150 pcs. etc.
- Tray version is boxed with 10 trays.

<Bulk pack specifications>

- The smallest unit of bulk pack in a plastic bag is 10 pcs. per pack. Orders will be accepted for unit of minimum 10 pcs., i.e., 10, 20, 30 pcs., etc.
- Boxing of bulk in a plastic bag (top setting type) is performed with 50 pcs. (standard 200 pcs.) per box. Only that side setting type is 100 pcs. (standard 200 pcs.) per box.