



**DESCRIPTION: 6W Wide Voltage Input DC/DC Converters**

The rated output power of TP06DB converters is 6W, the outline dimensions is "25.4\*25.4\*11.2", 2:1 and 4:1 wide input voltage range, the voltage range is 9V-18V, 18V-36V, 36V-72V, 9V-36V and 18V-72VDC. The accuracy of the converter can reach ±1%, it can be widely used in telecommunications, railway transportation, instrument and etc.

**FEATURES**

6W output power	2:1 and 4:1 wide input voltage range	Over load protection
25.4mm*25.4mm*11.2mm standard package	Fixed switching frequency	Over voltage protection
Metal shell package	RoHS compliant	Operating temperature: -25℃ to 55℃

**SELECTION GUIDE**

Part Number	Input Voltage		Output		Efficiency(Typ) %	Maximum Capacitive Load (u F)
	voltage (VDC)		Voltage (VDC)	Current (A)		
	Rated	Range values				
TP06DB12S03	12(2:1)	9-18	3.3	2	≥73	2200
TP06DB12S05	12(2:1)	9-18	5	1.2	≥74	1500
TP06DB12S12	12(2:1)	9-18	12	0.5	≥75	660
TP06DB12S15	12(2:1)	9-18	15	0.4	≥75	470
TP06DB12D05	12(2:1)	9-18	±5	±0.6	≥76	±850
TP06DB12D12	12(2:1)	9-18	±12	±0.25	≥78	±140
TP06DB12D15	12(2:1)	9-18	±15	±0.2	≥79	±47
TP06DB24S03	24(2:1)	18-36	3.3	2	≥74	2200
TP06DB24S05	24(2:1)	18-36	5	1.2	≥76	1500
TP06DB24S12	24(2:1)	18-36	12	0.5	≥76	660
TP06DB24S15	24(2:1)	18-36	15	0.4	≥76	470
TP06DB24D05	24(2:1)	18-36	±5	±0.6	≥78	±850
TP06DB24D12	24(2:1)	18-36	±12	±0.25	≥79	±140
TP06DB24D15	24(2:1)	18-36	±15	±0.2	≥79	±47
TP06DB48S03	48(2:1)	36-72	3.3	2	≥74	2200
TP06DB48S05	48(2:1)	36-72	5	1.2	≥76	1500
TP06DB48S12	48(2:1)	36-72	12	0.5	≥78	660
TP06DB48S15	48(2:1)	36-72	15	0.4	≥78	470
TP06DB48D05	48(2:1)	36-72	±5	±0.6	≥79	±850
TP06DB48D12	48(2:1)	36-72	±12	±0.25	≥79	±140
TP06DB48D15	48(2:1)	36-72	±15	±0.2	≥80	±47
TP06DB24S05W	24(4:1)	9-36	5	1.2	≥75	1500
TP06DB24S12W	24(4:1)	9-36	12	0.5	≥75	660
TP06DB24S15W	24(4:1)	9-36	15	0.4	≥75	470
TP06DB24D05W	24(4:1)	9-36	±5	±0.6	≥77	±850
TP06DB24D12W	24(4:1)	9-36	±12	±0.25	≥78	±140
TP06DB24D15W	24(4:1)	9-36	±15	±0.2	≥78	±47
TP06DB48S05W	48(4:1)	18-72	5	1.2	≥75	1500
TP06DB48S12W	48(4:1)	18-72	12	0.5	≥77	660
TP06DB48S15W	48(4:1)	18-72	15	0.4	≥77	470
TP06DB48D05W	48(4:1)	18-72	±5	±0.6	≥78	±850
TP06DB48D12W	48(4:1)	18-72	±12	±0.25	≥78	±140
TP06DB48D15W	48(4:1)	18-72	±15	±0.2	≥79	±47

All specifications typical at TA=25°C, nominal input voltage and rated output current unless otherwise specified

GENERAL CHARACTERISTICS					
parameter	Test conditions	Min	Typ	Max	Units
Isolation voltage	Input to Output		500	1500	VDC
Isolation resistance	Input to Output	100M			ohm
Seismic	10-55Hz		5		G
MTBF	MIL-HDBK-217F2		5 x 10 <sup>5</sup>		hrs
Over-current protection mode	Full input range		Auto recovery		
Cooling	Free air convection				
Case material	Metal case				

INPUT CHARACTERISTICS					
parameter	Test conditions	Min	Typ	Max	Units
Startup voltage	12V Input module(9V -18V)	8.8	9	9.3	VDC
Startup voltage	24V Input module(18V-36V)			18	VDC
Startup voltage	48V Input module(36V-72V )			36	VDC
Startup voltage	24V Input module(9V -36V)	8.8	9	9.3	VDC
Startup voltage	48V Input module(18V-72V)			18	VDC
Start rising time	Input rising time from 5%-100%	20			ms

OUTPUT CHARACTERISTICS					
parameter	Test conditions	Min	Typ	Max	Units
Voltage accuracy	I <sub>o</sub> =0.1...1.0 x I <sub>onom</sub> V <sub>i</sub> =V <sub>i</sub> rated			±1	%
Line regulation	V <sub>imin</sub> ≤V <sub>i</sub> ≤V <sub>imax</sub>			±0.2	%
Load regulation	I <sub>o</sub> =0.1...1.0 x I <sub>onom</sub> V <sub>imin</sub> ≤ V <sub>i</sub> ≤V <sub>imax</sub>			±0.5	%
Auxiliary voltage accuracy	Main Load and auxiliary load differ 25%,the auxiliary circuit of the load with at least 25%, the main circuit with full load			±3	%
Ripple and noise	20MHz bandwidth			±1	%
Over-current protection	V <sub>imin</sub> ≤V <sub>i</sub> ≤V <sub>imax</sub>	120			%
Transient recovery time	25% load change			±5	%
Transient overshoot range	25% load change			400	us
Switch frequency	V <sub>imin</sub> ≤V <sub>i</sub> ≤V <sub>imax</sub>		300		KHz

ENVIRONMENT CHARACTERISTICS					
parameter	Test conditions	Min	Typ	Max	Units
Environment temperature	industrial-class	-25		+55	°C
Maximum case temperature	industrial-class			+85	°C
Storage temperature	Industry-class/ Military J1&J3 class	-40		+105	°C
Relative humidity	No condensation	5		90	RH(%)
Temperature coefficient			±0.02		%/°C

- Case temperature under shall not exceed the maximum case temperature level.

**MECHANICAL DIMENSIONS**

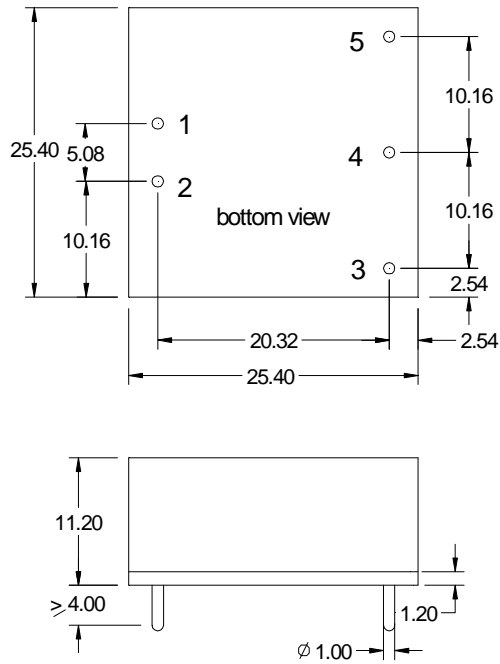

PIN CONNECTION		
Pin	Single output	Dual output
1	+Vin	+Vin
2	-Vin	-Vin
3	-Vout	-Vout
4	/	Com
5	+Vout	+Vout

Units: mm  
Tolerance: ±0.2mm

**MODEL SELECTION**

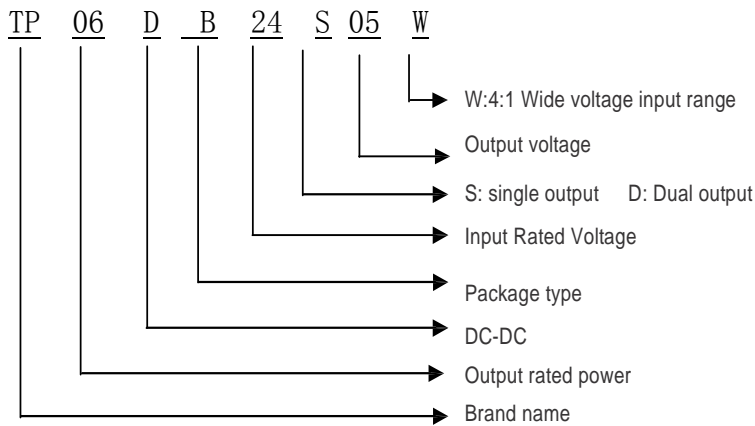

**RECOMMEND CIRCUIT:**

Single Output:

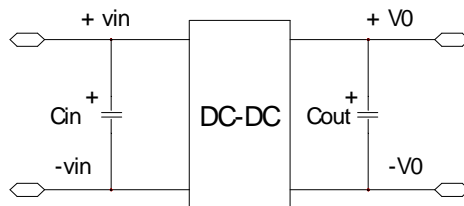

## RECOMMEND CIRCUIT:

Dual Output:

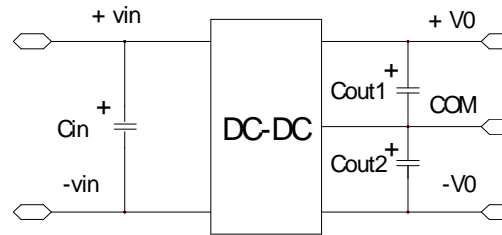

- Add input capacitance  $C_{in}$  is helpful to improve the electromagnetic compatibility, recommend  $C_{in}$  use 47  $\mu\text{F}$ -100 $\mu\text{F}$  of the electrolytic capacitors.
- If the module connect to the digital circuits, please add the  $C_{out}$ ,  $C_{out1}$ ,  $C_{out2}$ .
- If  $C_{out}$ ,  $C_{out1}$ ,  $C_{out2}$  value is too high or lower ESR, it will cause the module instable,
- The recommended value of  $C_{out}$ ,  $C_{out1}$ ,  $C_{out2}$  should be 100  $\mu\text{F}/\text{A}$ , the current here means the output current.

## USING ATTENTIONS

- Module will cause irreversible damage when in the state of the input reverse polarity.
- Module will cause irreversible damage when in the long-term overload conditions.
- Module will cause irreversible damage when out of the maximum input voltage range.