

PRELIMINARY DATA SHEET
Low Distortion GaAs Power FET

- **NON-HERMETIC 180MIL METAL FLANGE PACKAGE**
- **+34.0dBm TYPICAL OUTPUT POWER**
- **16.5dB TYPICAL POWER GAIN AT 2GHZ**
- **0.5 X 4800 MICRON RECESSED “MUSHROOM” GATE**
- **Si₃N₄ PASSIVATION**
- **ADVANCED EPITAXIAL HETEROJUNCTION PROFILE PROVIDES EXTRA HIGH POWER EFFICIENCY, AND HIGH RELIABILITY**

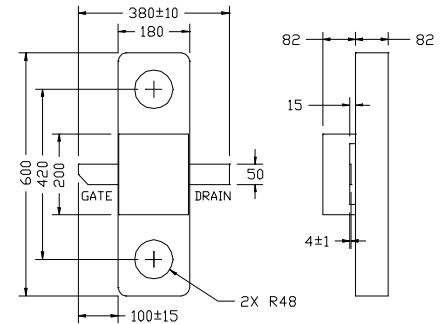

All Dimensions In Mils

ELECTRICAL CHARACTERISTICS (T_a = 25 °C)

SYMBOLS	PARAMETERS/TEST CONDITIONS	MIN	TYP	MAX	UNIT
P_{1dB}	Output Power at 1dB Compression V _{ds} =8V, I _{ds} =50% I _{dss}		f= 2GHz 34.0 f= 4GHz 34.0		dBm
G_{1dB}	Gain at 1dB Compression V _{ds} =8V, I _{ds} =50% I _{dss}		f= 2GHz 16.5 f= 4GHz 11.5		dB
PAE	Power Added Efficiency at 1dB Compression V _{ds} =8V, I _{ds} =50% I _{dss}		f=2GHz 40		%
I_{dss}	Saturated Drain Current V _{ds} =3V, V _{gs} =0V	800	1360	1760	mA
G_m	Transconductance V _{ds} =3V, V _{gs} =0V	560	720		mS
V_p	Pinch-off Voltage V _{ds} =3V, I _{ds} =10mA		-2.0	-3.5	V
BV_{gd}	Drain Breakdown Voltage I _{gd} =4.8mA	-12	-15		V
BV_{gs}	Source Breakdown Voltage I _{gs} =4.8mA	-7	-14		V
R_{th}	Thermal Resistance (Au-Sn Eutectic Attach)		12*		°C/W

* Overall R_{th} depends on case mounting.

MAXIMUM RATINGS AT 25°C

SYMBOLS	PARAMETERS	ABSOLUTE ¹	CONTINUOUS ²
V_{ds}	Drain-Source Voltage	12V	8V
V_{gs}	Gate-Source Voltage	-8V	-4V
I_{ds}	Drain Current	I _{dss}	1.2A
I_{gsf}	Forward Gate Current	120mA	20mA
P_{in}	Input Power	32dBm	@ 3dB Compression
T_{ch}	Channel Temperature	175°C	150°C
T_{stg}	Storage Temperature	-65/175°C	-65/150°C
P_t	Total Power Dissipation	11.4W	9.5W

Note: 1. Exceeding any of the above ratings may result in permanent damage.

2. Exceeding any of the above ratings may reduce MTTF below design goals.

EFA480C-180F

PRELIMINARY DATA SHEET

Low Distortion GaAs Power FET

S-PARAMETERS

8V, 1/2 Idss

Freq	S11	S11	S21	S21	S12	S12	S22	S22
GHz	Mag	Ang	Mag	Ang	Mag	Ang	Mag	Ang
0.5	0.954	-134.7	9.539	102.9	0.018	29.3	0.630	-174.9
1.0	0.938	-164.9	5.226	79.0	0.020	16.4	0.630	179.6
1.5	0.882	-175.7	4.530	67.5	0.028	17.7	0.516	171.1
2.0	0.861	171.8	3.638	53.3	0.032	12.1	0.492	168.3
2.5	0.841	161.2	3.202	39.7	0.037	6.7	0.442	166.5
3.0	0.803	149.9	3.035	25.1	0.045	0.4	0.379	165.5
3.5	0.764	135.1	3.005	7.5	0.055	-10.9	0.300	162.4
4.0	0.723	114.4	2.994	-13.4	0.066	-25.3	0.214	155.4
4.5	0.703	88.0	2.920	-36.5	0.075	-43.1	0.130	131.4
5.0	0.713	58.4	2.750	-60.8	0.080	-62.2	0.099	66.1
5.5	0.743	28.7	2.518	-85.6	0.084	-81.5	0.169	14.7
6.0	0.777	-1.5	2.234	-110.9	0.083	-102.4	0.270	-12.2
6.5	0.821	-32.0	1.905	-137.2	0.074	-125.2	0.371	-31.6
7.0	0.869	-60.0	1.512	-163.1	0.059	-145.1	0.478	-53.6
7.5	0.904	-82.1	1.135	174.4	0.042	-159.2	0.583	-71.4
8.0	0.917	-99.2	0.843	156.8	0.032	-163.7	0.669	-83.3
8.5	0.939	-113.8	0.658	141.4	0.020	-170.7	0.740	-89.3
9.0	0.916	-128.3	0.508	126.9	0.027	-130.2	0.759	-95.1
9.5	0.913	-137.0	0.442	117.1	0.041	-178.4	0.740	-102.2
10.0	0.925	-147.2	0.391	99.8	0.030	150.6	0.741	-118.3