150 mA Low Voltage Dual-Channel LDO Regulator with Two Input Pins

NO.EA-201-150901

OUTLINE

The RP153L is a 150 mA dual-channel LDO regulator that provides high ripple rejection, low dropout voltage, high output voltage accuracy, and low supply current. Internally, the RP153L consists of a voltage reference unit, an error amplifier, resistors for setting output voltage, a short current limit circuit, and a chip enable circuit.

The RP153L is available in fixed output voltage options. Besides the low supply current by CMOS, the RP153L offers a low dropout voltage by built-in low ON resistance r_{ON} as well as an extended battery life by a chip enable function. Compared with the existing CMOS-based regulators, the RP153L is further improved in ripple rejection, line transient response, and load transient response. All these features allow the RP153L to become ideal power sources for hand-held communication equipment.

The RP153L is offered in an 8-pin DFN1216-8 package which can achieve high-density mounting.

FEATURES

- Supply Current RP153LxxxA/ B: Typ. 40 μ A x 2
RP153LxxxD/ E: Typ. 85 μ A x 2
- Standby Current Typ. 0.1 μ A x 2
- Ripple Rejection Typ. 70 dB, f = 1 kHz
- Input Voltage Range 1.4 V to 5.25 V
- Output Voltage Range 0.8 V to 3.6 V, 0.1 V step
- Output Voltage Accuracy $\pm 1.0\%$, $V_{SET} > 2.0$ V, $T_a = 25^\circ$ C
- Temperature-Drift Coefficient of Output Voltage Typ. ± 80 ppm/ $^\circ$ C
- Dropout Voltage Typ. 0.20 V, $I_{OUT} = 150$ mA, $V_{SET} = 2.8$ V
- Line Regulation Typ. 0.02%/ V
- Package DFN1216-8
- Short-current Limit Typ. 40 mA
- Overcurrent Protection
- Ceramic Capacitor Compatible 0.22 μ F or more

APPLICATIONS

- Battery-powered Equipment
- Portable Communication Equipment, Camera
- Home Electrical Appliances

RP153L

NO.EA-201-150901

SELECTION GUIDE

The set output voltage, the auto discharge function¹ and the improved transient response are user-selectable options.

Selection Guide

Product Name	Package	Quantity per Reel	Pb Free	Halogen Free
RP153Lxxx*-E2	DFN1216-8	5,000 pcs	Yes	Yes

xxx: Specify the combination of set output voltage (V_{SET}) within the range of 0.8 V to 3.6 V in 0.1 V step.
Refer to *MARKING SPECIFICATON* in *SUPPLEMENTARY ITEMS* for detailed information.

*: Specify the auto-discharge option and the improved transient response option.

(A) Auto-discharge function not included

(B) Auto-discharge function included

(D) Transient response improved, Auto-discharge function not included

(E) Transient response improved, Auto-discharge function included

¹ Auto-discharge function quickly lowers the output voltage to 0 V by releasing the electrical charge accumulated in the external capacitor when the chip enable signal is switched from the active mode to the standby mode.

BLOCK DIAGRAMS

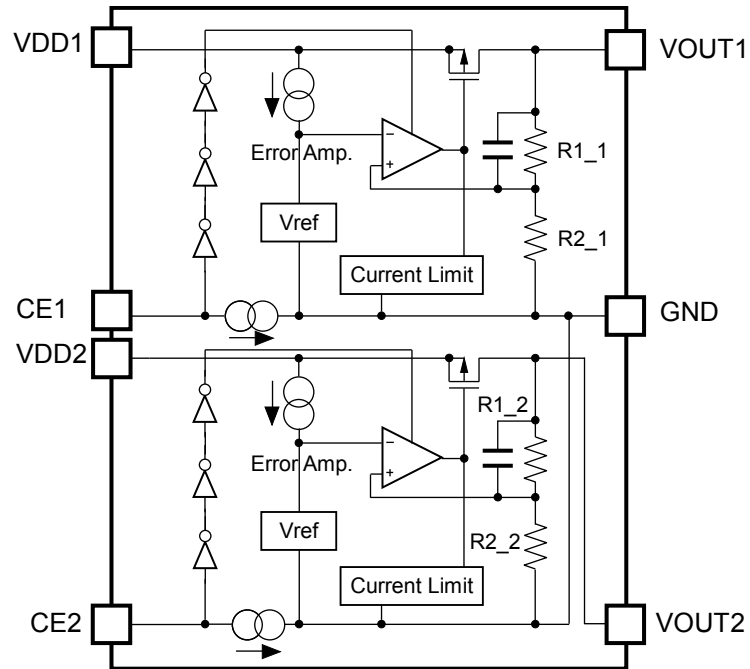

RP153LxxxA/ D Block Diagram

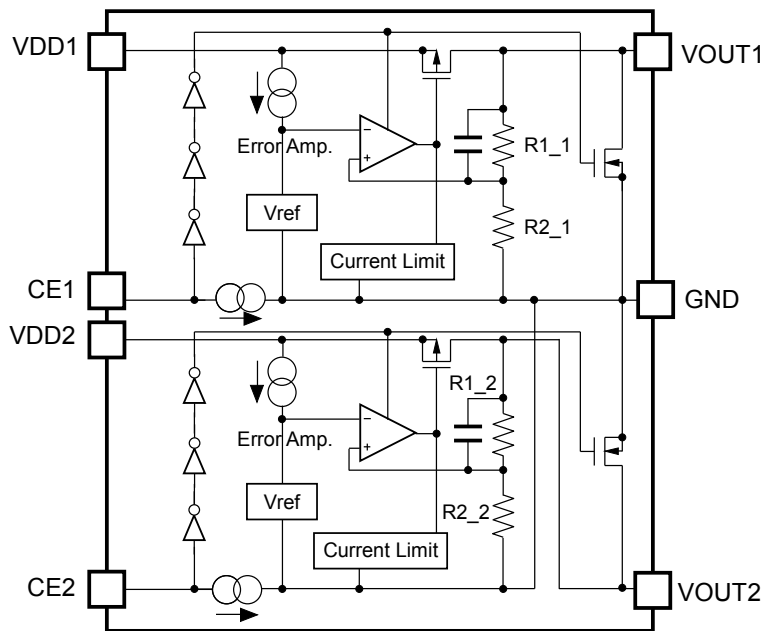

RP153LxxxB/ E Block Diagram

RP153L

NO.EA-201-150901

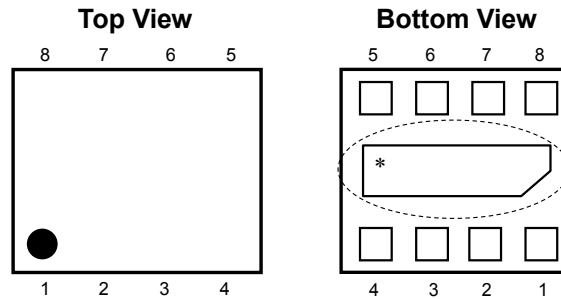
PIN DESCRIPTIONS**DFN1216-8 Pin Configuration****DFN1216-8 Pin Description**

Pin No.	Symbol	Description
1	GND	Ground Pin
2	VOUT1	Output Pin 1
3	VOUT2	Output Pin 2
4	GND	Ground Pin
5	CE2	Chip Enable Pin 2, Active-high
6	VDD2	Input Pin 2
7	VDD1	Input Pin 1
8	CE1	Chip Enable Pin 1, Active-high

* The tab on the bottom of the package enhances thermal performance and is electrically connected to GND (substrate level). It is recommended that the tab be connected to the ground plane on the board, or otherwise be left floating.

ABSOLUTE MAXIMUM RATINGS

Absolute Maximum Ratings

Symbol	Item	Rating	Unit
V_{IN}	Input Voltage	-0.3 to 6.0	V
V_{CE}	CE Pin Input Voltage	-0.3 to 6.0	V
V_{OUT1} V_{OUT2}	Output Voltage	-0.3 to $V_{IN}+0.3$	V
I_{OUT1} I_{OUT2}	Output Current	180	mA
P_D	Power Dissipation (Standard Land Pattern) ¹	625	mW
T_j	Junction Temperature Range	-40 to 125	°C
T_{stg}	Storage Temperature Range	-55 to 125	°C

ABSOLUTE MAXIMUM RATINGS

Electronic and mechanical stress momentarily exceeded absolute maximum ratings may cause the permanent damages and may degrade the life time and safety for both device and system using the device in the field. The functional operation at or over these absolute maximum ratings is not assured.

RECOMMENDED OPERATING CONDITIONS

Recommended Operating Conditions

Symbol	Item	Rating	Unit
V_{IN}	Input Voltage ²	1.40 to 5.25	V
T_a	Operating Temperature Range	-40 to 85	°C

RECOMMENDED OPERATING CONDITIONS

All of electronic equipment should be designed that the mounted semiconductor devices operate within the recommended operating conditions. The semiconductor devices cannot operate normally over the recommended operating conditions, even if when they are used over such conditions by momentary electronic noise or surge. And the semiconductor devices may receive serious damage when they continue to operate over the recommended operating conditions.

¹ Refer to *POWER DISSIPATION* in *SUPPLEMENTARY ITEMS* for detail information.

² In case of operating the device beyond 5.25 V, do not exceed 5.5 V with 500 total operating hours.

RP153L

NO.EA-201-150901

ELECTRICAL CHARACTERISTICS

$V_{IN} = V_{SET} + 1.0 \text{ V}$ ($V_{SET} > 1.5 \text{ V}$), $V_{IN} = 2.5 \text{ V}$ ($V_{SET} \leq 1.5 \text{ V}$), $I_{OUT} = 1 \text{ mA}$, $C_{IN} = C_{OUT} = 0.22 \mu\text{F}$, unless otherwise noted.

The specifications surrounded by are guaranteed by Design Engineering at $-40^\circ\text{C} \leq T_a \leq 85^\circ\text{C}$.

RP153L (VR1/ VR2) Electrical Characteristics

($T_a = 25^\circ\text{C}$)

Symbol	Item	Conditions		Min.	Typ.	Max.	Unit
V_{OUT}	Output Voltage	$T_a = 25^\circ\text{C}$	$V_{SET} > 2.0 \text{ V}$	$\times 0.99$		$\times 1.01$	V
			$V_{SET} \leq 2.0 \text{ V}$	-20		20	mV
		$-40^\circ\text{C} \leq T_a \leq 85^\circ\text{C}$	$V_{SET} > 2.0 \text{ V}$	×0.97		×1.03	V
			$V_{SET} \leq 2.0 \text{ V}$	-60		60	mV
I_{OUT}	Output Current		150			mA	
$\frac{\Delta V_{OUT}}{\Delta I_{OUT}}$	Load Regulation	$1 \text{ mA} \leq I_{OUT} \leq 150 \text{ mA}$		Refer to Product-specific Electrical Characteristics			
V_{DIF}	Dropout Voltage	$I_{OUT} = 150 \text{ mA}$					
I_{SS}	Supply Current	$I_{OUT} = 0 \text{ mA}$	RP153LxxxA/ B		40	60	μA
			RP153LxxxD/ E		85	120	
Istandby	Standby Current	$V_{CE} = 0 \text{ V}$			0.1	1.0	μA
$\frac{\Delta V_{OUT}}{\Delta V_{IN}}$	Line Regulation	$V_{SET} + 0.5 \text{ V} \leq V_{IN} \leq 5.0 \text{ V}$			0.02	0.10	%/V
RR	Ripple Rejection	f = 1 kHz, Ripple 0.2 Vp-p $V_{IN} = V_{SET} + 1.0 \text{ V}$, $I_{OUT} = 30 \text{ mA}$ Notes: $V_{IN} = 3.0 \text{ V}$ when $V_{SET} \leq 2.0 \text{ V}$			70		dB
$\frac{\Delta V_{OUT}}{\Delta T_a}$	Output Voltage Temperature Coefficient	$-40^\circ\text{C} \leq T_a \leq 85^\circ\text{C}$			± 80		ppm/ $^\circ\text{C}$
I_{SC}	Short Current Limit	$V_{SET} = 0 \text{ V}$			40		mA
I_{PD}	CE Pull-down Current				0.3		μA
V_{CEH}	CE Input Voltage "H"			1.0			V
V_{CEL}	CE Input Voltage "L"					0.4	V
en	Output Noise	BW = 10 Hz to 100 kHz			60		μVrms
R_{LOW}	Low Output Nch Tr. ON Resistance (RP153LxxxB/ E)	$V_{IN} = 4.0 \text{ V}$, $V_{CE} = 0 \text{ V}$			50		Ω

All test items listed under *ELECTRICAL CHARACTERISTICS* are done under the pulse load condition ($T_j \approx T_a = 25^\circ\text{C}$) except for Output Noise, Ripple Rejection and Output Voltage Temperature Coefficient.

Product-specific Electrical Characteristics

Product Name	V _{OUT1} (Ta = 25°C)			V _{OUT1} (-40°C ≤ Ta ≤ 85°C)			ΔV _{OUT1} /ΔI _{OUT}		V _{DIF1}	
	Min.	Typ.	Max.	Min.	Typ.	Max.	Typ.	Max.	Typ.	Max.
RP153L001x	2.772	2.800	2.828	2.716	2.800	2.884	15	60	0.200	0.350
RP153L002x	1.780	1.800	1.820	1.740	1.800	1.860	15	55	0.270	0.460
RP153L003x	1.480	1.500	1.520	1.440	1.500	1.560	15	50	0.310	0.550
RP153L004x	1.180	1.200	1.220	1.140	1.200	1.260	15	50	0.390	0.620
RP153L005x	3.267	3.300	3.333	3.201	3.300	3.399	15	60	0.190	0.320
RP153L006x	3.267	3.300	3.333	3.201	3.300	3.399	15	60	0.190	0.320
RP153L007x	2.822	2.850	2.879	2.765	2.850	2.936	15	60	0.200	0.350
RP153L008x	2.822	2.850	2.879	2.765	2.850	2.936	15	60	0.200	0.350
RP153L009x	2.970	3.000	3.030	2.910	3.000	3.090	15	60	0.190	0.320
RP153L010x	2.970	3.000	3.030	2.910	3.000	3.090	15	60	0.190	0.320
RP153L011x	1.780	1.800	1.820	1.740	1.800	1.860	15	55	0.270	0.460
RP153L012x	2.772	2.800	2.828	2.716	2.800	2.884	15	60	0.200	0.350
RP153L013x	3.267	3.300	3.333	3.201	3.300	3.399	15	60	0.190	0.320
RP153L014x	3.267	3.300	3.333	3.201	3.300	3.399	15	60	0.190	0.320
RP153L015x	1.480	1.500	1.520	1.440	1.500	1.560	15	50	0.310	0.550
RP153L016x	1.480	1.500	1.520	1.440	1.500	1.560	15	50	0.310	0.550
RP153L017x	2.475	2.500	2.525	2.425	2.500	2.575	15	60	0.200	0.350
RP153L018x	1.780	1.800	1.820	1.740	1.800	1.860	15	55	0.270	0.460
RP153L019x	1.480	1.500	1.520	1.440	1.500	1.560	15	50	0.310	0.550
RP153L020x	2.772	2.800	2.828	2.716	2.800	2.884	15	60	0.200	0.350
RP153L021x	1.180	1.200	1.220	1.140	1.200	1.260	15	50	0.390	0.620
RP153L022x	2.772	2.800	2.828	2.716	2.800	2.884	15	60	0.200	0.350
RP153L023x	2.475	2.500	2.525	2.425	2.500	2.575	15	60	0.200	0.350
RP153L024x	3.267	3.300	3.333	3.201	3.300	3.399	15	60	0.190	0.320
RP153L025x	2.970	3.000	3.030	2.910	3.000	3.090	15	60	0.190	0.320
RP153L026x	2.772	2.800	2.828	2.716	2.800	2.884	15	60	0.200	0.350
RP153L027x	2.277	2.300	2.323	2.231	2.300	2.369	15	60	0.230	0.390
RP153L028x	2.772	2.800	2.828	2.716	2.800	2.884	15	60	0.200	0.350
RP153L029x	1.480	1.500	1.520	1.440	1.500	1.560	15	50	0.310	0.550
RP153L030x	1.480	1.500	1.520	1.440	1.500	1.560	15	50	0.310	0.550
RP153L031x	1.780	1.800	1.820	1.740	1.800	1.860	15	55	0.270	0.460
RP153L032x	1.180	1.200	1.220	1.140	1.200	1.260	15	50	0.390	0.620
RP153L033x	3.069	3.100	3.131	3.007	3.100	3.193	15	60	0.190	0.320
RP153L034x	1.780	1.800	1.820	1.740	1.800	1.860	15	55	0.270	0.460
RP153L035x	2.475	2.500	2.525	2.425	2.500	2.575	15	60	0.200	0.350
RP153L036x	1.180	1.200	1.220	1.140	1.200	1.260	15	50	0.390	0.620
RP153L037x	3.267	3.300	3.333	3.201	3.300	3.399	15	60	0.190	0.320
RP153L038x	1.180	1.200	1.220	1.140	1.200	1.260	15	50	0.390	0.620
RP153L039x	2.079	2.100	2.121	2.037	2.100	2.163	15	60	0.230	0.390
RP153L040x	2.772	2.800	2.828	2.716	2.800	2.884	15	60	0.200	0.350
RP153L041x	1.780	1.800	1.820	1.740	1.800	1.860	15	55	0.270	0.460
RP153L042x	1.180	1.200	1.220	1.140	1.200	1.260	15	50	0.390	0.620
RP153L043x	1.280	1.300	1.320	1.240	1.300	1.360	15	50	0.390	0.620
RP153L044x	1.080	1.100	1.120	1.040	1.100	1.160	15	50	0.440	0.720
RP153L045x	2.772	2.800	2.828	2.716	2.800	2.884	15	60	0.200	0.350
RP153L046x	2.772	2.800	2.828	2.716	2.800	2.884	15	60	0.200	0.350
RP153L047x	2.475	2.500	2.525	2.425	2.500	2.575	15	60	0.200	0.350
RP153L048x	2.475	2.500	2.525	2.425	2.500	2.575	15	60	0.200	0.350
RP153L049x	1.480	1.500	1.520	1.440	1.500	1.560	15	50	0.310	0.550
RP153L050x	2.376	2.400	2.424	2.328	2.400	2.472	15	60	0.230	0.390
RP153L051x	0.980	1.000	1.020	0.940	1.000	1.060	10	40	0.440	0.720
RP153L052x	1.780	1.800	1.820	1.740	1.800	1.860	15	55	0.270	0.460
RP153L053x	2.574	2.600	2.626	2.522	2.600	2.678	15	60	0.200	0.350
RP153L054x	2.475	2.500	2.525	2.425	2.500	2.575	15	60	0.200	0.350
RP153L055x	2.970	3.000	3.030	2.910	3.000	3.090	15	60	0.190	0.320
RP153L056x	2.574	2.600	2.626	2.522	2.600	2.678	15	60	0.200	0.350

RP153L

NO.EA-201-150901

Product-specific Electrical Characteristics (continued)

Product Name	V _{out2} (Ta = 25°C)			V _{out2} (-40°C ≤ Ta ≤ 85°C)			ΔV _{out2} /ΔI _{out}		V _{DIF2}	
	Min.	Typ.	Max.	Min.	Typ.	Max.	Typ.	Max.	Typ.	Max.
RP153L001x	2.772	2.800	2.828	2.716	2.800	2.884	15	60	0.200	0.350
RP153L002x	2.772	2.800	2.828	2.716	2.800	2.884	15	60	0.200	0.350
RP153L003x	2.772	2.800	2.828	2.716	2.800	2.884	15	60	0.200	0.350
RP153L004x	1.780	1.800	1.820	1.740	1.800	1.860	15	55	0.270	0.460
RP153L005x	1.180	1.200	1.220	1.140	1.200	1.260	15	50	0.390	0.620
RP153L006x	1.780	1.800	1.820	1.740	1.800	1.860	15	55	0.270	0.460
RP153L007x	2.822	2.850	2.879	2.765	2.850	2.936	15	60	0.200	0.350
RP153L008x	2.574	2.600	2.626	2.522	2.600	2.678	15	60	0.200	0.350
RP153L009x	2.772	2.800	2.828	2.716	2.800	2.884	15	60	0.200	0.350
RP153L010x	1.780	1.800	1.820	1.740	1.800	1.860	15	55	0.270	0.460
RP153L011x	1.480	1.500	1.520	1.440	1.500	1.560	15	50	0.310	0.550
RP153L012x	2.574	2.600	2.626	2.522	2.600	2.678	15	60	0.200	0.350
RP153L013x	2.772	2.800	2.828	2.716	2.800	2.884	15	60	0.200	0.350
RP153L014x	3.267	3.300	3.333	3.201	3.300	3.399	15	60	0.190	0.320
RP153L015x	2.475	2.500	2.525	2.425	2.500	2.575	15	60	0.200	0.350
RP153L016x	2.970	3.000	3.030	2.910	3.000	3.090	15	60	0.190	0.320
RP153L017x	2.970	3.000	3.030	2.910	3.000	3.090	15	60	0.190	0.320
RP153L018x	1.780	1.800	1.820	1.740	1.800	1.860	15	55	0.270	0.460
RP153L019x	2.574	2.600	2.626	2.522	2.600	2.678	15	60	0.200	0.350
RP153L020x	1.780	1.800	1.820	1.740	1.800	1.860	15	55	0.270	0.460
RP153L021x	2.772	2.800	2.828	2.716	2.800	2.884	15	60	0.200	0.350
RP153L022x	1.180	1.200	1.220	1.140	1.200	1.260	15	50	0.390	0.620
RP153L023x	2.475	2.500	2.525	2.425	2.500	2.575	15	60	0.200	0.350
RP153L024x	2.970	3.000	3.030	2.910	3.000	3.090	15	60	0.190	0.320
RP153L025x	2.970	3.000	3.030	2.910	3.000	3.090	15	60	0.190	0.320
RP153L026x	3.069	3.100	3.131	3.007	3.100	3.193	15	60	0.190	0.320
RP153L027x	2.772	2.800	2.828	2.716	2.800	2.884	15	60	0.200	0.350
RP153L028x	0.980	1.000	1.020	0.940	1.000	1.060	10	40	0.440	0.720
RP153L029x	1.480	1.500	1.520	1.440	1.500	1.560	15	50	0.310	0.550
RP153L030x	3.267	3.300	3.333	3.201	3.300	3.399	15	60	0.190	0.320
RP153L031x	2.673	2.700	2.727	2.619	2.700	2.781	15	60	0.200	0.350
RP153L032x	2.970	3.000	3.030	2.910	3.000	3.090	15	60	0.190	0.320
RP153L033x	3.069	3.100	3.131	3.007	3.100	3.193	15	60	0.190	0.320
RP153L034x	2.574	2.600	2.626	2.522	2.600	2.678	15	60	0.200	0.350
RP153L035x	1.180	1.200	1.220	1.140	1.200	1.260	15	50	0.390	0.620
RP153L036x	2.871	2.900	2.929	2.813	2.900	2.987	15	60	0.200	0.350
RP153L037x	1.980	2.000	2.020	1.940	2.000	2.060	15	60	0.270	0.460
RP153L038x	2.822	2.850	2.879	2.765	2.850	2.936	15	60	0.200	0.350
RP153L039x	3.267	3.300	3.333	3.201	3.300	3.399	15	60	0.190	0.320
RP153L040x	2.822	2.850	2.879	2.765	2.850	2.936	15	60	0.200	0.350
RP153L041x	2.970	3.000	3.030	2.910	3.000	3.090	15	60	0.190	0.320
RP153L042x	2.574	2.600	2.626	2.522	2.600	2.678	15	60	0.200	0.350
RP153L043x	2.772	2.800	2.828	2.716	2.800	2.884	15	60	0.200	0.350
RP153L044x	1.480	1.500	1.520	1.440	1.500	1.560	15	50	0.310	0.550
RP153L045x	3.267	3.300	3.333	3.201	3.300	3.399	15	60	0.190	0.320
RP153L046x	2.970	3.000	3.030	2.910	3.000	3.090	15	60	0.190	0.320
RP153L047x	2.772	2.800	2.828	2.716	2.800	2.884	15	60	0.200	0.350
RP153L048x	3.168	3.200	3.232	3.104	3.200	3.296	15	60	0.190	0.320
RP153L049x	2.822	2.850	2.879	2.765	2.850	2.936	15	60	0.200	0.350
RP153L050x	2.871	2.900	2.929	2.813	2.900	2.987	15	60	0.200	0.350
RP153L051x	1.780	1.800	1.820	1.740	1.800	1.860	15	55	0.270	0.460
RP153L052x	2.822	2.850	2.879	2.765	2.850	2.936	15	60	0.200	0.350
RP153L053x	2.673	2.700	2.727	2.619	2.700	2.781	15	60	0.200	0.350
RP153L054x	1.780	1.800	1.820	1.740	1.800	1.860	15	55	0.270	0.460
RP153L055x	2.822	2.850	2.879	2.765	2.850	2.936	15	60	0.200	0.350
RP153L056x	2.970	3.000	3.030	2.910	3.000	3.090	15	60	0.190	0.320

APPLICATION INFORMATION

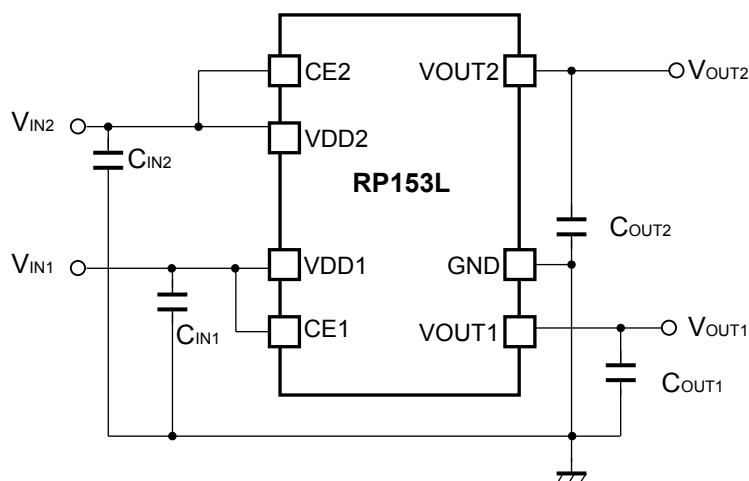

RP153L Typical Application Circuit

External Components

Symbol	Description
C _{IN}	Ceramic, 0.22 μF, Murata: GRM155B31A224KE18B
C _{OUT1}	
C _{OUT2}	

Technical Notes on the Components Selection

- In this device, phase compensation is provided to secure stable operation even when the load current varied. For this purpose, connect 0.22 μF or more output capacitors (C_{OUT1}, C_{OUT2}) between the VOUT and GND pin with shortest-distance wiring. In case of using a tantalum type capacitor and the ESR (Equivalent Series Resistance) value of the capacitor is large, the output might be unstable. Evaluate the circuit including consideration of frequency characteristics.
- Ensure the VDD and GND lines are sufficiently robust. If their impedance is too high, noise pickup or unstable operation may result. Connect a 0.22 μF input capacitor (C_{IN}) between the VDD and GND pins with shortest-distance wiring. Refer to *Typical Application Circuit*.

TYPICAL CHARACTERISTICS

Notes: Typical Characteristics are intended to be used as reference data; they are not guaranteed.

1) Output Voltage vs. Output Current (Ta = 25°C)

0.8 V (VR1/ VR2)

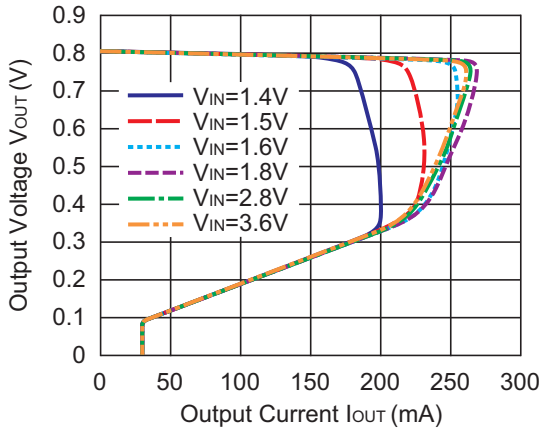

2.5 V (VR1/ VR2)

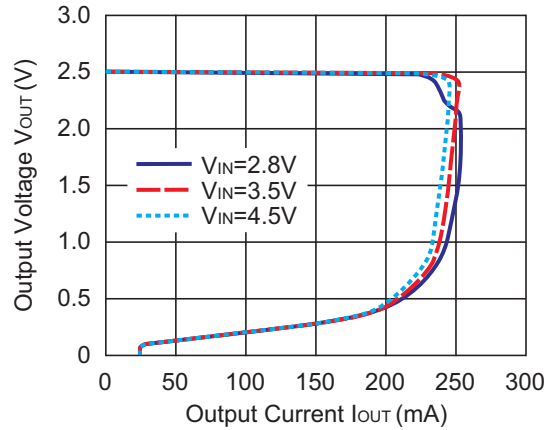

3.6 V (VR1/ VR2)

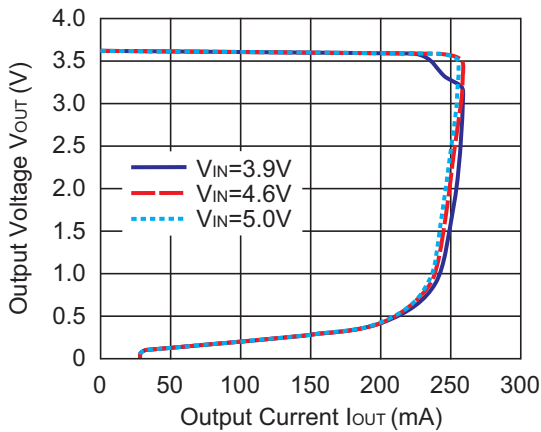

2) Output Voltage vs. Input Voltage (Ta = 25°C)

0.8 V (VR1/ VR2)

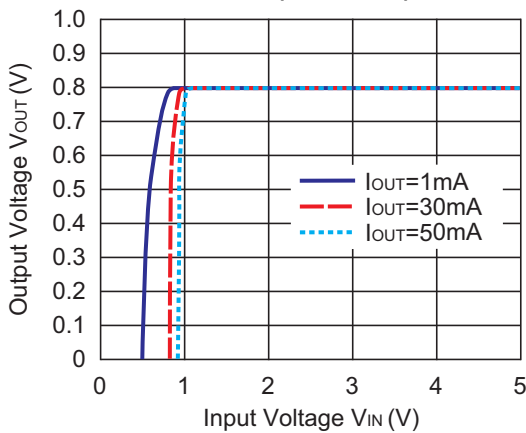

2.5 V (VR1/ VR2)

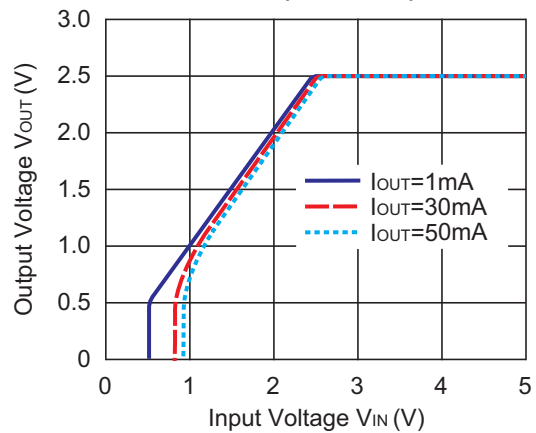

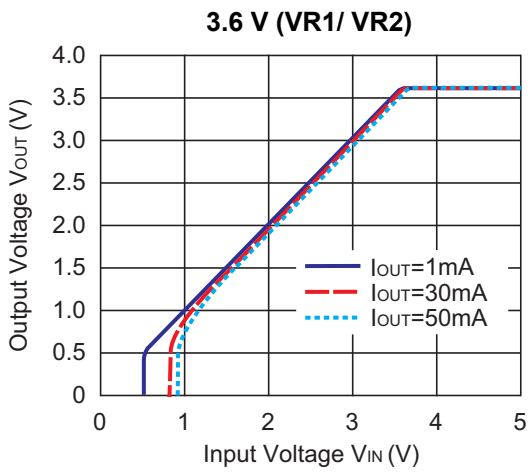

3) Supply Current vs. Input Voltage

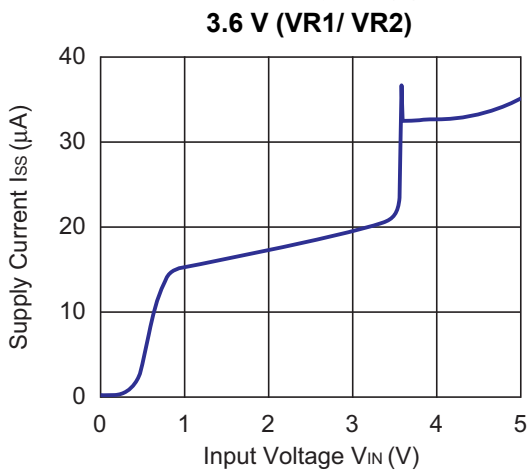
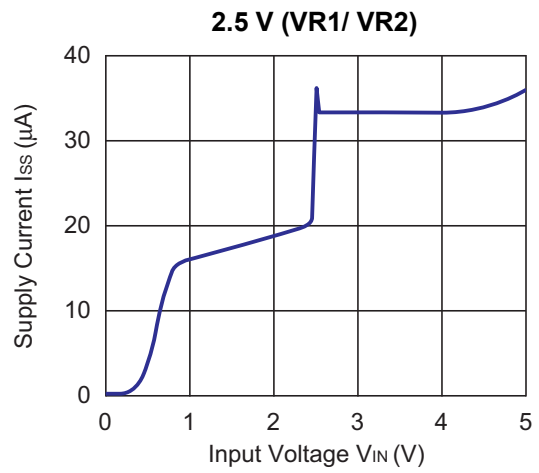
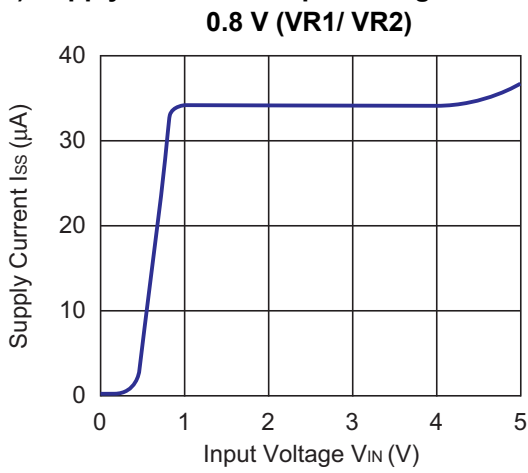

4) Output Voltage vs. Temperature
0.8 V (VR1/ VR2)

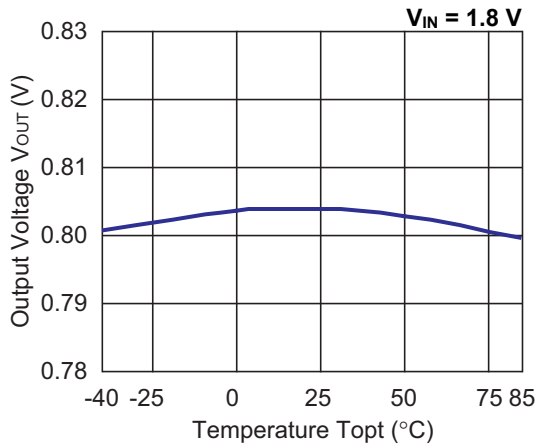

2.5 V (VR1/ VR2)

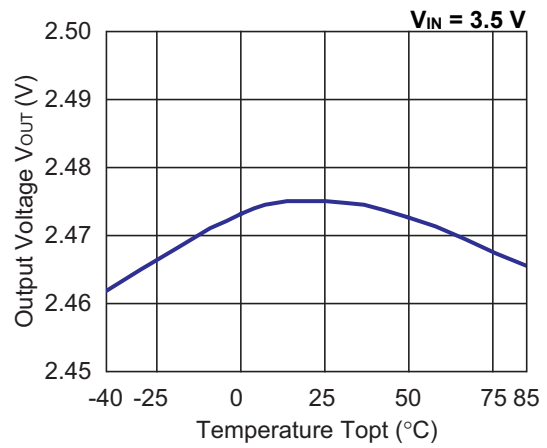

3.6 V (VR1/ VR2)

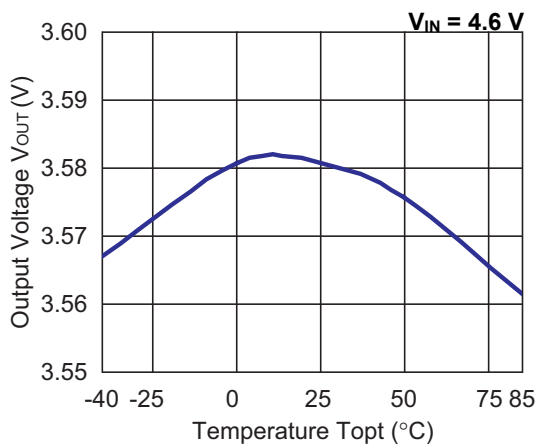

5) Supply Current vs. Temperature
0.8 V (VR1/ VR2)

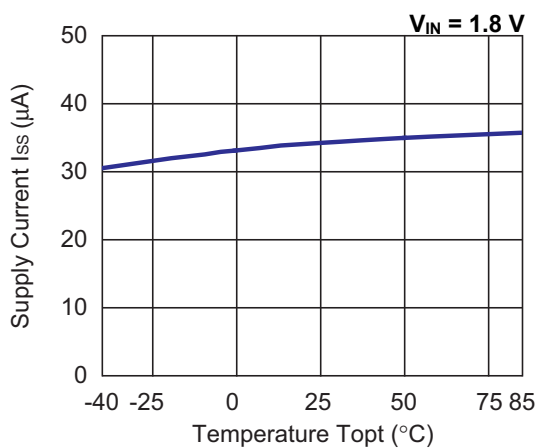

2.5 V (VR1/ VR2)

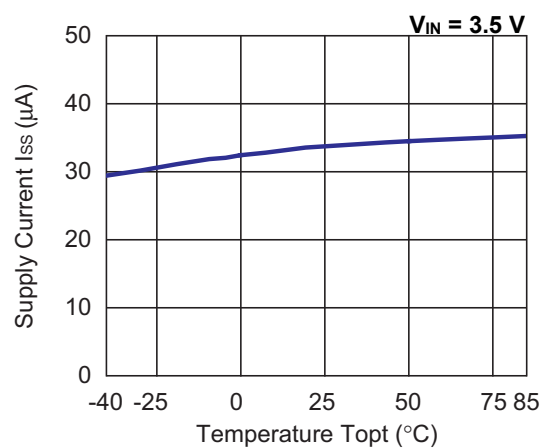

3.6 V (VR1/VR2)

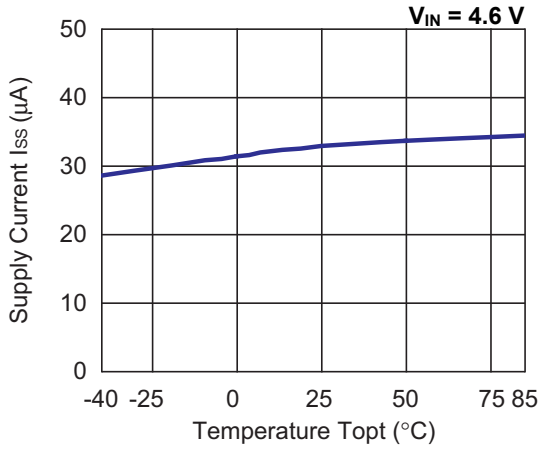

6) Dropout Voltage vs. Output Current
0.8 V (VR1/ VR2)

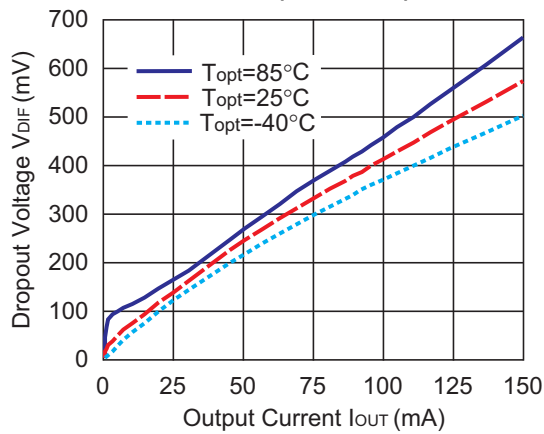

2.5 V (VR1/ VR2)

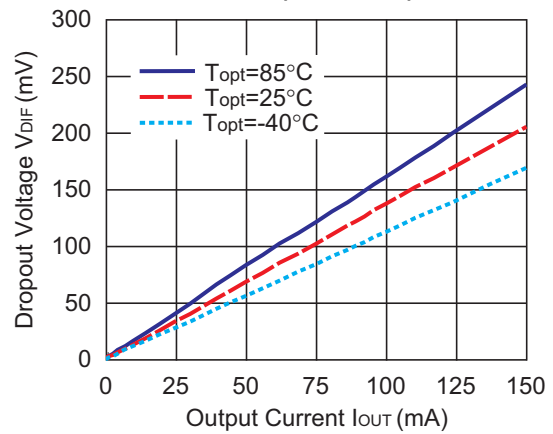

3.6 V (VR1/ VR2)

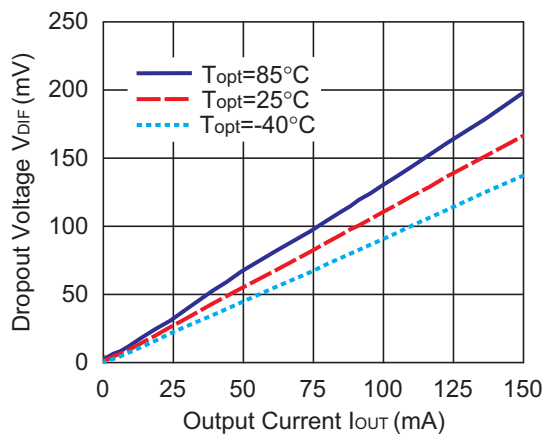

7) Dropout Voltage vs. Set Output Voltage

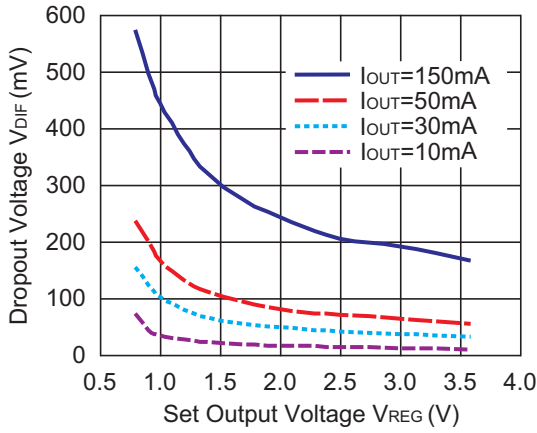

8) Minimum Operating Voltage
0.8 V (VR1/ VR2)

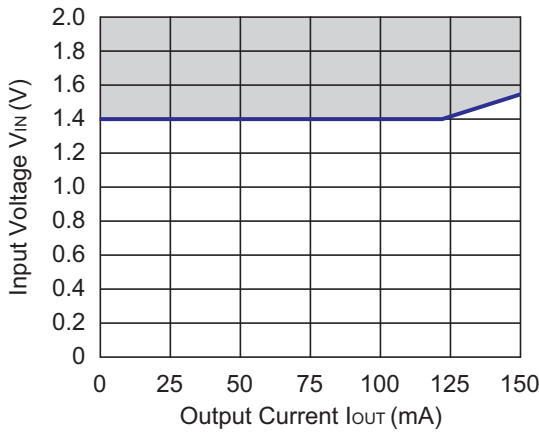

The hatched area is available for a 0.8-V output device.

9) Ripple Rejection vs. Input Voltage

(C_{IN} = none, C_{OUT1} = C_{OUT2} = Ceramic 0.22 μF , Ripple = 0.2 Vp-p, T_a = 25°C)
2.5 V (VR1/ VR2)

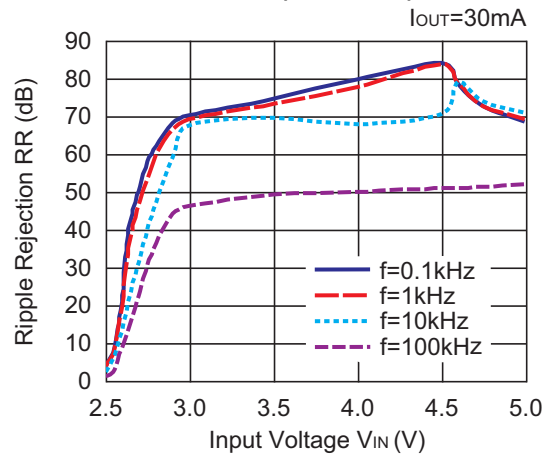
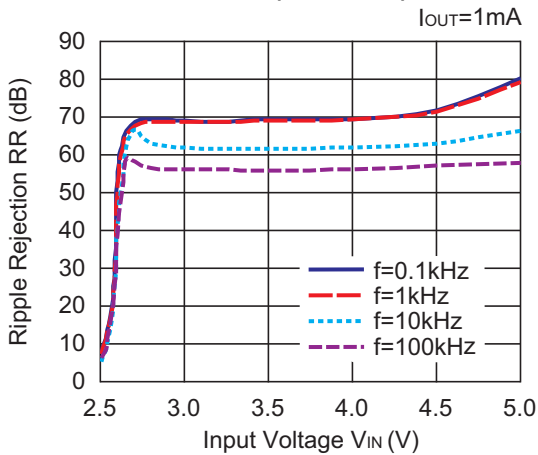

10) Ripple Rejection vs. Frequency

(C_{IN} = none, $C_{OUT1} = C_{OUT2}$ = Ceramic 0.22 μ F, Ripple = 0.2 Vp-p, T_a = 25°C)

0.8 V (VR1/ VR2)

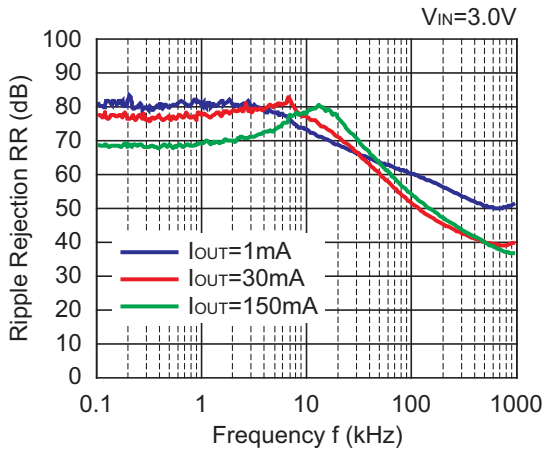

2.5 V (VR1/ VR2)

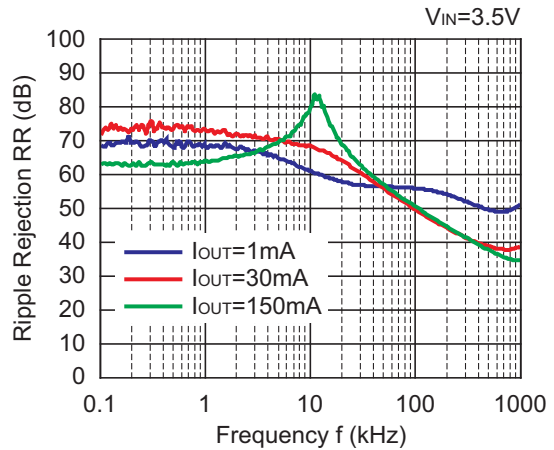

3.6 V (VR1/ VR2)

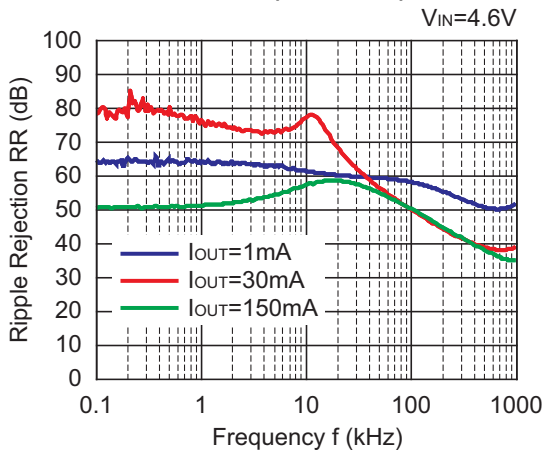

11) Input Transient Response

($I_{OUT} = 30$ mA, $t_r = t_f = 5$ μ s, C_{IN} = none, $C_{OUT1} = C_{OUT2} = 0.22$ μ F, T_a = 25°C)

0.8 V (VR1/ VR2)

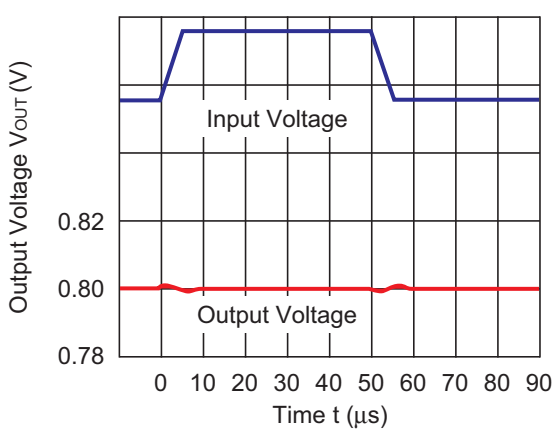

2.5 V (VR1/ VR2)

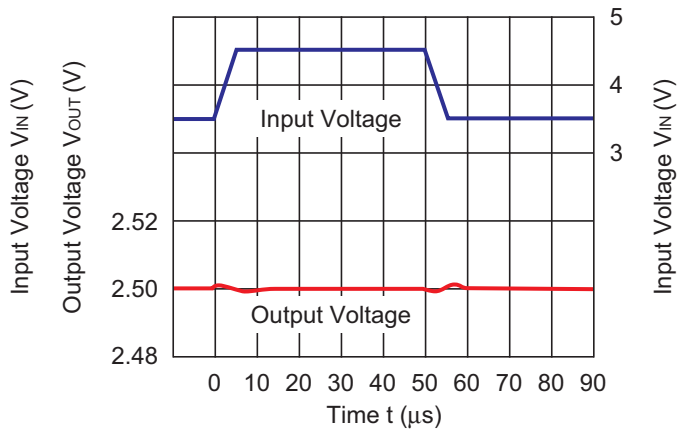

3.6 V (VR1/ VR2)

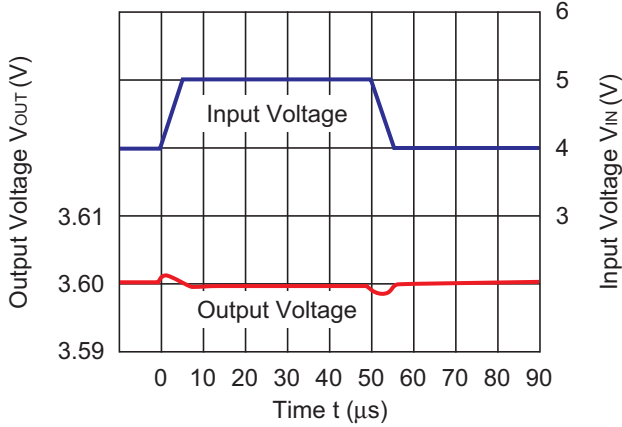

12) Load Transient Response (VR1/ VR2) ($t_r = t_f = 0.5 \mu$ s, $C_{IN} = C_{OUT1} = C_{OUT2} = 0.22 \mu$ F, $T_a = 25^\circ$ C)

0.8 V (RP153LxxxA/ B)

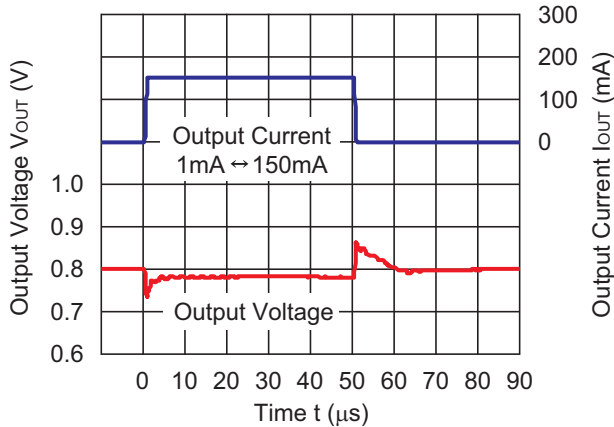

0.8 V (RP153LxxxD/ E)

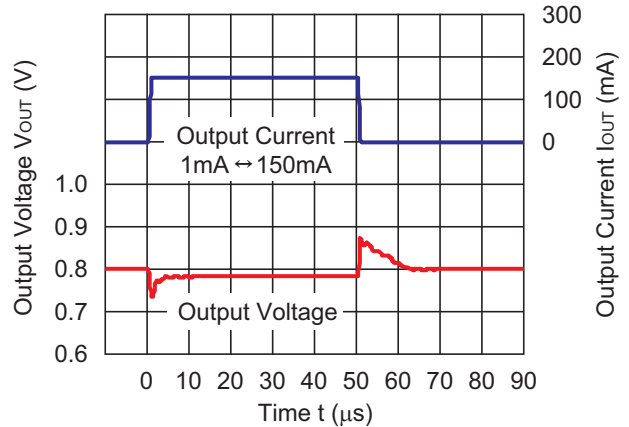

2.5 V (RP153LxxxA/ B)

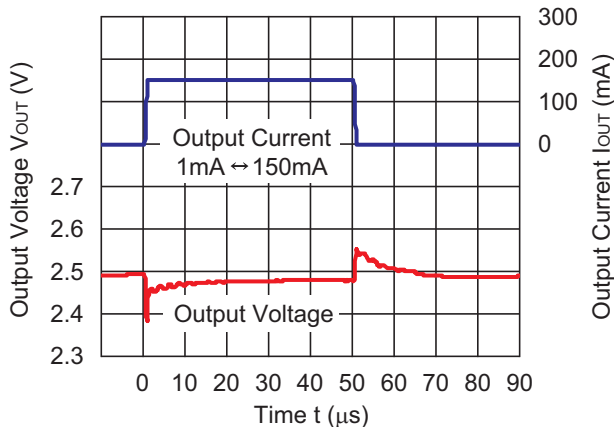

2.5 V (RP153LxxxD/ E)

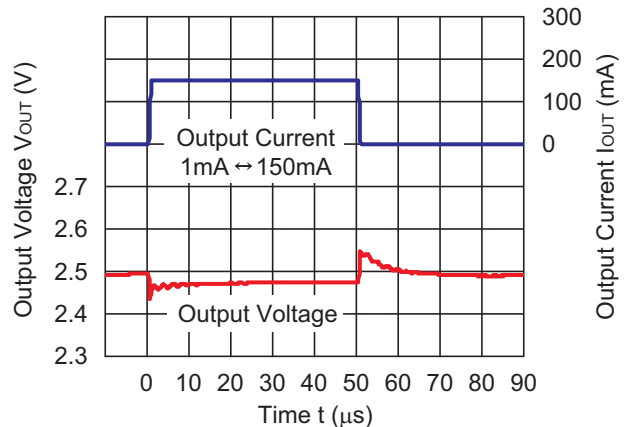

3.6 V (RP153LxxxA/ B)

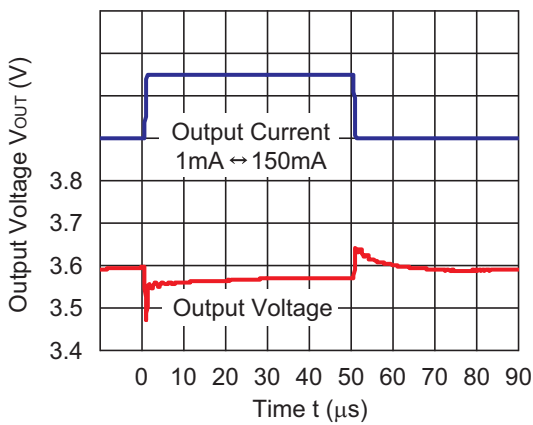

3.6 V (RP153LxxxD/ E)

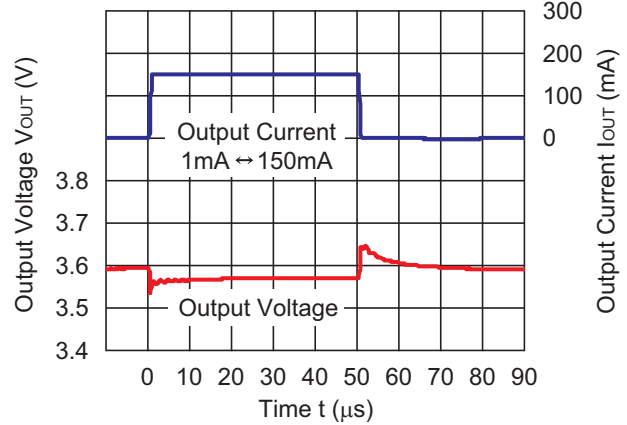

0.8 V (RP153LxxxA/ B)

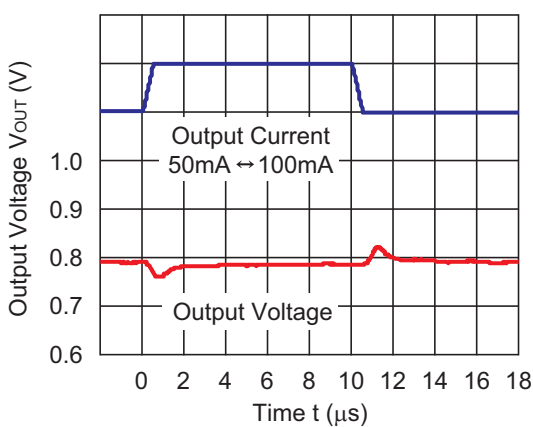

0.8 V (RP153LxxxD/ E)

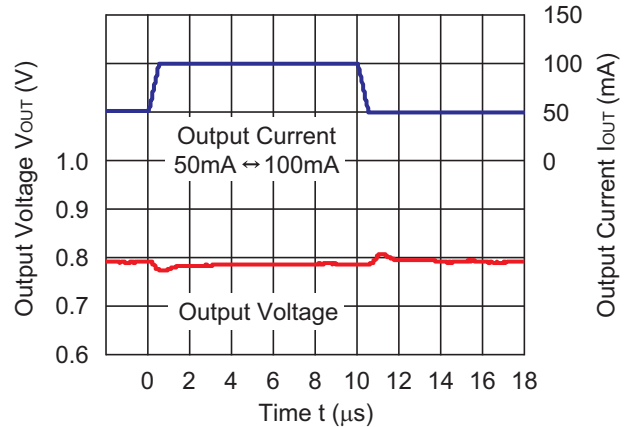

2.5 V (RP153LxxxA/ B)

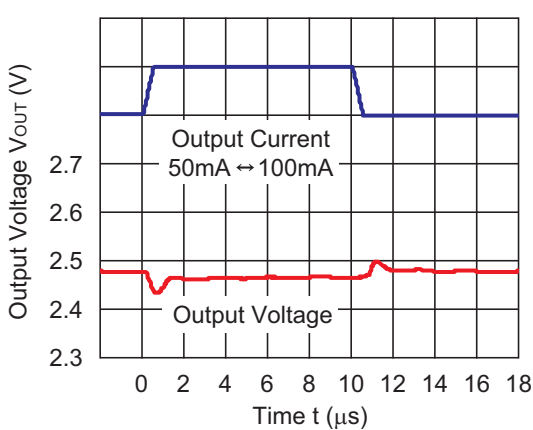

2.5 V (RP153LxxxD/ E)

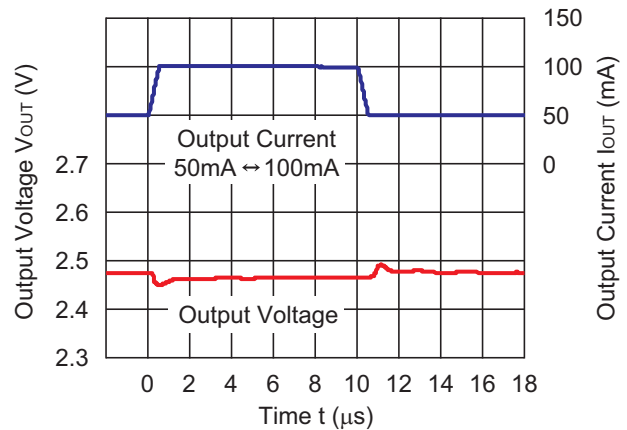

RP153L

NO.EA-201-150901

3.6 V (RP153LxxxA/ B)

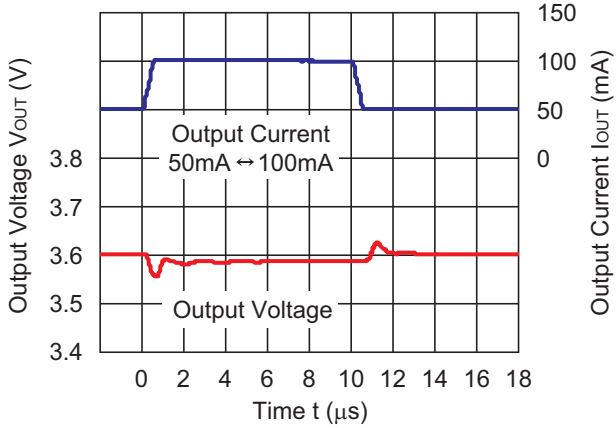

3.6 V (RP153LxxxD/ E)

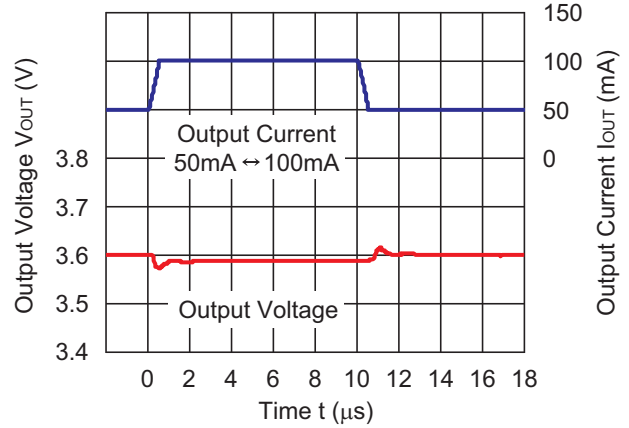

13) Turn On Speed with CE Pin ($C_{IN} = C_{OUT1} = C_{OUT2} = 0.22 \mu F$, $T_a = 25^\circ C$)

0.8 V (RP153LxxxA/ B) (VR1/ VR2)

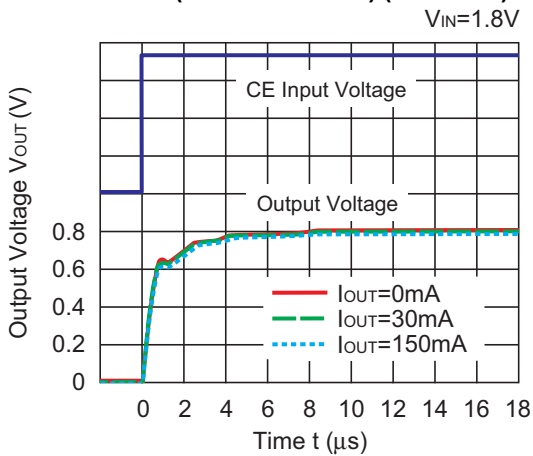

2.5 V (RP153LxxxA/ B) (VR1/ VR2)

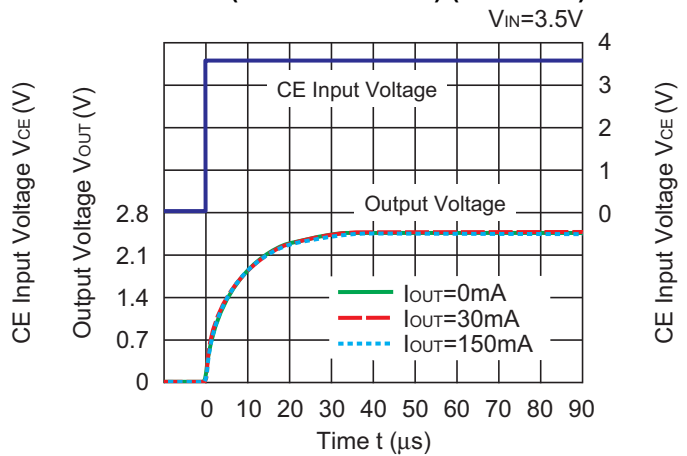

3.6 V (RP153LxxxA/ B) (VR1/ VR2)

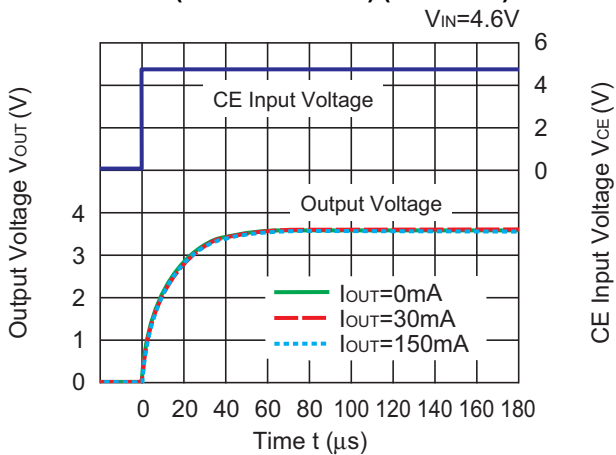

14) Turn Off Speed with CE Pin ($C_{IN} = C_{OUT1} = C_{OUT2} = 0.22 \mu F$, $T_a = 25^\circ C$)

0.8 V (RP153LxxxB) (VR1/ VR2)

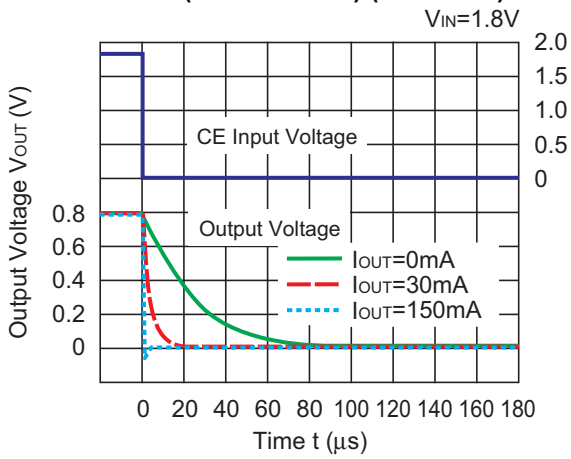

2.5 V (RP153LxxxB) (VR1/ VR2)

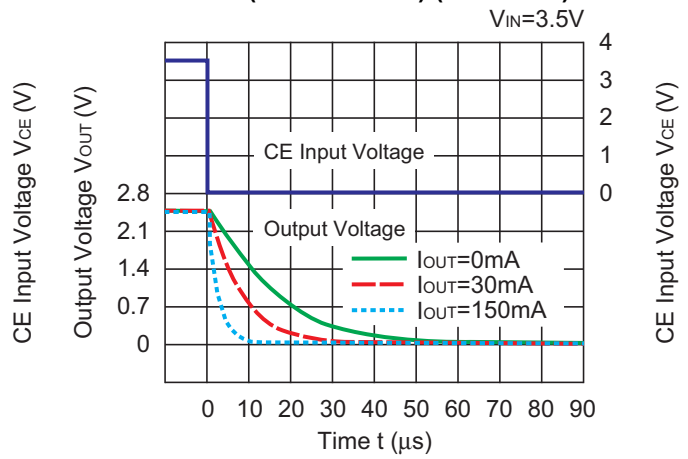

3.6 V (RP153LxxxB) (VR1/ VR2)

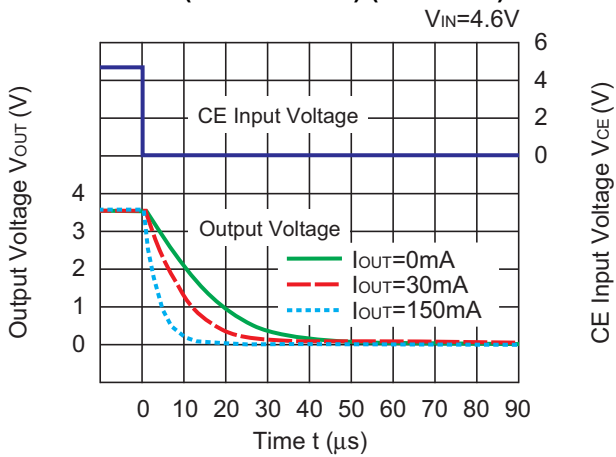

RP153L

NO.EA-201-150901

Equivalent Series Resistance (ESR) vs. Output Current (I_{OUT})

It is recommended that a ceramic type capacitor be used for the RP153L. However, other types of capacitors having lower ESR can also be used. The relation between I_{OUT} and the ESR of output capacitor is shown below.

Measurement Conditions:

- Noise Frequency Band: 10 Hz to 2 MHz
- Measurement Temperature: -40°C to $+85^{\circ}\text{C}$
- Hatched Area: Noise level is $40\ \mu\text{V}$ (avg.) or below.
- C_{IN} , C_{OUT1} , C_{OUT2} : $0.22\ \mu\text{F}$ (Murata: GRM155B10J224KE01)

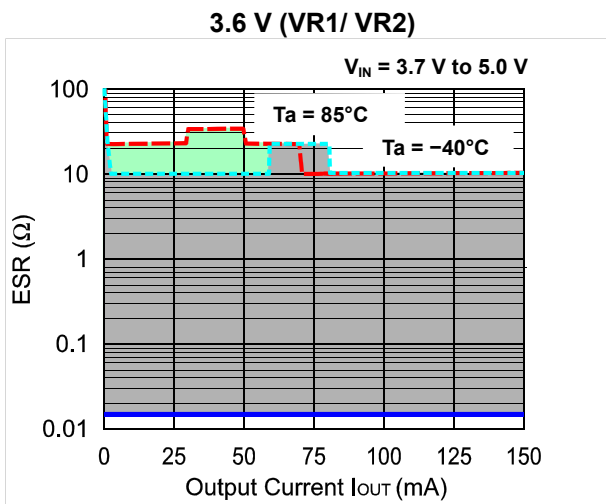
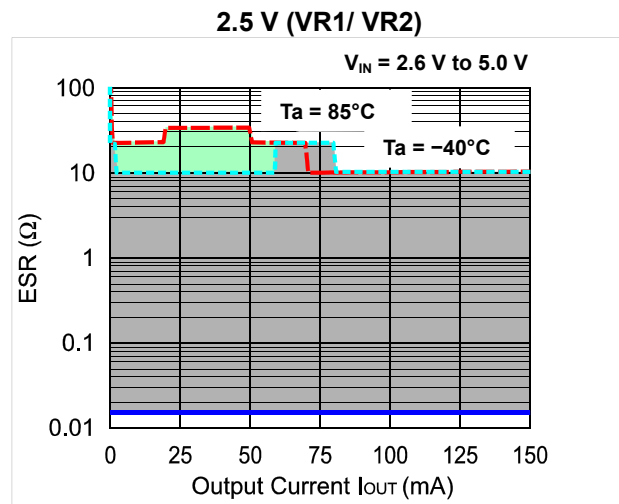
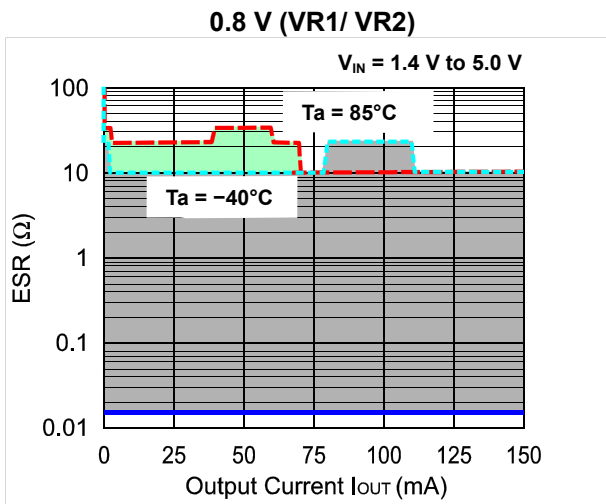

The power dissipation of the package is dependent on PCB material, layout, and environmental conditions. The following conditions are used in this measurement.

Measurement Conditions

	Standard Land Pattern
Environment	Mounting on Board (Wind Velocity = 0 m/s)
Board Material	Glass Cloth Epoxy Plastic (Double-sided)
Board Dimensions	40 mm x 40 mm x 1.6 mm
Copper Ratio	Top-side: Approx. 50%, Back-side: Approx. 50%
Through-holes	φ: 0.5 mm x 28 pcs

Measurement Result

(Ta = 25°C, Tjmax = 125°C)

	Standard Land Pattern
Power Dissipation	625 mW
Thermal Resistance	$\theta_{ja} = (125 - 25^\circ\text{C}) / 0.625 \text{ W} = 160^\circ\text{C/W}$
	$\theta_{jc} = 26^\circ\text{C/W}$

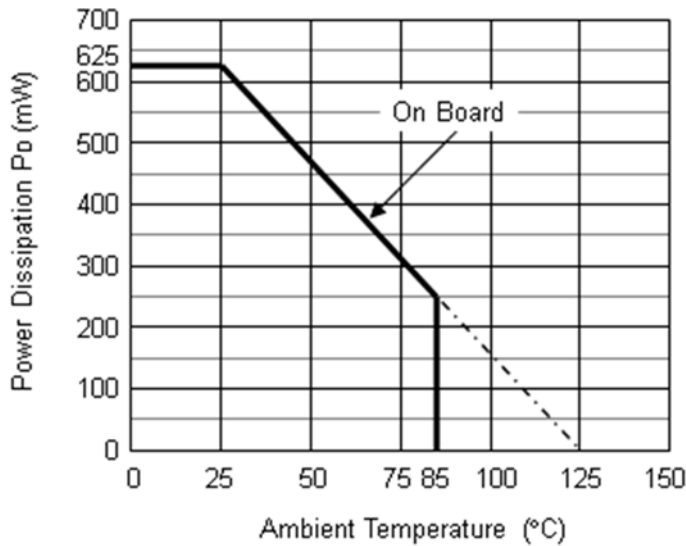

Power Dissipation vs. Ambient Temperature

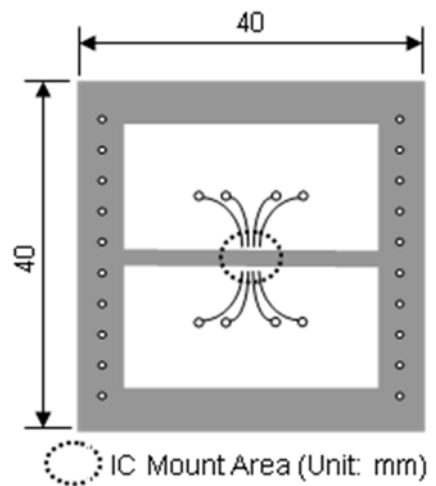

Measurement Board Pattern

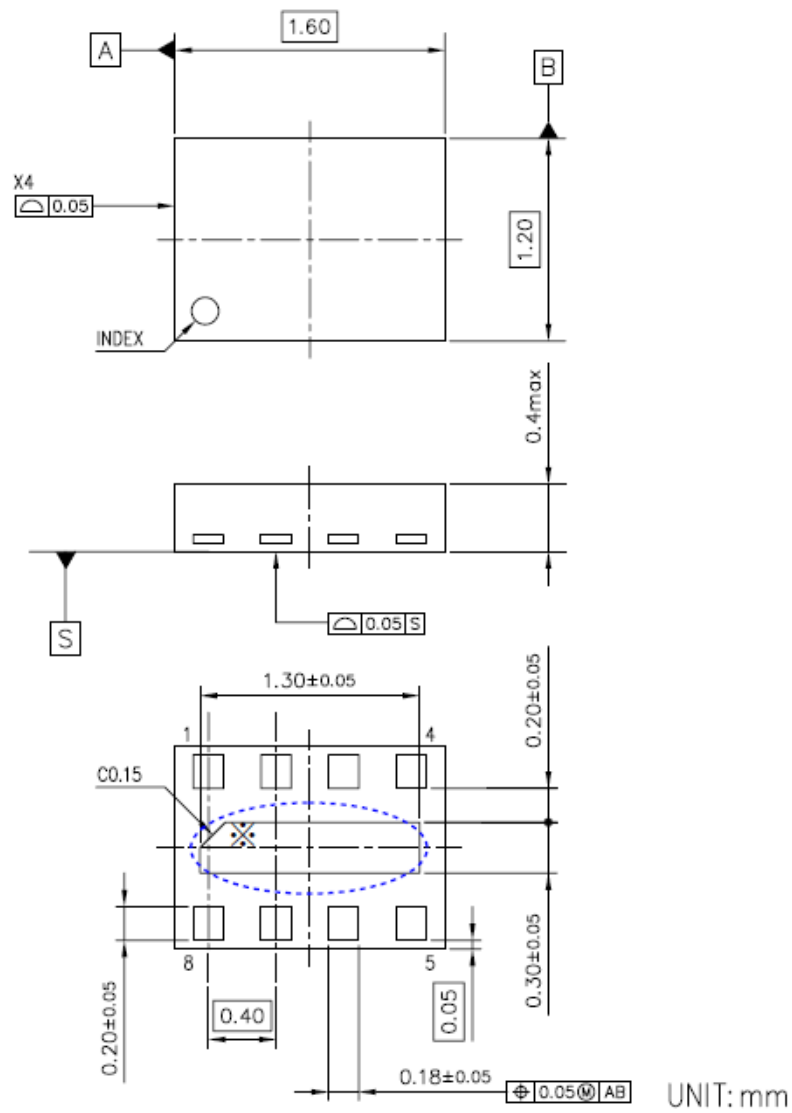

※ The tab on the bottom of the package enhances thermal performance and is electrically connected to GND (substrate level). It is recommended that the tab be connected to the ground plane on the board, or otherwise be left floating.

DFN1216-8 Package Dimensions



1. The products and the product specifications described in this document are subject to change or discontinuation of production without notice for reasons such as improvement. Therefore, before deciding to use the products, please refer to Ricoh sales representatives for the latest information thereon.
2. The materials in this document may not be copied or otherwise reproduced in whole or in part without prior written consent of Ricoh.
3. Please be sure to take any necessary formalities under relevant laws or regulations before exporting or otherwise taking out of your country the products or the technical information described herein.
4. The technical information described in this document shows typical characteristics of and example application circuits for the products. The release of such information is not to be construed as a warranty of or a grant of license under Ricoh's or any third party's intellectual property rights or any other rights.
5. The products listed in this document are intended and designed for use as general electronic components in standard applications (office equipment, telecommunication equipment, measuring instruments, consumer electronic products, amusement equipment etc.). Those customers intending to use a product in an application requiring extreme quality and reliability, for example, in a highly specific application where the failure or misoperation of the product could result in human injury or death (aircraft, spacevehicle, nuclear reactor control system, traffic control system, automotive and transportation equipment, combustion equipment, safety devices, life support system etc.) should first contact us.
6. We are making our continuous effort to improve the quality and reliability of our products, but semiconductor products are likely to fail with certain probability. In order to prevent any injury to persons or damages to property resulting from such failure, customers should be careful enough to incorporate safety measures in their design, such as redundancy feature, fire containment feature and fail-safe feature. We do not assume any liability or responsibility for any loss or damage arising from misuse or inappropriate use of the products.
7. Anti-radiation design is not implemented in the products described in this document.
8. Please contact Ricoh sales representatives should you have any questions or comments concerning the products or the technical information.



Ricoh is committed to reducing the environmental loading materials in electrical devices with a view to contributing to the protection of human health and the environment.

Ricoh has been providing RoHS compliant products since April 1, 2006 and Halogen-free products since April 1, 2012.

RICOH RICOH ELECTRONIC DEVICES CO., LTD.

<http://www.e-devices.ricoh.co.jp/en/>

Sales & Support Offices

RICOH ELECTRONIC DEVICES CO., LTD.

Higashi-Shinagawa Office (International Sales)
3-32-3, Higashi-Shinagawa, Shinagawa-ku, Tokyo 140-8655, Japan
Phone: +81-3-5479-2857 Fax: +81-3-5479-0502

RICOH EUROPE (NETHERLANDS) B.V.

Semiconductor Support Centre
Prof. W.H. Keesomlaan 1, 1183 DJ Amstelveen, The Netherlands
Phone: +31-20-5474-309

RICOH ELECTRONIC DEVICES KOREA CO., LTD.

3F, Haesung Bldg. 504, Teheran-ro, Gangnam-gu, Seoul, 135-725, Korea
Phone: +82-2-2135-5700 Fax: +82-2-2051-5713

RICOH ELECTRONIC DEVICES SHANGHAI CO., LTD.

Room 403, No.2 Building, No.690 Bilbo Road, Pu Dong New District, Shanghai 201203,
People's Republic of China
Phone: +86-21-5027-3200 Fax: +86-21-5027-3299

RICOH ELECTRONIC DEVICES CO., LTD.

Taipei office
Room 109, 10F-1, No.51, Hengyang Rd., Taipei City, Taiwan (R.O.C.)
Phone: +886-2-2313-1621/1622 Fax: +886-2-2313-1623