

CONXALL
DATA-CON-X[®]
SEALED USB TYPE A
**PANEL MOUNT
CONNECTORS**

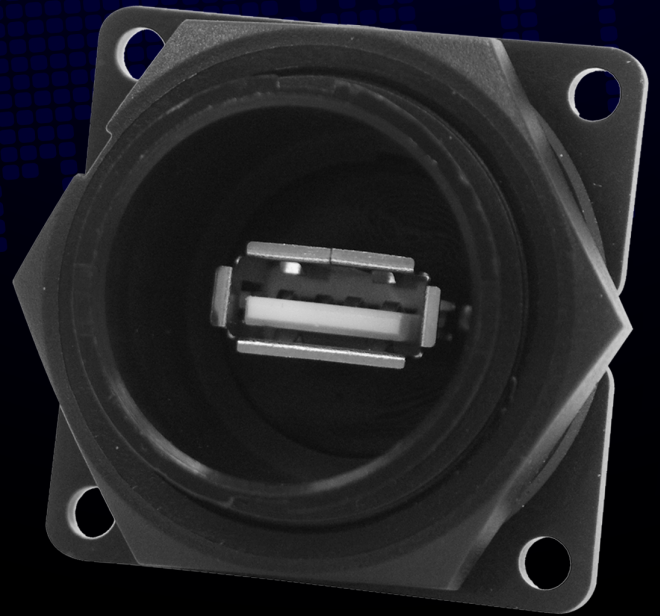

Switchcraft[®]
CONXALL[®]

HARSH ENVIRONMENT CONNECTIVITY SOLUTIONS

OVERALL DIMENSIONS

SOLDER CUP

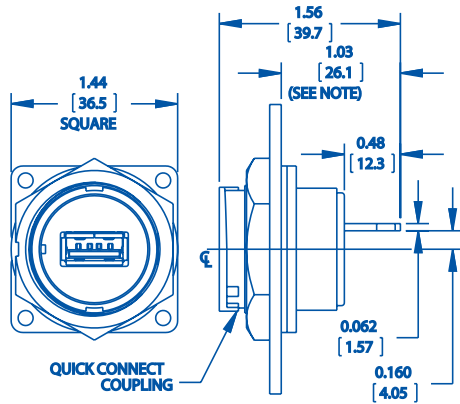

PCB HEADER

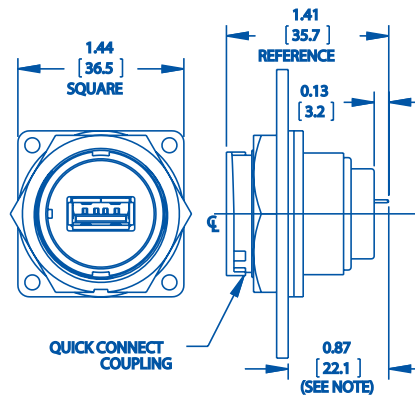

FEEDTHRU

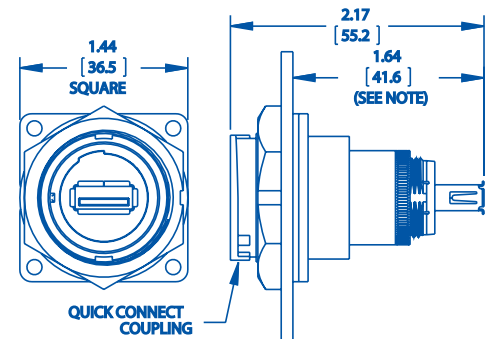

Note: Dimension does not include gasket compression.
Dimensions in inches [mm]. Quick connect option shown.
See drawings from Conxall.com for detailed dimensions

KEY FEATURES

- PC Header, Solder Cup, and Feedthru options available
- Sealed to IP68 when mated with Data-Con-X® USB A connectors
- Also compatible with standard USB A connectors
- Optional IP68 rated cap also available (part #D24295-WA)
- Threaded or Bayonet Quick Connect coupling options
- Built from high quality thermoplastic with elastomer gasket
- Made in the USA

RECOMMENDED PANEL CUTOUT

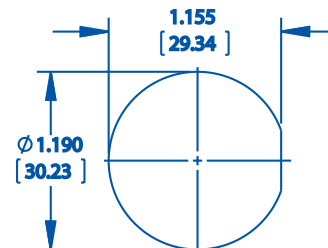

OPTIONS AND PART NUMBER LOGIC



USB PANEL MOUNT FEED-THRU CONNECTORS PART NUMBER CHART

USB FIELD INSTALLABLE PANEL HOUSING ASSEMBLY	RECEPTACLE TYPE (SEALED END)	COUPLING TYPE	RECEPTACLE TYPE (NON-SEALED END)
DCP	USBA = USB "A" 2.0	B = QUICK CONNECT T = THREADED	SC = Solder Cup HD = PCB Header F = USB "A" 2.0 USBB = USB "B" 2.0

DCP-USBAB- mates with DCC-USBAB-150 or DCC-USBAB-180*
DCP-USBAT- mates with DCC-USBAT-150 or DCC-USBAT-180*