

SPECIFICATION

Model No. : **SGGP.25.4.A.02**

Product Name : GPS/GLONASS/GALILEO SMT Patch Antenna

Features : 25mm*25mm*4.5mm
Single Feed SMT Mount
GPS/GALILEO: 1575MHz
GLONASS: 1602MHz
Patent pending
RoHS Compliant



1. Introduction

This ceramic 25mm GPS/GLONASS/GALILEO patch antenna is mounted via SMT process and has been pre-tuned for a 50*50mm ground plane. Custom part no's tuned for different ground-plane or layout positions and taking into account the specific conditions in your device can be created and supplied by Taoglas.

2. Specification

Original Patch Specification tested on 50*50mm ground plane

No	Parameter	Specification	Notes
1	Range of Receiving Frequency	GPS/GALILEO: 1575.42 MHz \pm 1.023 MHz GLONASS: 1602 \pm 5 MHz	
2	Center Frequency	1592 \pm 3MHz	With 50*50mm ground plane
3	Bandwidth	8MHz min	Return Loss <-10 dB
4	VSWR	1.5 max	Center Frequency
5	Gain at Zenith	GPS/GALILEO: -0.14dBic typ. GLONASS: 1.75dBic typ.	
8	Polarization	RHCP	
9	Impedance	50 Ohms	
10	Frequency Temperature Coefficient (τ_f)	0 \pm 20ppm / oC	-40°C to +85°C
11	Operating Temperature -40°C to +85°C		

**Changes in user groundplane and environment will offset centre frequency

3. Electrical Specifications

3.1. Return Loss, SWR, Impedance, measured on the test fixture

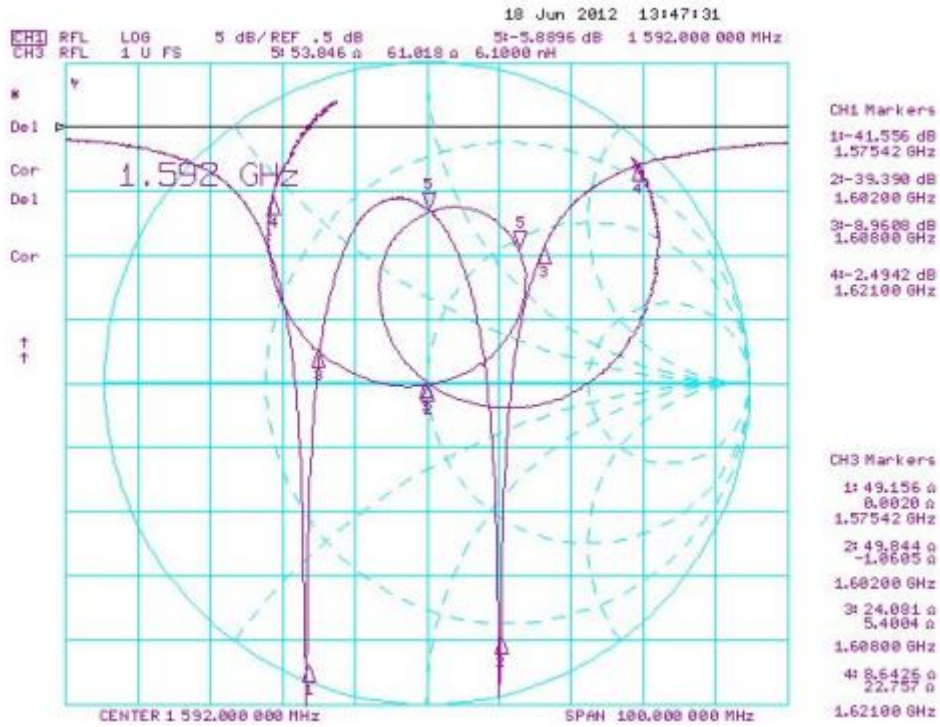

4. Radiation Patterns

4.1. 1575MHz

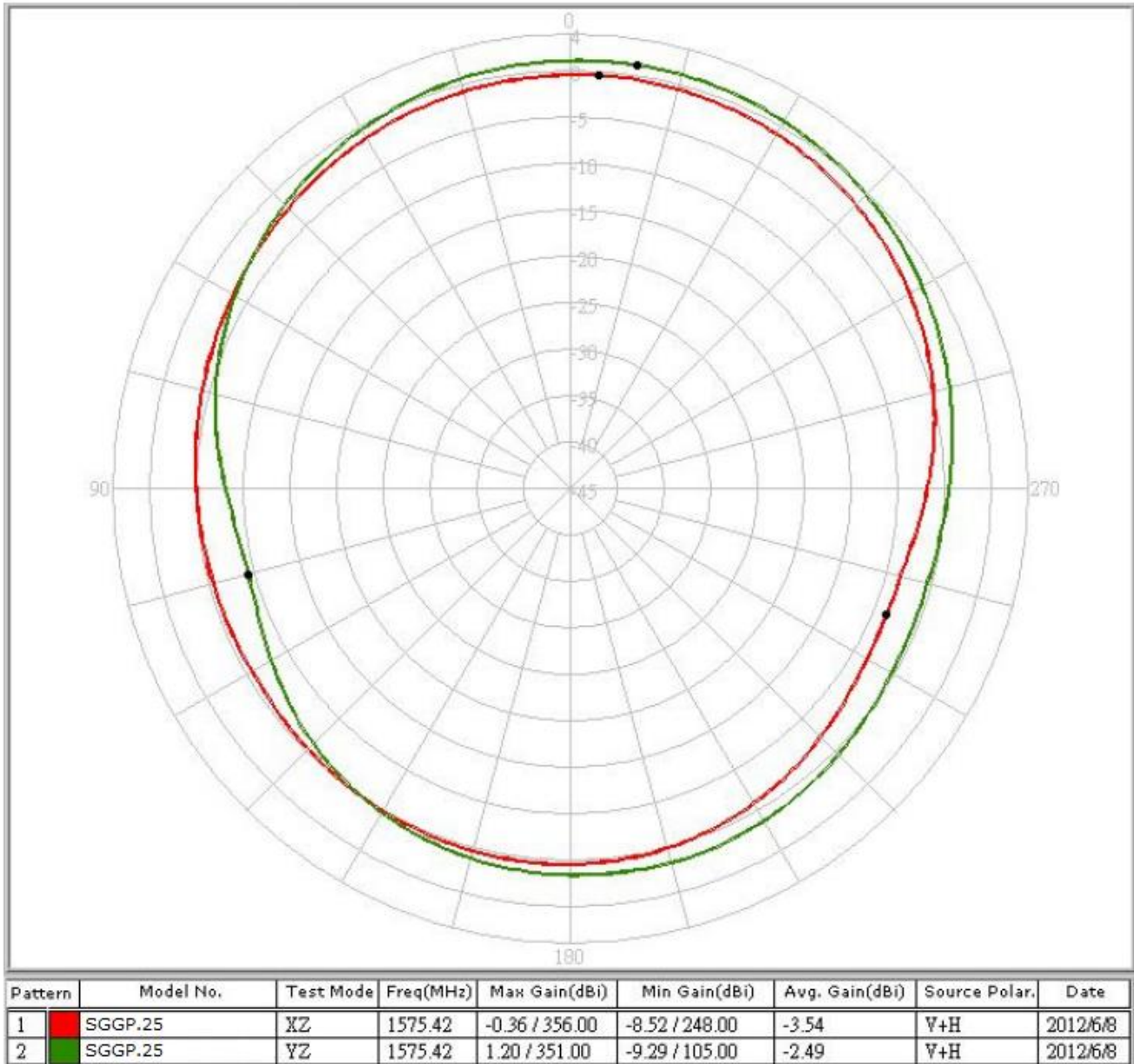

1575.4 MHz XZ+YZ-Plane

4.2. 1602MHz

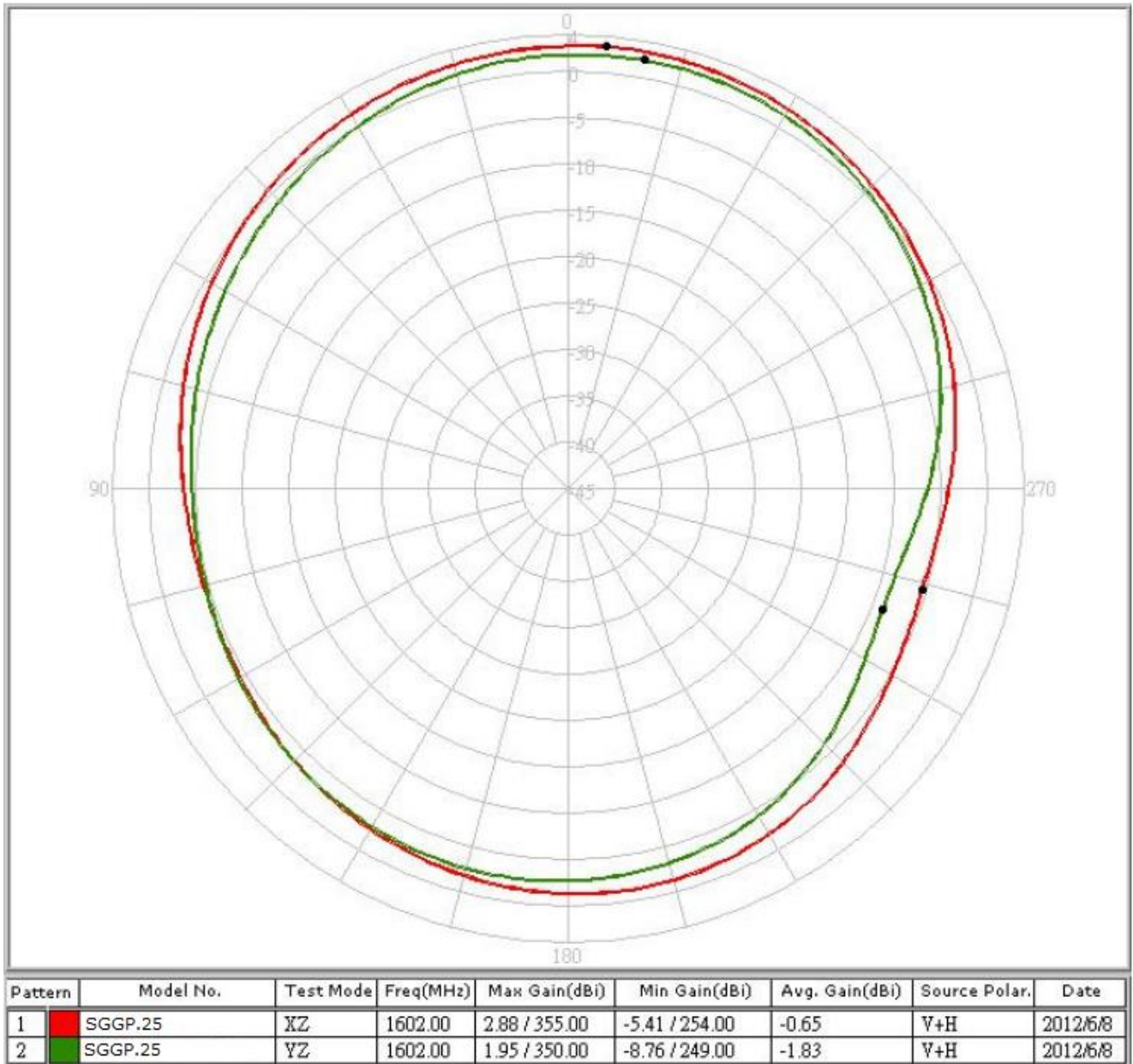

1602.0 MHz XZ+YZ-Plane

5. Mechanical Specifications

5.1. Antenna Dimensions and Drawing

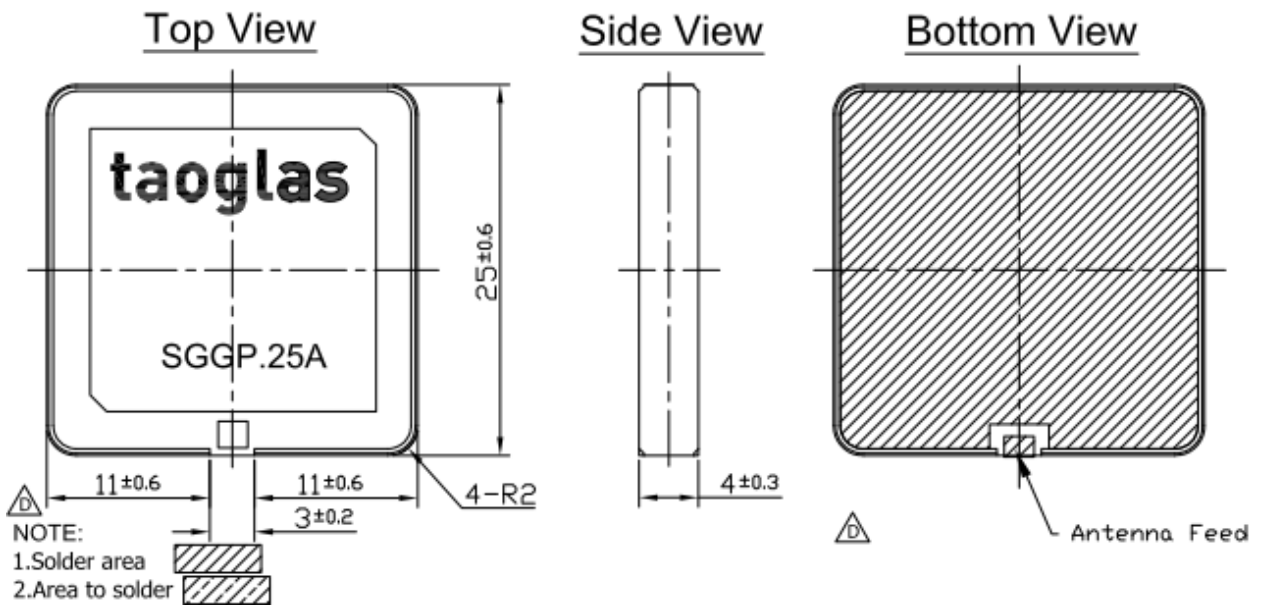

5.2. Footprint Copper Keepout Area

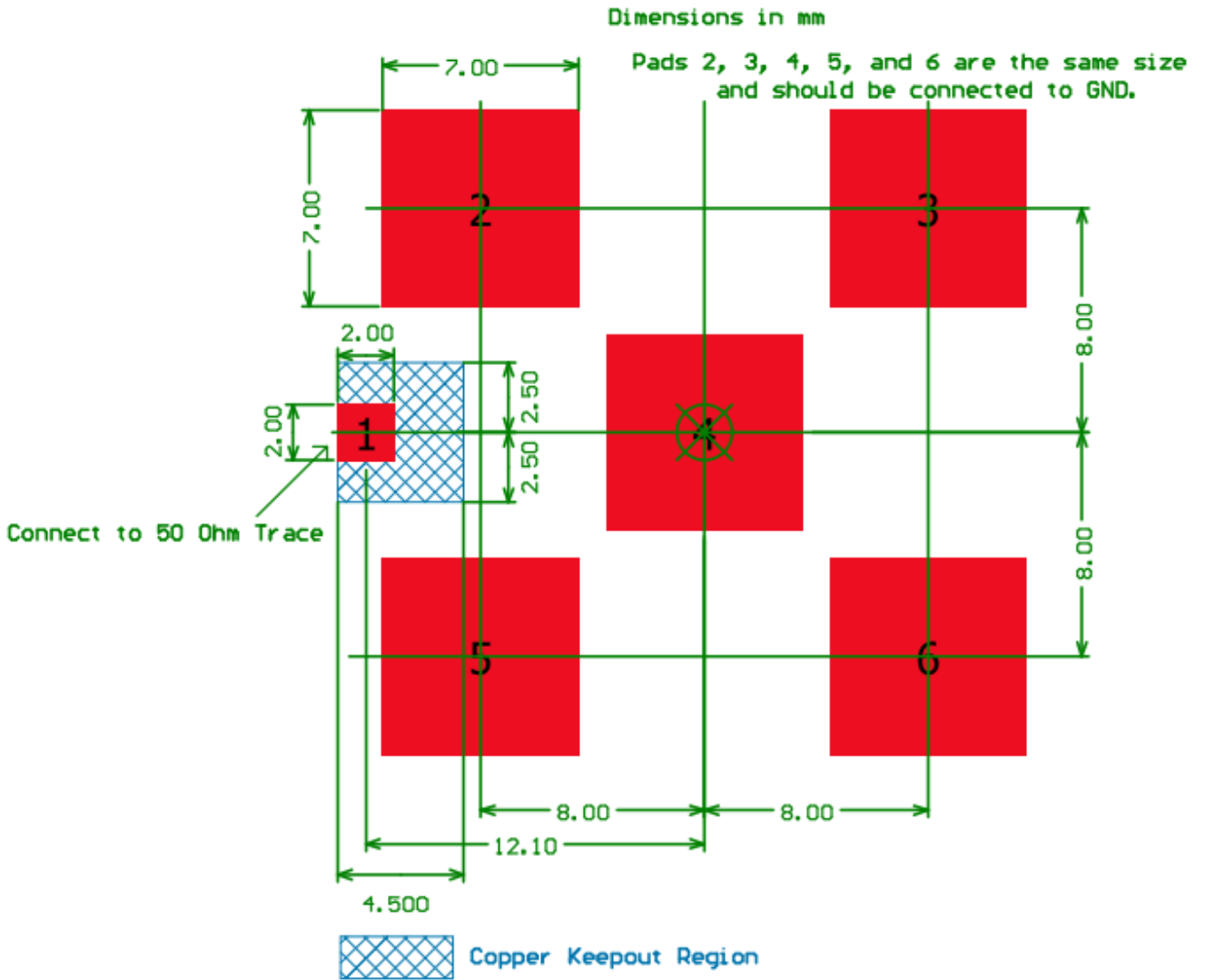

5.3. Paste Area

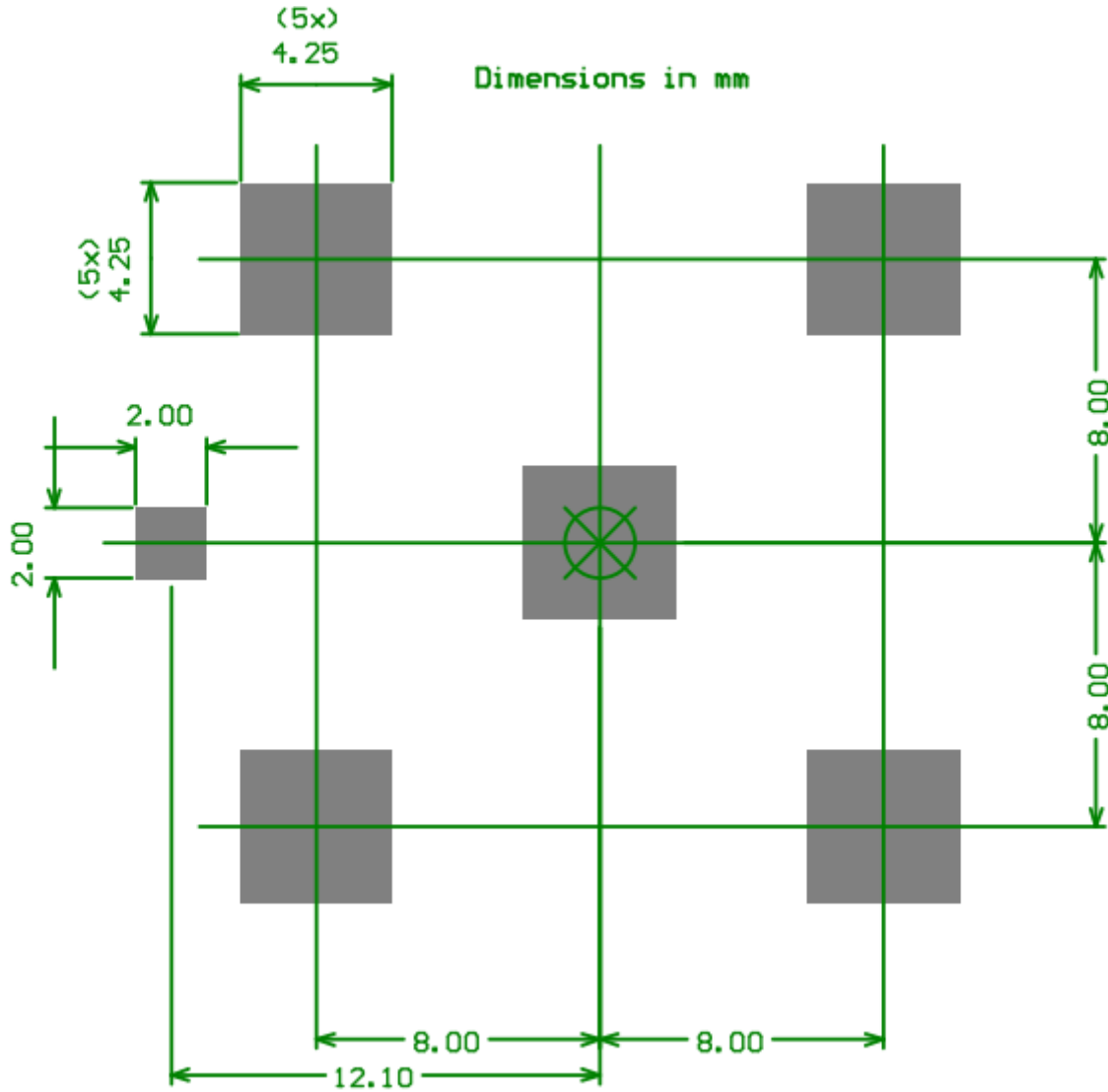

5.4. Soder Mask (Negative)

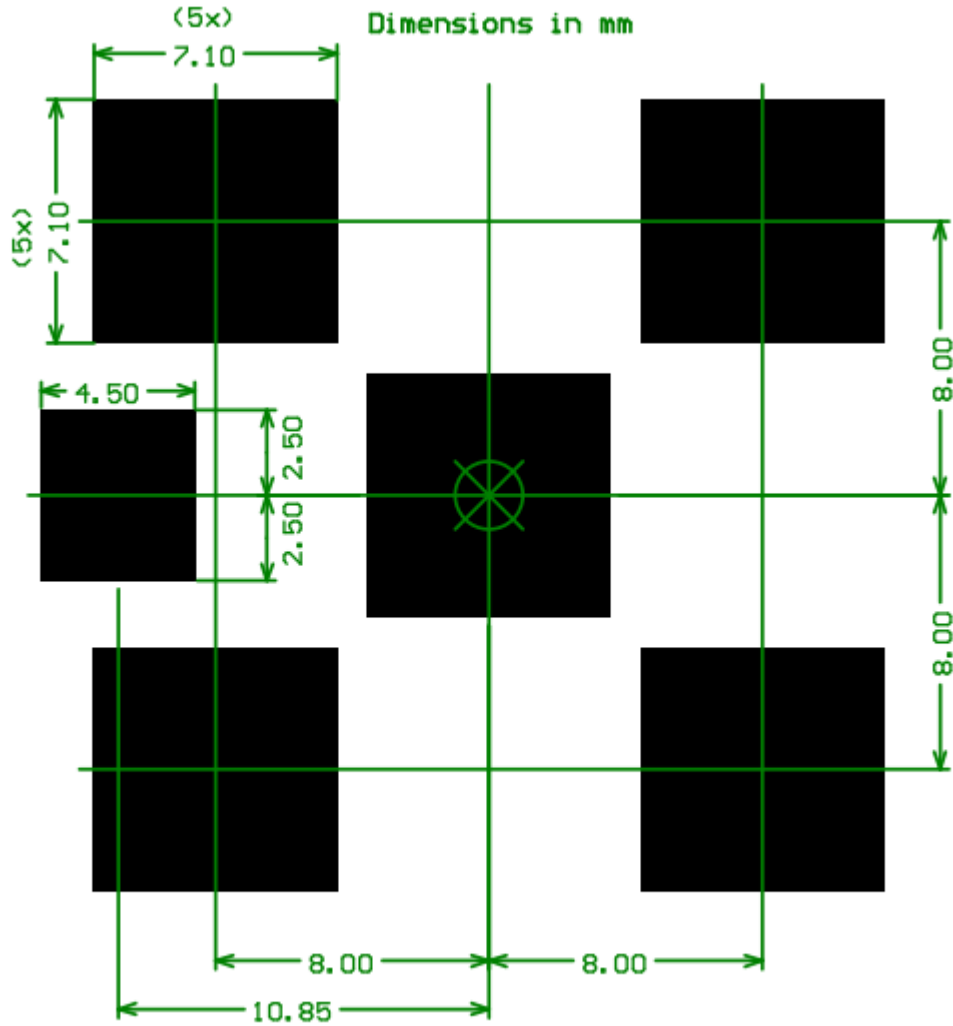

This drawing is a negative of solder mask.
Black regions are anti-mask.

5.5. Footprint Composite

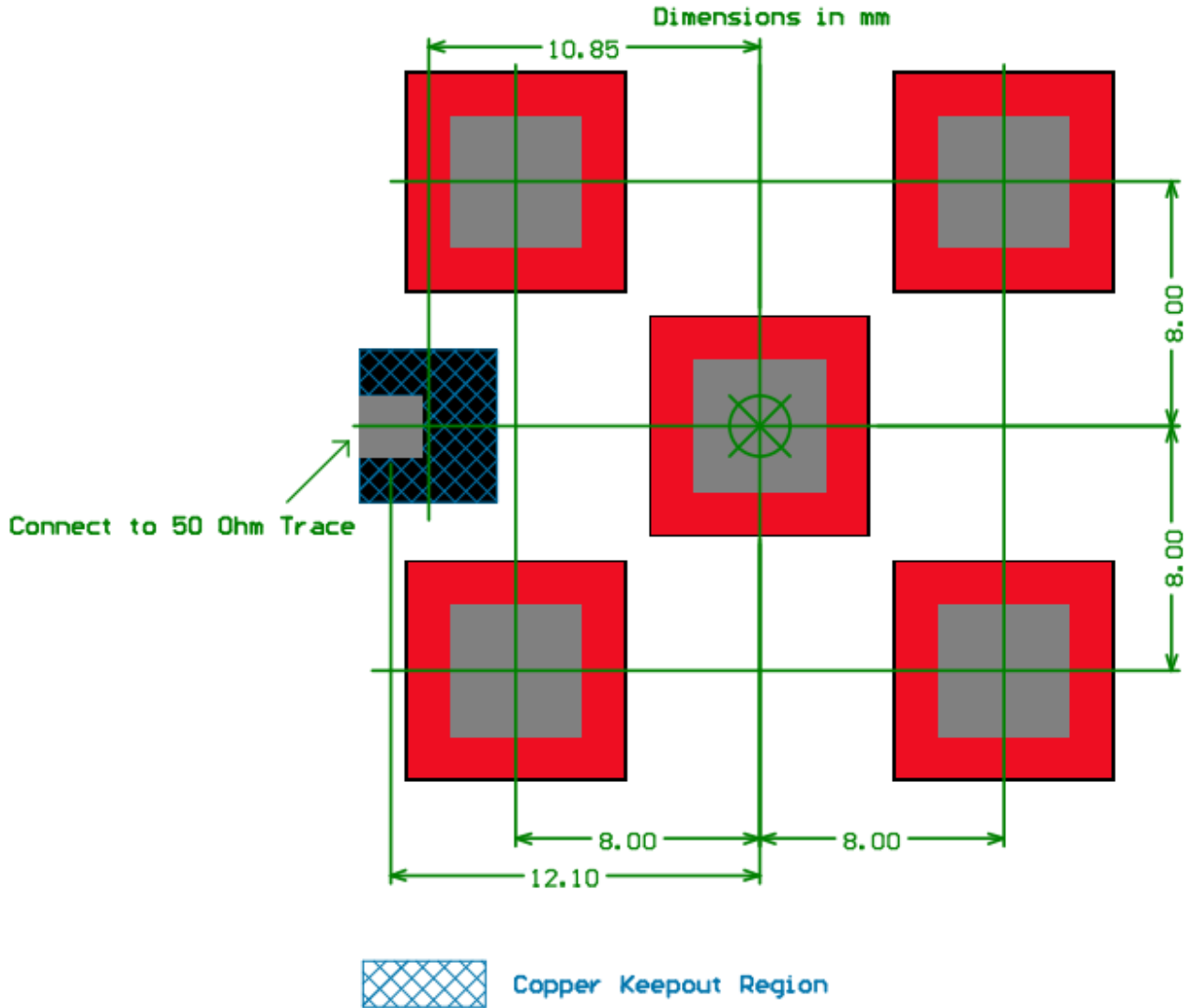

5.6. Test Jig and Dimension SGGPD.25A

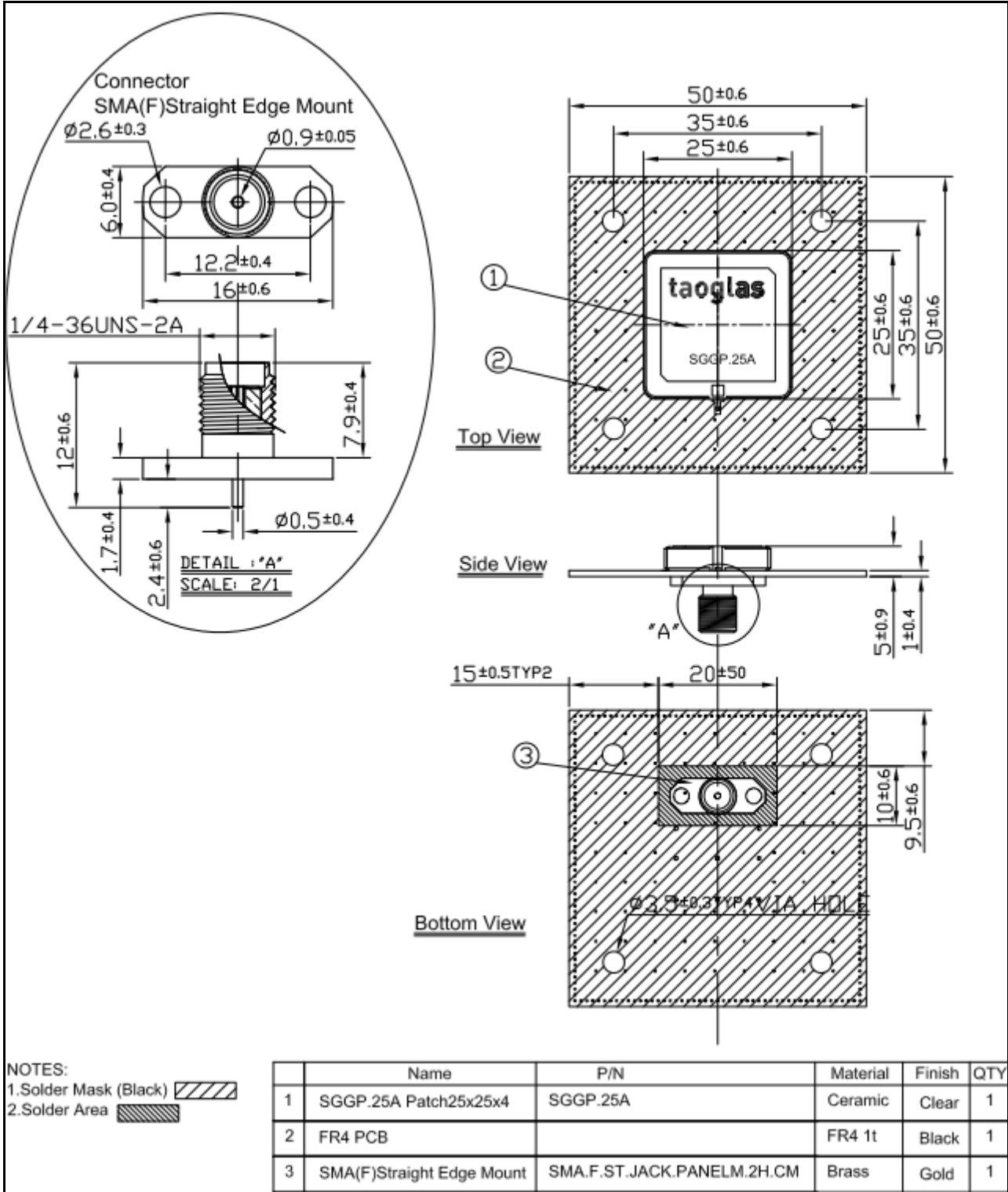

5.7. SGGPD.25A

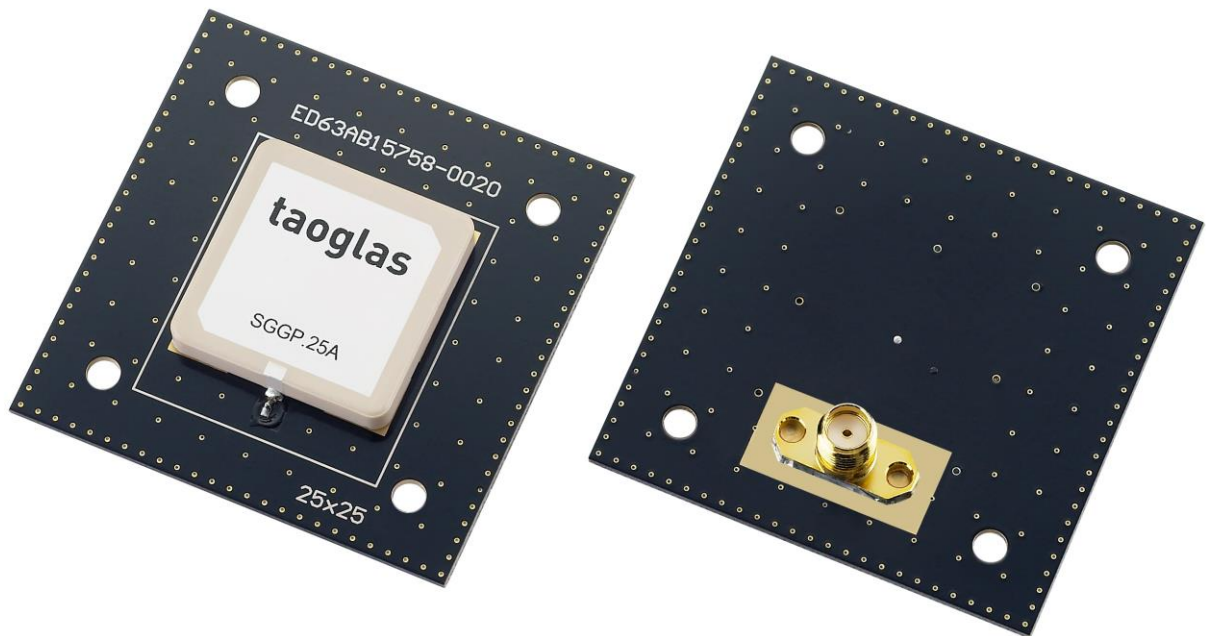

6. Recommended Reflow Soldering Profile

SGGP.25A can be assembled following Pb-free assembly. According to the Standard IPC/JEDEC J-STD-020C, the temperature profile suggested is as follow:

Phase	Profile Features	Pb-Free Assembly (SnAgCu)
PREHEAT	Temperature Min(T_{smin})	150°C
	Temperature Max(T_{smax})	200°C
	Time(t_s) from (T_{smin} to T_{smax})	60-120 seconds
RAMP-UP	Avg. Ramp-up Rate (T_{smax} to TP)	3°C/second(max)
REFLOW	Temperature(T_L)	217°C
	Total Time above T_L (t_L)	30-100 seconds
PEAK	Temperature(T_P)	260°C
	Time(t_p)	2-5 seconds
RAMP-DOWN	Rate	3°C/second(max)
Time from 25°C to Peak Temperature		8 minutes max.
Composition of solder paste		96.5Sn/3Ag/0.5Cu
Solder Paste Model		SHENMAO PF606-P26

The graphic shows temperature profile for component assembly process in reflow ovens

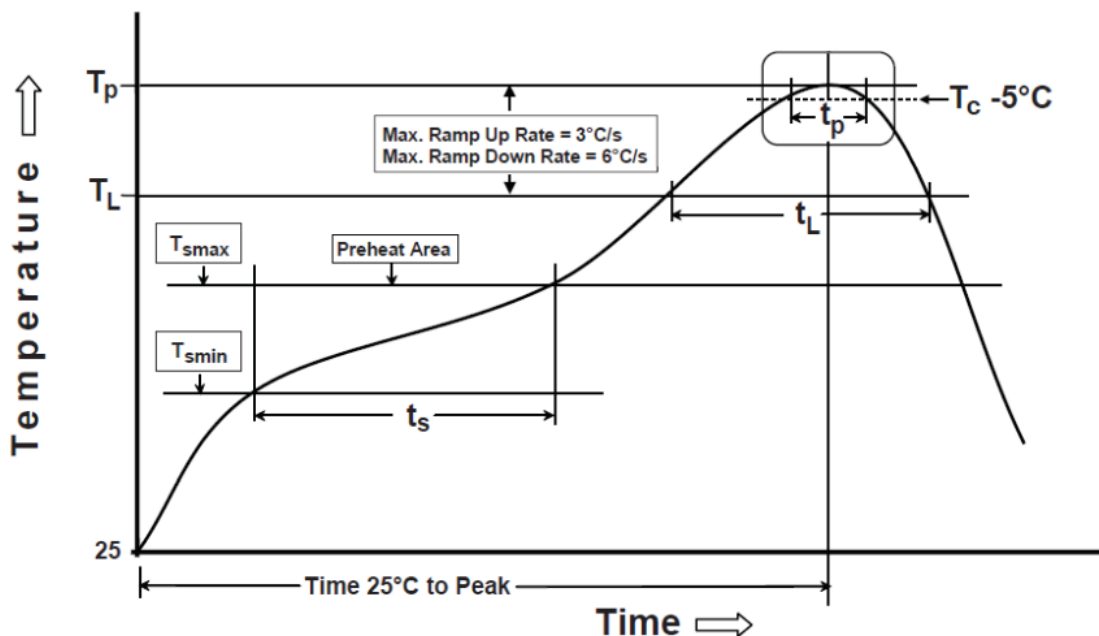

Soldering Iron condition: Soldering iron temperature $270^\circ\text{C} \pm 10^\circ\text{C}$.

Apply preheating at 120°C for 2-3 minutes. Finish soldering for each terminal within 3 seconds, if soldering iron temperature over $270^\circ\text{C} \pm 10^\circ\text{C}$ or 3 seconds, it will make cause component surface peeling or damage.

7. Packaging

200 pcs / reel / inner carton
 4 reels in an outer carton (800)

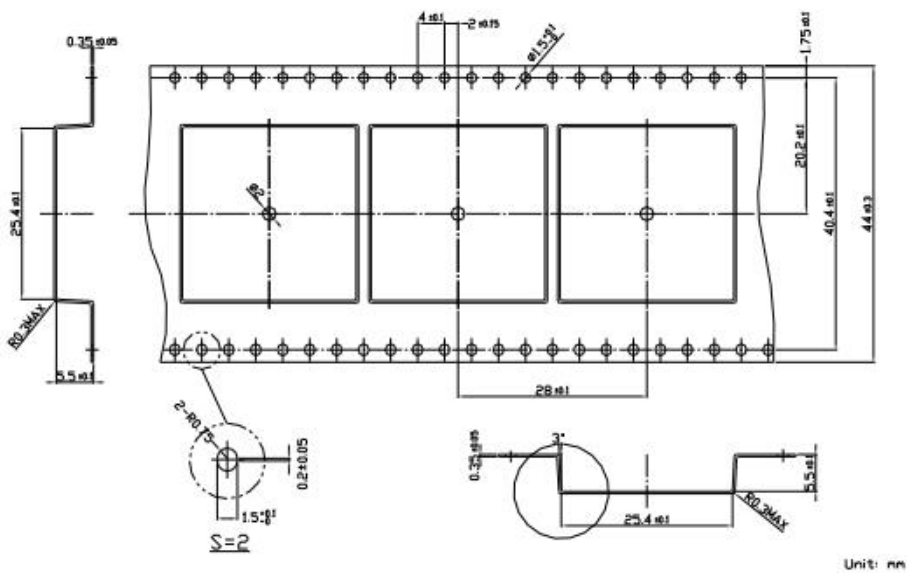
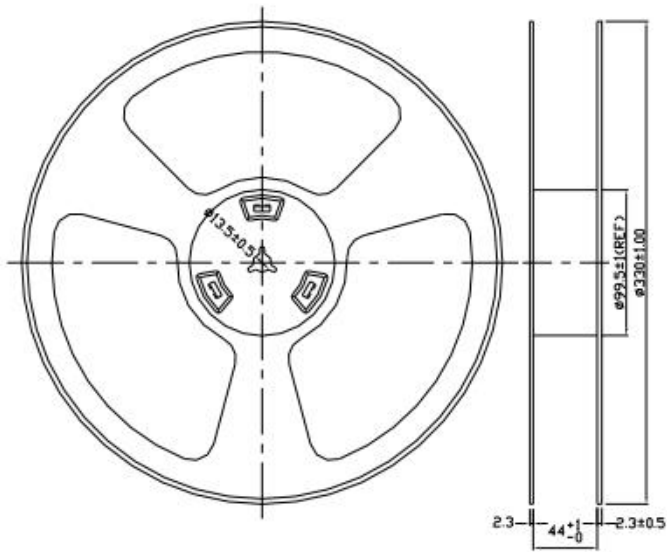

Taoglas makes no warranties based on the accuracy or completeness of the contents of this document and reserves the right to make changes to specifications and product descriptions at any time without notice. Taoglas reserves all rights to this document and the information contained herein.

Reproduction, use or disclosure to third parties without express permission is strictly prohibited.

Copyright © Taoglas Ltd.