

HYBRID - HIGH RELIABILITY RADIATION HARDENED DC-DC CONVERTER

LS-SERIES 28V Input, Single/Dual Output

Description

The LS-Series of DC-DC converters are, high reliability devices designed for hostile radiation hardened environments. The LS-Series provide up to 30 watts output power, small size, low weight, integrated EMI filtering and a high tolerance to environmental stresses such as radiation, temperature extremes, mechanical shock, and vibration. Extensive documentation including, thermal analysis, stress analysis and reliability predictions are available.

The LS-Series of converters incorporate a fixed frequency single forward topology with magnetic feedback and an internal EMI filter. These converters are capable of meeting the conducted emissions requirements of MIL-STD-461C without any additional components. All models include an external inhibit port and have an adjustable output voltage. They are enclosed in a hermetic 1.5" x 2.3" x 0.425" steel package and weigh less than 80 grams. The package utilizes rugged ceramic feed-through copper core pins and is sealed using parallel seam welding.

The LS-Series of DC-DC converters provide same mechanical outline, power ratings, for backward pin compatibility, to their lower radiation tolerant counterpart M3L and Military series ATS DC-DC converters. The common platform design allows for similarity between military and space system architectures. For higher output power applications the HM, M3H and M3G-Series of DC-DC converters are recommended.

Manufactured in a facility fully qualified to MIL-PRF-38534, these converters are fabricated utilizing DLA Land and Maritime qualified processes. For available screening options, refer to device screening table in the data sheet.

Variations in electrical specifications and screening to meet custom requirements can be accommodated.

www.irf.com

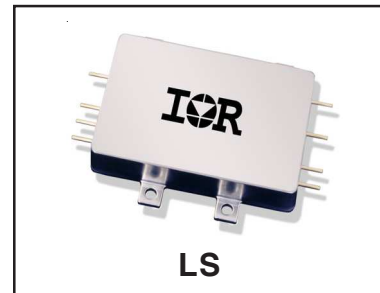

Features

- 18 to 40V DC Input Range
- Total Ionization Dose > 100K Rad(Si)
- SEE Hardened to LET (Heavy Ions) up to 82 MeV·cm²/mg (SEU, SEL, SEGB, SEGR)
- Internal EMI filter; Converter Capable of meeting MIL-STD-461C CE03
- Low Weight, < 80 grams
- Magnetically Coupled Feedback
- Up to 30W Output Power
- Single and Dual Output Models Include 1.5, 2.5, 3.3, 5, 12, 15, ±5, ±12 and ±15V
- High Efficiency - to 83%
- 100MΩ @ 500VDC Isolation
- Under-Voltage Protection
- Short Circuit and Overload Protection
- Adjustable Output Voltage
- External Inhibit
- > 4,000,000 Hour MTBF (SF)
- Standard Microcircuit Drawings Available

Applications

- Geo Synchronous Satellite
- Low Earth Orbit
- Deep Space Probe
- Communication and Display Systems
- Payload and Experiment LVPS

LS-SERIES (28V Input, Single/Dual Output)

International
IR Rectifier

Circuit Description

The LS-Series converters utilize a single-ended forward topology with resonant reset. The nominal switching frequency is 500kHz. Electrical isolation and tight output regulation are achieved through the use of a magnetically coupled feedback. Voltage feed-forward with duty factor limiting provides high line rejection and protection against output over voltage in the event of an internal control loop failure.

An internal EMI filter allows the converter to meet the conducted emissions requirements of MIL-STD-461C on the input power leads.

Output current is limited under any load fault condition to approximately 125% of rated. An overload condition causes the converter output voltage to drop below nominal. The converter will resume normal operation when the load current is reduced below the current limit point. This protects the converter from both overload and short circuit conditions. The current limit point exhibits a slightly negative temperature coefficient to reduce the possibility of thermal runaway.

An external inhibit port is provided to control converter operation. The converter's operation is inhibited when this pin is pulled low. It is intended to be driven by an open collector logic device. The pin may be left open for normal operation and has a nominal open circuit voltage of 11V with respect to the input return (pin 2).

The output voltage of all models can be adjusted using a single external resistor.

Design Methodology

The LS-Series was developed using a proven conservative design methodology derived from other space level designs that includes selection of established reliability components and fully de-rating to the requirements of MIL-STD-975 except for the CDR type of capacitors, a capacitor with 50V rating is used for in-circuit voltage stress of less than 10V. A magnetic feedback circuit is utilized instead of opto-couplers to minimize temperature, aging and radiation sensitivity. PSpice was used extensively to predict and optimize circuit performance for both beginning and end-of-life. Thorough design analyses include stress, thermal, and reliability (MTBF).

Absolute Maximum Ratings		Recommended Operating Conditions	
Input voltage range	-0.5Vdc to +60Vdc	Input voltage range ¹	+18Vdc to +40Vdc
Output power	Internally limited	Output power	0 to Max. Rated
Lead temperature	+300°C for 10 seconds	Operating case temperature	-55°C to +85°C
Operating case temperature	-55°C to +125°C (Note 13)	Operating case temperature ²	-55°C to +70°C
Storage temperature	-55°C to +135°C		

1. Input voltage rating is BOL. Input voltage range reduced to 20 to 40VDC for EOL.
2. Meets de-rating per MIL-STD-975

Electrical Performance Characteristics

Parameter	Group A Subgroup	Conditions -55°C ≤ T _C ≤ +85°C V _{IN} = 28V DC ± 5%, C _L = 0 unless otherwise specified	Limits			Unit		
			Min	Nom	Max			
Input Voltage			18	28	40	V		
Output Voltage (V _{OUT})								
LS2801R5S	1	I _{OUT} = 100% rated load	1.47	1.50	1.53	V		
LS2802R5S	1	Note 4	2.47	2.50	2.53			
LS2803R3S	1		3.27	3.30	3.33			
LS2805S	1		4.95	5.00	5.05			
LS2812S	1		11.88	12.00	12.12			
LS2815S	1		14.85	15.00	15.15			
LS2805D	1		±4.95	±5.00	±5.05			
LS2812D	1		±11.88	±12.00	±12.12			
LS2815D	1		±14.85	±15.00	±15.15			
LS2801R5S	2,3	I _{OUT} = 100% rated load	1.43		1.57		V	
LS2802R5S	2,3	Notes 4, 14	2.43		2.57			
LS2803R3S	2,3		3.23		3.37			
LS2805S	2,3		4.90		5.10			
LS2812S	2,3		11.76		12.24			
LS2815S	2,3		14.70		15.30			
LS2805D	2,3		±4.90		±5.10			
LS2812D	2,3		±11.76		±12.24			
LS2815D	2,3		±14.70		±15.30			
Output power (P _{OUT})								
LS2801R5S	1,2,3	V _{IN} = 18, 28, 40 Volts, Note 2	0		12	W		
LS2802R5S			0		20			
LS2803R3S			0		25			
All Others			0		30			
Output current (I _{OUT})								
LS2801R5S	1,2,3	V _{IN} = 18, 28, 40 Volts, Note 2	0		8.0	A		
LS2802R5S			0		8.0			
LS2803R3S			0		7.57			
LS2805S			0		6.0			
LS2812S			0		2.5			
LS2815S			0		2.0			
LS2805D			Either Output, Note 3	0			4.8	
LS2812D			Either Output, Note 3	0			2.3	
LS2815D			Either Output, Note 3	0			1.6	
Line regulation (V _{RLINE})		1,2,3	V _{IN} = 18, 28, 40 Volts I _{OUT} = 0, 50%, 100% rated, Note 4	-0.5			0.5	%
Load regulation (V _{RLOAD})		1,2,3	V _{IN} = 18, 28, 40 Volts I _{OUT} = 0, 50%, 100% rated, Note 4	-2.0			2.0	%
LS2801R5S				-1.2			1.2	
All others				-1.0			1.0	
Cross regulation (V _{RCROSS})	1,2,3	V _{IN} = 18, 28, 40 Volts Duals only, Note 5	-5.0		5.0	%		
LS2805D			-3.0		3.0			
LS2812D			-3.0		3.0			
LS2815D			-3.0		3.0			

For Notes to Electrical Performance Characteristics, refer to page 5

Electrical Performance Characteristics (continued)

Parameter	Group A Subgroup	Conditions -55°C ≤ T _C ≤ +85°C V _{IN} = 28V DC ± 5%, C _L = 0 unless otherwise specified	Limits			Unit
			Min	Nom	Max	
Input Current, no load (I _{IN}) LS2801R5S LS2802R5S LS2803R3S LS2805S LS2812S LS2815S LS2805D LS2812D LS2815D	1,2,3	I _{OUT} = 0, Pin 4 open			60 60 60 70 70 70 70 100 100	mA
Input current inhibited	1,2,3	Pin 4 shorted to pin 2			8.0	mA
Output Ripple, (V _{RIP}) LS2801R5S LS2802R5S LS2803R3S LS2805S LS2812S LS2815S LS2805D LS2812D LS2815D	1,2,3	V _{IN} = 18, 28, 40 Volts I _{OUT} = 100% rated load Notes 4, 6			35 35 35 50 70 80 80 80 80	mV p-p
Switching frequency (F _S)	1,2,3		425	500	575	KHz
Efficiency (E _{FF}) LS2801R5S LS2802R5S LS2803R3S LS2805S LS2812S LS2815S LS2805D LS2812D LS2815D	1,2,3	I _{OUT} = 100% rated load Note 4	61 68 72 78 78 78 79 79	64 72 76 82 82 82 83 83		%
Enable Input (Inhibit Function) open circuit voltage drive current (sink) voltage range		Note 1	9.5 -0.5		12 5.0 50	V mA V
Current Limit Point Expressed as a percentage of full rated load current	1,2,3	V _{OUT} = 90% of Nominal, Note 4	105		145	%
Power dissipation, load fault (P _D)	1,2,3	Short Circuit, Overload, Note 8			14	W
Output response to step load changes (V _{TLD})	4,5,6	Half Load to/from Full Load, Notes 4,9	-300		300	mV pk
Recovery time, step load changes (T _{TLD})	4,5,6	Half Load to/from Full Load, Note 4,9,10			200	μs
Output response to step line changes (V _{TLN})		18V to/from 40V I _{OUT} = 100% rated load, Notes 1,4,11	-300		300	mV pk
Recovery Time, step line changes (T _{TLN})		18V to/from 40V I _{OUT} = 100% rated load, Notes 1,4,10,11			200	μs

For Notes to Electrical Performance Characteristics, refer to page 5

Electrical Performance Characteristics (continued)

Parameter	Group A Subgroup	Conditions -55°C ≤ T _c ≤ +85°C V _{IN} = 28V DC ± 5%, C _L = 0 unless otherwise specified	Limits			Unit
			Min	Nom	Max	
Turn-on Overshoot (V _{OS}) LS2801R5S LS2802R5S LS2803R3S LS2805S LS2812S LS2815S LS2805D LS2812D LS2815D Turn-on Delay (T _{DLY})	4,5,6	10% Load, Full Load Notes 4,12			150 250 330 500 1000 1000 500 1000 1000	mV
			0		10	ms
Capacitive Load (CL) LS2801R5S LS2802R5S LS2803R3S LS2805S LS2812S LS2815S LS2805D LS2812D LS2815D		I _{OUT} = 100% rated load No effect on DC performance Notes 1, 4, 7 Each output on duals			2500 2500 2200 1000 180 120 500 90 60	μF
Line Rejection	1	I _{OUT} = 100% rated load DC to 50KHz, Notes 1, 4	35	50		dB
Isolation	1	Input to Output or Any Pin to Case except pin 3, test @ 500VDC	100			MΩ
Device Weight					80	g
MTBF		MIL-HDBK-217F2, SF, 35°C	4.0 x 10 ⁶			Hr

Notes for Electrical Performance Characteristics Table

- Parameter is tested as part of design characterization or after design changes. Thereafter, parameter shall be guaranteed to the limits specified.
- Parameter verified during line and load regulation tests.
- Output load current must be distributed such that at least 20% of the total load current is being provided by one of the outputs.
- Load current split equally between outputs on dual output models.
- Cross regulation is measured with 20% rated load on output under test while changing the load on the other output from 20% to 80% of rated.
- Guaranteed for a D.C. to 20MHz bandwidth. Tested using a 20KHz to 10MHz bandwidth using the circuit on page 6.
- Capacitive load may be any value from 0 to the maximum limit without compromising dc performance. For a capacitive load in excess of the maximum limit, consult the factory.
- Overload power dissipation is defined as the device power dissipation with the load set such that V_{OUT} = 90% of nominal.
- Load step transition time ≤ 10μs.
- Recovery time is measured from the initiation of the transient to where V_{OUT} has returned to within ±1% of its steady state value.
- Line step transition time ≤ 100μs.
- Turn-on delay time from either a step application of input power or a logic low to a logic high transition on the inhibit pin (pin 4) to the point where V_{OUT} = 90% of nominal.
- For operation at temperatures between +85°C and 125°C, de-rate the maximum output power linearly from 100% to 75%.
- End of life (EOL) is ±3%

LS-SERIES
(28V Input, Single/Dual Output)

International
IR Rectifier

Circuit for Measuring Output Ripple Voltage

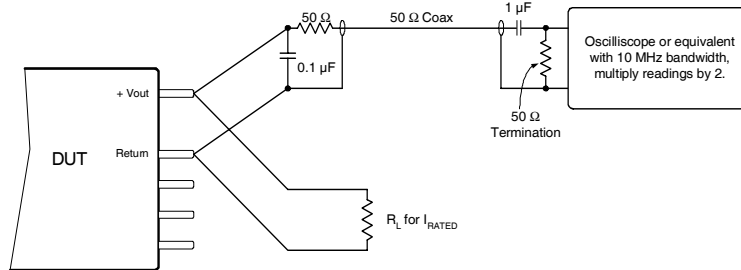

Radiation Performance Characteristics

Test	Conditions	Min	Typ	Unit
Total Ionizing Dose (Gamma)	MIL-PRF-883, Method 1019.5 Operating bias applied during exposure, Half Rated Load, $V_{IN} = 28V$	100		Krads(Si)
Single Event Effects SEU, SEL, SEGR, SEB	Heavy Ions (LET) Operating bias applied during exposure, Full Rated Load, $V_{IN} = 18V, 28V \text{ \& } 40V$ Test lab: Cyclotron Institute, Texas A & M University	82		$MeV \cdot cm^2/mg$

International Rectifier currently does not have a DLA Land and Maritime certified Radiation Hardness Assurance Program.

LS Series Output Voltage Adjustment

Output of LS series can be adjusted to be greater or less than the nominal output voltage with an external resistor. However, the ranges of the output voltages are limited depending on the model as specified in Table 1 and 2. An approximate value of the resistor can be determined using the following formula.

$$\text{For Single Output Model: } R_{adj} = \frac{A - (B \times V_{out})}{(C \times V_{out}) - D}$$

$$\text{For Dual Output Model: } R_{adj} = \frac{A - (B \times 2V_{out})}{(C \times 2V_{out}) - D}$$

Where:

R_{adj} is the value of the external resistor in kilo-ohms, R_{down} or R_{up} in Figure 1 or 2. Power rating of the resistor shall be $\geq 0.125W$. Metal film resistor with temperature coefficient of $\leq \pm 50$ ppm and tolerance of $\leq 1\%$ is recommended. However, the final selection is dependent on specific design requirements.

V_{out} is the desired output voltage in volts.

A, B, C, and D are unique constants depending on the model as shown in Table 1 for single output models and Table 2 for dual output models.

Table 1: Single Output Voltage Ranges and Constants

Model	Output Voltage Range (V) (1)	A	B	C	D
LS2801R5S	1.500 to 1.600	69.65	32.39	8.75	13.13
	1.400 to 1.500	56.85	40.47	7.14	10.72
LS2802R5S	2.500 to 2.750	48.42	13.04	3.52	8.81
	2.250 to 2.500	39.52	21.19	2.88	7.19
LS2803R3S	3.300 to 3.630	43.48	9.25	2.50	8.25
	2.970 to 3.300	35.48	16.18	2.04	6.73
LS2805S	5.000 to 5.500	119.48	20.00	2.27	11.36
	4.500 to 5.000	97.52	29.31	1.85	9.27
LS2812S	12.000 to 13.200	295.22	19.98	2.27	27.24
	10.800 to 12.000	241.01	53.31	1.85	22.24
LS2815S	15.000 to 16.500	370.61	19.98	2.27	34.05
	13.500 to 15.000	302.55	63.61	1.85	27.80

Table 2: Dual Output Voltage Ranges and Constants

Model	Voltage Range of Each Output ($\pm V_{out}$) (1)	A	B	C	D
LS2805D	± 5.000 to ± 5.500	196.91	17.12	1.71	17.12
	± 4.500 to ± 5.000	160.74	31.11	1.40	13.97
LS2812D	± 12.000 to ± 13.200	475.43	17.05	1.71	40.92
	± 10.800 to ± 12.000	388.10	58.04	1.39	33.41
LS2815D	± 15.000 to ± 16.500	594.31	17.03	1.70	51.09
	± 13.500 to ± 15.000	485.10	69.47	1.39	41.70

Note:

(1). Also the minimum and maximum adjustment limits of the output voltage.

Placement of R_{adj}

An external resistor must be added in order to trim the output voltage of an LS converter. The placement of an R_{adj} resistor (R_{down} or R_{up}) must be as shown in Figure 1 for single output models and as per Figure 2 for dual output models. Please note that the connections are made to the specific pins. R_{up} is placed across Out Return and Out Adj pins for output voltage greater than nominal output. Similar connections apply for the dual output models.

Figure 1: Radj Placement for Single Output Model

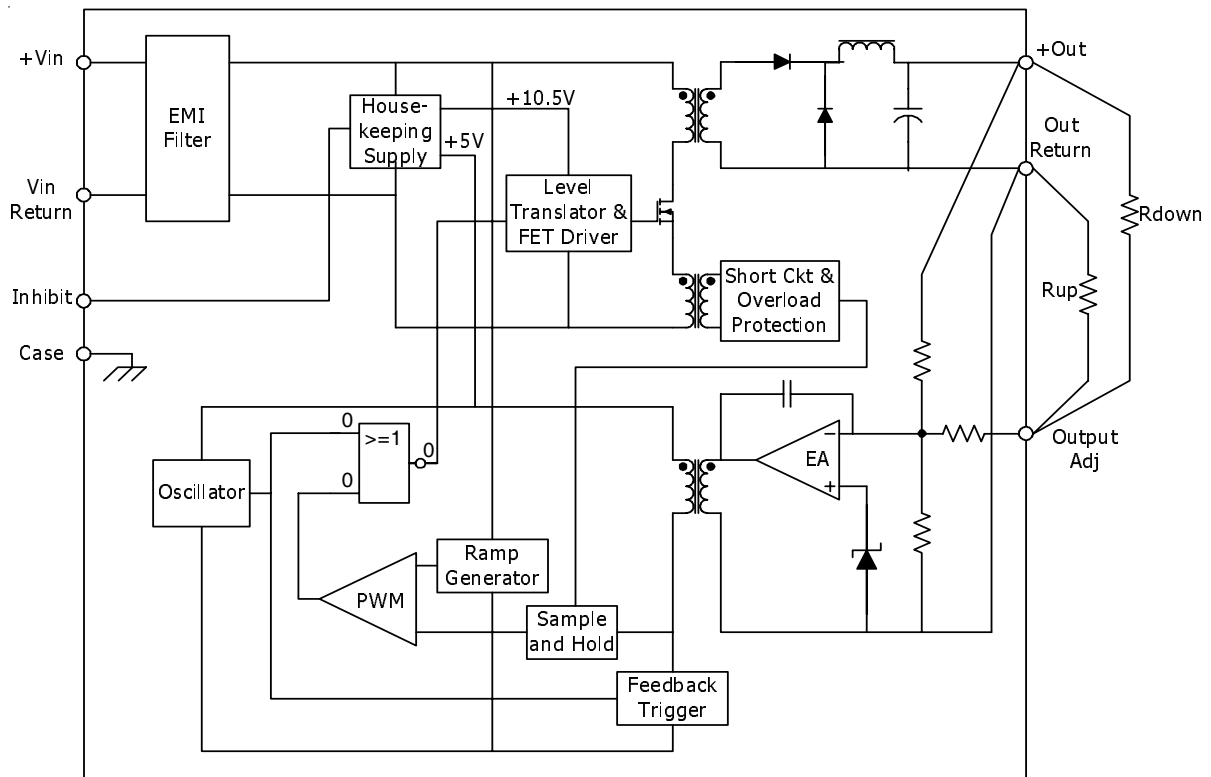
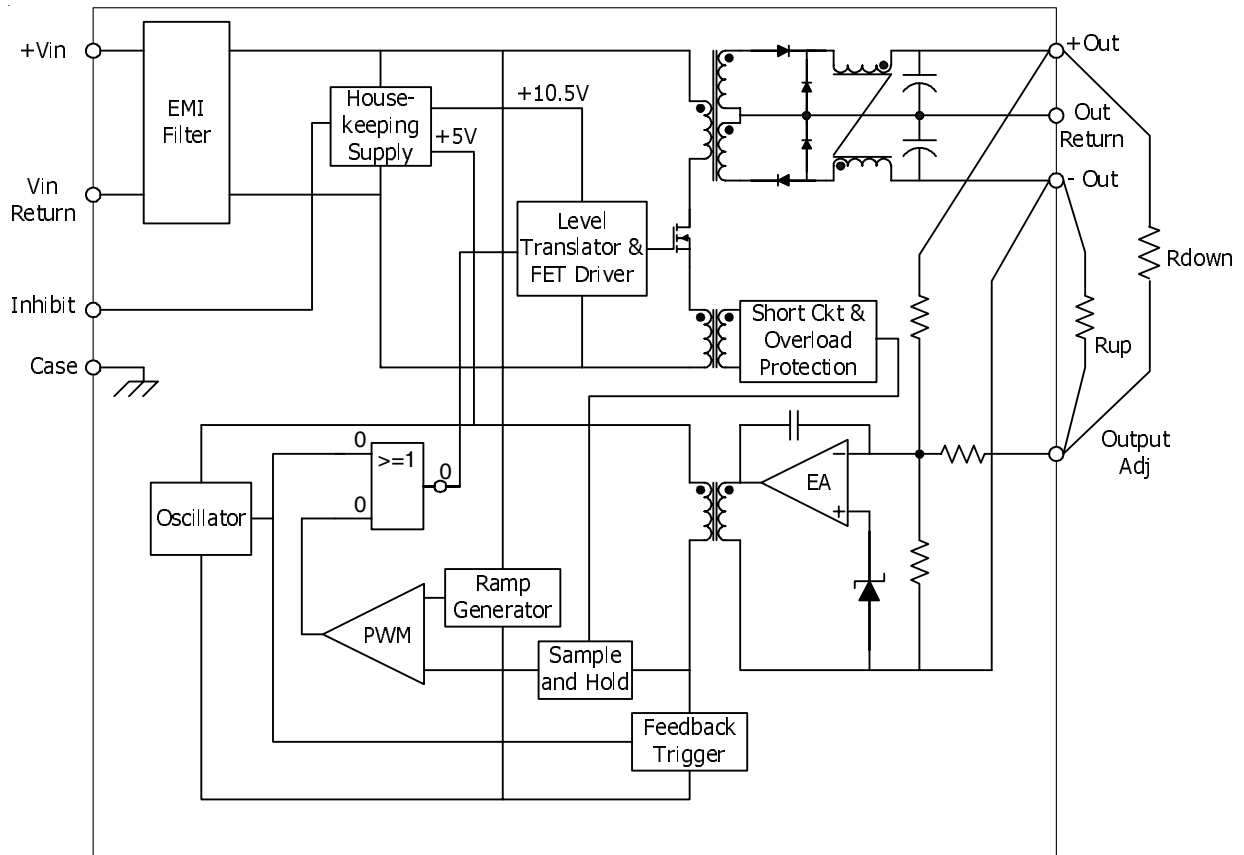
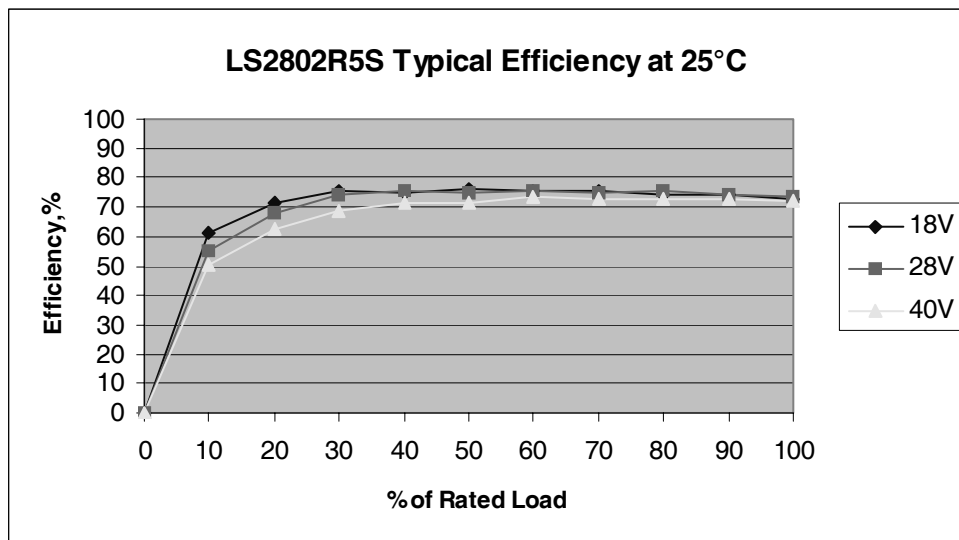
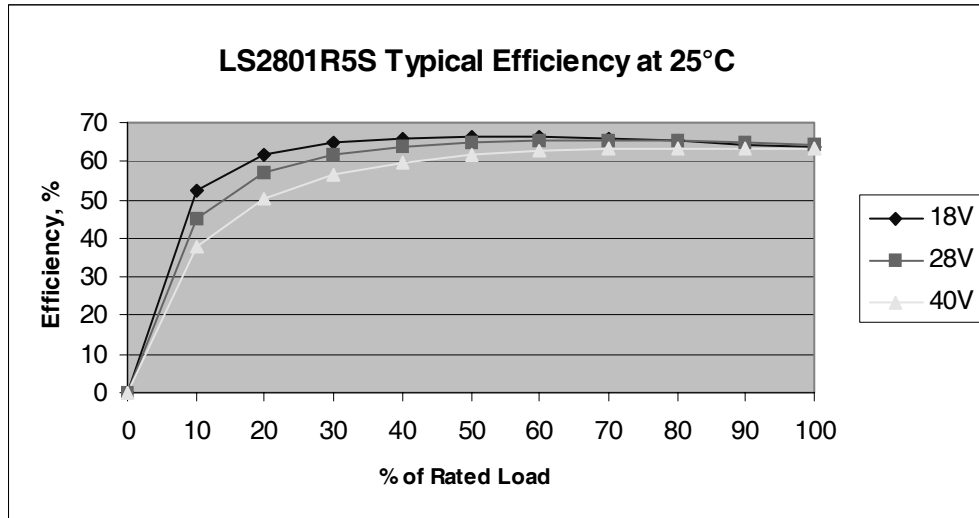
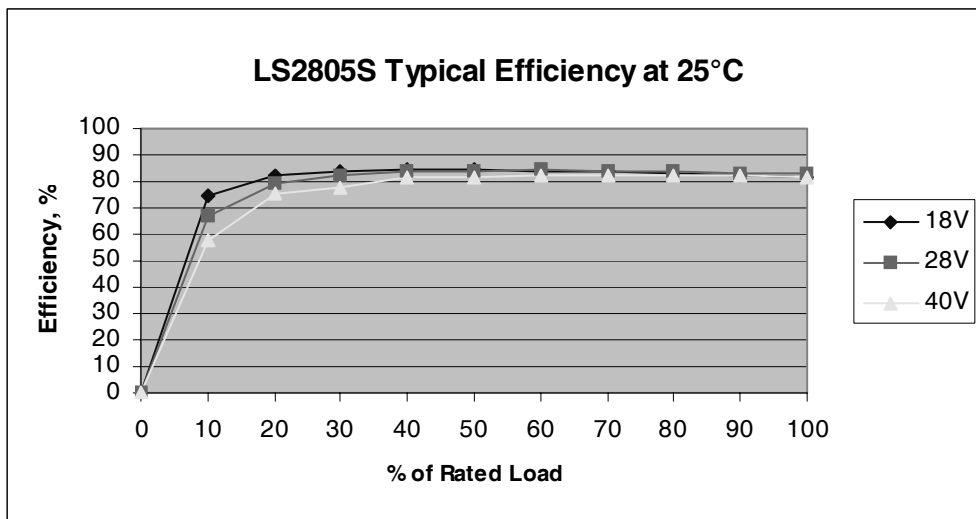
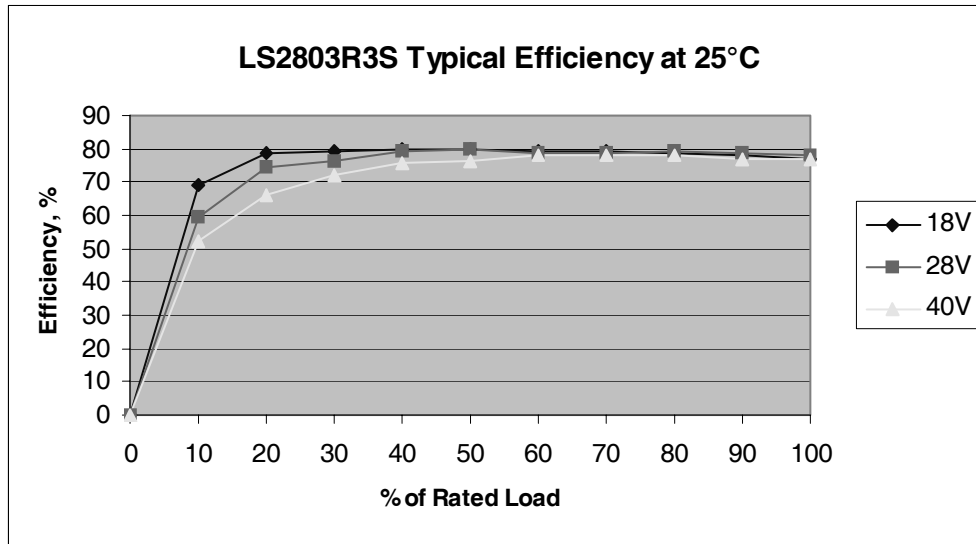
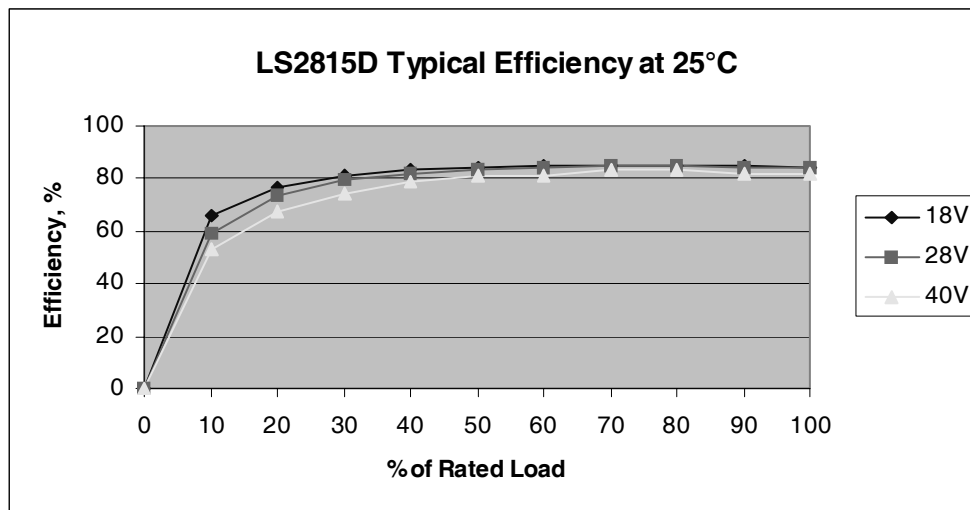
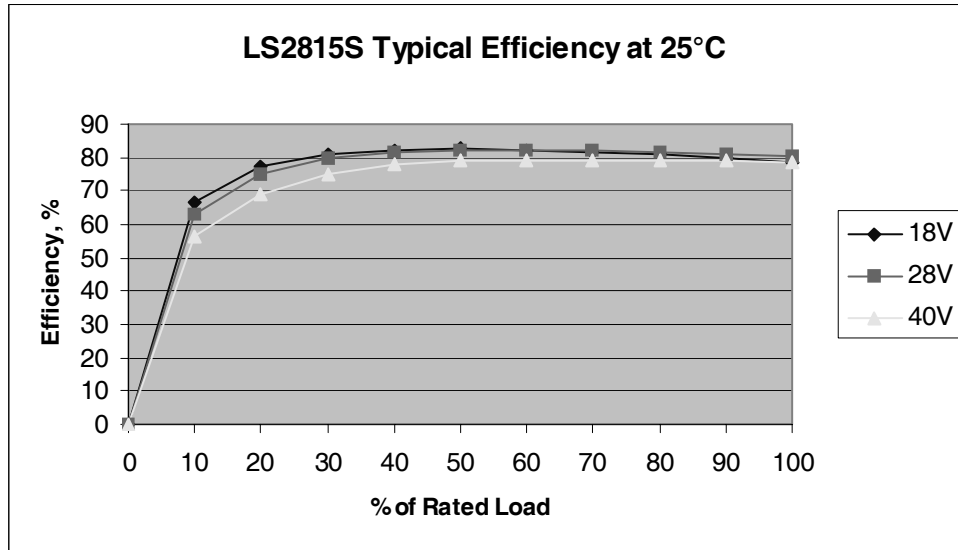

Figure 2: Radj Placement for Dual Output Model









LS-SERIES
(28V Input, Single/Dual Output)

International
IR Rectifier

Block Diagram - Single Output

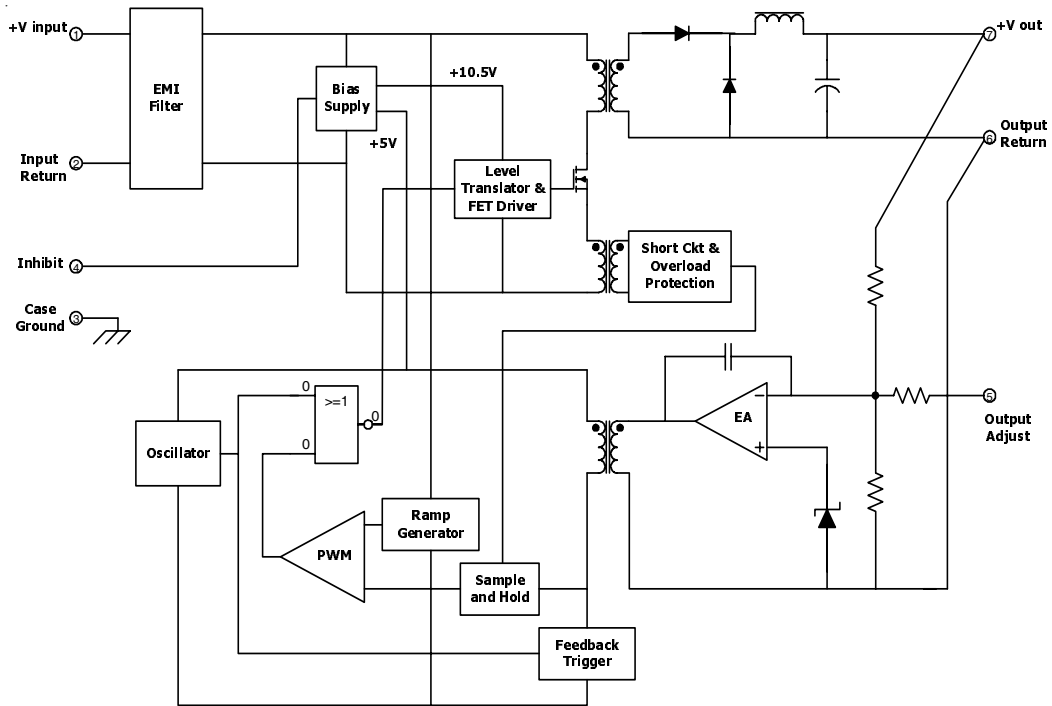

Block Diagram - Dual Output

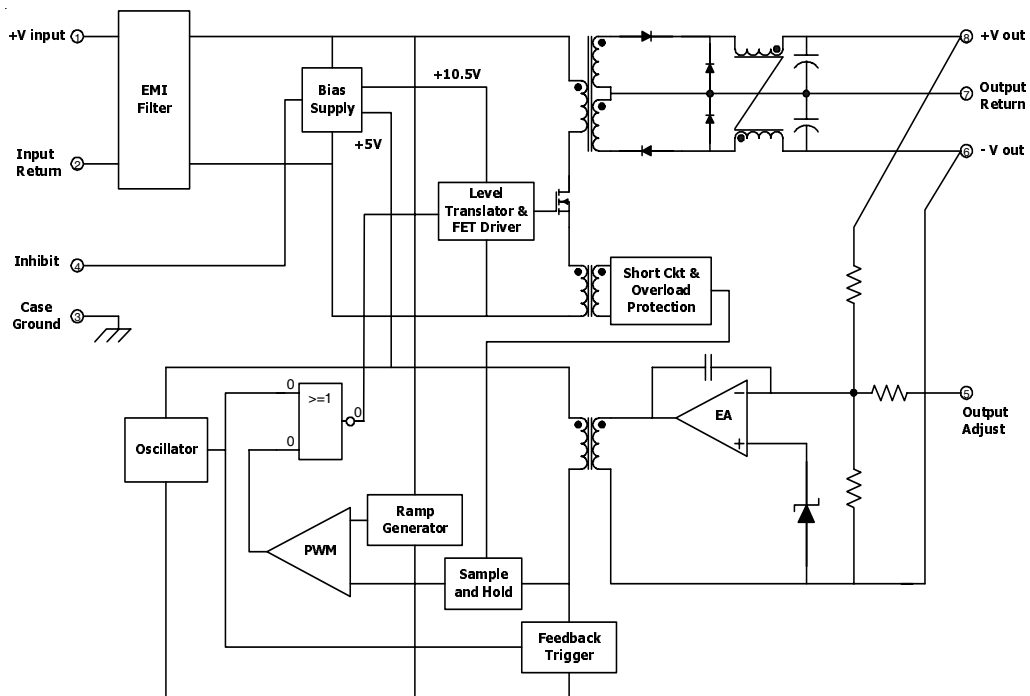

Mechanical Outline

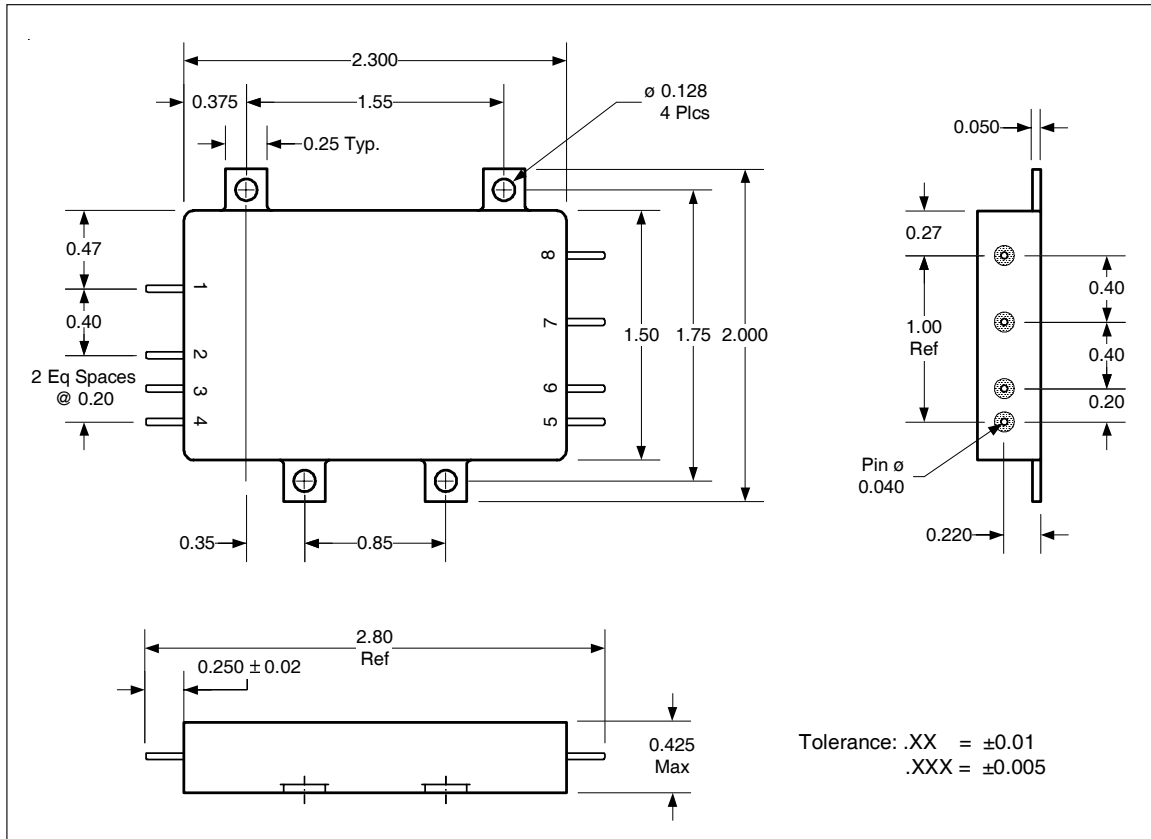

Pin Designation (Single/Dual)

Standard Microcircuit Drawing Equivalence Table

Pin #	Single	Dual
1	+ Input	+ Input
2	Input Return	Input Return
3	Case Ground	Case Ground
4	Inhibit	Inhibit
5	Output Adjust	Output Adjust
6	Output Return	- Output
7	+ Output	Output Return
8	NC	+ Output

Standard Microcircuit Drawing Number	IR Standard Part Number
5962-05238	LS2801R5S
5962-05239	LS2803R3S
5962-05240	LS2805S
5962-05241	LS2812D
5962-05242	LS2815D
5962-06241	LS2812S
5962-06242	LS2815S
5962-10224	LS2805D

LS-SERIES
(28V Input, Single/Dual Output)

International
IR Rectifier

Device Screening

Requirement	MIL-STD-883 Method	No Suffix ②	CK ②	EM
Temperature Range	—	-55°C to +85°C	-55°C to +85°C	-55°C to +85°C
Element Evaluation	MIL-PRF-38534	Class K	Class K	N/A
Non-Destructive Bond Pull	2023	Yes	Yes	N/A
Internal Visual	2017	Yes	Yes	①
Temperature Cycle	1010	Cond C	Cond C	Cond C
Constant Acceleration	2001, Y1 Axis	3000 Gs	3000 Gs	3000 Gs
PIND	2020	Cond A	Cond A	N/A
Burn-In	1015	320 hrs @ 125°C (2 x 160 hrs)	320 hrs @ 125°C (2 x 160 hrs)	48 hrs @ 125°C
Final Electrical (Group A)	MIL-PRF-38534 & Specification	-55°C, +25°C, +85°C	-55°C, +25°C, +85°C	-55°C, +25°C, +85°C
PDA	MIL-PRF-38534	2%	2%	N/A
Seal, Fine and Gross	1014	Cond A, C	Cond A, C	Cond A
Radiographic	2012	Yes	Yes	N/A
External Visual	2009	Yes	Yes	①

Notes:

- ① Best commercial practice.
- ② CK is a DLA Land and Maritime (formerly DSCC) part marking used to designate a Class K compliant hybrid.
The CK marking does not indicate the hybrid is radiation certified.
No Suffix is a radiation rated device but not available as a DLA Land and Maritime qualified SMD per MIL-PRF-38534.
International Rectifier currently does not have a DLA Land and Maritime certified Radiation Hardness Assurance Program.

Part Numbering

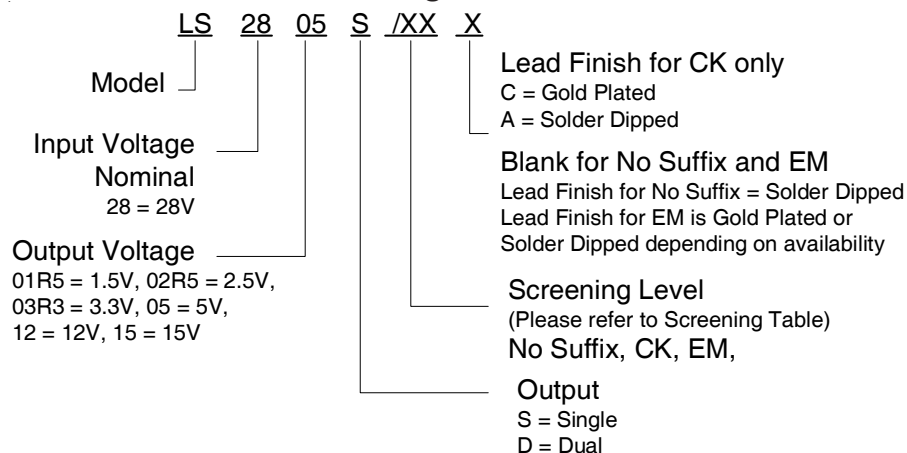

International
IR Rectifier

WORLD HEADQUARTERS: 233 Kansas St., El Segundo, California 90245, Tel: (310) 252-7105
IR SAN JOSE: 2520 Junction Avenue, San Jose, California 95134, Tel: (408) 434-5000
Visit us at www.irf.com for sales contact information.

Data and specifications subject to change without notice. 10/2012