

General Description

The MSI6000 is a level shifter IC with 11-channel intended for use in LCD Display application such as Note-book.

The device converts signal from logic-level generated by T-CON to the high voltage level used by the display panel.

6 channels Level shifter support gate voltage Shaping, which can be used to improve picture quality by reducing image sticking.

Application

- LCD Note-Book Panels

Features

- 11-Channel level shifter support 6 x GLK, VST, BRST, DSCH, DRST, and EVEN Signals
- VGH level up to 37.5V
- VGL Level down to -15V
- Panel DISCHARGE Function
- Suitable for 6-Phase Applications
- Gate Voltage Shaping on Channels 1 to 6 channels
- 24-Pin 4x4 mm QFN Package

Operational Diagram

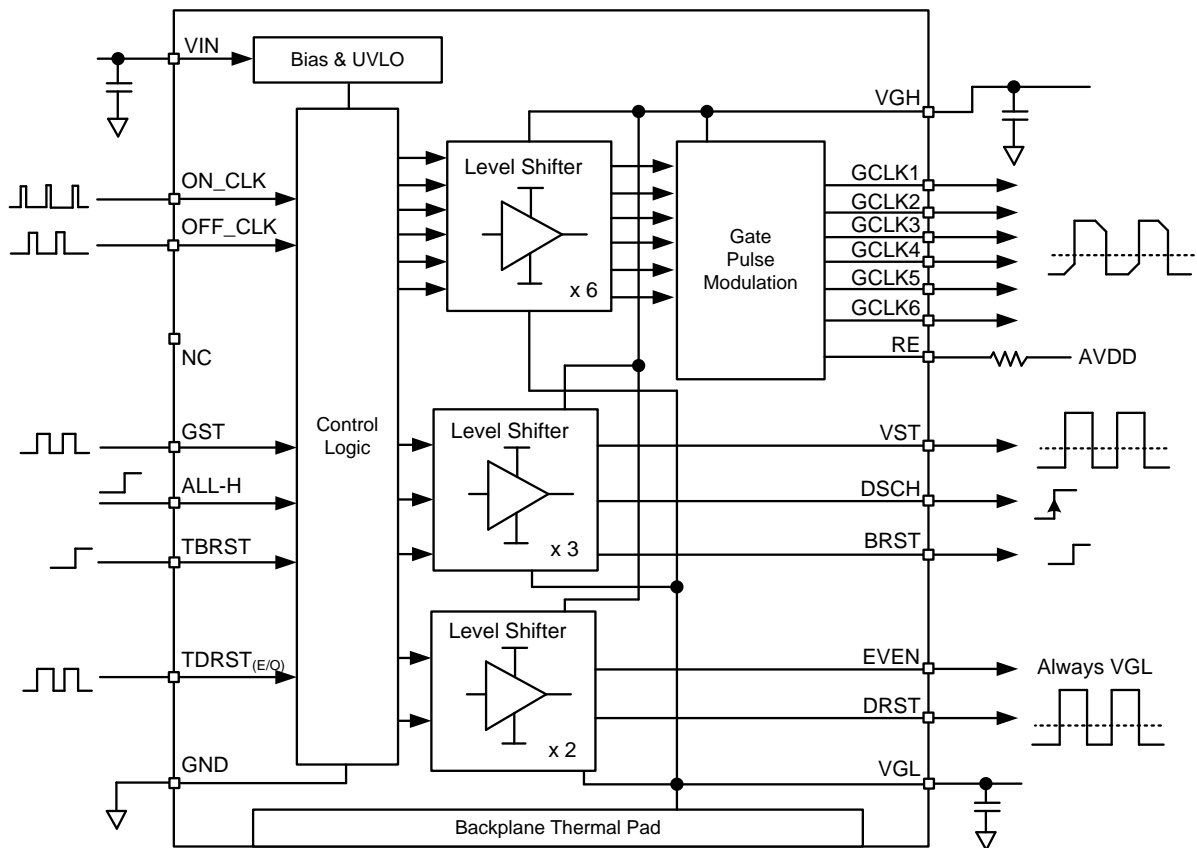
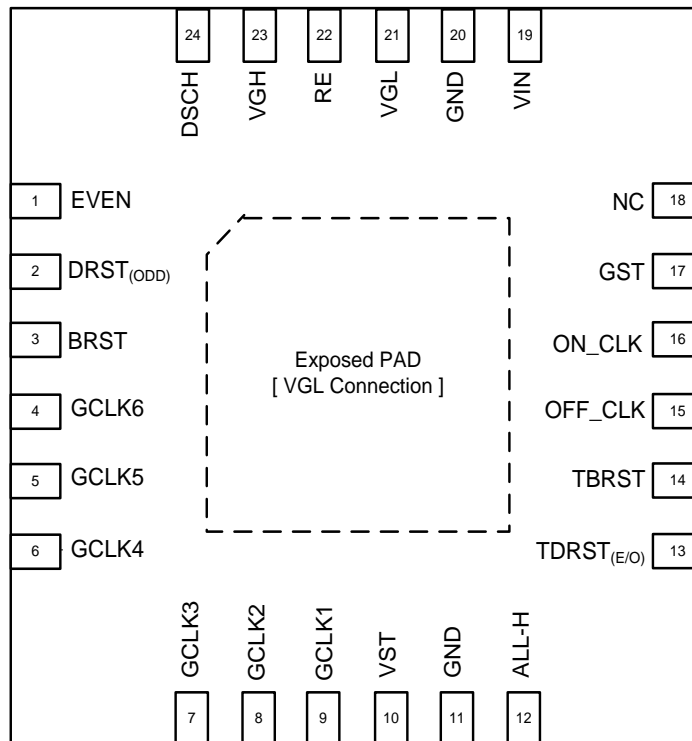

Figure 1) Block Diagram

Bill of Materials

item	Part Number	Manufacturer	Description	Qty.
IC	MSI6000	Magnachip	11 channel Level shifter	1
C _{IN}	CL10B105KO8NNNC	Samsung	1uF, 16V, 1608, X7R	1
C _{VGH/VGL}	CL21B105KBFNNNF	Samsung	1uF, 50V, 2012, X7R	2

Pin Configuration



Pin Definitions

Pin#	Name	IO	Description
1	EVEN	O	Level shifter Output , Always VGL Output Pin.
2	DRST(ODD)	O	Level shifter Output , High voltage level shifter output
3	BRST	O	Level shifter Output
4	GLK6	O	Level Shifter Outputs . High voltage level shifter outputs.
5	GLK5	O	Level Shifter Outputs . High voltage level shifter outputs.
6	GLK4	O	Level Shifter Outputs . High voltage level shifter outputs.
7	GLK3	O	Level Shifter Outputs . High voltage level shifter outputs.
8	GLK2	O	Level Shifter Outputs . High voltage level shifter outputs.
9	GLK1	O	Level Shifter Outputs . High voltage level shifter outputs.
10	VST	O	Level shifter Output for Vertical Start
11	GND	G	Level shifter Ground
12	ALL_H	I	Discharging Input
13	TDRST(E/O)	I	Level shifter Input for Gate DRST
14	TBRST	I	Level shifter Input BRST
15	OFF_CLK	I	Level shifter Input for GPM Start and GPM Duty , High voltage level shifter logic input
16	ON_CLK	I	Level shifter Input for GPM Start and GPM Duty , High voltage level shifter logic input
17	GST	I	Level shifter Input for Gate Start , Synchronized with VST
18	NC	I	Not Connected
19	VIN	P	VIN Input Supply Voltage
20	GND	G	Level shifter Ground
21	VGL	I	Negative Supply for Level Shifter . VGL supplies negative power to level shifter for Gate-Off. Place ceramic capacitor of sufficient capacity considering current level needed. Shunt capacitor to GND as close as possible to this pin.
22	RE	I	Gate High Output Fall Time and Gate Low Output rise time Setting pin . Connect a resistor to VDD to set the transition slope
23	VGH	I	Positive Supply for Level Shifter . VGH supplies positive power to ODD for Gate-On. Place ceramic capacitor of sufficient capacity considering current level needed. Shunt capacitor to GND as close as possible to this pin.
24	DSCH	O	Output for Discharge . Negated high voltage level-shifted output
N/A	E-PAD	G	Connect VGL

Absolute Maximum Ratings

Absolute Maximum ratings [$T_A=25^{\circ}\text{C}$, Unless otherwise noted]

Parameter	Value	Unit
ON_CLK, OFF_CLK, GST, TDRST, ALL-H to GND	-0.3 to 6.0	V
VGH, RE to GND	-0.3 to 39.0	V
DSCH, CLK1~6, ODD, BRST, VST, VGH to VGL	-0.3 to 54.0	V
VGL, EVEN to GND	-15.0 to +0.3	V
Power Dissipation, PD @ $T_A=70^{\circ}\text{C}$ ⁽¹⁾	2 (Max.)	W
Package Thermal Resistance (θ_{JA})	40 (Max.)	$^{\circ}\text{C}/\text{W}$
Operating ambient temperature range ⁽²⁾	-25 to +85	$^{\circ}\text{C}$
Operating Junction temperature range ⁽²⁾	-25 to +125	$^{\circ}\text{C}$
Ambient Storage Temperature	-65 to +150	$^{\circ}\text{C}$
ESD HBM Rating	2	kV
ESD MM Rating	200	V
ESD CDM Rating	700	V

Note :

- 1) Highly depends on the PCB heat dissipation. Tester with the Thermal Characteristics the condition below $T_A=70^{\circ}\text{C}$
- 2) Measured in still air-free convection condition(conforms to EIA/JESD51-2) on high effective thermal conductivity JESD51-7 test board.

Electrical Characteristics

$V_{IN}=3.3V$, $V_{GH} = 20V$, $V_{GL} = -8.5V$: $T_A=-25^{\circ}C$ to $+85^{\circ}C$, Typical values are at $T_A=25^{\circ}C$ (unless otherwise noted.)

Symbol	Parameter	Test Conditions	Min.	Typ.	Max.	Unit
General Section						
V_{IN}	Input Voltage Range		2.2	3.3	5.0	V
I_Q	Quiescent Current	LS Input =GND, No Load		0.01	1	mA
I_{GH}	VGH Supply Current	LS Input =GND, No Load		1	2	mA
I_{GL}	VGL Supply Current	LS Input =GND, No Load		0.3	0.5	mA
$V_{IN_UVLO_H}$	V_{IN} UVLO Rising Threshold			2.0		V
T_{LIMIT}	Thermal Shutdown ^(Note1)			150		$^{\circ}C$
T_{HYST}	Thermal Shutdown Hysteresis ^(Note1)			30		$^{\circ}C$
Level Shifter						
V_{GH}	V_{GH} Input Voltage Range	$V_{IN}=3.3V$	5	20	37.5	V
V_{GL}	V_{GL} Input Voltage Range	$V_{IN}=3.3V$	-15	-8.5	-5	V
$V_{GH}-V_{GL}$	V_{GH} to V_{GL} Voltage Range ^(Note1)	$V_{IN}=3.3V$	10		53	V
V_{OH}	Output High Voltage	$I_H=-10mA$	$V_{GH}-1$			V
V_{OL}	Output Low Voltage	$I_H=+10mA$			$V_{GL}+1$	V
$V_{GH_UVLO_H}$	V_{GH} UVLO Rising Threshold			4		V
$V_{GH_UVLO_L}$	V_{GH} UVLO Falling Threshold			3		V
t_{PH}	Propagation Rising Delay	$C_{LOAD}=100pF$, 50% to 50%		100	200	ns
t_{PL}	Propagation Falling Delay	$C_{LOAD}=100pF$, 50% to 50%		150	300	ns
t_R	Rising time	$C_{LOAD}=100pF$, 10% to 90%		10	70	ns
t_F	Falling time	$C_{LOAD}=100pF$, 90% to 10%		15	70	ns
t_{in_min}	Minimum On time ^(Note1)		100			ns
f_{MAX}	Maximum Operating Frequency ^(Note1)	$C_{LOAD}=100pF$			200	kHz
R_{RE}	RE Resistance ^(Note1)			300		Ω
ROH	CLK1~6 Output Impedance	$I_{OH}=-10mA$		12		Ω
ROL	CLK1~6 Output Impedance	$I_{OH}=+10mA$		7		Ω
ROH	ODD, DSCH, VGH, BRST Output Impedance	$I_{OH}=-10mA$		35		Ω
ROL	ODD, DSCH, VGH, BRST Output Impedance	$I_{OH}=+10mA$		16		Ω
Discharging						
V_{DIS}	Enable Start ^(Note1)	ALL-H Falling		1.8		V
$V_{ALL_H_IH}$	ALL_H High Level Input Voltage		1.4			V
$V_{ALL_H_IL}$	ALL_H Low Level Input Voltage				0.6	V
Logic Input (GST, ONCLK, OFFCLK, TDRST)						
V_{IH}	High Level Input Voltage		1.4			V
V_{IL}	Low Level Input Voltage				0.6	V
I_{IL}	Input Leakage Current	ON_CLK=OFF_CLK=0V	-1		1	μA

Note1) Guaranteed by design, characterization and correlation with process controls, Not fully tested in production

Level shifters

The MSI6000 has the 11-channel high voltage level shifter. It is designed to shift the level of a logic signal to VGH or VGL. VGH is positive supplies with voltage range for +5V to +37.5V. and VGL is the negative supply with voltage range for -15V to -5V.

Figure 2 contains a simplified block diagram of one channel with gate voltage shaping.

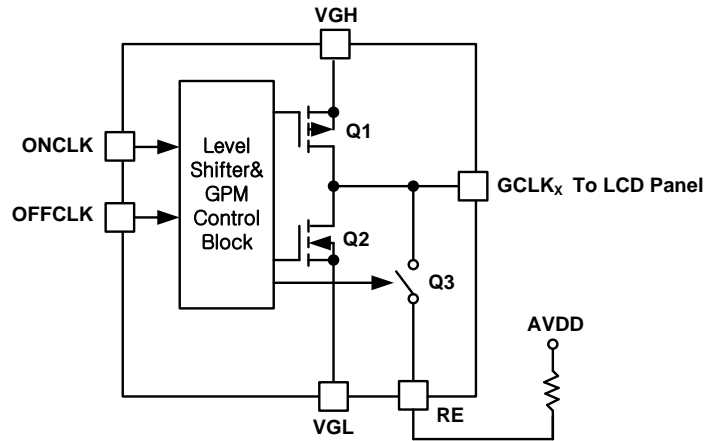

Figure 2) Level shifter Channel with Gate Voltage Shaping

On the rising edge of ONCLK, Q1 turns on, Q2 turns off and Q3 is turned on during a certain time which is set by the RE resistor. So GCLK1 is charged by AVDD voltage through the RE resistor. After that, Q3 is turned off and Q1 is turned on and GCLK1 voltage goes up to VGH. On the rising edge of OFFCLK, Q1 turns off, Q3 is turned on, and GCLK1 voltage slices through Q3 and the RE resistor is connected to RE pin. On the falling edge of OFFCLK, Q2 is turned on and Q3 is turned off, and GCLK1 voltage is driven to VGL.

This sequence is shown in the below figure.

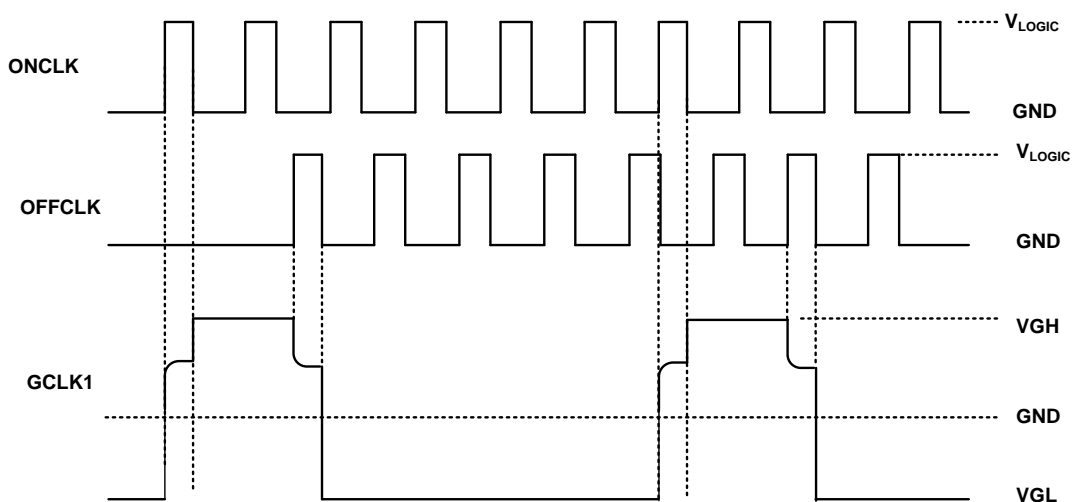

Figure 3) Gate Voltage Shaping Timing Diagram

Power Sequence

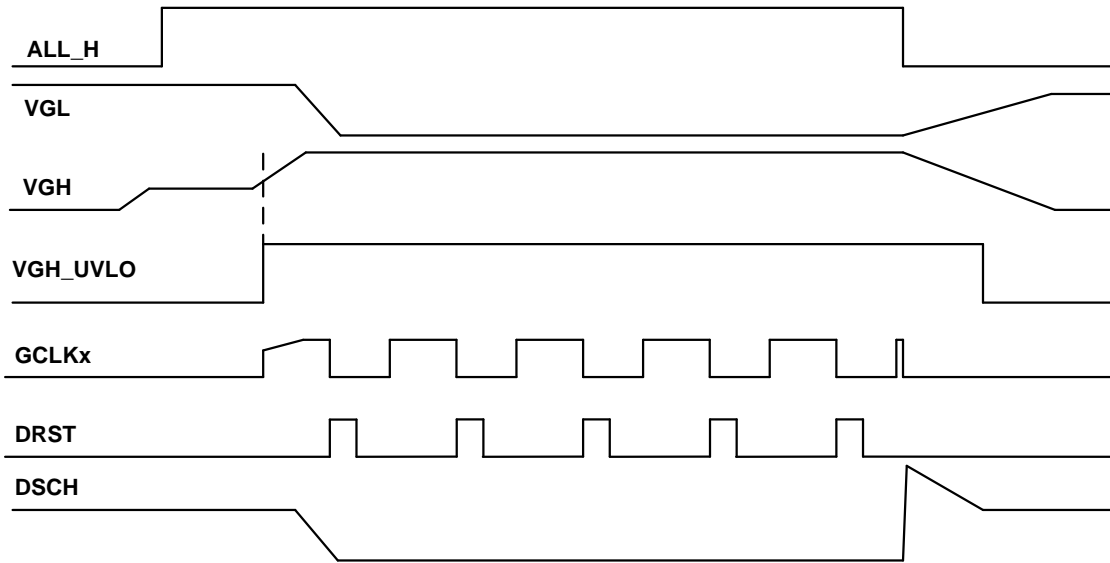

Figure 4) Power Sequence

Level shifter Input / Output Waveform

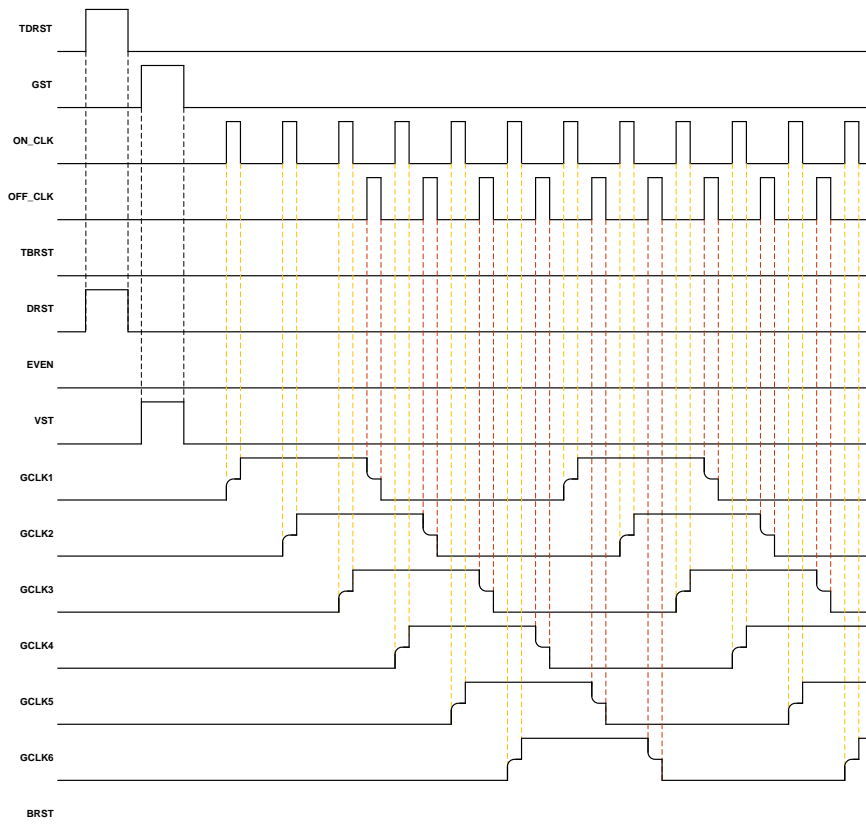

Figure 5) Timing Diagram, Start of Frame

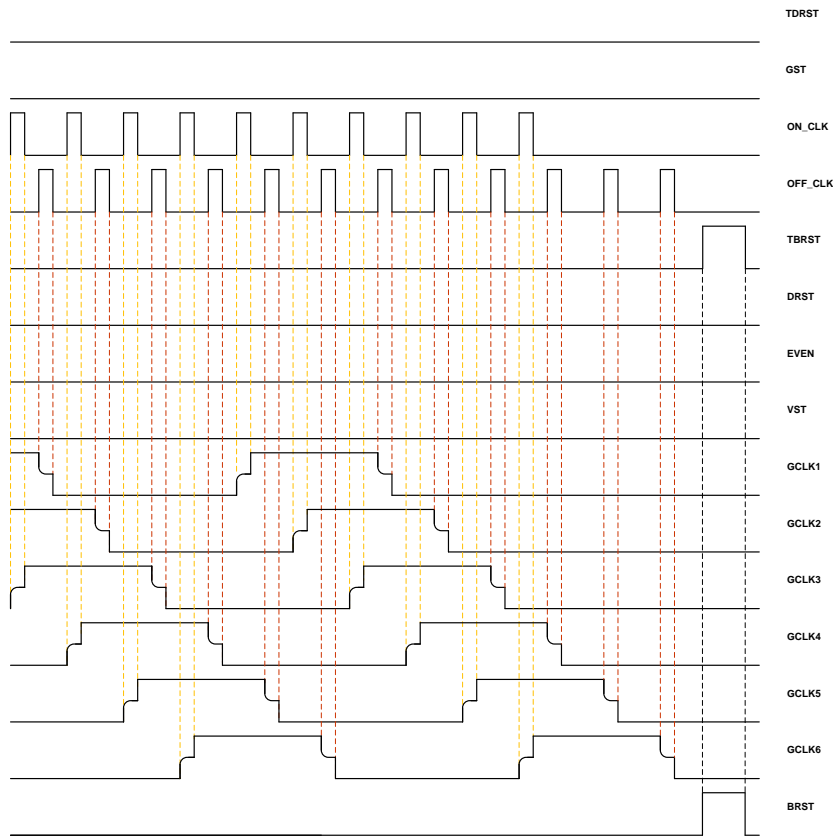
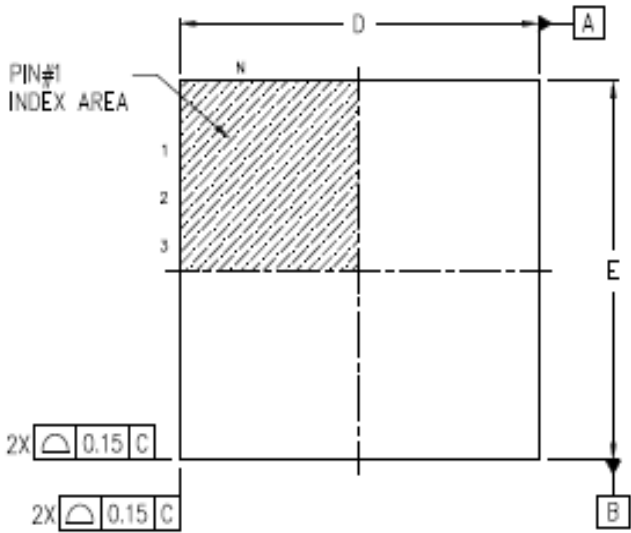
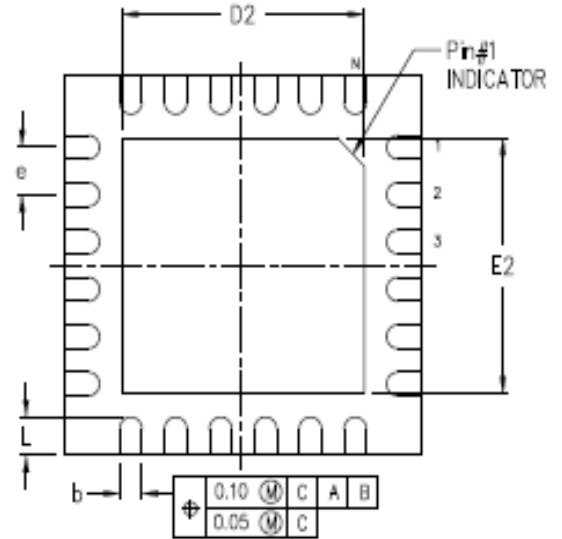

Figure 6) Timing Diagram, End of Frame

Package Dimensions



TOP VIEW



BOTTOM VIEW

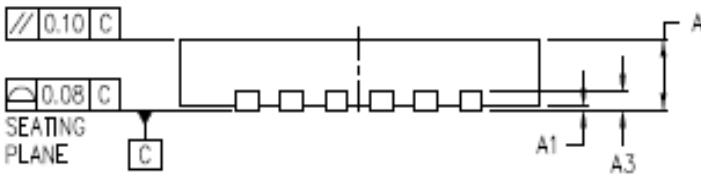

SIDE VIEW

Symbol	Dimension (mm)		
	Min	Nom	Max
A	0.70	0.75	0.80
A1	0.00	0.02	0.05
A3	0.20 REF		
D	3.85	4.00	4.15
E	3.85	4.00	4.15
D2	2.60	2.70	2.80
E2	2.60	2.70	2.80
b	0.18	0.25	0.30
e	0.50 BSC		
L	0.30	0.40	0.50

REVISION HISTORY

Date	Version	Changes
2014-12-05	Version 0.0	Initial Version
2015-02-12	Version 0.1	Update the description
2015-09-01	Version 0.2	Mode 2 Option Cancel Package POD update VIH Threshold voltage level change
2015-11-04	Version 0.3	Update Absolute Maximum Rate
2016-01-19	Version 0.4	Update Pin Description (Option → NC)
2016-05-27	Version 1.0	Update Final Datasheet
2016-06-10	Version 1.1	Update Power Sequence Update Package Dimension Format Update BOM File