

▲ CIRCUIT: SPST

NOTES

1. ALL DIMENSIONS IN MM [INCH]
2. GENERAL TOLERANCE: X.X=± 0.4
X.XX=± 0.25
3. TERMINAL NUMBERS FOR REF. ONLY.
- ▲ 4. OPERATING FORCE: 160 ± 50gf
5. OPERATING LIFE: 1,000,000 CYCLES
6. TRAVEL: 0.5 ± 0.15mm
7. CONTACT RATING: 12VDC @ 50mA
8. CONTACT RESISTANCE: 100mΩ MAX
9. INSULATION RESISTANCE: 100MΩ MIN @ 100VDC.
- ▲ 10. CONTACT MATERIAL: SILVER
11. OPERATING TEMPERATURE: -40°C TO 85°C
12. PACKAGING: TAPE & REEL, 700 PCS. PER REEL
13. ▲DENOTES CRITICAL PARAMETER
14. 2002/95/EC (ROHS) COMPLIANT

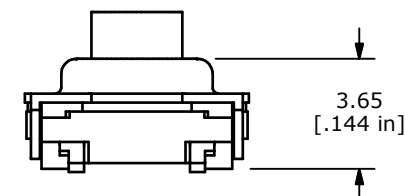
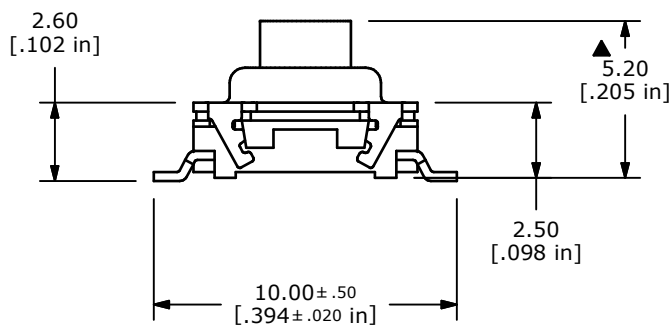

TITLE TL6120BF160QG				
SCALE	DATE 11/7/2013	DR EBP	DWG T351507	REV A

THE INFORMATION CONTAINED IN THIS DOCUMENT IS PROPRIETARY TO E-SWITCH AND IS NOT TO BE COPIED OR TRANSFERRED