



MAX9517/MAX9524 Evaluation Kits

General Description

The MAX9517/MAX9524 evaluation kits (EV kits) are fully assembled and tested surface-mount PCBs that evaluate the MAX9517 and the MAX9524 ICs. Both ICs filter, amplify, and set the sync-tip level for standard-definition video signals.

The ICs feature an internal reconstruction filter that has 40dB attenuation at 27MHz, and ± 1 dB passband flatness at 7MHz. The MAX9517 and MAX9524 have a 2V/V gain and are capable of driving 75 Ω to ground. The ICs feature two analog switches that are used to route audio, video, or digital signals.

Video signals are DC-coupled to the input of the MAX9517 and AC-coupled to the input of the MAX9524. The MAX9524 features an input sync-tip clamp to set the DC level for the video signal. The EV kits' input terminal has 75 Ω termination to ground. The EV kits' output has a 75 Ω back-termination resistor. The EV kits operate from a single 2.7V to 3.6V power supply.

Part Selection Table

PART	INPUT COUPLING	OUTPUT COUPLING
MAX9517ATC+	DC	DC
MAX9524ATC+	AC with sync-tip clamp	DC

DESIGNATION	QTY	DESCRIPTION
C1	1	10 μ F $\pm 20\%$, 6.3V X5R ceramic capacitor (0603) Murata GRM188R60J106M
C2	1	0.1 μ F $\pm 10\%$, 25V X7R ceramic capacitor (0603) TDK C1608X7R1E104K
C3	1	See the <i>EV Kit-Specific Component List</i>
COM1, COM2, IN, NO1, NO2, OUT	6	75 Ω BNC PCB mount connectors
JU1, JU2, JU3	3	3-pin headers
R1, R2	2	75 Ω $\pm 1\%$ resistors (0603)
R3	1	See the <i>EV Kit-Specific Component List</i>
R4-R7	0	Not installed, resistors (0603)
U1	1	See the <i>EV Kit-Specific Component List</i>
—	3	Shunts
—	1	PCB: MAX9517/MAX9524 Evaluation Kits+

Features

- ◆ Single 2.7V to 3.6V Supply Operation
- ◆ DC-Coupled Input (MAX9517)
- ◆ AC-Coupled Input with Sync-Tip Clamp (MAX9524)
- ◆ ± 1 dB Passband at 7MHz Reconstruction Filter with 40dB Attenuation at 27MHz
- ◆ Preset Gain of 2V/V
- ◆ Drives 75 Ω to Ground
- ◆ Small 12-Pin Thin QFN Package
- ◆ Fully Assembled and Tested

Ordering Information

PART	TEMP RANGE	IC PACKAGE
MAX9517EVKIT+	0°C to +70°C*	12 Thin QFN-EP** (3mm x 3mm)
MAX9524EVKIT+	0°C to +70°C*	12 Thin QFN-EP** (3mm x 3mm)

+Denotes a lead-free and RoHS-compliant EV kit.

*This limited temperature range is for the EV kit PCB only. The MAX9517 and MAX9524 IC temperature range is -40°C to +125°C.

**EP = Exposed paddle.

Component List

EV Kit-Specific Component List

EV KIT	REFERENCE DESIGNATOR	DESCRIPTION
MAX9517EVKIT+	C3	Not installed, capacitor (0603)
	R3	0 Ω $\pm 5\%$ resistor (0603)
	U1	MAX9517ATC+ (12-pin, 3mm x 3mm Thin QFN with EP)
MAX9524EVKIT+	C3	0.1 μ F $\pm 10\%$, 25V X7R, ceramic capacitor (0603) TDK C1608X7R1E104K
	R3	Not installed, resistor (0603)
	U1	MAX9524ATC+ (12-pin, 3mm x 3mm Thin QFN with EP)

MAX9517/MAX9524 Evaluation Kits

Component Suppliers

SUPPLIER	PHONE	WEBSITE
Murata Mfg. Co., Ltd.	770-436-1300	www.murata.com
TDK Corp.	847-803-6100	www.component.tdk.com

Note: Indicate that you are using the MAX9517 or MAX9524 when contacting these component suppliers.

Quick Start

Recommended Equipment

- 2.7V to 3.6V, 500mA DC power supply (VDD)
- Video signal generator
- Video measurement equipment (e.g., Tektronix VM-700T)

Procedure

Each EV kit is a fully assembled and tested surface-mount PCB. Follow the steps below to verify board operation. **Caution: Do not turn on the power supply until all connections are completed.**

- 1) Verify that a shunt is installed across pins 1-2 of jumper JU1 (EV Kit ON).
- 2) Connect the power-supply ground to the GND pad on the EV kit.
- 3) Connect the 2.7V to 3.6V power supply to the VDD pad on the EV kit.
- 4) Connect the output of the video signal generator to the IN BNC connector on the EV kit. **Note:** For the MAX9517, the video signal must be biased such that the sync tip is at ground.
- 5) Connect the OUT BNC connector on the EV kit to the input of the video measurement equipment.
- 6) Set the video signal generator for the desired video input signal, such as multiburst sweep. This signal must contain sync information.
- 7) Turn on the power supply and enable the video signal generator.
- 8) Analyze the video output signal with the VM-700T video measurement equipment.

Detailed Description

Each EV kit is a fully assembled and tested PCB that contains all the components necessary to evaluate the performance of the MAX9517 or the MAX9524. Both ICs filter and amplify standard-definition video signals.

The MAX9517/MAX9524 ICs feature an internal reconstruction filter that has 40dB attenuation at 27MHz and ± 1 dB passband flatness at 7MHz. The MAX9517 and MAX9524 have 2V/V gain and are capable of driving a 75 Ω load to ground. Both ICs include two analog switches that can be used to route audio, video, or digital signals.

The MAX9517 EV kit can be modified to evaluate the MAX9524 by installing capacitor C3, removing resistor R3, and replacing U1. See the *EV-Kit Specific Component List* for component values.

Similarly, the MAX9524 EV kit can be modified to evaluate the MAX9517 by removing capacitor C3, installing resistor R3, and replacing U1. See the *EV-Kit Specific Component List* for component values.

Jumper Selection

Shutdown Mode ($\overline{\text{SHDN}}$)

Jumper JU1 controls the shutdown mode ($\overline{\text{SHDN}}$) of the MAX9517 or MAX9524 ICs. The shutdown mode reduces the IC's quiescent current. See Table 1 for shunt positions.

Table 1. JU1 Jumper Selection ($\overline{\text{SHDN}}$)

SHUNT POSITION	$\overline{\text{SHDN}}$ PIN	EV KIT FUNCTION
1-2*	High	Enabled
2-3	Low	Disabled

*Default position.

MAX9517/MAX9524 Evaluation Kits

Analog Switch Control (IN1)

The ICs feature a logic input, IN1, to control analog switch 1. Jumper JU2 on the EV kit controls analog switch 1. Table 2 lists the selectable jumper options.

Analog Switch Control (IN2)

The ICs feature a logic input, IN2, to control analog switch 2. Jumper JU3 on the EV kit controls analog switch 2. Table 3 lists the selectable jumper options.

Table 2. JU2 Jumper Selection (IN1)

SHUNT POSITION	IN1 CONNECTED TO	ANALOG SWITCH 1	EV KIT FUNCTION
1-2	VDD	On	NO1 connected to COM1
2-3	GND	Off	NO1 not connected to COM1
None	External logic control source	Controlled by an external logic control source	Logic-high: NO1 connected to COM1 Logic-low: NO1 not connected to COM1

Table 3. JU3 Jumper Selection (IN2)

SHUNT POSITION	IN2 CONNECTED TO	ANALOG SWITCH 2	EV KIT FUNCTION
1-2	VDD	On	NO2 connected to COM2
2-3	GND	Off	NO2 not connected to COM2
None	External logic control source	Controlled by an external logic control source	Logic-high: NO2 connected to COM2 Logic-low: NO2 not connected to COM2

Evaluate: MAX9517/MAX9524

MAX9517/MAX9524 Evaluation Kits

Evaluate: MAX9517/MAX9524

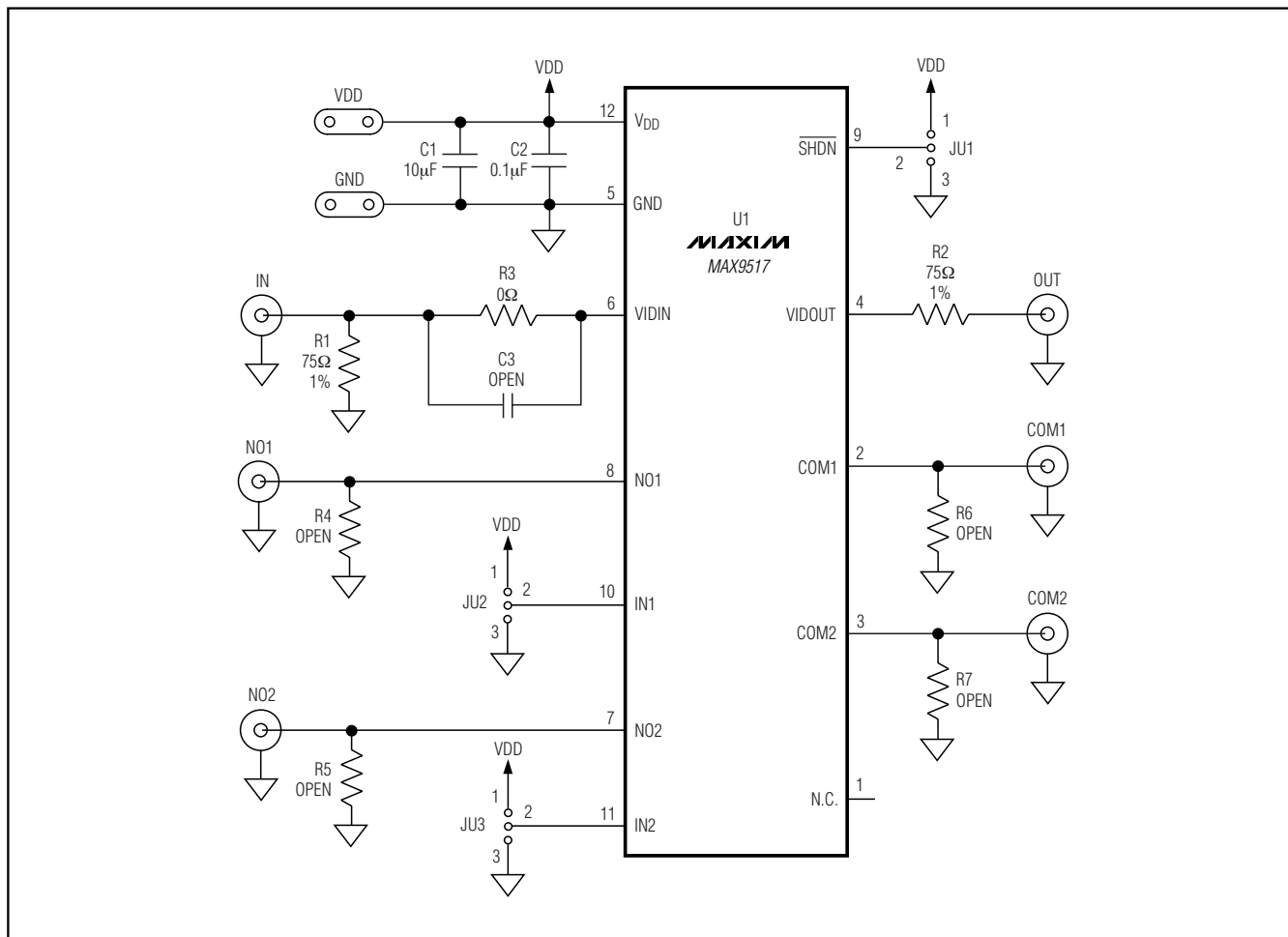

Figure 1. MAX9517 EV Kit Schematic

MAX9517/MAX9524 Evaluation Kits

Evaluate: MAX9517/MAX9524

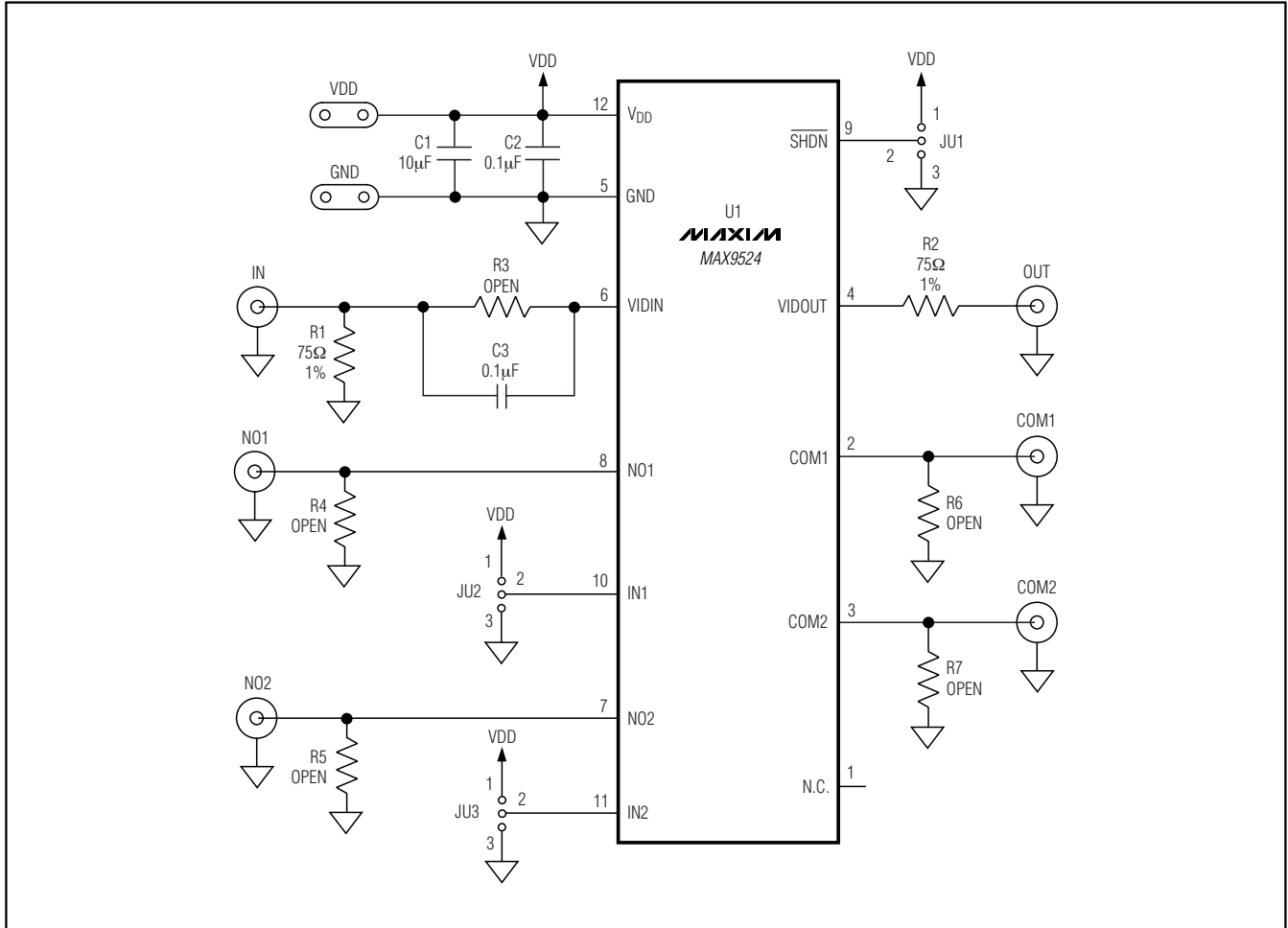

Figure 2. MAX9524 EV Kit Schematic

MAX9517/MAX9524 Evaluation Kits

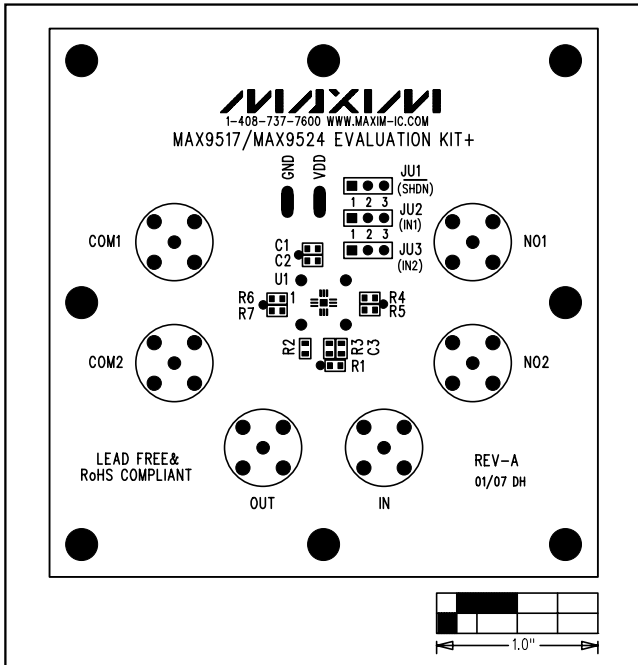

Figure 3. MAX9517/MAX9524 EV Kit Component Placement Guide—Component Side

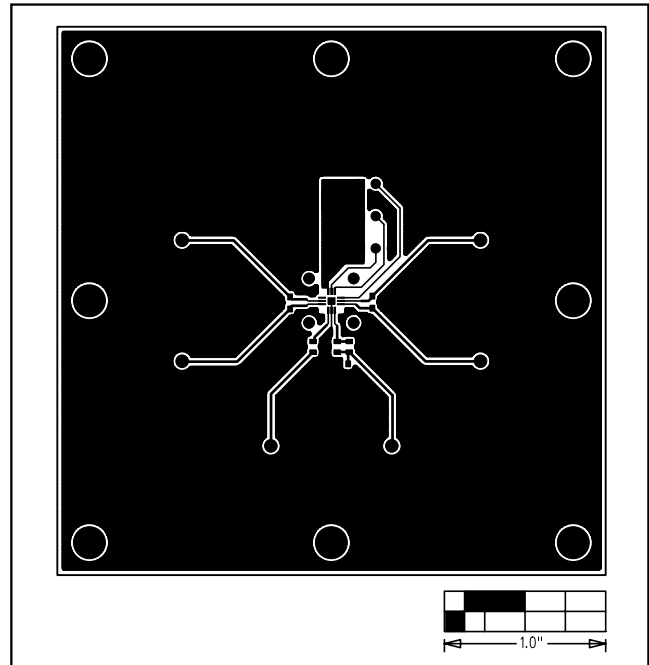

Figure 4. MAX9517/MAX9524 EV Kit PCB Layout—Component Side

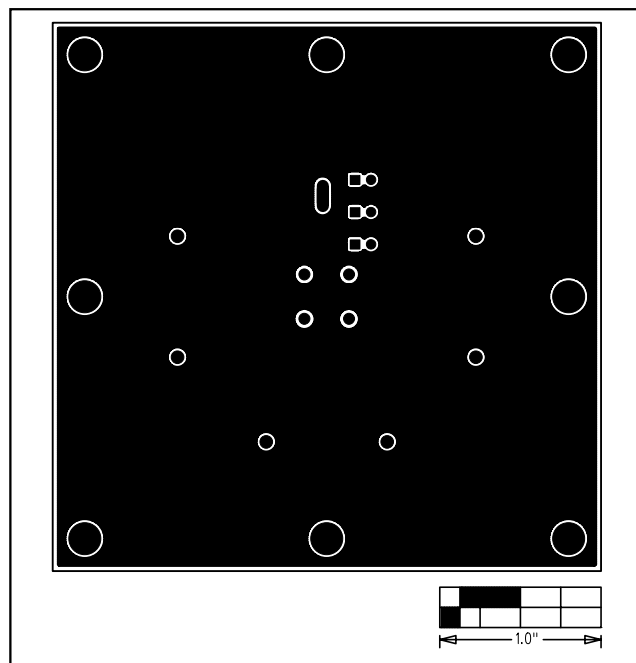

Figure 5. MAX9517/MAX9524 EV Kit PCB Layout—Solder Side

Maxim cannot assume responsibility for use of any circuitry other than circuitry entirely embodied in a Maxim product. No circuit patent licenses are implied. Maxim reserves the right to change the circuitry and specifications without notice at any time.

6 **Maxim Integrated Products, 120 San Gabriel Drive, Sunnyvale, CA 94086 408-737-7600**

© 2007 Maxim Integrated Products

MAXIM is a registered trademark of Maxim Integrated Products, Inc.