



P4SMAFJ8.5A THRU P4SMAFJ170A

SURFACE MOUNT TRANSIENT VOLTAGE SUPPRESSOR

Stand-off Voltage: 8.5-170 Volts Peak pulse power: 400 Watts

SMAF

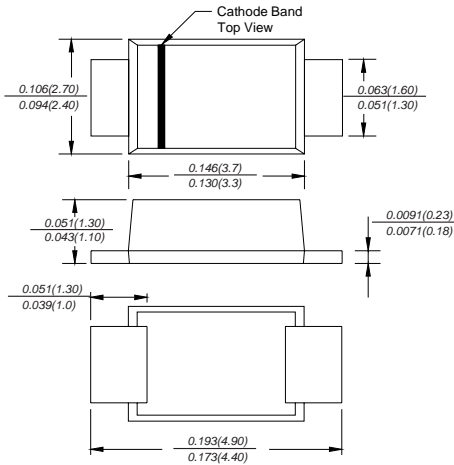

FEATURE

- ◆ For surface mounted applications in order to optimize board space
- ◆ Low profile package
- ◆ Glass passivated junction
- ◆ Low inductance
- ◆ Plastic package has underwriters laboratory flammability 94V-0

MECHANICAL DATA

Case: SMAF

Terminal: Solder plated, solderable per MIL-STD-750, Method 2026

Weight: 27mg 0.00095oz

MAXIMUM RATINGS AND CHARACTERISTICS

Ratings at 25°C ambient temperature unless otherwise specified.

Parameter	Symbol	Value	Unit
Peak Pulse Power Dissipation on TA=25°C (Note 1,2,4, Fig1)	P _{PPM}	400	W
Peak Forward Surge Current (Note 3, Fig 5)	I _{FSM}	40	A
Peak Pulse Current on 10/1000 us waveform (Note 1, Fig 2)	I _{PPM}	see Table 1	A
Typical Junction capacitance at VR=4V, f=1MHz	C _J	390	pF
ESD Voltage per IEC6100-4-2	Contact	V _{ESD1}	± 8
	Air	V _{ESD2}	±15
Typical Thermal Resistance Junction to Ambient(Note 2)	R _{θJA}	150	°C/W
Operating Junction Temperature and Storage Temperature Range	T _j , T _{stg}	-55 ~ +150	°C

NOTES:

1. Non-repetitive current pulse, per Fig.3 and derated above TA = 25°C per Fig. 2.
2. Mounted on FR-4 PCB single-sided copper, mini pad.
3. Peak Forward Surge Current : 8.3ms single half sine-wave Superimposed on rated load (JEDEC method).
4. Peak pulse power waveform is 10/1000µS.



Electrical Characteristics (TA=25°C)

Type	Marking	Reverse Stand-off Voltage	Breakdown Voltage		Test Current	Reverse Leakage	Max. Clamp Voltage	Peak Pulse Current
		V _{RWM}	V _{BR} @ I _T		I _T	I _R @ V _{RWM}	V _C @ I _{PP}	I _{PP}
			Min	Max				
		V	V	V	mA	µA	V	A
P4SMAFJ8.5A	HT	8.5	9.44	10.82	1	10	14.4	27.7
P4SMAFJ9.0A	HV	9.0	10	11.5	1	5	15.4	26
P4SMAFJ10A	HX	10	11.1	12.8	1	5	17	23.5
P4SMAFJ11A	HZ	11	12.2	14	1	1	18.2	22
P4SMAFJ12A	IE	12	13.3	15.3	1	1	19.9	20.1
P4SMAFJ13A	IG	13	14.4	16.5	1	1	21.5	18.6
P4SMAFJ14A	IK	14	15.6	17.9	1	1	23.2	17.2
P4SMAFJ15A	IM	15	16.7	19.2	1	1	24.4	16.4
P4SMAFJ16A	IP	16	17.8	20.5	1	1	26	15.3
P4SMAFJ17A	IR	17	18.9	21.7	1	1	27.6	14.5
P4SMAFJ18A	IT	18	20	23.3	1	1	29.2	13.7
P4SMAFJ20A	IV	20	22.2	25.5	1	1	32.4	12.3
P4SMAFJ22A	IX	22	24.4	28	1	1	35.5	11.2
P4SMAFJ24A	IZ	24	26.7	30.7	1	1	38.9	10.3
P4SMAFJ26A	JE	26	28.9	33.2	1	1	42.1	9.5
P4SMAFJ28A	JG	28	31.1	35.8	1	1	45.4	8.8
P4SMAFJ30A	JK	30	33.3	38.3	1	1	48.4	8.3
P4SMAFJ33A	JM	33	36.7	42.2	1	1	53.3	7.5
P4SMAFJ36A	JP	36	40	46	1	1	58.1	6.9
P4SMAFJ40A	JR	40	44.4	51.1	1	1	64.5	6.2
P4SMAFJ43A	JT	43	47.8	54.9	1	1	69.4	5.7
P4SMAFJ45A	JV	45	50	57.5	1	1	72.7	5.5
P4SMAFJ48A	JX	48	53.3	61.3	1	1	77.4	5.2
P4SMAFJ51A	JZ	51	56.7	65.2	1	1	82.4	4.9
P4SMAFJ54A	RE	54	60	69	1	1	87.1	4.6
P4SMAFJ58A	RG	58	64.4	74.1	1	1	93.6	4.3
P4SMAFJ60A	RK	60	66.7	76.7	1	1	96.8	4.1
P4SMAFJ64A	RM	64	71.1	81.8	1	1	103	3.9
P4SMAFJ70A	RP	70	77.8	89.5	1	1	113	3.5
P4SMAFJ75A	RR	75	83.3	95.8	1	1	121	3.3
P4SMAFJ78A	RT	78	86.7	99.7	1	1	126	2.2
P4SMAFJ85A	RV	85	94.4	108	1	1	137	2.9
P4SMAFJ90A	RX	90	100	116	1	1	146	2.7
P4SMAFJ100A	RZ	100	111	128	1	1	162	2.5
P4SMAFJ110A	SE	110	122	141	1	1	177	2.3
P4SMAFJ120A	SG	120	133	153	1	1	193	2
P4SMAFJ130A	SK	130	144	166	1	1	209	1.9
P4SMAFJ150A	SM	150	167	193	1	1	243	1.6
P4SMAFJ160A	SP	160	178	205	1	1	259	1.5
P4SMAFJ170A	SR	170	189	218	1	1	275	1.4

RATINGS AND CHARACTERISTIC CURVES P4SMAFJ8.5A THRU P4SMAFJ170A

Fig.1 Peak Pulse Power Rating Curve

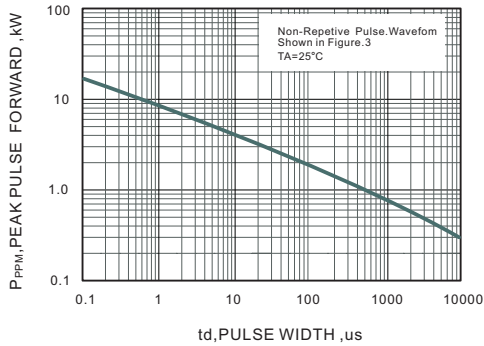

Fig.2 Forward Current Derating Curve

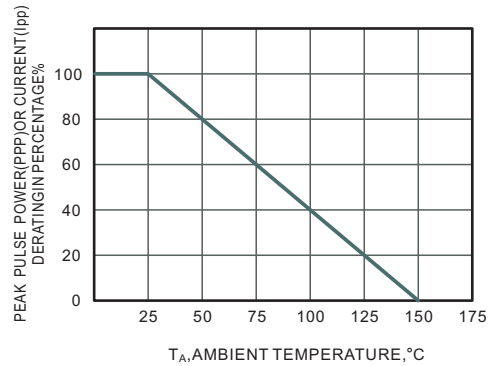

Fig.3 Pulse Waveform

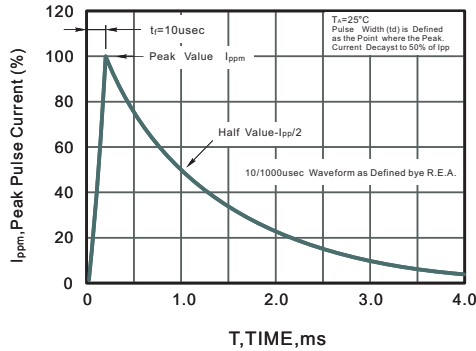

Fig.5 Maximum Non-Repetitive Peak Forward Surge Current

