

## HDMI 2.0, DisplayPort 1.2 Video Switch

### Features

- 4-lane, 1:2 mux/demux that will support RBR, HBR1, or HBR2
- Data rate: 3.4 Gbps to 6.0 Gbps for high data channels
- Supports DDC with HPD channel mux/demux @ HDMI
- Supports 720 Mbps high-speed DP AUX @ DP
- -1.7 dB Insertion Loss for Dx channels @ 3.0 GHz
- -3 dB Bandwidth for Dx channels: 4.8 GHz
- Return loss for Dx channels @ 3.0 GHz: -16 dB
- Low Crosstalk for high speed channels: -25 dB@6.0 Gbps
- Low Off Isolation for high speed channels: -22dB@6.0 Gbps
- Low channel-to-channel skew, 35ps max
- Low Bit-to-Bit Skew, 5ps typ (between '+' and '-' bits)
- V<sub>DD</sub> Operating Range: 3.3V +/-10%
- ESD Tolerance: 2kV HBM
- Packaging (Pb-free & Green): 42 TQFN (ZHE)

### Description

Pericom Semiconductor's PI3WVR12412 is a multi-standard video switch with wide voltage range capability. It supports HDMI 2.0, DisplayPort 1.2, and emerging and proprietary standard.

PI3WVR12412 can pass high-speed signals up to 1.2 V peak-to-peak differential with a common-mode voltage from 0 to 3.4V for TMDS signal.

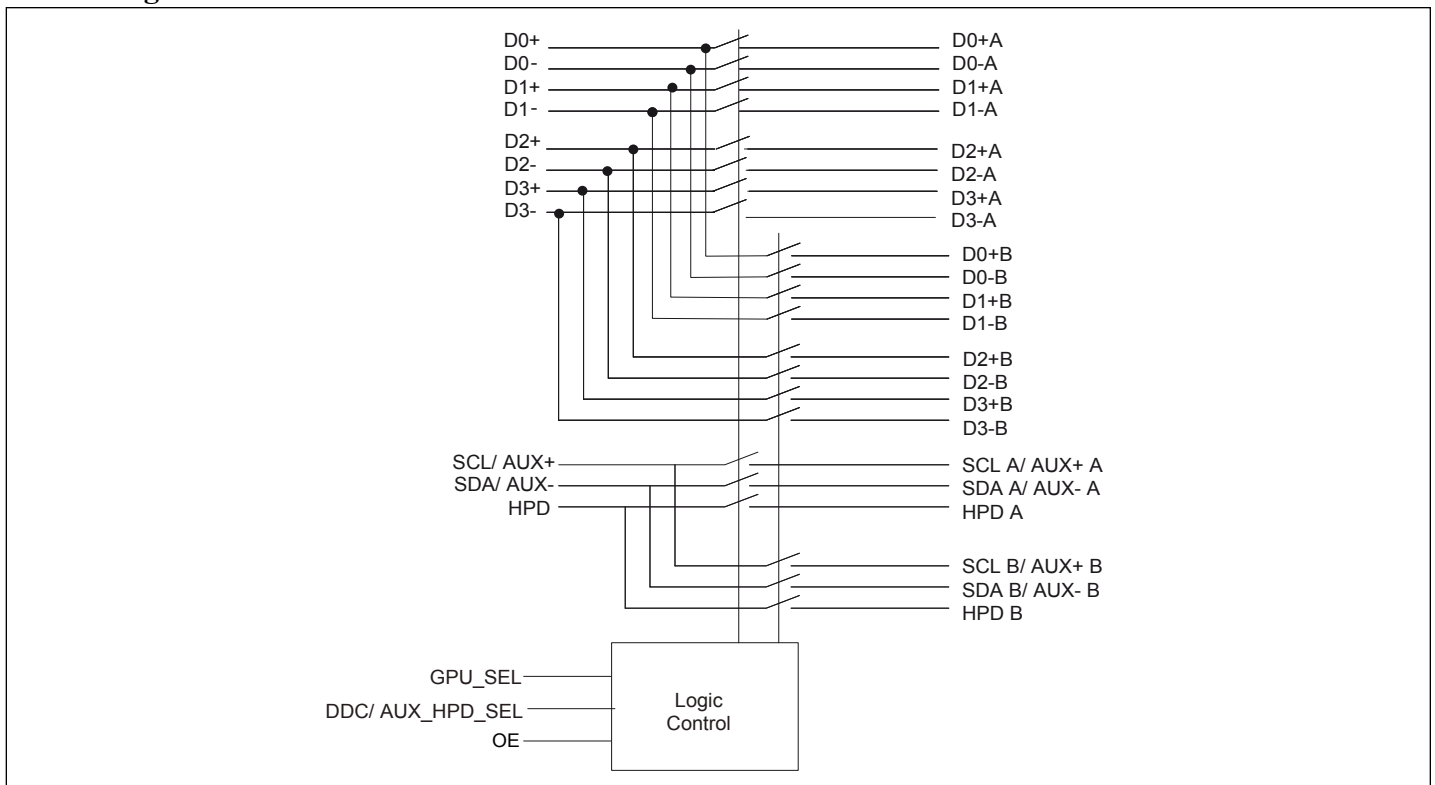
The wide voltage range allow DC-coupled multi-standard operation. Eliminating AC coupling capacitors saves board space and improves signal integrity for dense PCB design. The high speed channels can also pass 0V-3.3V CMOS signals up to 1MHz.

In addition to four high-speed lanes, PI3WVR12412 also switches the DDC and HPD signals or AUX and HPD signals using the DDC/ AUX and HPD channel mux/demux.

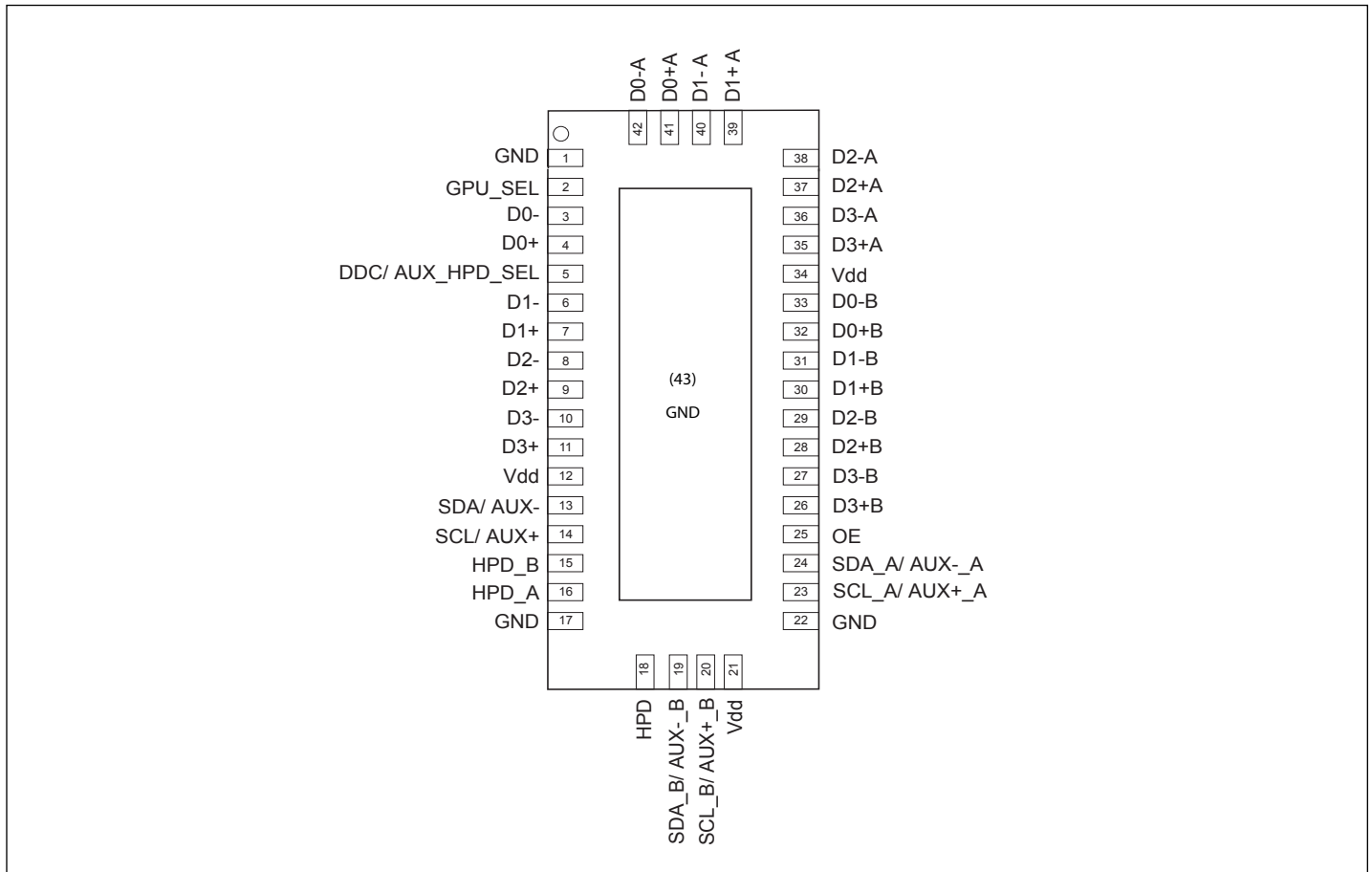
### Application

- Routing of HDMI 2.0 video signals with low signal attenuation between source and sink for 4K2K ultra high definition video display and broadcast video equipment.
- Routing of DisplayPort video signals with low signal attenuation between source and sink for PC and monitor.

### Block Diagram



**Pin Assignment (TQFN-42, ZHE)**



**Truth Table**

Control			Switch Function		
OE	GPU_SEL	DDC/ AUX_HPDA_SEL	D0-D3	DDC/ AUX	HPD
High	Low	Low	A	DDC A/ AUX A	HPD A
High	Low	High	A	DDC B/ AUX B	HPD B
High	High	Low	B	DDC A/AUX A	HPD A
High	High	High	B	DDC B/ AUX B	HPD B
Low	x	x	Hi-Z	Hi-Z	Hi-Z

**Pin Description**

pin#	pin Name	Signal Type	Description
1	GND	Ground	Ground
2	GPU_SEL	I	switch logic control
3	D0-	I/O	negative differential signal 0 for COM port
4	D0+	I/O	positive differential signal 0 for COM port
5	DDC/ AUX_HPDP_SEL	I	Switch logic control for DDC/ AUX and HPD
6	D1-	I/O	negative differential signal 1 for COM port
7	D1+	I/O	positive differential signal 1 for COM port
8	D2-	I/O	negative differential signal 2 for COM port
9	D2+	I/O	positive differential signal 2 for COM port
10	D3-	I/O	negative differential signal 3 for COM port
11	D3+	I/O	positive differential signal 3 for COM port
12	VDD	Power	3.3V +/-10% power supply
13	SDA/ AUX-	I/O	SDA signal for DDC COM port, or negative differential signal for AUX COM port
14	SCL/ AUX+	I/O	SCL signal for DDC COM port, or positive differential signal for AUX COM port
15	HPD_B	I/O	HPD for port B
16	HPD_A	I/O	HPD for port A
17	GND	Ground	Ground
18	HPD	I/O	HPD for COM port
19	SDA_B/ AUX-_B	I/O	SDA signal for DDC, port B, or negative differential signal for AUX COM port
20	SCL_B/ AUX+_B	I/O	SCL signal for DDC, port B, or positive differential signal for AUX COM port
21	VDD	Power	3.3V +/-10% power supply
22	GND	Ground	Ground
23	SCL_A/ AUX+_A	I/O	SCL signal for DDC, port A, or positive differential signal for AUX COM port
24	SDA_A/ AUX-_A	I/O	SDA signal for DDC, port A, or negative differential signal for AUX COM port
25	OE	I	output enable. if OE is high, IC is enabled. if OE is low, IC is power down and all I/Os are Hi-Z
26	D3+B	I/O	positive differential signal 3 for portB
27	D3-B	I/O	negative differential signal 3 for portB
28	D2+B	I/O	positive differential signal 2 for portB
29	D2-B	I/O	negative differential signal 2 for portB
30	D1+B	I/O	positive differential signal 1 for portB
31	D1-B	I/O	negative differential signal 1 for portB

pin#	pin Name	Signal Type	Description
32	D0+B	I/O	positive differential signal 0 for portB
33	D0-B	I/O	negative differential signal 0 for portB
34	VDD	Power	3.3V +/-10% power supply
35	D3+A	I/O	positive differential signal 3 for port A
36	D3-A	I/O	negative differential signal 3 for port A
37	D2+A	I/O	positive differential signal 2 for port A
38	D2-A	I/O	negative differential signal 2 for port A
39	D1+A	I/O	positive differential signal 1 for port A
40	D1-A	I/O	negative differential signal 1 for port A
41	D0+A	I/O	positive differential signal 0 for port A
42	D0-A	I/O	negative differential signal 0 for port A
43	Center pad	Ground	Ground

## Maximum Ratings

(Above which useful life may be impaired. For user guidelines, not tested.)

Storage Temperature ..... -65°C to +150°C	<b>Note:</b> Stresses greater than those listed under MAXIMUM RATINGS may cause permanent damage to the device. This is a stress rating only and functional operation of the device at these or any other conditions above those indicated in the operational sections of this specification is not implied. Exposure to absolute maximum rating conditions for extended periods may affect reliability.
Supply Voltage to Ground Potential ..... -0.5V to +4.2V	
DC Input Voltage ..... -0.5V to $V_{DD}$	
DC Output Current ..... 120mA	
Power Dissipation ..... 0.5W	

## DC Electrical Characteristics for Switching over Operating Range

( $T_A = -40^\circ\text{C}$  to  $+105^\circ\text{C}$ ,  $V_{DD} = 3.3\text{V} \pm 10\%$ )

Parameter	Description	Test Conditions <sup>(1)</sup>	Min	Typ <sup>(2)</sup>	Max	Units
$V_{IH}$	Input HIGH Voltage (SEL & OE)	Guaranteed HIGH level	1.5			V
$V_{IL}$	Input LOW Voltage (SEL & OE)	Guaranteed LOW level			0.75	
$V_{IK}$	Clamp Diode Voltage (HS Channel)	$V_{DD} = \text{Max.}, I_{IN} = -18\text{mA}$		-1.6V	-1.8	
$V_{IK}$	Clamp Diode Voltage (DDC/ AUX, Cntrl )	$V_{DD} = \text{Max.}, I_{IN} = -18\text{mA}$		-0.7	-1.5	
$I_{IH}$	Input HIGH Current	$V_{DD} = \text{Max.}, V_{IN} = V_{DD}$			$\pm 5$	$\mu\text{A}$
$I_{IL}$	Input LOW Current	$V_{DD} = \text{Max.}, V_{IN} = \text{GND}$			$\pm 5$	
$I_{\text{OFF\_SB}}$	I/O leakage when part is off for side-band signals only (DDC/ AUX, HPD)	$V_{DD} = 0\text{V}, V_{\text{INPUT}} = 0\text{V}$ to 3.6V			20	
$R_{\text{ON\_HS}}$	On resistance between input to output for high speed signals	$V_{\text{INPUT,cm}} = 0\text{V}$ to 3.4V, $V_{\text{INPUT,diff}} < 1.2V_{\text{p-p,diff}}$ $V_{DD} = 3.0\text{V}, I_{\text{INPUT}} = 20\text{mA}$		11		Ohm
$R_{\text{ON\_DDC/ AUX}}$	On resistance between input to output for side-band signals (DDC/ AUX)	$V_{DD} = 3.0\text{V}, V_{\text{input}} = 0$ to 3.3V, $I_{\text{INPUT}} = 20\text{mA}$		7		Ohm
$R_{\text{ON\_HPD}}$	On resistance between input to output for HPD channel	$V_{DD} = 3.0\text{V}, V_{\text{input}} = 0$ to 3.0V, $I_{\text{INPUT}} = 20\text{mA}$		7		Ohm
$V_{\text{DDC/ AUX\_SS}}$	Signal Swing Tolerance in DDC/ AUX path	$V_{DD} = 3.0\text{V}$	-0.5		3.6	V
$V_{\text{HPD\_I}}$	Input voltage on HPD path				5.5	V
$V_{\text{HPD\_O}}$	Output voltage tolerance on HPD path	HPD input from 3.3V to 5.25V		3.3	3.6	V

## Power Supply Characteristics

 $(T_A = -40^{\circ}\text{C to } +105^{\circ}\text{C})$ 

Parameter	Description	Test Conditions <sup>(1)</sup>	Min	Typ <sup>(2)</sup>	Max	Units
$I_{DD}$	Power Supply Current	$V_{DD} = 3.3\text{V}, V_{IN} = \text{GND or } V_{DD}$		1	3	mA
$I_{DD,Off}$	Power Supply Current, Disabled	$V_{DD} = 3.3\text{V}, V_{IN} = \text{GND or } V_{DD}, V_{OE} < V_{IL}$		1	50	$\mu\text{A}$

**Note:**

- For Max. or Min. conditions, use appropriate value specified under Electrical Characteristics for the applicable device type.
- Typical values are at  $V_{DD} = 3.3\text{V}, T_A = 25^{\circ}\text{C}$  ambient and maximum loading.

## Dynamic Electrical Characteristics over Operating Range

 $(T_A = -40^{\circ}\text{ to } +105^{\circ}\text{C}, V_{DD} = 3.3\text{V} \pm 10\%)$ 

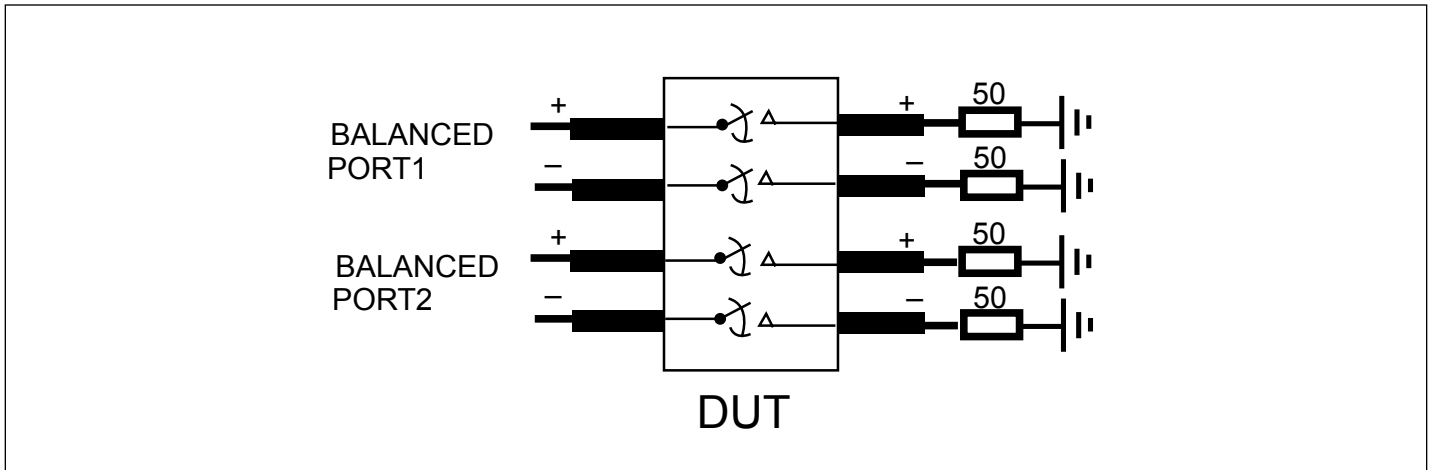
Parameter	Description	Test Conditions <sup>1</sup>	Min	Typ <sup>2</sup>	MAX	Units
$X_{TALK}$	Crosstalk on High Speed Channels	See Fig. 1 for Measurement Setup	$f = 3.0\text{ GHz}$	-25	-22	dB
			$f = 2.7\text{ GHz}$	-28	-25	
			$f = 1.7\text{ GHz}$	-31	-28	
			$f = 1.35\text{ GHz}$	-32	-28	
$O_{IRR}$	OFF Isolation on High Speed Channels	See Fig. 2 for Measurement Setup	$f = 3.0\text{ GHz}$	-22	-20	dB
			$f = 2.7\text{ GHz}$	-22	-20	
			$f = 1.7\text{ GHz}$	-29	-26	
			$f = 1.35\text{ GHz}$	-30	-27	
$I_{LOSS}$	Differential Insertion Loss on High Speed Channels	@3.0 GHz (see figure 3)	-2.0	-1.7	dB	
		@5.4 Gbps (see figure 3)	-2.0	-1.7		
$R_{loss}$	Differential Return Loss on high speed channels	@ 3.0 GHz (6.0Gbps)		-16.0	-14	dB
		@ 2.7 GHz (5.4Gbps)		-14.0	-12.5	
$BW_{Dx\pm}$	Bandwidth -3dB for Main high speed path ( $Dx\pm$ )	See figure 3	3.7	4.8		GHz
$BW_{DDC/AUX/HPD}$	-3dB BW for DDC/ AUX and HPD signals	See figure 3	1.35	1.5		GHz

**Note:**

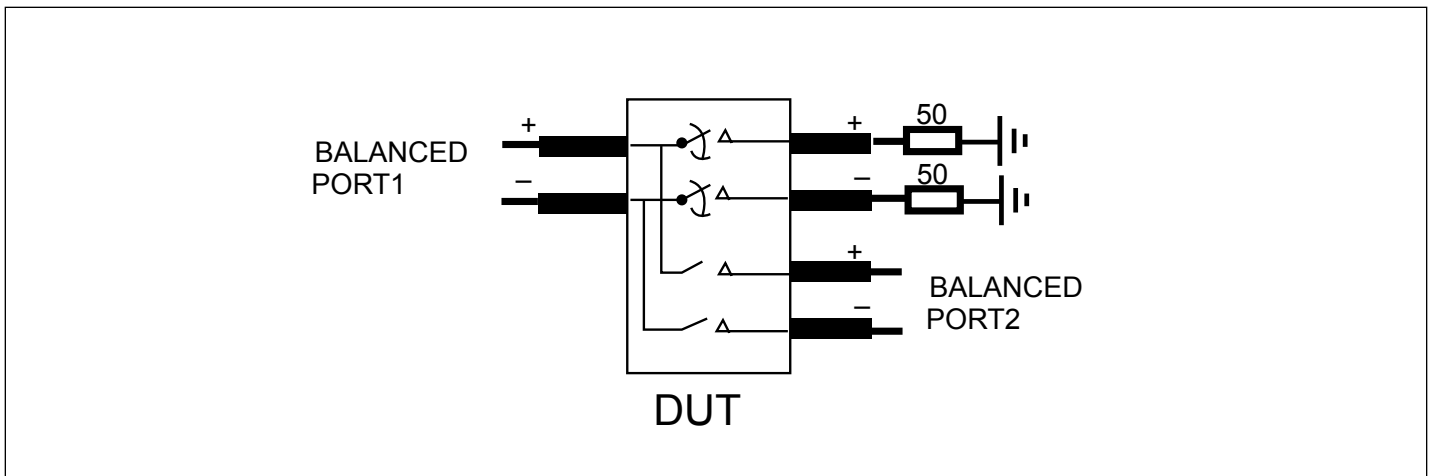
- For Max. or Min. conditions, use appropriate value specified under Electrical Characteristics for the applicable device type.
- Typical values are at  $V_{DD} = 3.3\text{V}, T_A = 25^{\circ}\text{C}$  ambient and maximum loading.

**Switching Characteristics**(T<sub>A</sub> = -40° to +105°C, V<sub>DD</sub> = 3.3V±10%)

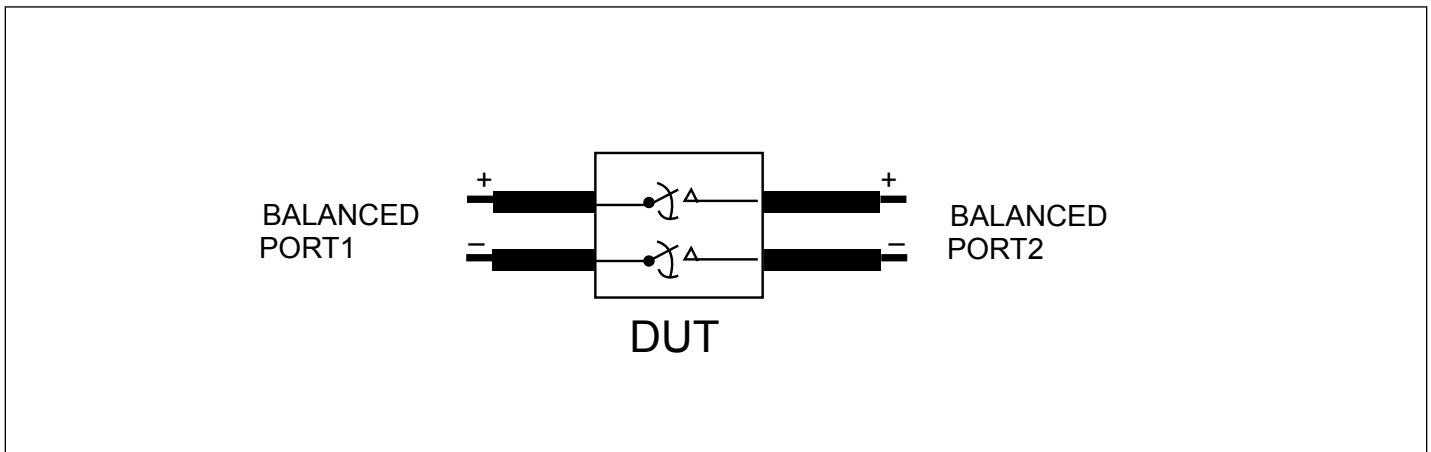
Parameter	Description	Min.	Typ.	Max.	Units
T <sub>pd</sub>	Propagation delay (input pin to output pin) on all channels		80		ps
t <sub>b-b</sub>	Bit-to-bit skew within the same differential pair of Dx± channels		5	7	ps
t <sub>ch-ch</sub>	Channel-to-channel skew of Dx± channels			35	ps
T <sub>sw a-b</sub>	time it takes to switch from port A to port B			0.1	us
T <sub>sw b-a</sub>	time it takes to switch from port B to port A			0.1	us
T <sub>startup</sub>	V <sub>DD</sub> valid to channel enable			10	us
T <sub>wakeup</sub>	Enabling output by changing OE from low to High			10	us



**Fig 1. Crosstalk Setup**



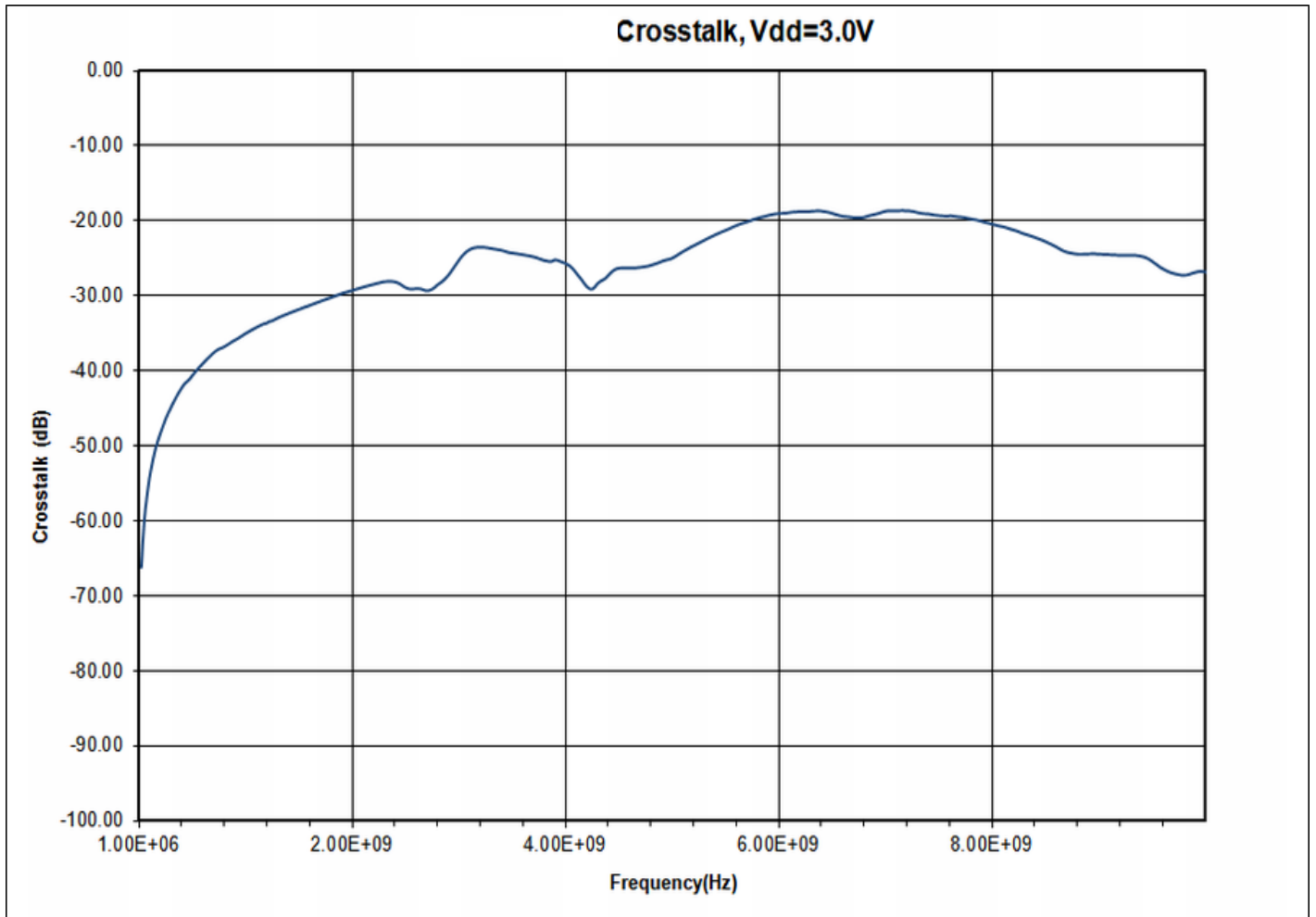
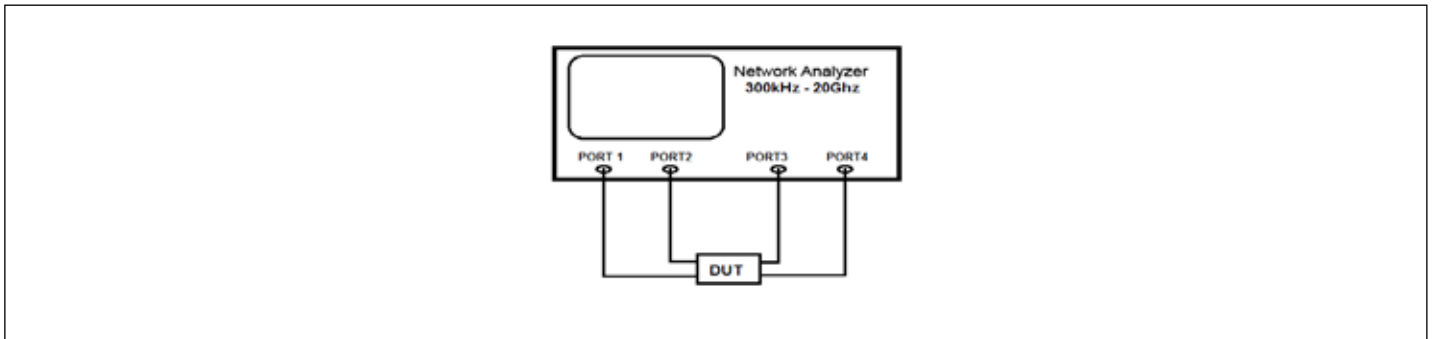
**Fig 2. Off-isolation setup**



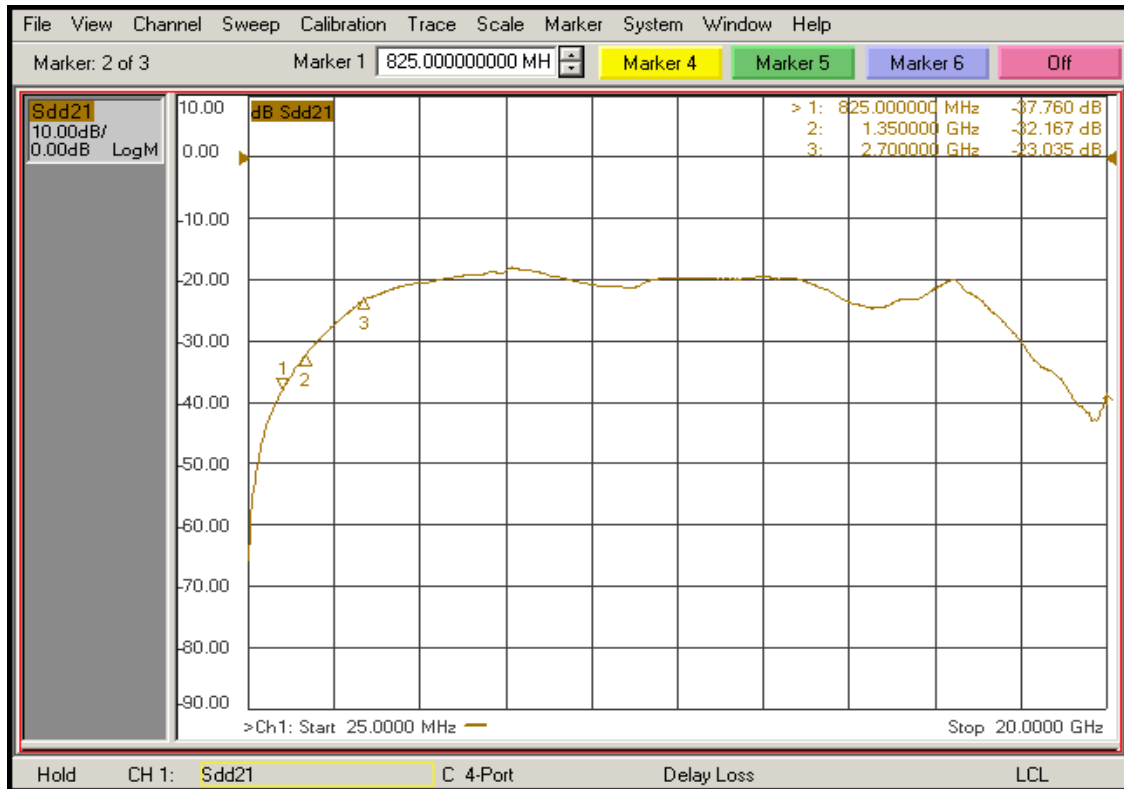
**Fig 3. Differential Insertion Loss**



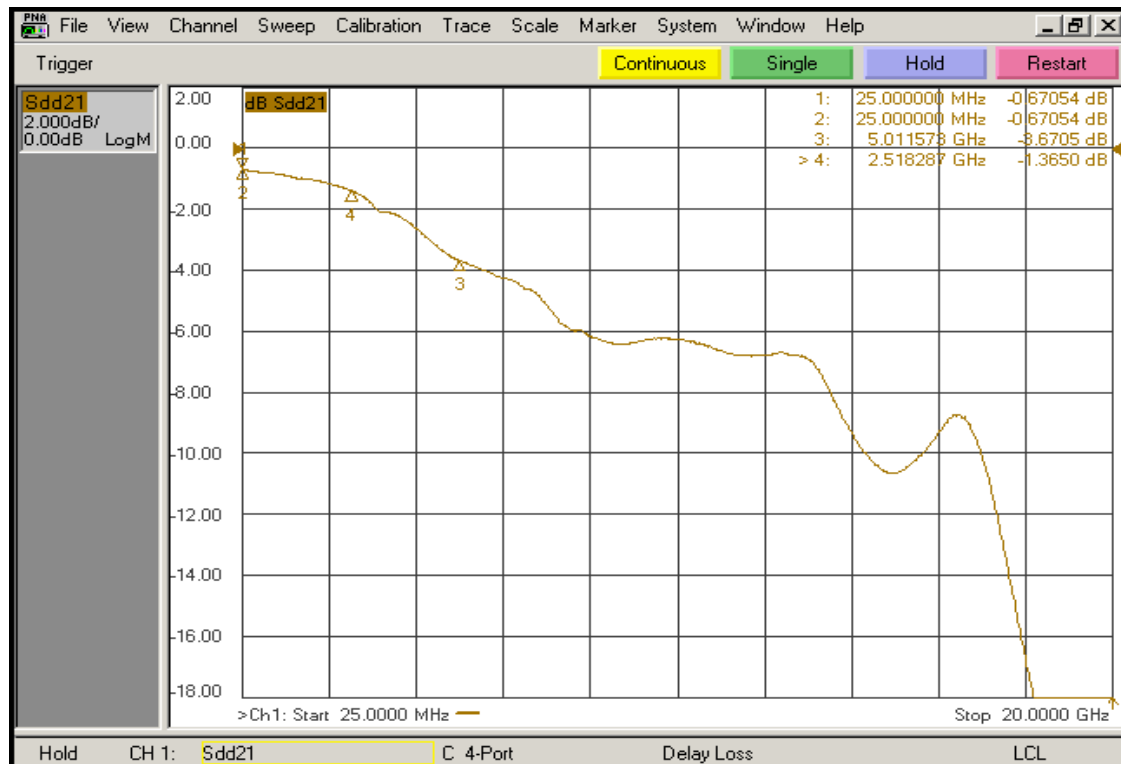
**Test Circuit for Dynamic Electrical Characteristics**



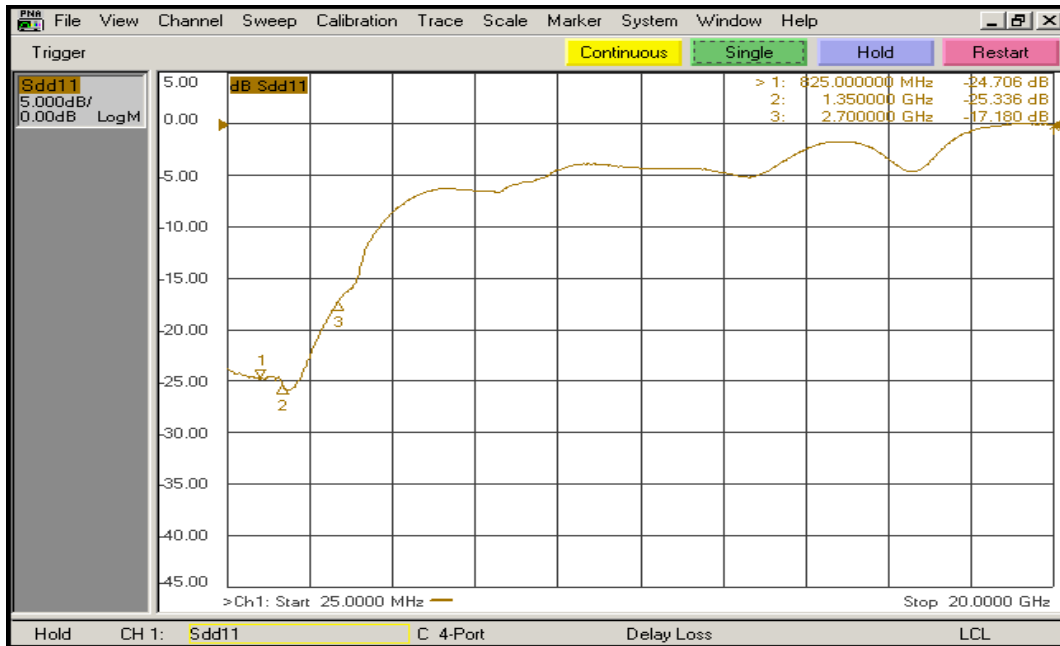
**Fig 4. Crosstalk**



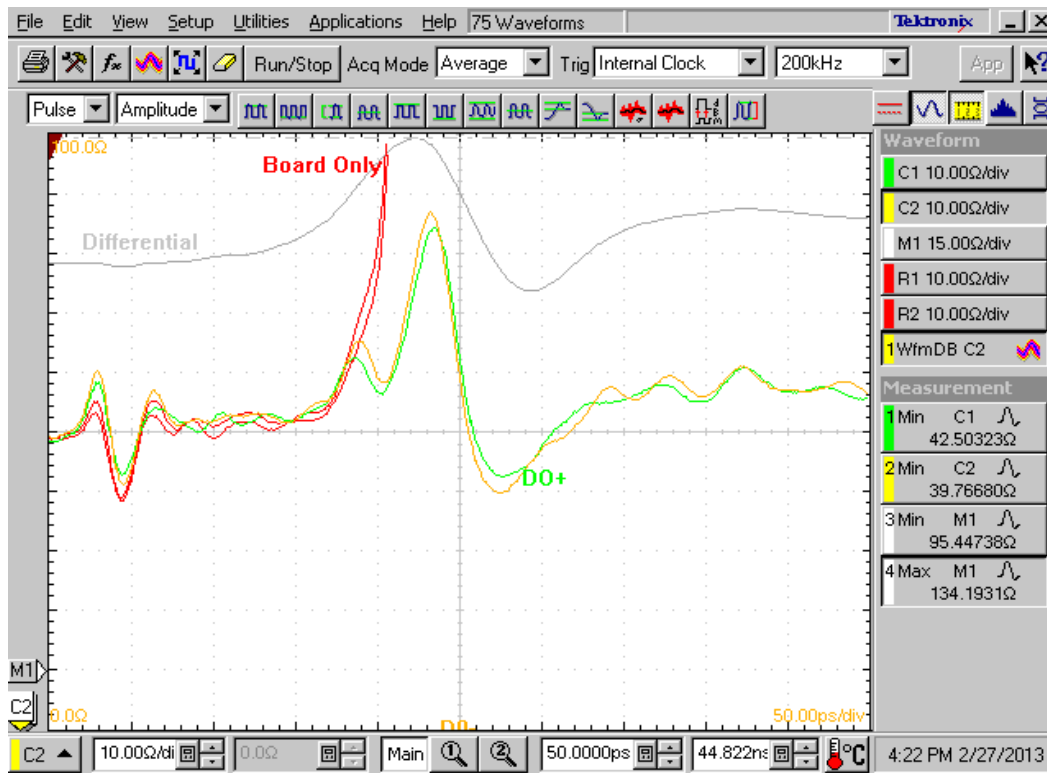
**Fig 5. Off Isolation**



**Fig 6. Insertion Loss**

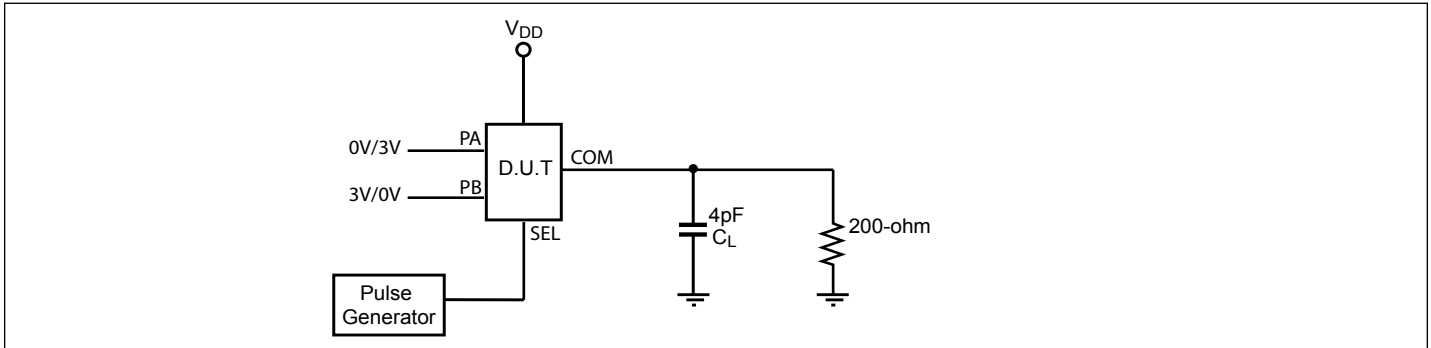


**Fig 7. Return Loss**



**Fig 8. TDR Channel D0, VDD=3.0V, 25C**

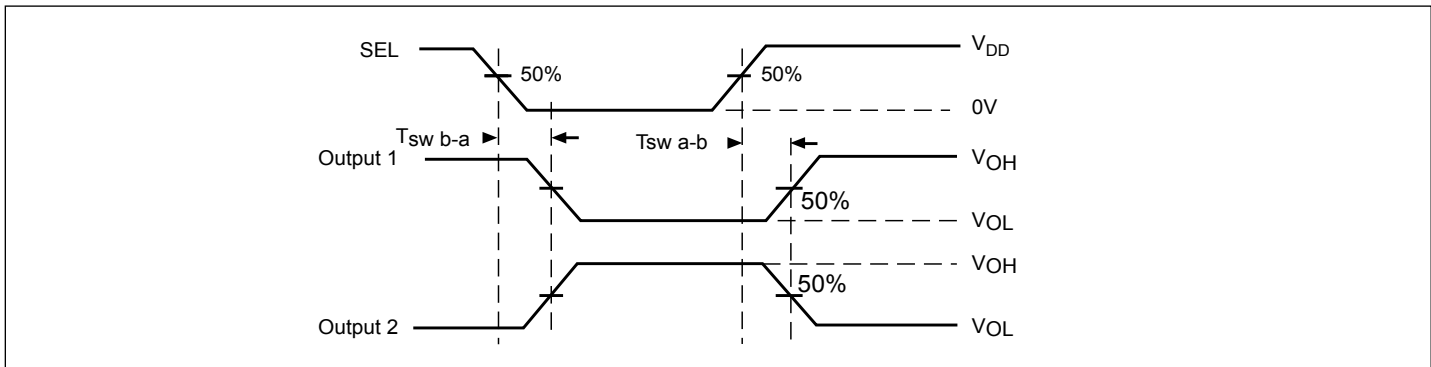
**Test Circuit for Electrical Characteristics(1-4)**



**Notes:**

1.  $C_L$  = Load capacitance: includes jig and probe capacitance.
2.  $R_T$  = Termination resistance: should be equal to  $Z_{OUT}$  of the Pulse Generator
3. All input impulses are supplied by generators having the following characteristics:  $PRR \leq \text{MHz}$ ,  $Z_O = 50\Omega$ ,  $t_R \leq 2.5\text{ns}$ ,  $t_F \leq 2.5\text{ns}$ .
4. The outputs are measured one at a time with one transition per measurement.

**Switching Waveforms**

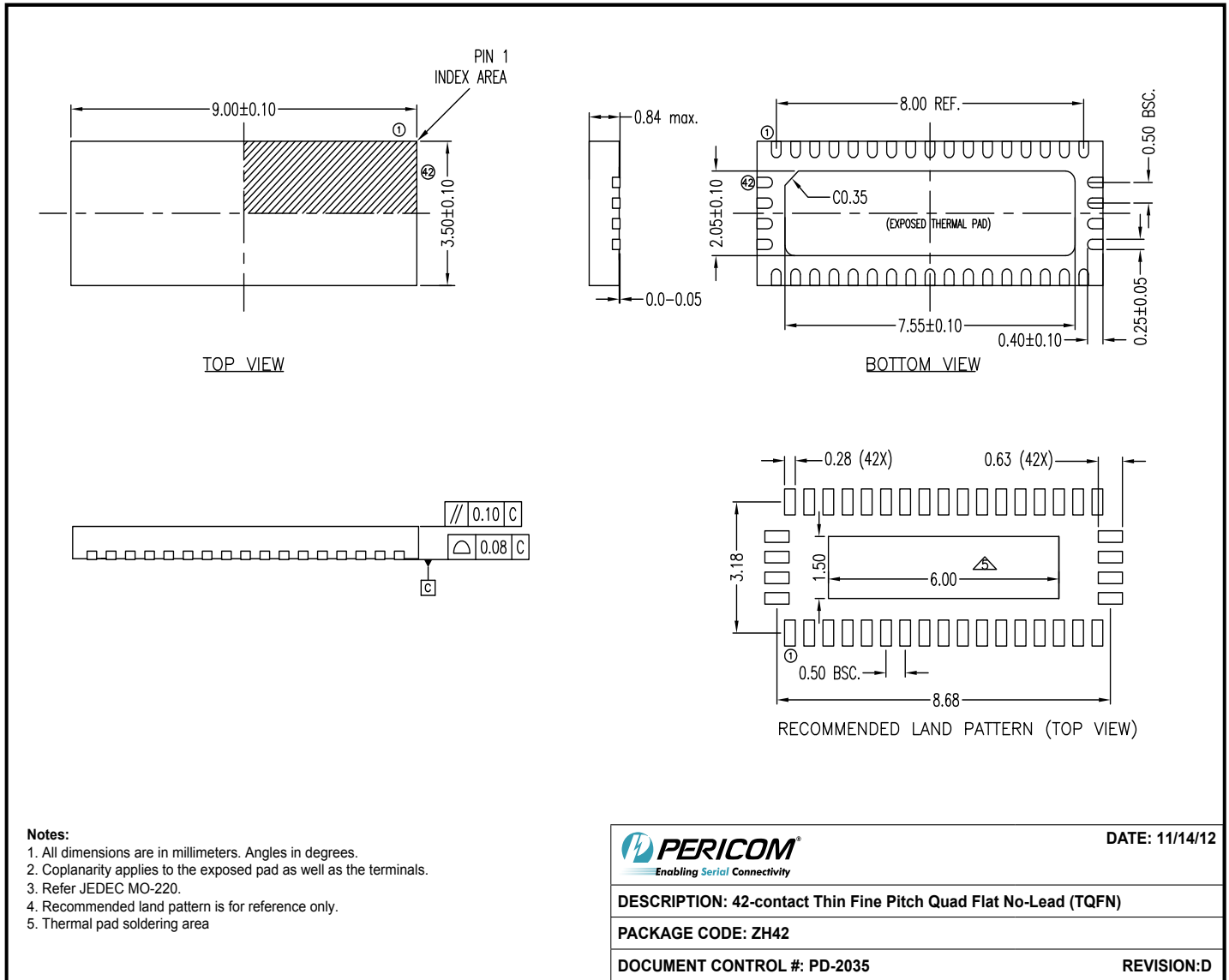


**Voltage Waveforms for Select Timing**

**Test Condition**

Output 1 Test Condition	Output 2 Test Condition
PA = Low	PA = High
PB = High	PB = Low

**Packaging Mechanical: 42ZH**



12-0529

**Note:**

For latest package info, please check: <http://www.pericom.com/products/packaging/mechanicals.php>

**Ordering Information**

Ordering Code	Package Code	Package Description
PI3WVR12412ZHE	ZH	42-contact, Thin Fine Pitch Quad Flat No-Lead (TQFN)

**Notes:**

- Thermal characteristics can be found on the company web site at [www.pericom.com/packaging/](http://www.pericom.com/packaging/)
- "E" denotes Pb-free and Green
- Adding an "X" at the end of the ordering code denotes tape and reel packaging