

1. Part No. Expression:

WAQ7FN110-RB-10

(a) (b) (c) (d) (e)(f) (g)

- (a) Series Code
- (b) Dimension Code
- (c) Material Code
- (d) Inductance Code
- (e) Packaging Code
- (f) Current Rating Code
- (g) Internal controlled number

2. Configuration & Dimensions

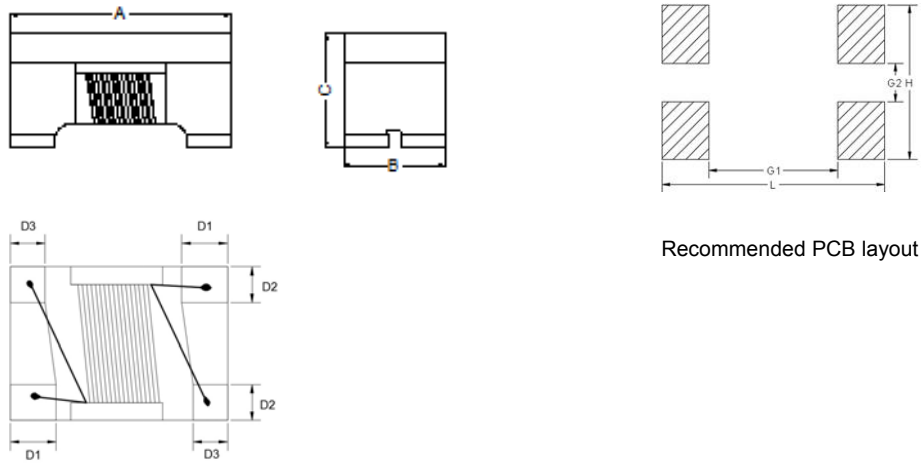

Unit: mm

A	B	C	D1	D2	D3	L	H	G1	G2
4.5±0.2	3.2±0.2	3.0 Max.	0.95±0.25	0.85±0.30	0.85±0.25	5.2	3.6	3.0	0.9

3. Schematic

Common mode

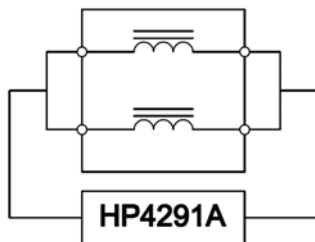

Differential mode

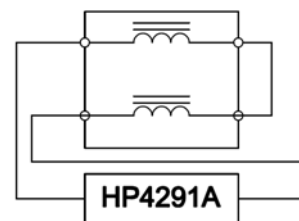

4. Material List

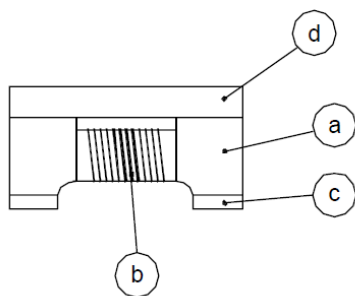

- (a) Core
- (b) Wire
- (c) Terminal
- (d) Upper Plate

5. General Specification

- (a) Operating Temp. : -55°C to +150°C
- (b) Storage Temp. : -55°C to +125°C (on board)
- (c) Humidity Range: 85 ± 3% RH
- (d) Storage Condition (Component in its packaging)
 - i) Temperature: Less than 40°C
 - ii) Humidity : 60% RH

6. Electrical Characteristics

Part Number	Common Mode Impedance (Ω)		Inductance (uH) 100kHz	DC Resistance (Ω) Max.	Rated Current (mA)	Rated Volt. (Vdc)	IR (Ω) Min.
	300 Min.	600 Typ.					
WAQ7FN110-RB-10	300 Min.	600 Typ.	11 +50/-30%	0.6	250	50	10
WAQ7FN220-RB-10	500 Min.	1200 Typ.	22 +50/-30%	1.0	200	50	10
WAQ7FN510-RB-10	1000 Min.	2800 Typ.	51 +50/-30%	1.0	200	50	10
WAQ7FN101-RA-10	2000 Min.	5800 Typ.	100 +50/-30%	2.0	150	50	10

7. Characteristics Curves

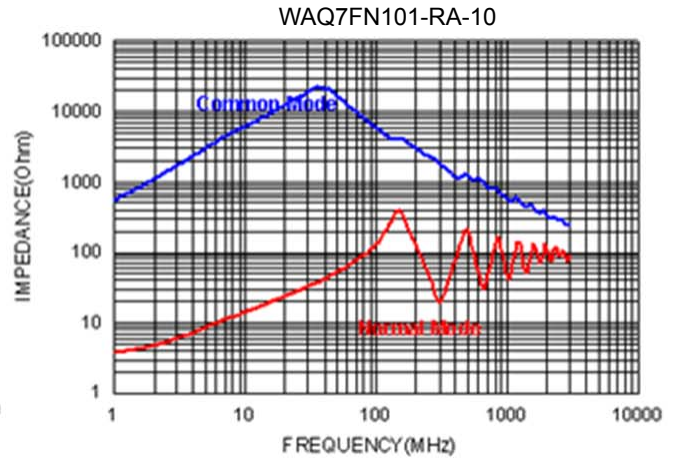
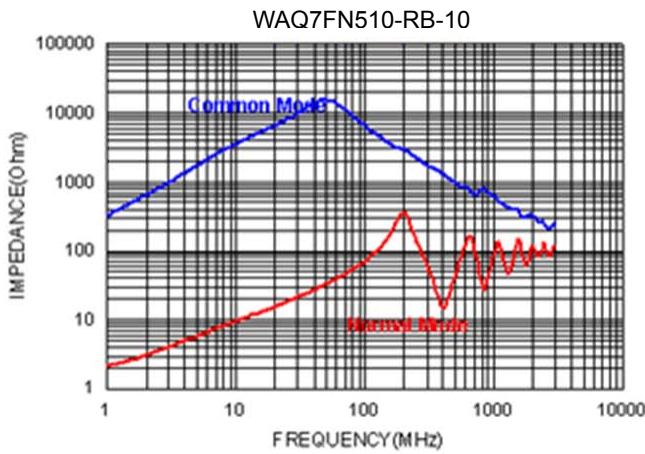
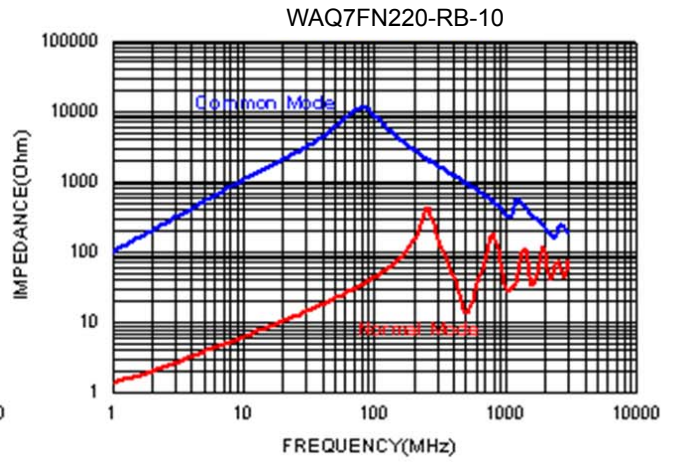
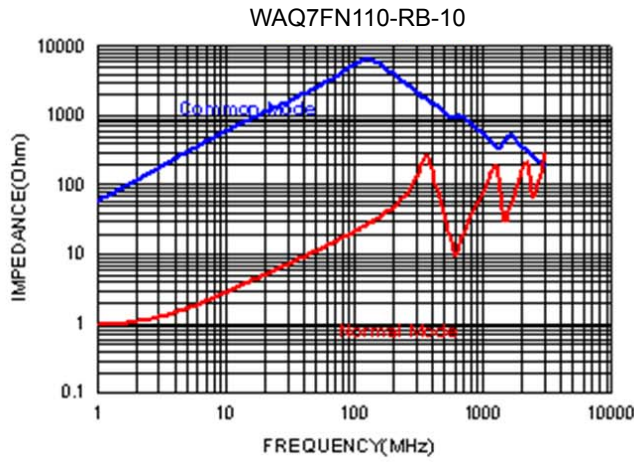

8. Soldering

Mildly activated rosin fluxes are preferred. Our terminations are suitable for all re-flow soldering systems. If hand soldering cannot be avoided, the preferred technique is the utilization of hot air soldering tools.

8-1 Solder Re-flow:

Recommended temperature profiles for re-flow soldering in Figure 1.

8-2 Soldering Iron (Figure 2):

Products attachment with soldering iron is discouraged due to the inherent process control limitations. In the event that a soldering iron must be employed the following precautions are recommended.

Note :

- Preheat circuit and products to 150°C.
- 355°C tip temperature (Max.)
- Never contact the ceramic with the iron tip
- 1.0mm tip diameter (Max.)
- Use a 20 watt soldering iron with tip diameter of 1.0mm
- Limit soldering time to 4~5 sec.

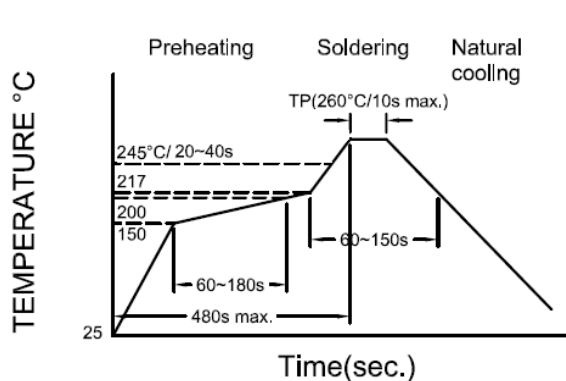

Figure 1 : Re-flow Soldering time
3 times Max.

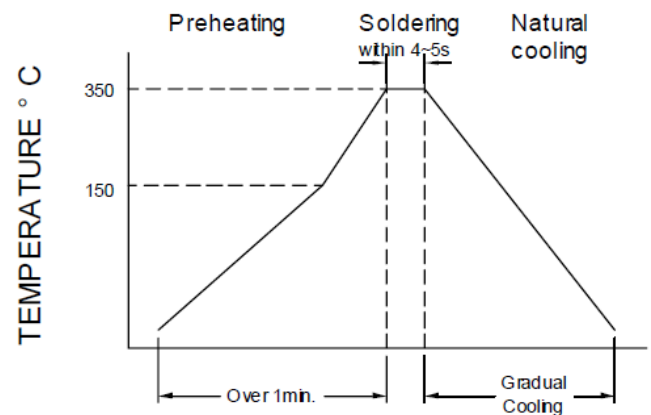
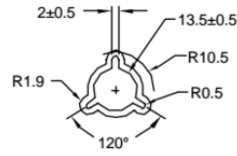
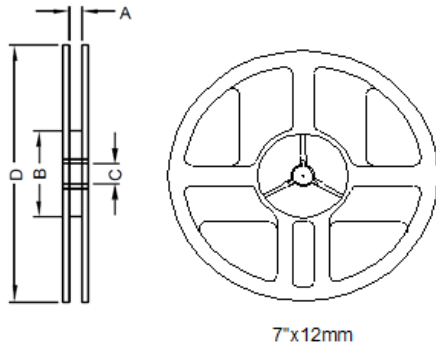

Figure 2 : Iron Soldering time
1 times Max.

9. Packaging Information:

9-1 Reel Dimension



Type	A(mm)	B(mm)	C(mm)	D(mm)
7"x12mm	13.5 ± 0.5	60.0 ± 2.0	13.5 ± 0.5	178.0 ± 2.0

9-2 Tape Dimension

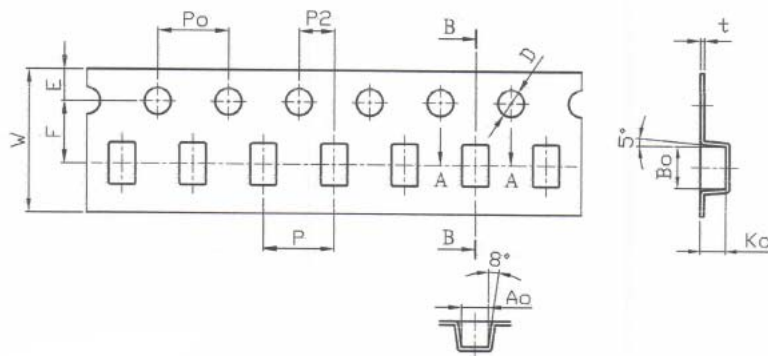

Size	W(mm)	P(mm)	E(mm)	F(mm)	P2(mm)	D(mm)	P0(mm)	A0(mm)	B0(mm)	K0(mm)	t(mm)
WAQ7FN	12.00±0.10	8.00±0.10	1.75±0.10	5.50±0.05	2.00±0.05	1.05+0.10/-0.00	4.00±0.10	3.60±0.10	4.90±0.10	3.00±0.10	0.26±0.05

9-3 Packaging Quantity

Chip Size	WAQ7FN
Chip/Reel	500
Inner Box	2,000
Middle Box	10,000
Carton	20,000

9-4 Tearing Off Force

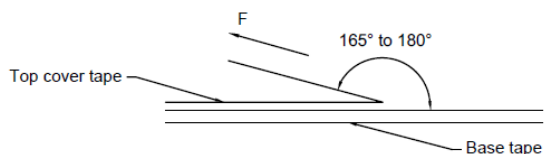

The force for tearing off cover tape is 15 to 80 grams in the arrow direction under the following conditions.

Room Temp. (°C)	Room Humidity (%)	Room atm (hPa)	Tearing Speed mm/min
5~35	45~85	860~1060	300

Application Notice:

1. Storage Conditions:

To maintain the solderability of terminal electrodes:

- a) Recommended products should be used within 12 months from the time of delivery.
- b) The packaging material should be kept where no chlorine or sulfur exists in the air.

2. Transportation:

- a) Products should be handled with care to avoid damage or contamination from perspiration and skin oils.
- b) Vacuum pick up is strongly recommended for individual components.
- c) Bulk handling should ensure that abrasion and mechanical shock are minimized.