



# IEEE 802.3af PD Interface and PWM Controllers with Integrated Power MOSFETs

## General Description

The MAX5953A/MAX5953B/MAX5953C/MAX5953D integrate a complete power IC solution for Powered Devices (PD) in a Power-Over-Ethernet (PoE) system, in compliance with the IEEE 802.3af standard. The MAX5953A/MAX5953B/MAX5953C/MAX5953D provide the PD with a detection signature, a classification signature, and an integrated isolation switch with programmable inrush current control. These devices also integrate a voltage-mode PWM controller with two power MOSFETs connected in a two-switch voltage-clamped DC-DC converter configuration.

An integrated MOSFET provides PD isolation during detection and classification. All devices guarantee a leakage current offset of less than 10 $\mu$ A during the detection phase. A programmable current limit prevents high inrush current during power-on. The devices feature power-mode undervoltage lockout (UVLO) with wide hysteresis and long deglitch time to compensate for twisted-pair-cable resistive drop and to assure glitch-free transition between detection, classification, and power-on/off phases. The MAX5953A/MAX5953C have an adjustable UVLO threshold with the default value compliant to the 802.3af standard, while the MAX5953B/MAX5953D have a lower and fixed UVLO threshold compatible with some legacy pre-802.3af power-sourcing equipment (PSE) devices.

The DC-DC converters are operable in either forward or flyback configurations with a wide input voltage range from 11V to 76V and up to 15W of output power. The voltage-clamped power topology enables full recovery of stored magnetizing and leakage inductive energy for enhanced efficiency and reliability. When using the high-side MOSFET, the controller can be configured as a buck converter. A look-ahead signal for driving secondary-side synchronous rectifiers can be used to increase efficiency. A wide array of protection features include UVLO, over-temperature shutdown, and short-circuit protection with hiccup current limit for enhanced performance and reliability. Operation up to 500kHz allows for smaller external magnetics and capacitors.

The MAX5953A/MAX5953B/MAX5953C/MAX5953D are available in a high-power (2.22W), 7mm x 7mm thermally enhanced thin QFN package.

## Applications

IEEE 802.3af Powered Devices	Internet Appliances
IP Phones	Security Cameras
Wireless Access Nodes	Computer Telephony

## Features

- ◆ **Powered Device Interface**
  - Fully Integrated IEEE 802.3af-Compliant PD Interface
  - PD Detection and Programmable Classification Signatures
  - Less than 10 $\mu$ A Leakage Current Offset During Detection
  - Integrated MOSFET for Isolation and Inrush Current Limiting
  - Gate Output Allows External Control of the Internal Isolation MOSFET
  - Programmable Inrush Current Control
  - Programmable Undervoltage Lockout (MAX5953A/MAX5953C)
- ◆ **DC-DC Converter**
  - Clamped, Two-Switch Power IC for High Efficiency
  - Integrated High-Voltage 0.4 $\Omega$  Power MOSFETs
  - Up to 15W Output Power
  - Bias Voltage Regulator with Automatic High-Voltage Supply Turn-Off
  - 11V to 76V Wide Input Voltage Range
  - Feed-Forward Voltage-Mode Control for Fast Input Transient Rejection
  - Programmable Undervoltage Lockout
  - Overtemperature Shutdown
  - Indefinite Short-Circuit Protection with Programmable Fault Integration
  - Integrated Look-Ahead Signal for Secondary-Side Synchronous Rectification
  - > 90% Efficiency with Synchronous Rectification
  - Up to 500kHz Switching Frequency
- ◆ **High-Power (2.22W), 7mm x 7mm Thermally Enhanced Lead-Free Thin QFN Package**

## Ordering Information

PART	PIN-PACKAGE	PKG CODE
MAX5953AUTM+	48 TQFN	T4877-6
MAX5953BUTM+	48 TQFN	T4877-6
MAX5953CUTM+	48 TQFN	T4877-6
MAX5953DUTM+	48 TQFN	T4877-6

Operating junction temperature range is 0°C to +125°C.  
+Denotes lead-free package.

Pin Configuration and Typical Operating Circuit appear at end of data sheet.



For pricing, delivery, and ordering information, please contact Maxim/Dallas Direct! at 1-888-629-4642, or visit Maxim's website at [www.maxim-ic.com](http://www.maxim-ic.com).

MAX5953A/MAX5953B/MAX5953C/MAX5953D

# IEEE 802.3af PD Interface and PWM Controllers with Integrated Power MOSFETs

## ABSOLUTE MAXIMUM RATINGS

V+ to VEE	-0.3V to +90V
OUT, PGOOD, PGOOD to VEE	-0.3V to (V+ + 0.3V)
RCLASS, GATE to VEE	-0.3V to +12V
UVLO to VEE	-0.3V to +8V
PGOOD to OUT	-0.3V to (V+ + 0.3V)
HVIN, INBIAS, DRNH, XFRMRH, XFRMRL to GND	-0.3V to +80V
BST to GND	-0.3V to +95V
BST to XFRMRH	-0.3V to +12V
PGND to GND	-0.3V to +0.3V
DCUVLO, RAMP, CSS, OPTO, FLTINT, RCFF, RTCT to GND	-0.3V to +12V
SRC, CS to GND	-0.3V to +6V
REGOUT, DRVIN to GND	-0.3V to +12V
REGOUT to HVIN	-80V to +0.3V
REGOUT to INBIAS	-80V to +0.3V
PPWM to GND	-0.3V to (VREGOUT + 0.3V)

Maximum Input/Output Current (Continuous)	
OUT to VEE	500mA
V+, RCLASS to VEE	70mA
UVLO, PGOOD, PGOOD to VEE	20mA
GATE to VEE	80mA
REGOUT to GND	50mA
DRNH, XFRMRH, XFRMRL, SRC to GND (Average), TJ = +125°C	0.9A
PPWM to GND	±20mA
Continuous Power Dissipation* (TA = +70°C)	
48-Pin TQFN 7mm X 7mm (derate 27.8mW/°C above +70°C)	2222mW
θJA	36°C/W
Operating Ambient Temperature Range	0°C to +85°C
Operating Junction Temperature Range	0°C to +125°C
Junction Temperature	+150°C
Storage Temperature Range	-60°C to +150°C
Lead Temperature (soldering, 10s)	+300°C

\*As per JEDEC 51 standard.

Stresses beyond those listed under "Absolute Maximum Ratings" may cause permanent damage to the device. These are stress ratings only, and functional operation of the device at these or any other conditions beyond those indicated in the operational sections of the specifications is not implied. Exposure to absolute maximum rating conditions for extended periods may affect device reliability.

## ELECTRICAL CHARACTERISTICS

(VIN = (V+ - VEE) = 48V, GATE = PGOOD = PGOOD = unconnected, GND = OUT, HVIN = V+, UVLO = VEE, TJ = 0°C to +125°C, unless otherwise noted. Typical values are at TJ = +25°C. All voltages are referenced to VEE, unless otherwise noted.) (Note 1)

PARAMETER	SYMBOL	CONDITIONS	MIN	TYP	MAX	UNITS	
<b>POWERED DEVICE (PD) INTERFACE</b>							
<b>DETECTION MODE</b>							
Input Offset Current	I <sub>OFFSET</sub>	V <sub>IN</sub> = 1.4V to 10.1V (Note 2)			10	μA	
Effective Differential Input Resistance (Note 3)	dR	V <sub>IN</sub> = 1.4V, up to 10.1V with 1V step	550			kΩ	
<b>CLASSIFICATION MODE</b>							
Classification Current Turn-Off Threshold	V <sub>TH,CLASS</sub>	V <sub>IN</sub> rising (Note 4)	20.8	21.8	22.5	V	
Classification Current	I <sub>CLASS</sub>	V <sub>IN</sub> = 12.6V to 20V, R <sub>DISC</sub> = 25.5kΩ (Notes 5, 6)	Class 0, R <sub>RCLASS</sub> = 10kΩ	0		2	mA
			Class 1, R <sub>RCLASS</sub> = 732Ω	9.17		11.83	
			Class 2, R <sub>RCLASS</sub> = 392Ω	17.29		19.71	
			Class 3, R <sub>RCLASS</sub> = 255Ω	26.45		29.55	
			Class 4, R <sub>RCLASS</sub> = 178Ω	36.6		41.4	
<b>POWER MODE</b>							
Operating Supply Voltage	V <sub>IN</sub>	V <sub>IN</sub> = (V+ - VEE)			67	V	
Operating Supply Current	I <sub>IN</sub>	Measure at V+, not including R <sub>DISC</sub> , GATE = VEE, HVIN = GND = OUT		0.4	1	mA	
Default Power Turn-On Voltage	V <sub>UVLO,ON</sub>	V <sub>IN</sub> increasing	MAX5953A/MAX5953C	37.4	38.6	40.2	V
			MAX5953B/MAX5953D	34.3	35.4	36.9	
Default Power Turn-Off Voltage	V <sub>UVLO,OFF</sub>	V <sub>IN</sub> decreasing, MAX5953A/MAX5953C	30			V	

# IEEE 802.3af PD Interface and PWM Controllers with Integrated Power MOSFETs

MAX5953A/MAX5953B/MAX5953C/MAX5953D

## ELECTRICAL CHARACTERISTICS (continued)

( $V_{IN} = (V_{+} - V_{EE}) = 48V$ , GATE = PGOOD =  $\overline{\text{PGOOD}}$  = unconnected, GND = OUT, HVIN =  $V_{+}$ , UVLO =  $V_{EE}$ ,  $T_J = 0^{\circ}\text{C}$  to  $+125^{\circ}\text{C}$ , unless otherwise noted. Typical values are at  $T_J = +25^{\circ}\text{C}$ . All voltages are referenced to  $V_{EE}$ , unless otherwise noted.) (Note 1)

PARAMETER	SYMBOL	CONDITIONS	MIN	TYP	MAX	UNITS
Default Power Turn-On/Off Hysteresis Voltage	$V_{\text{HYST,UVLO}}$	MAX5953A/MAX5953C	7.1			V
		MAX5953B/MAX5953D	4			
External UVLO Programming Range	$V_{\text{IN,EX}}$	MAX5953A/MAX5953C only (Note 7)	12		67	V
UVLO External Reference Voltage	$V_{\text{REF,UVLO}}$	$V_{\text{UVLO}}$ increasing	2.400	2.460	2.522	V
UVLO External Reference Voltage Hysteresis	$V_{\text{HYST,UVLO}}$	Ratio to $V_{\text{REF,UVLO}}$	19.2	20	20.9	%
UVLO Bias Current	$I_{\text{IN,UVLO}}$	$V_{\text{UVLO}} = 2.460V$	-1.5		+1.5	$\mu\text{A}$
UVLO Input Ground-Sense Threshold	$V_{\text{TH,G,UVLO}}$	(Note 8)	50		440	mV
UVLO Input Ground-Sense Glitch Rejection				7		$\mu\text{s}$
Power Turn-Off Voltage, Undervoltage Lockout Deglitch Time	$t_{\text{OFF,DLY}}$	$V_{\text{IN}}$ , $V_{\text{UVLO}}$ falling (Note 9)	0.32			ms
Isolation Switch n-Channel MOSFET On-Resistance	$R_{\text{ON,ISO}}$	Output current = 300mA, $V_{\text{GATE}} = 5.6V$ , measured between OUT and $V_{EE}$		0.6	1.5	$\Omega$
Isolation Switch n-Channel MOSFET Off-Threshold Voltage	$V_{\text{GSTH}}$	$V_{\text{GATE}} - V_{EE}$ , OUT = $V_{+}$ , output current < $1\mu\text{A}$	0.5			V
GATE Pulldown Switch Resistance	$R_{\text{G}}$	Power-off mode, $V_{\text{IN}} = +12V$		38	80	$\Omega$
GATE Charging Current	$I_{\text{GATE}}$	$V_{\text{GATE}} = 2V$	4.5	10	16.5	$\mu\text{A}$
GATE High Voltage	$V_{\text{GATE}}$	$I_{\text{GATE}} = 1\mu\text{A}$	5.59	5.76	5.93	V
PGOOD Assertion $V_{\text{OUT}}$ Threshold (Note 10)	$V_{\text{OUTEN}}$	$V_{\text{OUT}} - V_{EE}$ decreasing, $V_{\text{GATE}} = 5.75V$	1.16	1.23	1.31	V
		Hysteresis		70		mV
PGOOD, $\overline{\text{PGOOD}}$ Assertion $V_{\text{GATE}}$ Threshold	$V_{\text{GSEN}}$	$V_{\text{GATE}} - V_{EE}$ increasing	4.62	4.76	4.91	V
		Hysteresis		80		mV
PGOOD, $\overline{\text{PGOOD}}$ Output Low Voltage	$V_{\text{OL,PGOOD}}$	$I_{\text{SINK}} = 2\text{mA}$ , $V_{\text{OUT}} \leq (V_{+} - 5V)$ (Note 11)			0.2	V
PGOOD Leakage Current		GATE = high, $V_{+} - V_{\text{OUT}} = 67V$ (Note 11)			1	$\mu\text{A}$
$\overline{\text{PGOOD}}$ Leakage Current		GATE = $V_{EE}$ , $\overline{\text{PGOOD}} - V_{EE} = 67V$ (Note 11)			1	$\mu\text{A}$

# IEEE 802.3af PD Interface and PWM Controllers with Integrated Power MOSFETs

## ELECTRICAL CHARACTERISTICS (DC-DC Controller)

(All voltages referenced to GND, unless otherwise noted.  $V_{HVIN} = +48V$ ,  $C_{INBIAS} = 1\mu F$ ,  $C_{REGOUT} = 2.2\mu F$ ,  $R_{RTCT} = 25k\Omega$ ,  $C_{RTCT} = 100pF$ ,  $C_{BST} = 0.22\mu F$ ,  $V_{CSS} = V_{CS} = 0V$ ,  $V_{RAMP} = V_{DCUVLO} = 3V$ ,  $T_J = 0^\circ C$  to  $+125^\circ C$ , unless otherwise noted. Typical values are at  $T_J = +25^\circ C$ , unless otherwise noted.) (Note 1)

PARAMETER	SYMBOL	CONDITIONS	MIN	TYP	MAX	UNITS
Input Supply Range	$V_{HVIN}$		11		76	V
<b>OSCILLATOR (RTCT)</b>						
PWM Frequency	$f_S$			250		kHz
Maximum PWM Duty Cycle	$D_{MAX}$			47		%
Maximum RTCT Frequency	$f_{RTCTMAX}$	(Note 12)		1		MHz
RTCT Peak Trip Level	$V_{TH,RTCT}$		0.51 x $V_{REGOUT}$			V
RTCT Valley Trip Level	$V_{TL,RTCT}$		1			V
RTCT Input Bias Current	$I_{IN,RTCT}$		$\pm 1$			$\mu A$
RTCT Discharge MOSFET $R_{DS(ON)}$	$R_{DIS,RTCT}$	Sinking 50mA		35	85	$\Omega$
RTCT Discharge Pulse Width			50			ns
<b>LOOK-AHEAD LOGIC (PPWM)</b>						
PPWM to Output Propagation Delay	$t_{PPWM}$	$V_{PPWM}$ rising to $V_{XFRMRL}$ falling		110		ns
PPWM Output High	$V_{OH,PPWM}$	Sourcing 2mA	7.0		11.0	V
PPWM Output Low	$V_{OL,PPWM}$	Sinking 2mA			0.2	V
<b>PWM COMPARATOR (OPTO, RAMP, RCFF)</b>						
Common-Mode Input Range	$V_{CM\_PWM}$		0		5.5	V
Input Offset Voltage			10			mV
Input Bias Current			-2		+2	$\mu A$
RAMP to XFRMRL Propagation Delay	$t_{COMPARATOR}$	From $V_{RAMP}$ (50mV overdrive) rising to $V_{XFRMRL}$ rising		100		ns
Minimum OPTO Voltage		$V_{CSS} = 0V$ , OPTO sinking 2mA	1.47			V
Minimum RCFF Voltage		RCFF sinking 2mA	2.18			V
<b>REGOUT LDO (REGOUT)</b>						
REGOUT Voltage Set Point	$V_{REGOUT}$	INBIAS unconnected, $V_{HVIN} = 11V$ to $76V$	8.3	8.75	9.2	V
		$V_{INBIAS} = V_{HVIN} = 11V$ to $76V$	9.5	10.6	11.0	
REGOUT Load Regulation		INBIAS unconnected, $V_{HVIN} = 15V$ , $I_{REGOUT} = 0$ to $30mA$	0.25			V
		$V_{INBIAS} = V_{HVIN} = 15V$ , $I_{REGOUT} = 0$ to $30mA$	0.25			
REGOUT Dropout Voltage		INBIAS unconnected, $I_{REGOUT} = 30mA$	1.25			V
		$V_{INBIAS} = V_{HVIN}$ , $I_{REGOUT} = 30mA$	1.25			
REGOUT Undervoltage Lockout Threshold		REGOUT rising	6.6	7.0	7.4	V
REGOUT Undervoltage Lockout Threshold Hysteresis		REGOUT falling	0.7			V

# IEEE 802.3af PD Interface and PWM Controllers with Integrated Power MOSFETs

MAX5953A/MAX5953B/MAX5953C/MAX5953D

## ELECTRICAL CHARACTERISTICS (DC-DC Controller) (continued)

(All voltages referenced to GND, unless otherwise noted.  $V_{HVIN} = +48V$ ,  $C_{INBIAS} = 1\mu F$ ,  $C_{REGOUT} = 2.2\mu F$ ,  $R_{RTCT} = 25k\Omega$ ,  $C_{RTCT} = 100pF$ ,  $C_{BST} = 0.22\mu F$ ,  $V_{CSS} = V_{CS} = 0V$ ,  $V_{RAMP} = V_{DCUVLO} = 3V$ ,  $T_J = 0^\circ C$  to  $+125^\circ C$ , unless otherwise noted. Typical values are at  $T_J = +25^\circ C$ , unless otherwise noted.) (Note 1)

PARAMETER	SYMBOL	CONDITIONS	MIN	TYP	MAX	UNITS
<b>SOFT-START (CSS)</b>						
Soft-Start Current	$I_{CSS}$	$V_{CSS} = 0V$		33		$\mu A$
<b>INTEGRATING FAULT PROTECTION</b>						
FLTINT Source Current	$I_{FLTINT}$			80		$\mu A$
FLTINT Trip Point		$V_{FLTINT}$ rising		2.7		V
FLTINT Hysteresis				0.75		V
<b>INTERNAL POWER FETs</b>						
On-Resistance	$R_{ON,POWER}$	$V_{DRVIN} = V_{BST} = 9V$ , $V_{XFRMRH} = V_{SRC} = 0V$ , $I_{DS} = 50mA$		0.4	0.8	$\Omega$
Off-State Leakage Current			-5		+10	$\mu A$
Total Gate Charge Per Power FET				15		nC
<b>HIGH-SIDE DRIVER</b>						
Low to High Latency	$t_{LH-HS}$	Driver delay until FET $V_{GS}$ reaches $0.9 \times (V_{BST} - V_{XFRMRH})$ and is fully on		80		ns
High to Low Latency	$t_{HL-HS}$	Driver delay until FET $V_{GS}$ reaches $0.1 \times (V_{BST} - V_{XFRMRH})$ and is fully off		40		ns
Output Drive Voltage	$V_{BST}$	BST to XFRMRH with high side on		8		V
<b>LOW-SIDE DRIVER</b>						
Low to High Latency	$t_{LH-LS}$	Driver delay until FET $V_{GS}$ reaches $0.9 \times V_{DRVIN}$ and is fully on		80		ns
High to Low Latency	$t_{HL-LS}$	Driver delay until FET $V_{GS}$ reaches $0.1 \times V_{DRVIN}$ and is fully off		40		ns
<b>CURRENT-LIMIT COMPARATOR (CS)</b>						
Current-Limit Threshold Voltage	$V_{ILIM}$		140	156	172	mV
Current-Limit Input Bias Current	$I_{BILIM}$	$0 < V_{CS} < 0.3V$	-2		+2	$\mu A$
Propagation Delay to XFRMRL	$t_{dILIM}$	From $V_{CS}$ rising (10mV overdrive) to $V_{XFRMRL}$ rising		160		ns
<b>BOOST VOLTAGE CIRCUIT (See Figure 9, QB)</b>						
Driver Output Delay	$t_{PPWMD}$			200		ns
One-Shot Pulse Width	$t_{PWQB}$			300		ns
QB $R_{DS(on)}$		Sinking 20mA		30	60	$\Omega$
<b>THERMAL SHUTDOWN</b>						
Shutdown Temperature	$T_{SH}$	Temperature rising		+160		$^\circ C$
Thermal Hysteresis	$T_H$			20		$^\circ C$

# IEEE 802.3af PD Interface and PWM Controllers with Integrated Power MOSFETs

## ELECTRICAL CHARACTERISTICS (DC-DC Controller) (continued)

(All voltages referenced to GND, unless otherwise noted.  $V_{HVIN} = +48V$ ,  $C_{INBIAS} = 1\mu F$ ,  $C_{REGOUT} = 2.2\mu F$ ,  $R_{RTCT} = 25k\Omega$ ,  $C_{RTCT} = 100pF$ ,  $C_{BST} = 0.22\mu F$ ,  $V_{CSS} = V_{CS} = 0V$ ,  $V_{RAMP} = V_{DCUVLO} = 3V$ ,  $T_J = 0^\circ C$  to  $+125^\circ C$ , unless otherwise noted. Typical values are at  $T_J = +25^\circ C$ , unless otherwise noted.) (Note 1)

PARAMETER	SYMBOL	CONDITIONS	MIN	TYP	MAX	UNITS
<b>UNDERVOLTAGE LOCKOUT (DCUVLO)</b>						
Threshold Voltage	$V_{REF,DCUVLO}$	$V_{DCUVLO}$ rising	1.14	1.26	1.38	V
Hysteresis	$V_{HYS,DCUVLO}$			140		mV
Input Bias Current	$I_{IN,DCUVLO}$	$V_{DCUVLO} = 3V$	-100		+100	nA
<b>SUPPLY CURRENT</b>						
Supply Current		From $V_{HVIN} = 11V$ to $76V$ , $V_{CSS} = 0V$ , $V_{INBIAS} = 11V$		0.7	1.5	mA
		From $V_{INBIAS} = 11V$ to $76V$ , $V_{CSS} = 0V$ , $V_{HVIN} = 76V$		4.4	6.4	
		From $V_{HVIN} = 76V$ , $V_{OPIO} = 4V$		7		
Standby Supply Current		$V_{DCUVLO} = 0V$			1	mA

- Note 1:** Limits at  $0^\circ C$  are guaranteed by design, unless otherwise noted.
- Note 2:** The input offset current is illustrated in Figure 1.
- Note 3:** Effective differential input resistance is defined as the differential resistance between  $V_+$  and  $V_{EE}$  without any external resistance.
- Note 4:** Classification current is turned off whenever the IC is in power mode.
- Note 5:** See Table 2 in the *Classification Mode* section.  $R_{DISC}$  and  $R_{RCLASS}$  must be 1%, 100ppm or better.  $I_{CLASS}$  includes the IC bias current and the current drawn by  $R_{DISC}$ .
- Note 6:** See the *Thermal Dissipation* section.
- Note 7:** When UVLO is connected to the midpoint of an external resistor-divider with a series resistance of  $25.5k\Omega (\pm 1\%)$ , the turn-on threshold set point for the power mode is defined by the external resistor-divider. Make sure the voltage on UVLO does not exceed its maximum rating of 8V when  $V_{IN}$  is at the maximum voltage.
- Note 8:** When  $V_{UVLO}$  is below  $V_{TH,G,UVLO}$ , the MAX5953A/MAX5953C set the turn-on voltage threshold internally ( $V_{UVLO,ON}$ ).
- Note 9:** An input voltage or  $V_{UVLO}$  glitch below their respective thresholds shorter than or equal to  $t_{OFF\_DLY}$  does not cause the MAX5953A/MAX5953B/MAX5953C/MAX5953D to exit power-on mode (as long as the input voltage remains above an operable voltage level of 12V).
- Note 10:** Guaranteed by design, not tested in production for MAX5953B/MAX5953D.
- Note 11:** PGOOD references to OUT while  $\overline{PGOOD}$  references to  $V_{EE}$ .
- Note 12:** Output switching frequency is  $1/2$  oscillator frequency.

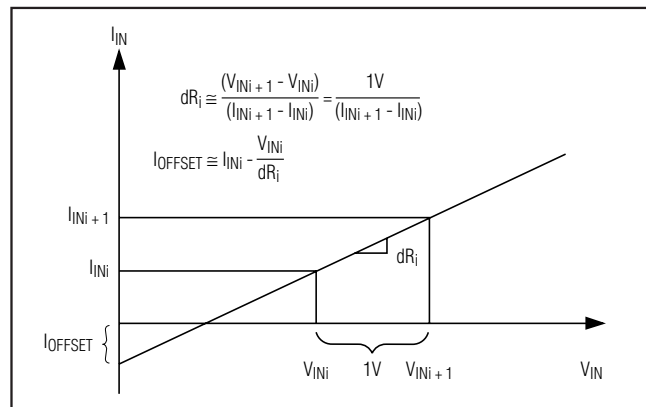

Figure 1. Effective Differential Input Resistance/Offset Current

# IEEE 802.3af PD Interface and PWM Controllers with Integrated Power MOSFETs

## Typical Operating Characteristics

( $V_{IN} = (V+ - V_{EE}) = 48V$ , GATE = PGOOD = unconnected, GND connected to OUT, HVIN connected to  $V+$ ,  $UVLO = V_{EE}$ ,  $C_{INBIAS} = 1\mu F$ ,  $C_{REGOUT} = 2.2\mu F$ ,  $R_{RTCT} = 25k\Omega$ ,  $C_{RTCT} = 100pF$ ,  $C_{BST} = 0.22\mu F$ ,  $T_J = 0^\circ C$  to  $+125^\circ C$ , unless otherwise noted. Typical values are at  $T_J = +25^\circ C$ . All voltages are referenced to  $V_{EE}$ , unless otherwise noted.)

**DETECTION CURRENT vs. INPUT VOLTAGE**

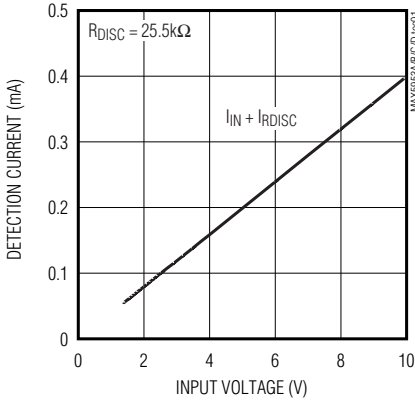

**CLASSIFICATION CURRENT vs. INPUT VOLTAGE**

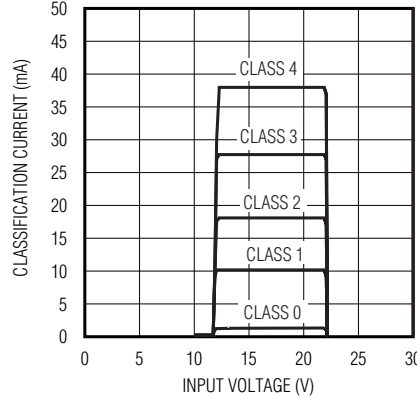

**EFFECTIVE DIFFERENTIAL INPUT RESISTANCE vs. INPUT CURRENT**

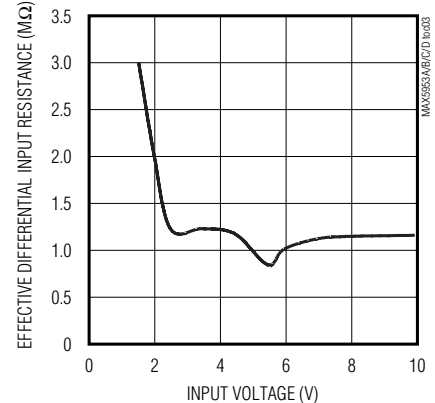

**INPUT OFFSET CURRENT vs. INPUT VOLTAGE**

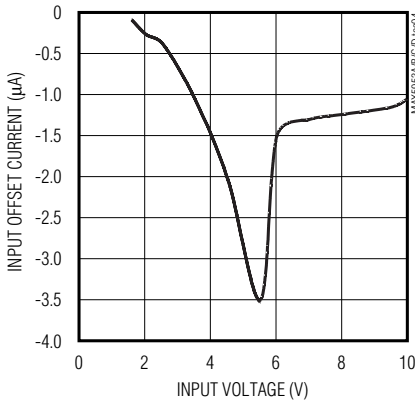

**NORMALIZED UVLO vs. TEMPERATURE**

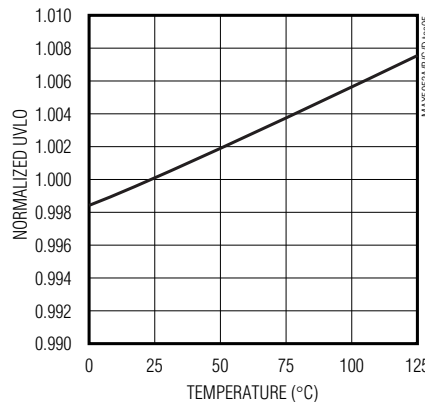

**PGOOD OUTPUT LOW VOLTAGE vs. CURRENT**

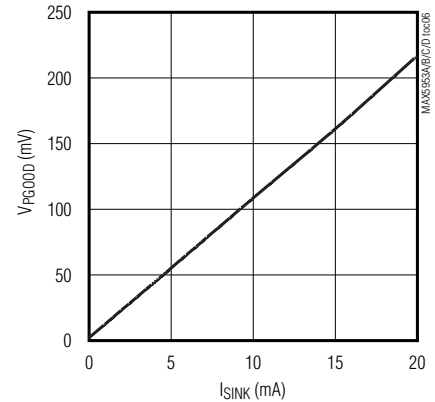

**OUT LEAKAGE CURRENT vs. TEMPERATURE**

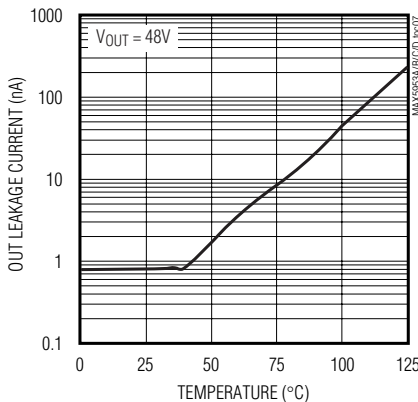

**INRUSH CURRENT CONTROL ( $V_{IN} = 48V$ )**

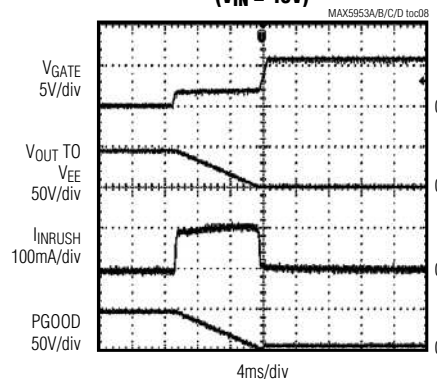

**DCUVLO THRESHOLD vs. TEMPERATURE**

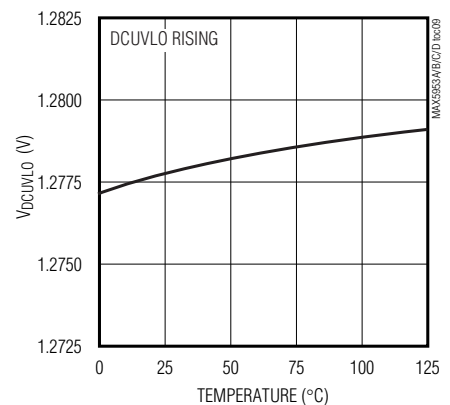

# IEEE 802.3af PD Interface and PWM Controllers with Integrated Power MOSFETs

## Typical Operating Characteristics (continued)

( $V_{IN} = (V+ - V_{EE}) = 48V$ , GATE = PGOOD = unconnected, GND connected to OUT, HVIN connected to V+, UVLO = VEE,  $C_{INBIAS} = 1\mu F$ ,  $C_{REGOUT} = 2.2\mu F$ ,  $R_{RTCT} = 25k\Omega$ ,  $C_{RTCT} = 100pF$ ,  $C_{BST} = 0.22\mu F$ ,  $T_J = 0^\circ C$  to  $+125^\circ C$ , unless otherwise noted. Typical values are at  $T_J = +25^\circ C$ . All voltages are referenced to  $V_{EE}$ , unless otherwise noted.)

**HVIN STANDBY CURRENT vs. TEMPERATURE**

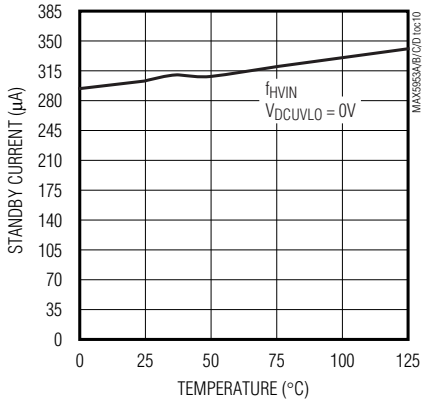

**HVIN INPUT CURRENT vs. TEMPERATURE**

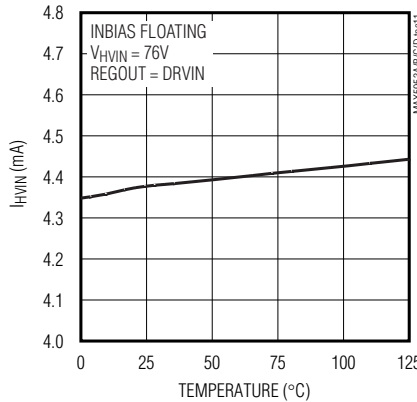

**HVIN AND INBIAS INPUT CURRENT vs. TEMPERATURE**

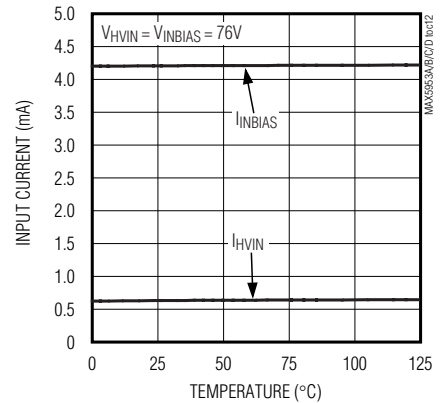

**REGOUT VOLTAGE vs. INPUT VOLTAGE**

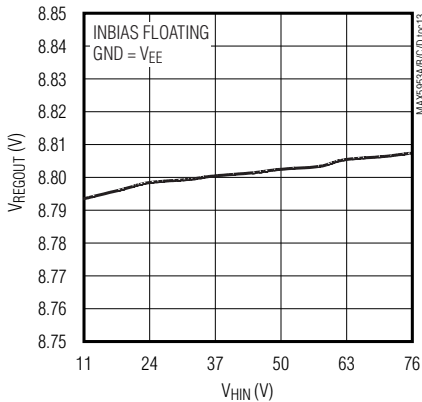

**REGOUT VOLTAGE vs. TEMPERATURE**

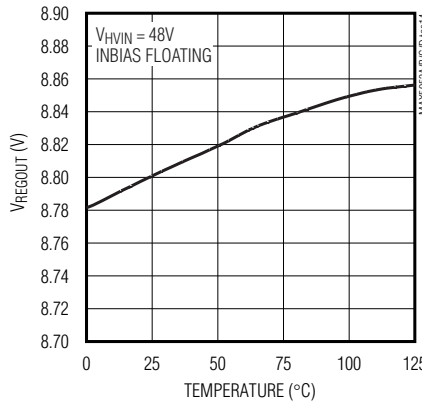

**REGOUT VOLTAGE vs. LOAD CURRENT**

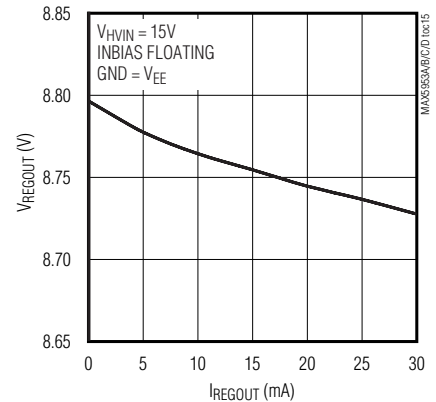

**REGOUT VOLTAGE vs. INPUT VOLTAGE**

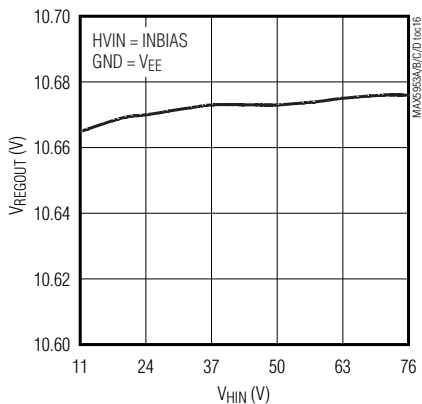

**REGOUT VOLTAGE vs. TEMPERATURE**

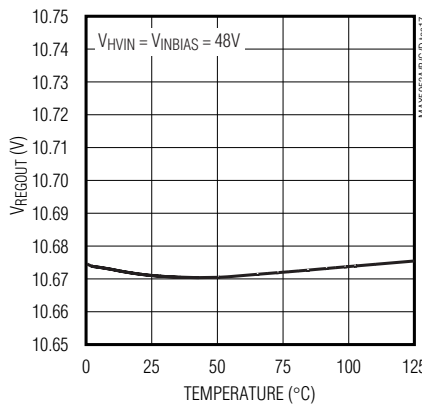

**REGOUT VOLTAGE vs. LOAD CURRENT**

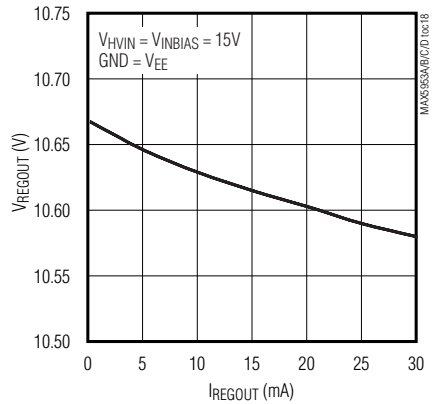



# IEEE 802.3af PD Interface and PWM Controllers with Integrated Power MOSFETs

## Typical Operating Characteristics (continued)

( $V_{IN} = (V_+ - V_{EE}) = 48V$ , GATE = PGOOD = unconnected, GND connected to OUT, HVIN connected to  $V_+$ , UVLO =  $V_{EE}$ ,  $C_{INBIAS} = 1\mu F$ ,  $C_{REGOUT} = 2.2\mu F$ ,  $R_{RTCT} = 25k\Omega$ ,  $C_{RTCT} = 100pF$ ,  $C_{BST} = 0.22\mu F$ ,  $T_J = 0^\circ C$  to  $+125^\circ C$ , unless otherwise noted. Typical values are at  $T_J = +25^\circ C$ . All voltages are referenced to  $V_{EE}$ , unless otherwise noted.)

MAX5953A/MAX5953B/MAX5953C/MAX5953D

**REGOUT UVLO VOLTAGE vs. TEMPERATURE**

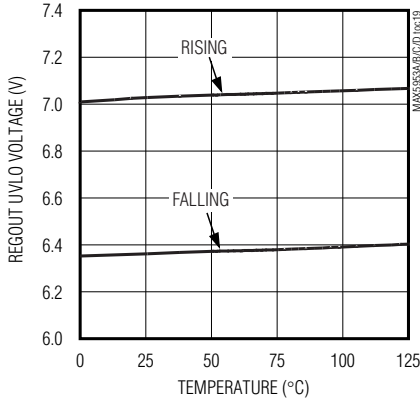

**OPERATING FREQUENCY vs. TEMPERATURE**

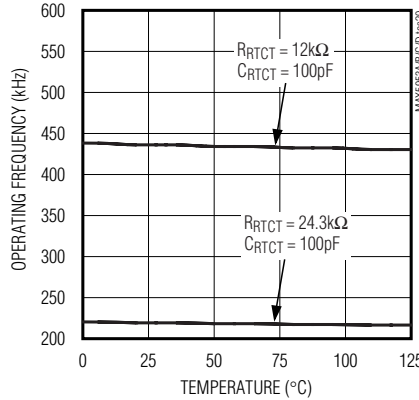

**SOFT-START CURRENT vs. TEMPERATURE**

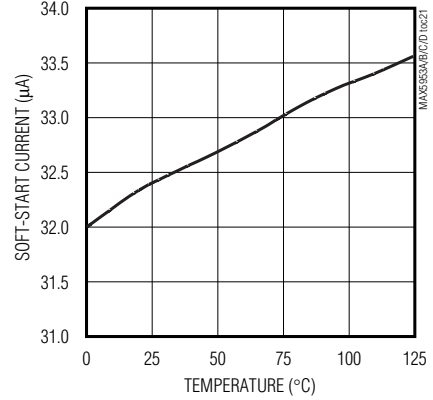

**MINIMUM RCFF AND OPTO LEVELS vs. TEMPERATURE**

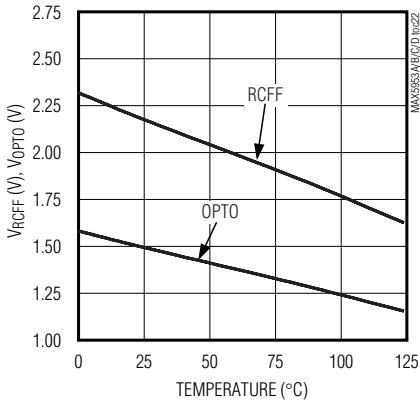

**CURRENT-LIMIT COMPARATOR THRESHOLD vs. TEMPERATURE**

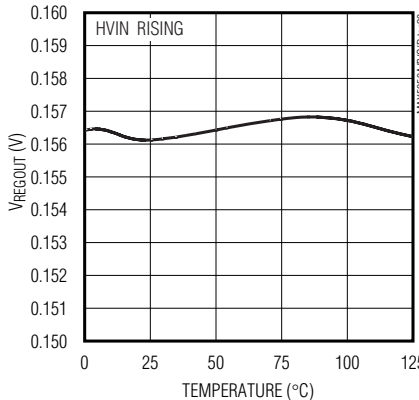

**PPWM TO XFRMRL SKEW vs. TEMPERATURE**

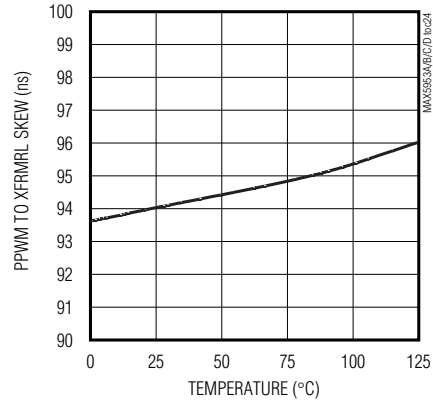

**FLTINT CURRENT vs. TEMPERATURE**

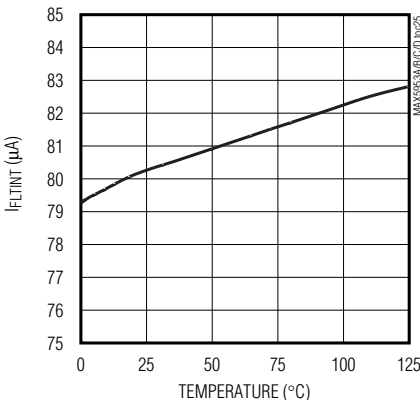

**FLTINT SHUTDOWN VOLTAGE vs. TEMPERATURE**

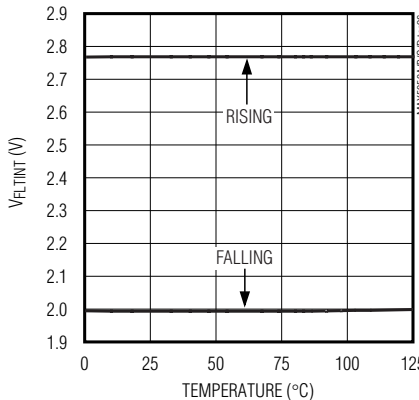

**POWER MOSFETS RDS(ON) vs. TEMPERATURE**

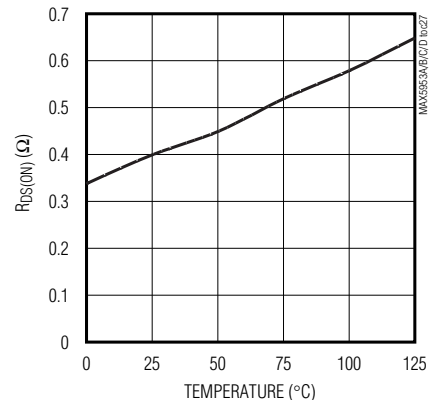

# IEEE 802.3af PD Interface and PWM Controllers with Integrated Power MOSFETs

## Pin Description

PIN	NAME	FUNCTION
1, 2, 3, 5, 7, 12, 13, 14, 17, 19, 35, 38, 46, 47, 48	N.C.	No Connection. Not internally connected. Make no electrical connection to these pins.
4	V+	Positive Input Power. Referenced to V <sub>EE</sub> .
6 (MAX5953A/MAX5953C)	UVLO	Undervoltage Lockout Programming Input for PD Interface. UVLO is referenced to V <sub>EE</sub> . When UVLO is above its threshold, the device enters the power mode. Connect UVLO to V <sub>EE</sub> to use the default undervoltage lockout threshold. Connect UVLO to the center of an external resistor-divider between V+ and V <sub>EE</sub> to define a threshold externally. The series resistance value of the external resistors must add to 25.5k $\Omega$ ( $\pm$ 1%) and replaces the detection resistor. To keep the device in undervoltage lockout, drive UVLO between V <sub>TH,G,UVLO</sub> and V <sub>REF,UVLO</sub> .
6 (MAX5953B/MAX5953D)	N.C.	No Connection. Not internally connected. Make no electrical connection to this pin.
8	RCLASS	Classification Setting for PD Interface. RCLASS is referenced to V <sub>EE</sub> . Add a resistor from RCLASS to V <sub>EE</sub> to set a PD class (see Tables 1 and 2).
9	GATE	Gate of Internal Isolation n-Channel Power MOSFET. GATE is referenced to V <sub>EE</sub> . GATE sources 10 $\mu$ A when the device enters power mode. Connect an external 100V ceramic capacitor from GATE to OUT to program the inrush current. Drive GATE to V <sub>EE</sub> to turn off the internal MOSFET. The detection and classification functions operate normally when GATE is driven to V <sub>EE</sub> .
10, 11	V <sub>EE</sub>	Negative Input Power. Source of the integrated isolation n-channel power MOSFET.
15, 16	OUT	Output Voltage. OUT is referenced to V <sub>EE</sub> . OUT is connected to the drain of the integrated isolation n-channel power MOSFET. Connect OUT to GND.
18 (MAX5953A/MAX5953B)	PGOOD	Active-High, Open-Drain Power-Good Indicator Output for PD Interface. PGOOD is referenced to OUT. PGOOD goes high impedance when V <sub>OUT</sub> is within 1.2V of V <sub>EE</sub> and when V <sub>GATE</sub> is 5V above V <sub>EE</sub> . Otherwise, PGOOD is internally pulled to OUT (given that V <sub>OUT</sub> is at least 5V below V+). PGOOD can be connected directly to CSS or DCUVLO to enable/disable the DC-DC converter.
18 (MAX5953C/MAX5953D)	$\overline{\text{PGOOD}}$	Active-Low, Open-Drain Power-Good Indicator Output for PD Interface. $\overline{\text{PGOOD}}$ is referenced to V <sub>EE</sub> . $\overline{\text{PGOOD}}$ is pulled to V <sub>EE</sub> when V <sub>OUT</sub> is within 1.2V of V <sub>EE</sub> and when V <sub>GATE</sub> is 5V above V <sub>EE</sub> . Otherwise, $\overline{\text{PGOOD}}$ goes high impedance.
20	CS	Current-Sense Input for PWM Controller. CS is referenced to PGND. The current-limit threshold is internally set to 156mV relative to PGND. The device has an internal noise filter. If necessary, connect an external RC filter from CS to PGND for additional filtering.
21	PPWM	PWM Pulse Output. Referenced to GND. PPWM leads the internal power MOSFET pulse by approximately 100ns.
22	GND	Signal Ground of PWM Controller. Connect GND to PGND.
23	PGND	Power Ground of the DC-DC Converter Power Stage. Connect PGND to GND.
24	CSS	Soft-Start Timing Capacitor Connection for PWM Controller. CSS is referenced to GND. Connect a 0.01 $\mu$ F or greater ceramic capacitor from CSS to GND. Connect to PGOOD to automatically enable the PWM controller from the PD interface.

# IEEE 802.3af PD Interface and PWM Controllers with Integrated Power MOSFETs

## Pin Description (continued)

PIN	NAME	FUNCTION
25	OPTO	PWM Comparator Inverting Input. OPTO is referenced to GND. Connect the collector of the optotransistor to OPTO and a pullup resistor to REGOUT.
26, 27	SRC	Source Connection of Low-Side Power MOSFET in the Two-Switch Power Stage of the DC-DC Converter. Connect SRC to PGND with a low-value resistor for current limiting.
28, 29	XFRMRL	Low-Side Connection for the Isolation Transformer. Drain terminal of low-side power MOSFET in the two-switch power stage of the DC-DC converter.
30	DRVIN	Supply Input for the Gate-Driver of Internal Power MOSFETs. DRVIN is referenced to PGND. Bypass DRVIN with at least 0.1 $\mu$ F to PGND. Connect DRVIN to REGOUT.
31, 32	XFRMRH	High-Side Connection for the Isolation Transformer. Source connection of high-side power MOSFET in the two-switch power stage of the DC-DC converter.
33, 34	DRNH	Drain Connection of High-Side MOSFET in the Two-Switch Power Stage of the DC-DC Converter. Connect DRNH to the most positive rail of the input supply. Bypass DRNH appropriately to handle the heavy switching current through the transformer.
36	BST	Boost Input for the DC-DC Converter. BST is the boost connection point for the high-side MOSFET driver. Connect a minimum 0.1 $\mu$ F capacitor from BST to XFRMRH with short and wide PC board traces.
37	DCUVLO	DC-DC Converter Undervoltage Lockout Input. DCUVLO is referenced to GND. Connect a resistor-divider from HVIN to DCUVLO to GND to set the UVLO threshold.
39	HVIN	DC-DC Converter Positive Input Power Supply. HVIN is referenced to GND. Connect HVIN to V+.
40	INBIAS	Input from the Rectified Bias Winding to the DC-DC Converter. INBIAS is referenced to GND. INBIAS is the input to the internal linear voltage regulator (REGOUT).
41	REGOUT	Internal Regulator Output. REGOUT is used for the DC-DC converter gate driver. REGOUT is referenced to GND. V <sub>REGOUT</sub> is always present as long as HVIN is powered with a voltage above the DCUVLO threshold. Bypass REGOUT to GND with a minimum 2.2 $\mu$ F ceramic capacitor.
42	RTCT	Oscillator Frequency Set Input for the PWM Controller. RTCT is referenced to GND. Connect a resistor from RTCT to REGOUT and a ceramic capacitor from RTCT to GND to set the oscillator frequency.
43	FLTINT	Fault Integration Input for PWM Controller. FLTINT is referenced to GND. During persistent current-limit faults, a capacitor connected to FLTINT is charged with an internal 80 $\mu$ A current source. Switching is terminated when V <sub>FLTINT</sub> reaches 2.7V. An external resistor connected in parallel discharges the capacitor. Switching resumes when V <sub>FLTINT</sub> drops to 1.9V.
44	RCFF	Feed-Forward Input for PWM Controller. RCFF is referenced to GND. To generate the PWM ramp, connect a resistor from RCFF to HVIN and a capacitor from RCFF to GND.
45	RAMP	Ramp Sense Input for PWM Controller. Connect RAMP to RCFF.
—	EP	Exposed Paddle. EP is internally unconnected and must be connected to V <sub>EE</sub> externally. To improve power dissipation, solder the exposed paddle to a copper pad on the PC board.

MAX5953A/MAX5953B/MAX5953C/MAX5953D

# IEEE 802.3af PD Interface and PWM Controllers with Integrated Power MOSFETs

## Typical Application Circuit

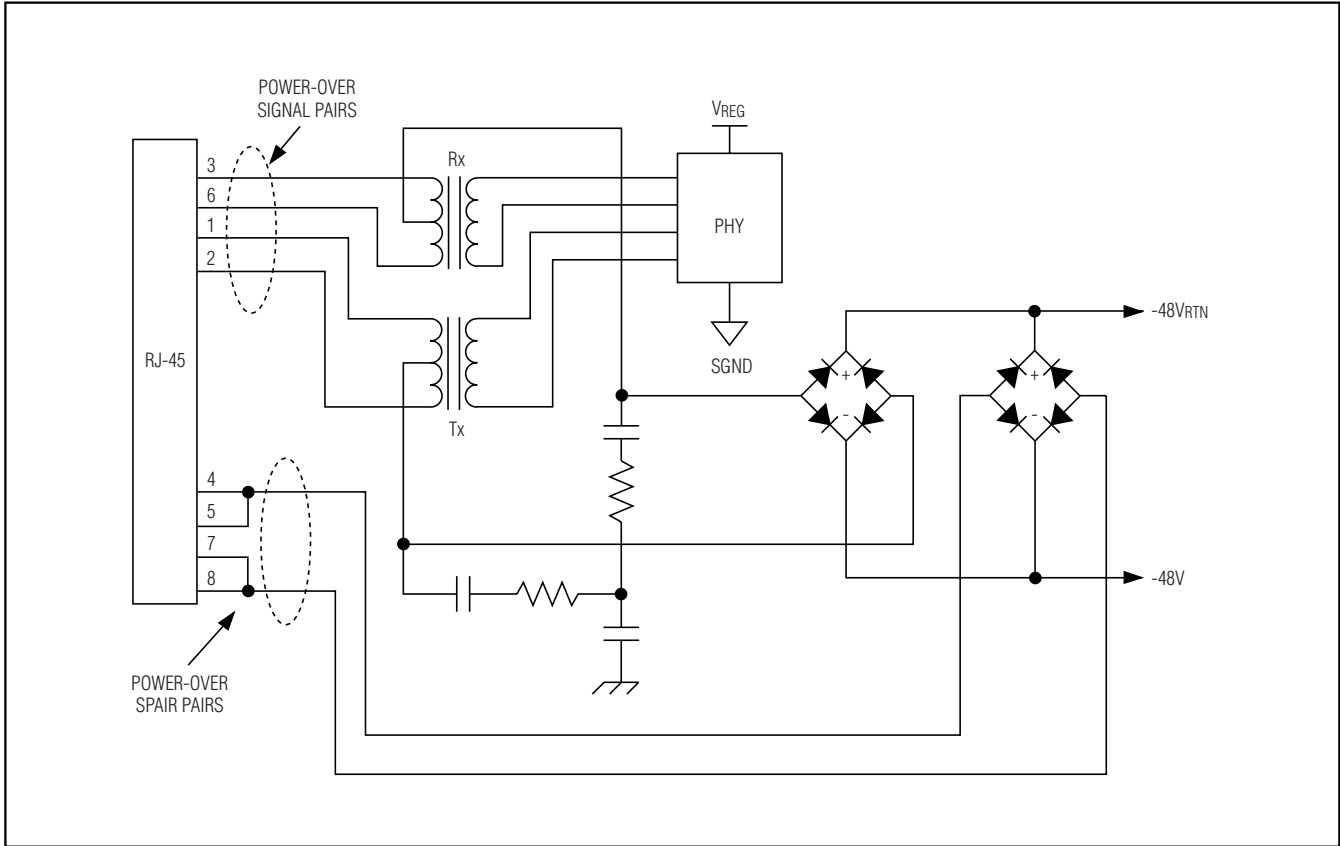
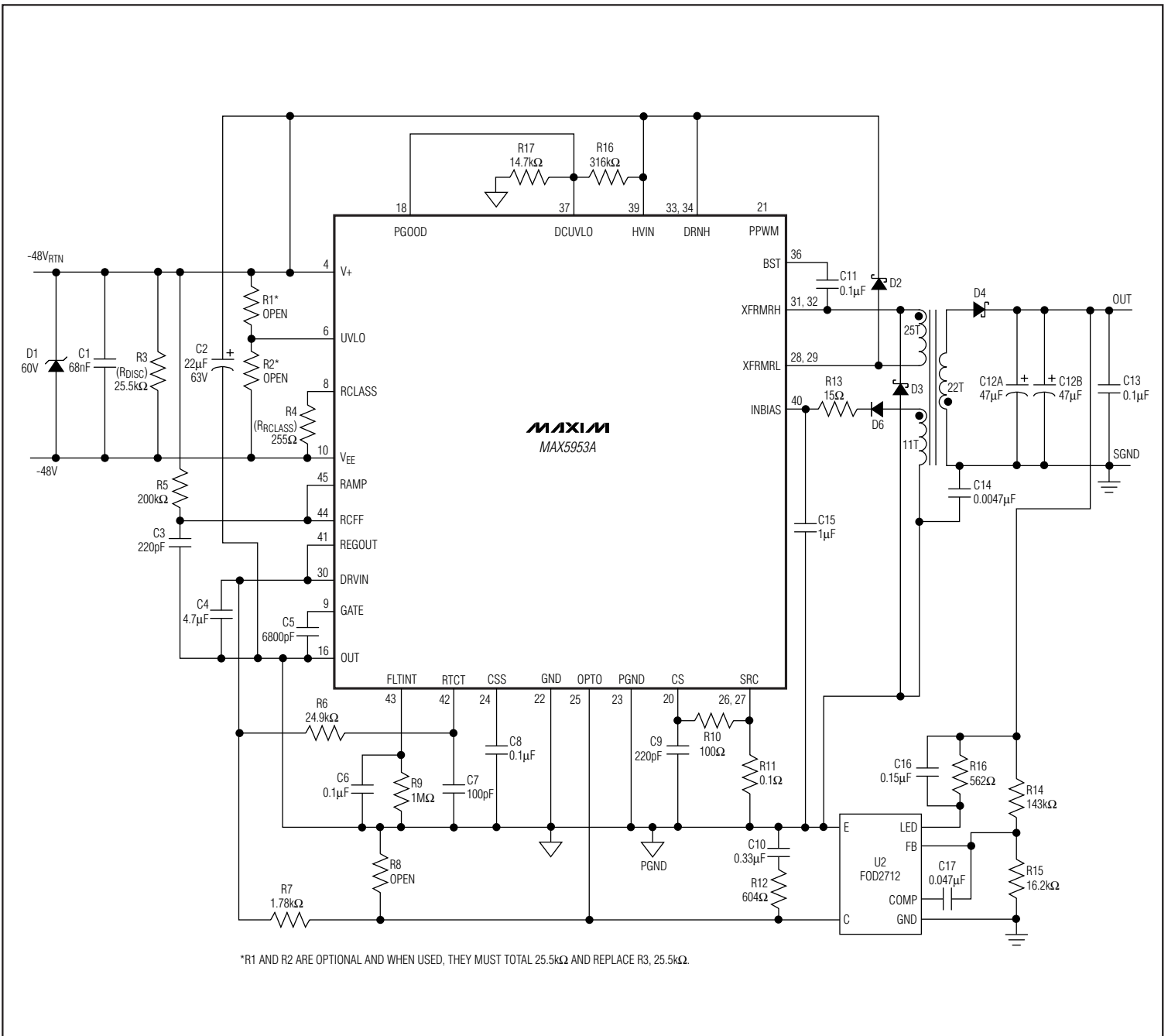

Figure 2. RJ-45 Connector, PoE Magnetic, and Input Diode Bridges

# IEEE 802.3af PD Interface and PWM Controllers with Integrated Power MOSFETs



MAX5953A/MAX5953B/MAX5953C/MAX5953D

Figure 3. Typical Application Circuit

MAXIM

# IEEE 802.3af PD Interface and PWM Controllers with Integrated Power MOSFETs

## MAX5953A/MAX5953B/MAX5953C/MAX5953D

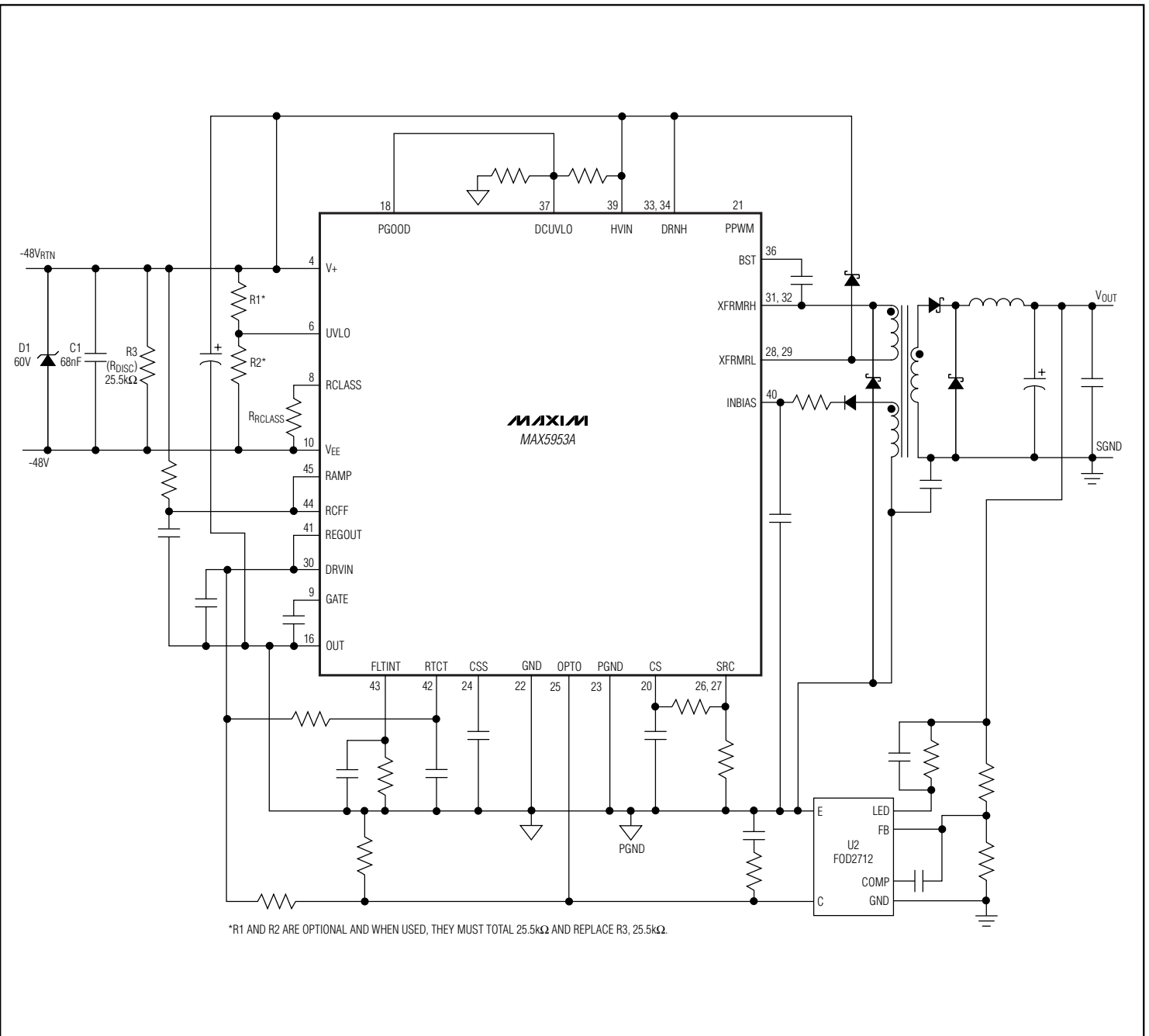

Figure 4. For higher power applications, the MAX5953A/MAX5953B/MAX5953C/MAX5953D can be used in a two-switch forward converter configuration

# IEEE 802.3af PD Interface and PWM Controllers with Integrated Power MOSFETs

## Detailed Description

### PD Interface

The MAX5953A/MAX5953B/MAX5953C/MAX5953D include complete interface function for a PD to comply with the IEEE 802.3af standard in a PoE system. They provide the PD with a detection signature, a classification signature, and an integrated isolation switch with programmable inrush current control. An integrated MOSFET provides PD isolation during detection and classification. All devices guarantee a leakage current offset of less than 10µA during the detection phase. A programmable current limit prevents high inrush current during power-on. The device features power-mode UVLO with wide hysteresis and long deglitch time to compensate for twisted-pair-cable resistive drop and to assure glitch-free transition between detection, classification, and power-on/off phases. The MAX5953A/MAX5953C have an adjustable UVLO threshold with the default value compliant to the 802.3af standard, while the MAX5953B/MAX5953D have a lower and fixed UVLO threshold compatible with some legacy pre-802.3af PSE.

**Table 1. PD Power Classification/ RRCLASS Selection**

CLASS	USAGE	RRCLASS (Ω)	MAXIMUM POWER USED BY PD (W)
0	Default	10k	0.44 to 12.95
1	Optional	732	0.44 to 3.84
2	Optional	392	3.84 to 6.49
3	Optional	255	6.49 to 12.95
4	Not Allowed	178	Reserved*

\*Class 4 reserved for future use.

**Table 2. Setting Classification Current**

CLASS	RRCLASS (Ω)	VIN* (V)	CLASS CURRENT SEEN AT VIN (mA)		IEEE 802.3af PD CLASSIFICATION CURRENT SPECIFICATION (mA)	
			MIN	MAX	MIN	MAX
0	10k	12.6 to 20	0	2.00	0	4
1	732	12.6 to 20	9.17	11.83	9	12
2	392	12.6 to 20	17.29	19.71	17	20
3	255	12.6 to 20	26.45	29.55	26	30
4	178	12.6 to 20	36.60	41.40	36	44

\*VIN is measured across the MAX5953A/MAX5953B/MAX5953C/MAX5953D input pins (V+ - VEE), which do not include the diode bridge voltage drop.

### Operating Modes

Depending on the input voltage ( $V_{IN} = V_+ - V_{EE}$ ), the PD front-end section of the MAX5953A/MAX5953B/MAX5953C/MAX5953D operate in three different modes: PD detection signature, PD classification, and PD power. All voltage thresholds are designed to operate with or without the optional diode bridge while still complying with the IEEE 802.3af standard (see Figure 2).

#### Detection Mode ( $1.4V \leq V_{IN} \leq 10.1V$ )

In detection mode, the power source equipment (PSE) applies two voltages on  $V_{IN}$  in the range of 1.4V to 10.1V (1V step minimum), and records the corresponding current measurements at those two points. The PSE then computes  $\Delta V/\Delta I$  to ensure the presence of the 25.5kΩ signature resistor. In this mode, most interface circuitry of the MAX5953A/MAX5953B/MAX5953C/MAX5953D is off and the offset current is less than 10µA.

#### Classification Mode ( $12.6V \leq V_{IN} \leq 20V$ )

In the classification mode, the PSE classifies the PD based on the power consumption required by the PD. This allows the PSE to efficiently manage power distribution. The IEEE 802.3af standard defines five different classes as shown in Table 1. An external resistor (RRCLASS) connected from RCLASS to VEE sets the classification current.

The PSE determines the class of a PD by applying a voltage at the PD input and measuring the current sourced out of the PSE. When the PSE applies a voltage between 12.6V and 20V, the IC exhibits a current characteristic with values indicated in Table 2. The PSE uses the classification current information to classify the power requirement of the PD. The classification current includes the current drawn by the 25.5kΩ detection signature resistor and the supply current of the IC so the total current drawn by the PD is within the IEEE 802.3af standard figures. The classification current is turned off whenever the device is in power mode.

# IEEE 802.3af PD Interface and PWM Controllers with Integrated Power MOSFETs

## Power Mode

During power mode, when  $V_{IN}$  rises above the undervoltage lockout threshold ( $V_{UVLO,ON}$ ), the IC gradually turns on the internal n-channel MOSFET Q1 (see Figure 8). The IC charges the gate of Q1 with a constant current source ( $10\mu\text{A}$ , typ). The drain-to-gate capacitance of Q1 limits the voltage rise rate at the drain of the MOSFET, thereby limiting the inrush current. To further reduce the inrush current, add external drain-to-gate capacitance (see the *Inrush Current Limit* section). When the drain of Q1 is within 1.2V of its source voltage and its gate-to-source voltage is above 5V, the MAX5953A/MAX5953B assert the PGOOD output (MAX5953C/MAX5953D assert the PGOOD output). The IC has a wide UVLO hysteresis and turn-off deglitch time to compensate for the high impedance of the twisted-pair cable.

## Undervoltage Lockout for PD Interface

The IC operates up to a 67V supply voltage with a default UVLO turn-on ( $V_{UVLO,ON}$ ) set at 38.6V (MAX5953A/MAX5953C) or 35.4V (MAX5953B/MAX5953D) and a UVLO turn-off ( $V_{UVLO,OFF}$ ) set at 30V. The MAX5953A/MAX5953C have an adjustable UVLO threshold using a resistor-divider connected to UVLO (see Figure 3). When the input voltage goes below the UVLO threshold for more than  $t_{OFF\_DLY}$ , the MOSFET turns off.

To adjust the UVLO threshold, connect an external resistor-divider from  $V_+$  to UVLO to  $V_{EE}$ . Use the following equations to calculate R1 and R2 for a desired UVLO threshold:

$$R2 = 25.5\text{k}\Omega \times \frac{V_{REF,UVLO}}{V_{IN,EX}}$$

$$R1 = 25.5\text{k}\Omega - R2$$

where  $V_{IN,EX}$  is the desired UVLO threshold. Since the resistor-divider replaces the  $25.5\text{k}\Omega$  PD detection resistor, ensure that the sum of R1 and R2 equals  $25.5\text{k}\Omega \pm 1\%$ . When using the external resistor-divider, MAX5953A/MAX5953C have an external reference voltage hysteresis of 20% (typ). In other words, when UVLO is programmed externally, the turn-off threshold is 80% (typ) of the new UVLO threshold.

## Inrush Current Limit

The IC charges the gate of the internal MOSFET with a constant current source ( $10\mu\text{A}$ , typ). The drain-to-gate capacitance of the MOSFET limits the voltage rise rate at the drain, thereby limiting the inrush current. Add an external capacitor from GATE to OUT to further reduce the inrush current. Use the following equation to calculate the inrush current:

$$I_{INRUSH} = I_G \times \frac{C_{OUT}}{C_{GATE}}$$

The recommended typical inrush current for a PoE application is 100mA.

## PGOOD/PGOOD Output

PGOOD is an open-drain, active-high logic output. PGOOD goes high impedance when  $V_{OUT}$  is within 1.2V of  $V_{EE}$  and when GATE is 5V above  $V_{EE}$ . Otherwise, PGOOD is pulled to  $V_{OUT}$  (given that  $V_{OUT}$  is at least 5V below  $V_+$ ). Connect PGOOD directly to CSS to enable/disable the DC-DC converter. PGOOD is an open-drain, active-low logic output. PGOOD is pulled to  $V_{EE}$  when  $V_{OUT}$  is within 1.2V of  $V_{EE}$  and when GATE is 5V above  $V_{EE}$ . Otherwise, PGOOD goes high impedance. Connect a  $100\text{k}\Omega$  pullup resistor from PGOOD to  $V_+$  if needed.

## Thermal Dissipation

Thermal shutdown limits total power dissipation in the IC. If the junction temperature exceeds  $+160^\circ\text{C}$ , thermal shutdown is enabled to turn off the MAX5953A/MAX5953B/MAX5953C/MAX5953D, allowing the IC to cool. The IC turns on after the junction temperature cools by  $20^\circ\text{C}$ .

## DC-DC Converter

The MAX5953A/MAX5953B/MAX5953C/MAX5953D isolated PWM power ICs feature integrated switching power MOSFETs connected in a voltage-clamped, two-transistor, power-circuit configuration. These devices can be used in both forward and flyback configurations with a wide 11V to 76V input voltage range. The voltage-clamped power topology enables full recovery of stored magnetizing and leakage inductive energy for enhanced efficiency and reliability. A look-ahead signal for driving secondary-side synchronous rectifiers can be used to increase efficiency. A wide array of protection features include UVLO, overtemperature shutdown, and short-circuit protection with hiccup current-limit for enhanced performance and reliability. Operation up to 500kHz allows smaller external magnetics and capacitors.

## Power Topology

The two-switch forward-converter topology offers outstanding robustness against faults and transformer saturation while affording efficient use of  $0.4\Omega$  power MOSFETs. Voltage-mode control with feed-forward compensation allows the rejection of input supply disturbances within a single cycle similar to that of current-mode controlled topologies.



# IEEE 802.3af PD Interface and PWM Controllers with Integrated Power MOSFETs

The two-switch power topology recovers energy stored in both the magnetizing and the parasitic leakage inductances of the transformer. The *Typical Application Circuit*, Figure 3, shows the schematic diagram of a -48V input flyback converter using the MAX5953A. Figure 4 shows the schematic diagram of a -48V input forward converter and a 5V, 3A output isolated power supply.

### Voltage-Mode Control and the PWM Ramp

For voltage-mode control, the feed-forward PWM ramp is generated at RCFF. From RCFF, connect a capacitor to GND and a resistor to HVIN. The ramp generated is applied to the noninverting input of the PWM comparator at RAMP and has a minimum voltage of approximately 2V. The slope of the ramp is determined by the voltage at HVIN and affects the overall loop gain. The ramp peak must remain below the 5.5V dynamic range of RCFF. Assuming the maximum duty cycle approaches 50% at a minimum input voltage (PWM UVLO turn-on threshold), use the following formula to calculate the minimum value of either the ramp capacitor or resistor:

$$R_{RCFF} \times C_{RCFF} \geq \frac{V_{IN,EX}}{2 \times f_S \times V_{R(P-P)}}$$

where  $f_S$  is the switching frequency,  $V_{R(P-P)}$  is the peak-to-peak ramp voltage (2V, typ). Select  $R_{RCFF}$  resistance value between 200k $\Omega$  and 600k $\Omega$ .

Maximize the signal-to-noise ratio by setting the ramp peak as high as possible. Calculate the low-frequency, small-signal gain of the power stage (the gain from the inverting input of the PWM comparator to the output) using the following formula:

$$G_{PS} = N_{SP} \times R_{RCFF} \times C_{RCFF} \times f_S$$

where  $N_{SP}$  is the secondary to primary power transformer turns ratio.

### Secondary-Side Synchronization

The MAX5953A/MAX5953B/MAX5953C/MAX5953D provide convenient synchronization for optional secondary-side synchronous rectifiers. Figure 5 shows the connection diagram with a high-speed optocoupler. Choose an optocoupler with a propagation delay of less than 80ns. The synchronizing pulse is generated approximately 110ns ahead of the main pulse that drives the two power MOSFETs.

### Undervoltage Lockout for DC-DC Converter

Connect PGOOD to DCUVLO to ensure the PD interface is ready prior to the DC-DC converter. The DCUVLO block monitors the input voltage at HVIN through an

external resistive divider (R16 and R17) connected to DCUVLO (see Figure 3). Use the following equation to calculate R16 and R17:

$$V_{DCUVLOIN} = V_{DCUVLO} \times \left(1 + \frac{R16}{R17}\right)$$

where  $V_{DCUVLOIN}$  is the desired input voltage lockout level and  $V_{DCUVLO}$  is the undervoltage lockout threshold (1.25V, typ). Select the R17 resistance value between 100k $\Omega$  and 500k $\Omega$ .

### Optocoupled Feedback

Isolated voltage feedback is achieved by using an optocoupler as shown in Figure 3. Connect the collector of the optotransistor to OPTO and a pullup resistor between OPTO and REGOUT.

### Internal Regulators

As soon as power is provided to HVIN, internal power supplies power the DCUVLO detection circuitry. REGOUT is used to drive the internal power MOSFETs. Bypass REGOUT to GND with a minimum 2.2 $\mu$ F ceramic capacitor. The HVIN LDO steps down  $V_{HVIN}$  to a nominal output voltage ( $V_{REGOUT}$ ) of 8.75V. A second parallel LDO powers REGOUT from INBIAS. A tertiary winding connected through a diode to INBIAS powers up REGOUT once switching commences. This powers REGOUT to 10.5V (typ) and shuts off the current flowing from HVIN to REGOUT. This results in a lower on-chip power dissipation and higher efficiency.

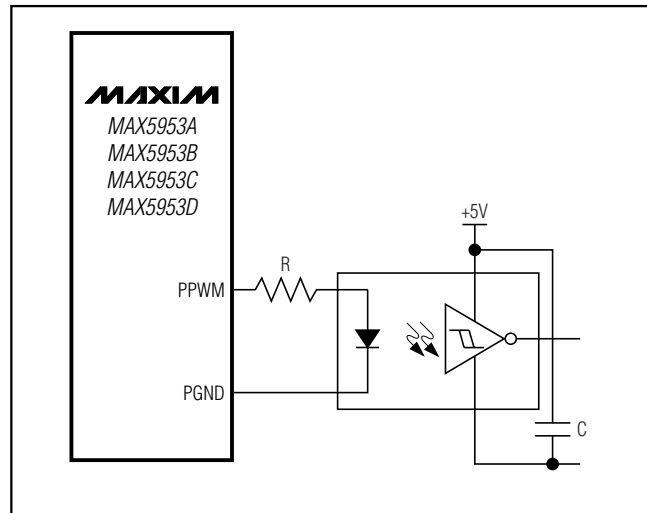

Figure 5. Secondary-Side Synchronous Rectifier Driver Using a High-Speed Optocoupler

# IEEE 802.3af PD Interface and PWM Controllers with Integrated Power MOSFETs

## Soft-Start

Program the MAX5953A/MAX5953B/MAX5953C/MAX5953D soft-start with an external capacitor ( $C_{CSS}$ ) connected between CSS and GND. When the device turns on,  $C_{CSS}$  charges with a constant current of 33 $\mu$ A, ramping up to 7.3V. During this time, the feedback input (OPTO) is clamped to  $V_{CSS} + 0.6V$ . This initially holds the duty cycle lower than the value the regulator imposes, thus preventing voltage overshoot at the output. When the IC turns off, the soft-start capacitor internally discharges to GND.

## Oscillator

The oscillator is externally programmable through a resistor connected from RTCT to REGOUT and a capacitor connected from RTCT to GND. The PWM frequency is one-half the frequency seen at RTCT with a 50% duty cycle. Use the following formula to calculate the oscillator components:

$$R_{RTCT} \cong \frac{1}{2f_s(C_{RTCT} + C_{PCB}) \ln\left(\frac{V_{REGOUT}}{V_{REGOUT} - V_{TH,RTCT}}\right)}$$

where  $C_{PCB}$  is the stray capacitance on the PC board (14pF, typ),  $V_{TH,RTCT}$  is the RTCT peak trip level, and  $f_s$  is the switching frequency.

## Integrating Fault Protection

The integrating fault protection feature allows the IC to ignore transient overcurrent conditions for a programmable amount of time, giving the power-supply time to behave like a current source to the load. This can happen, for example, under load-current transients when the control loop requests maximum current to keep the output voltage from going out of regulation. The ignore time is programmed externally by connecting a capacitor from FLTINT to GND. Under sustained overcurrent faults, the voltage across this capacitor ramps up toward the FLTINT shutdown threshold (2.7V, typ). When  $V_{FLTINT}$  reaches the shutdown threshold, the power supply shuts down. A high-value bleed resistor connected in parallel with the FLTINT capacitor allows the capacitor to discharge toward the restart threshold (1.9V, typ). FLTINT drops to the restart threshold allowing for soft-starting the supply again.

The fault integration circuit works by forcing an 80 $\mu$ A current into FLTINT for one clock cycle every time the current-limit comparator  $I_{LIM}$  (Figure 9) trips. Use the following formula to calculate the approximate capacitor needed for the desired shutdown time:

$$C_{FLTINT} \cong \frac{I_{FLTINT} \times t_{SH}}{1.4}$$

where  $I_{FLTINT}$  is typically 80 $\mu$ A, and  $t_{SH}$  is the desired ignore time during which current-limit events from the current-limit comparator are ignored.

This is an approximate formula; some testing may be required to fine tune the actual value of the capacitor.

Calculate the approximate bleed resistor needed for the desired recovery time using the following formula:

$$R_{FLTINT} \cong \frac{t_{RT}}{C_{FLTINT} \times 0.3514}$$

where  $t_{RT}$  is the desired recovery time.

Choose  $t_{RT} \geq 10 \times t_{SH}$ . Typical values for  $t_{SH}$  can range from a few hundred microseconds to a few milliseconds.

## Shutdown

Shut down the controller section of the IC by driving DCUVLO to GND using an open-collector or open-drain transistor connected to GND. The DC-DC converter section shuts down if REGOUT is below its DCUVLO level.

## Current-Sense Comparator

The current-sense (CS) comparator and its associated logic limit the peak current through the internal MOSFET. Current is sensed at CS as a voltage across a sense resistor between the source of the MOSFET and GND. The power MOSFET switches off when the voltage at CS reaches 156mV. Select the current-sense resistor,  $R_{SENSE}$ , according to the following equation:

$$R_{SENSE} = 0.156V / I_{LimPrimary}$$

where  $I_{LimPrimary}$  is the maximum peak primary-side current.

To reduce switching noise, connect CS to an external RC lowpass filter for additional filtering (Figure 3).

## Applications Information

### Design Example

#### Design Example 1: PD with three-output flyback DC-DC converter

Figure 6 shows an isolated three-output flyback DC-DC converter. It provides output voltages of 10V at 30mA, 5.1V at 1.8A, and 2.55V at 5.4A.

#### Design Example 2: PD with nonisolated step-down (buck) converter

Figure 7 shows a buck converter with 12V, 0.75A output. **Caution:** this converter does not have active current limit.

# IEEE 802.3af PD Interface and PWM Controllers with Integrated Power MOSFETs

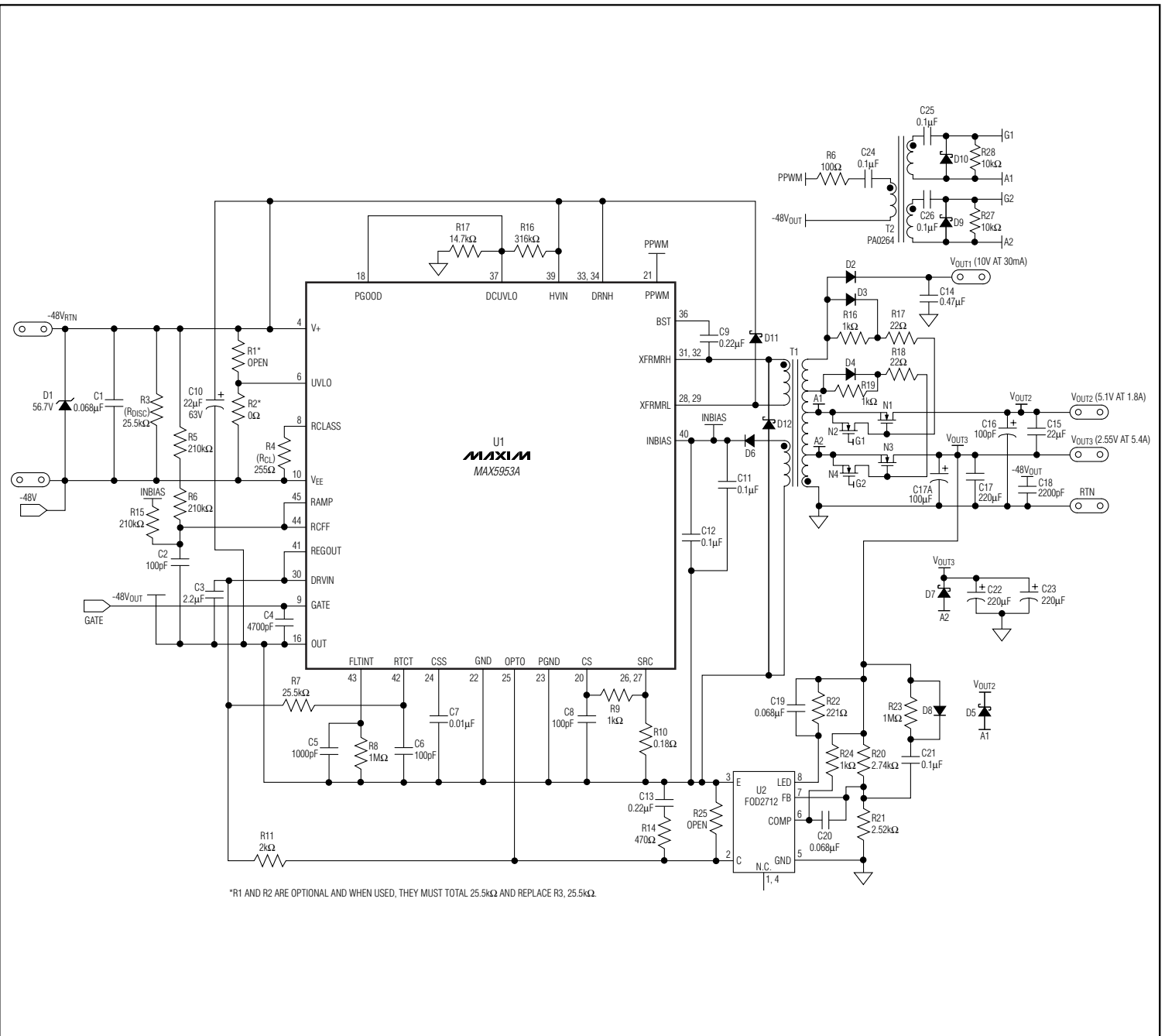

Figure 6. PD with Three-Output Flyback DC-DC Converter

MAXIM

# MAX5953A/MAX5953B/MAX5953C/MAX5953D

## IEEE 802.3af PD Interface and PWM Controllers with Integrated Power MOSFETs

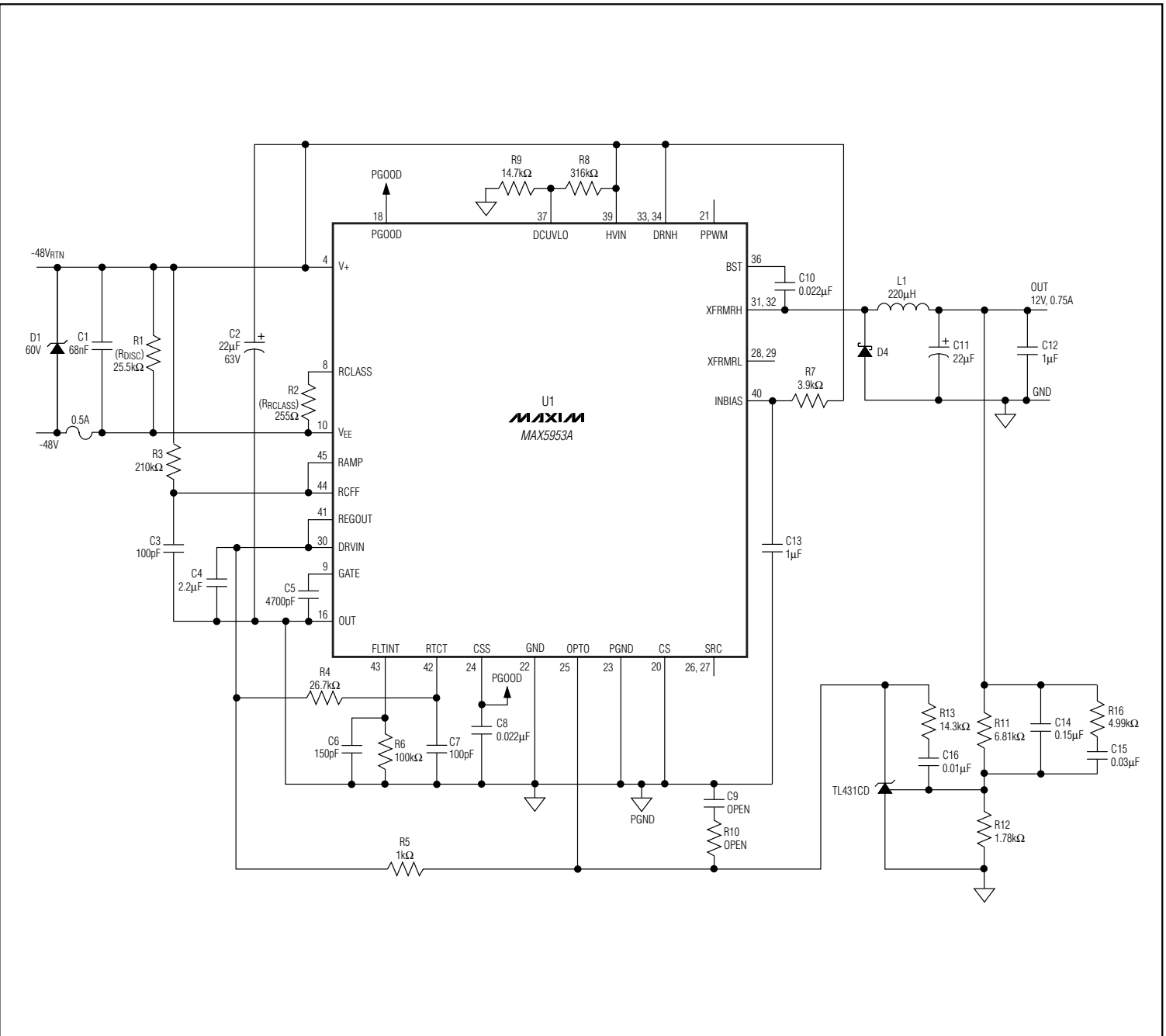

Figure 7. PD with Nonisolated Step-Down (Buck) Converter

# IEEE 802.3af PD Interface and PWM Controllers with Integrated Power MOSFETs

MAX5953A/MAX5953B/MAX5953C/MAX5953D

**Table 3. Component Suppliers**

COMPONENT	SUPPLIERS	WEBSITE
Power FETS	International Rectifier	www.irf.com
	Fairchild	www.fairchildsemi.com
	Vishay-Siliconix	www.vishay.com/brands/siliconix/main.html
Current-Sense Resistors	Dale-Vishay	www.vishay.com/brands/dale/main.html
	IRC	www.irctt.com/pages/index.cfm
Diodes	ON Semi	www.onsemi.com
	General Semiconductor	www.gensemi.com
	Central Semiconductor	www.centrasemi.com
Capacitors	Sanyo	www.sanyo.com
	Taiyo Yuden	www.t-yuden.com
	AVX	www.avxcorp.com
Magnetics	Coiltronics	www.cooperet.com
	Coilcraft	www.coilcraft.com
	Pulse Engineering	www.pulseeng.com

### **Layout Recommendations**

All connections carrying pulsed currents must be very short, as wide as possible, and have a ground plane as a return path. The inductance of these connections must be kept to a minimum due to the high di/dt of the currents in high-frequency-switching power converters.

Current loops must be analyzed in any layout proposed, and the internal area kept to a minimum to reduce radiated EMI. Ground planes must be kept as intact as possible.

# IEEE 802.3af PD Interface and PWM Controllers with Integrated Power MOSFETs

## Block Diagrams

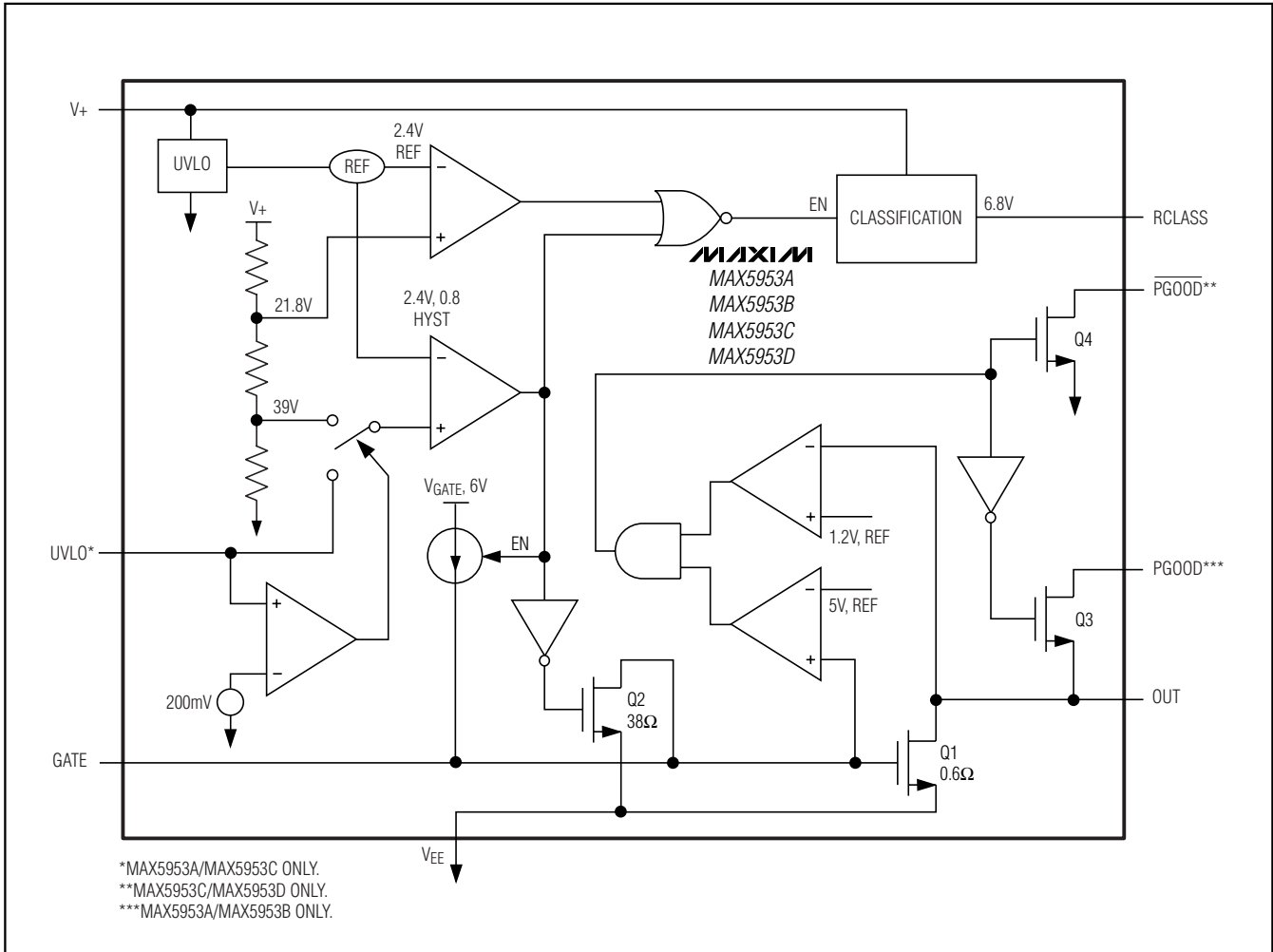

Figure 8. Powered Device Interface Block Diagram

# IEEE 802.3af PD Interface and PWM Controllers with Integrated Power MOSFETs

## Block Diagrams (continued)

MAX5953A/MAX5953B/MAX5953C/MAX5953D

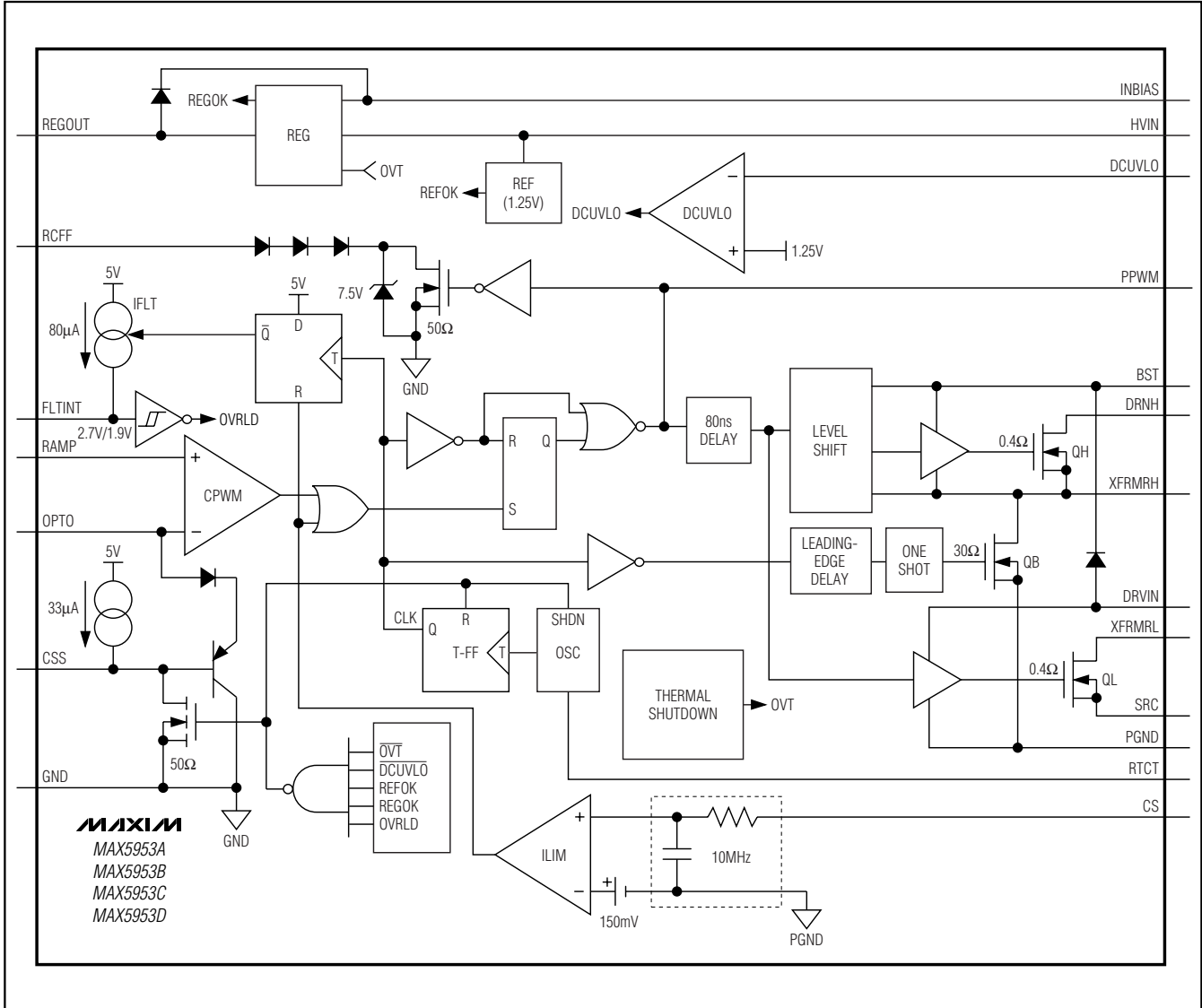
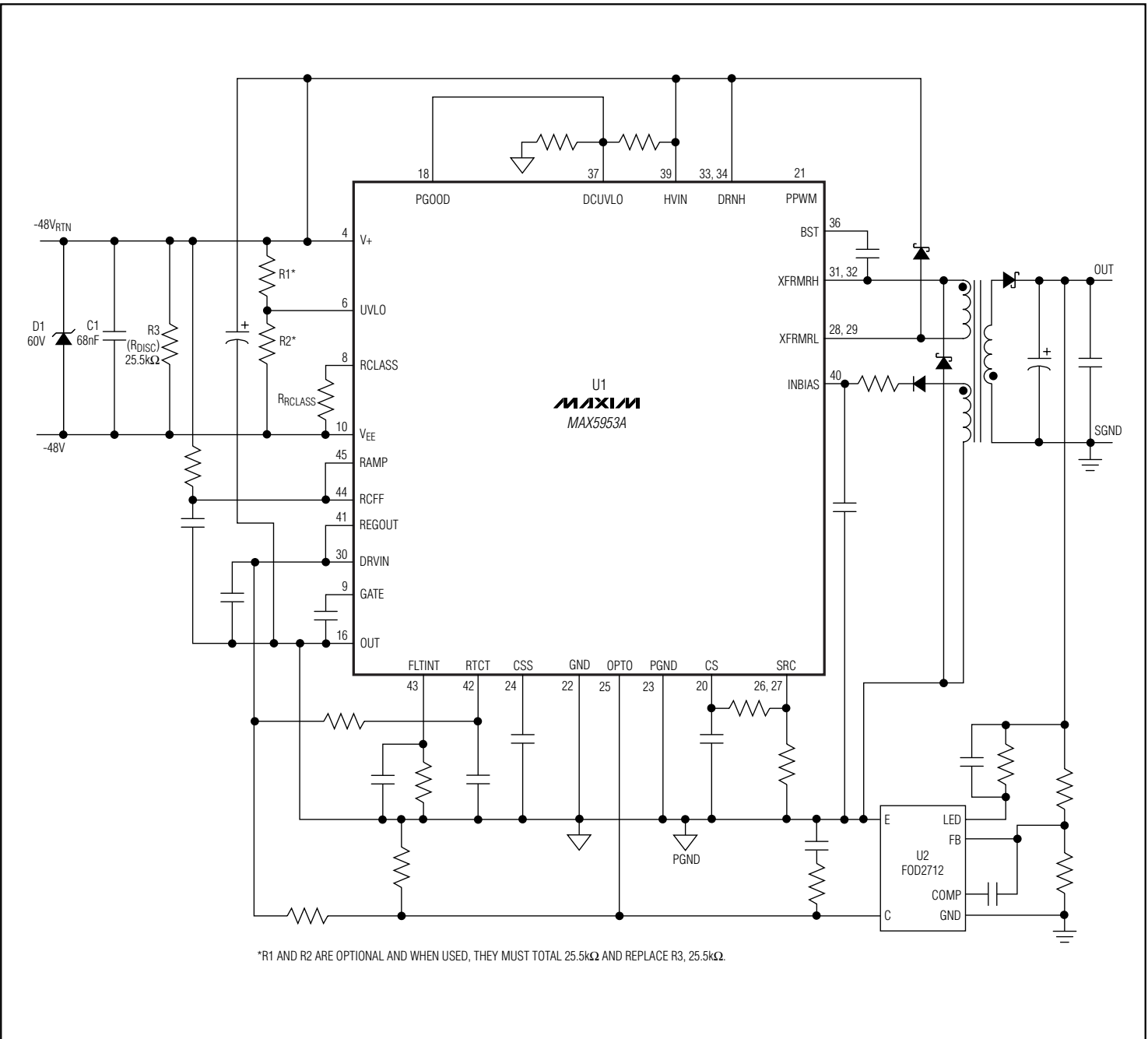

Figure 9. DC-DC Converter Block Diagram (Voltage-Mode PWM Controller and Two-Switch Power Stage)

# MAX5953A/MAX5953B/MAX5953C/MAX5953D

## IEEE 802.3af PD Interface and PWM Controllers With Integrated Power MOSFETs

Typical Operating Circuit





# IEEE 802.3af PD Interface and PWM Controllers with Integrated Power MOSFETs

## Pin Configuration

**MAX5953A/MAX5953B/MAX5953C/MAX5953D**

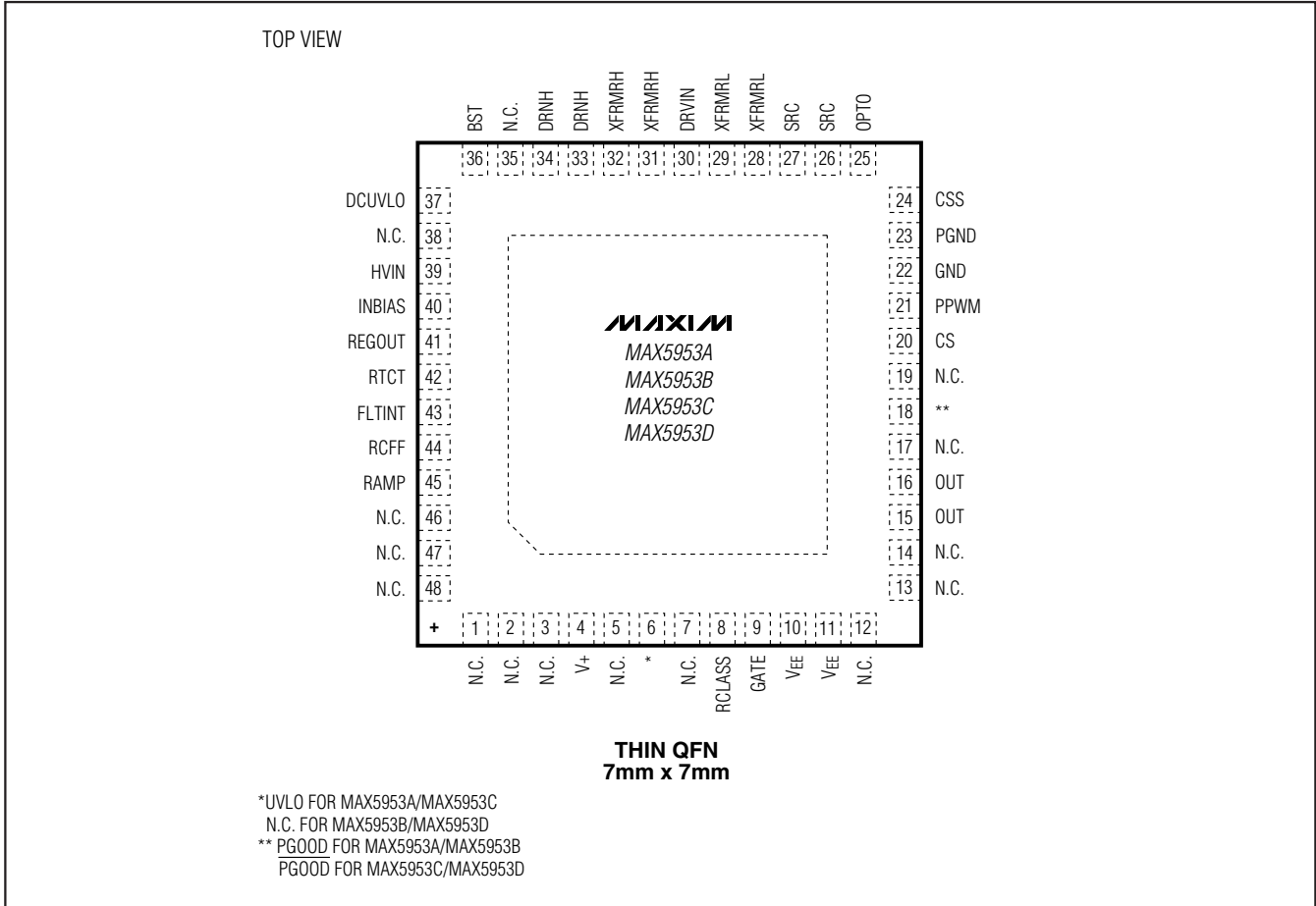

## Selector Guide

PART	PGOOD or PGOOD	UVLO
MAX5953A	PGOOD	Adjustable
MAX5953B	PGOOD	Fixed
MAX5953C	$\overline{\text{PGOOD}}$	Adjustable
MAX5953D	$\overline{\text{PGOOD}}$	Fixed

## Chip Information

PROCESS: BiCMOS

# IEEE 802.3af PD Interface and PWM Controllers with Integrated Power MOSFETs

## Package Information

(The package drawing(s) in this data sheet may not reflect the most current specifications. For the latest package outline information go to [www.maxim-ic.com/packages](http://www.maxim-ic.com/packages).)

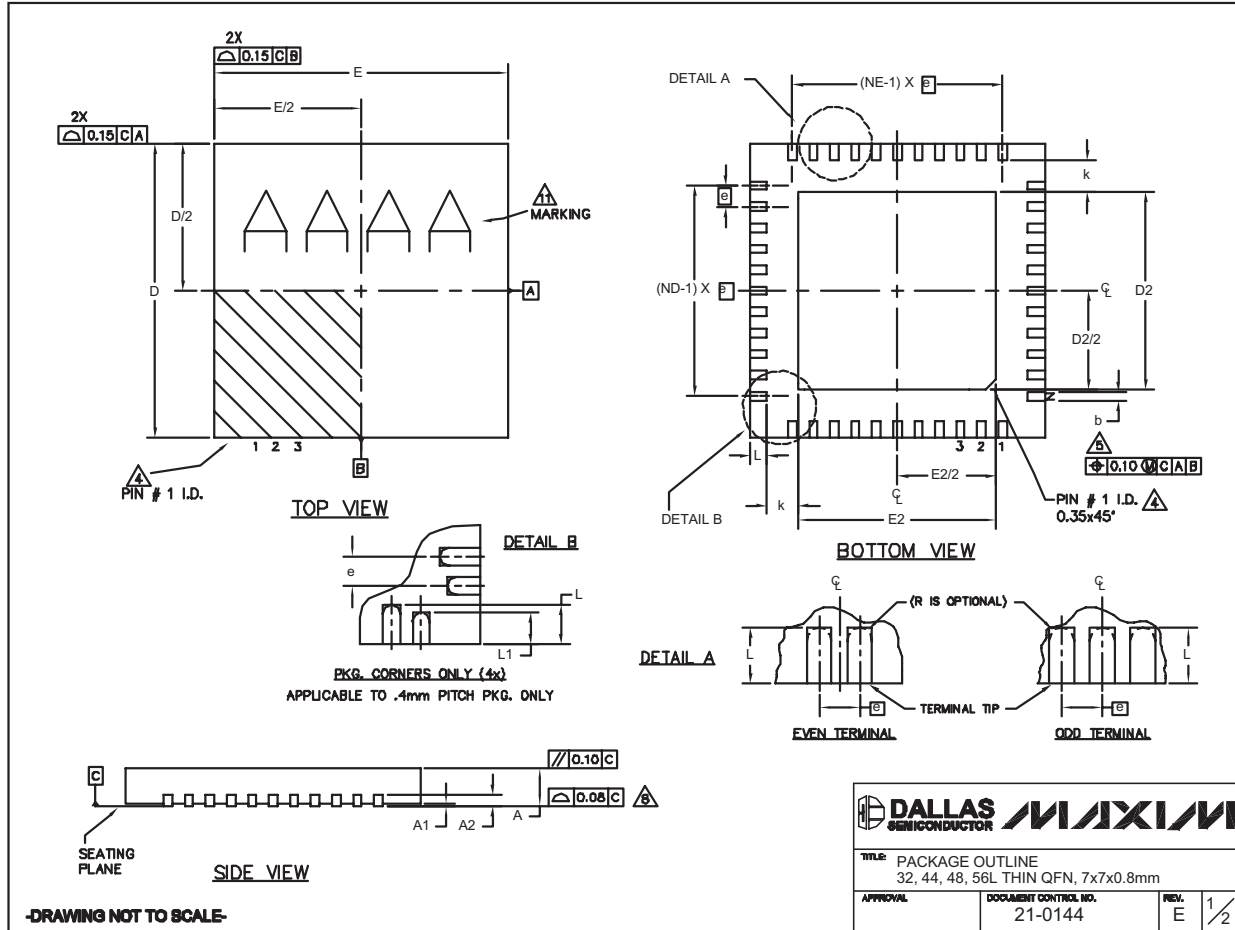

32, 44, 48L QFN.EPS

