

Two-Stage, Flickerless™ Digital Off-Line LED Driver with High PF and Low THD

1 Description

The iW3629 is a high-performance AC/DC off-line digital power supply controller for LED luminaires up to 120W or above. The two-stage design combines high power factor (PF > 0.95), low total harmonic distortion (THD <10%) and negligible line frequency ripple (< 5%) to make the iW3629 ideal for high-power non-dimmable LED lamps and luminaires.

The two-stage approach allows the first-stage boost converter to convert the rectified AC voltage ($90V_{AC}$ to $277V_{AC}$) to an intermediate voltage while correcting for power factor. The second-stage flyback converter then provides the constant current regulation to the LEDs. The combination of an active start-up circuit and fast yet smooth soft-start for both boost and flyback stages results in a start-up time (AC plug-in to 90% of set LED current) of less than a half second and fast power factor settling time.

The iW3629 operates in a quasi-resonant mode to provide high efficiency and uses Dialog's **PrimAccurate™** advanced primary-side sensing technology to achieve excellent line and load regulation without secondary-feedback components. And, by using Dialog's **Flickerless™** technology, virtually all flicker is removed from the output. The digital control algorithms used by the iW3629 maintain stability over all operating conditions without the need for any external loop compensation components, minimizing the BOM cost.

2 Features

- Supports universal, $90V_{AC}$ - $277V_{AC}$ input voltage range and output power up to 120W or above
- Two-stage design (boost and flyback)
 - » High PF (> 0.95) and low THD (< 10%) over entire input voltage range and 50%-100% load current
- Under 5% 100Hz/120Hz output current ripple
- Quasi-resonant control for both boost and flyback stages to achieve high efficiency
- Over-temperature derating protection with external NTC to program derating start temperature
- Fast yet smooth boost start-up scheme to achieve short PF settling time
- Fast line transient response ensures minimal bulk voltage overshoot within the capacitor safety limit
- Small size design
 - » Small size input bulk capacitor
 - » Small size output capacitor
 - » Small transformer
- **Flickerless** technology - removes virtually all flicker
- **PrimAccurate** primary-side sensing eliminates the need for optocoupler feedback and simplifies design
- Tight LED current regulation ($\pm 5\%$)
- Under 0.5s start-up time
- Hot-plug LED module support
- Multiple protection features:
 - » LED open circuit protection
 - » Single-fault protection
 - » Over-current protection
 - » LED short-circuit protection
 - » Current sense-resistor-short-circuit protection
 - » Input over-voltage and brown-out protection
 - » Internal junction temperature-based over-temperature protection

3 Applications

- Non-dimmable LED lamps and luminaires
- Output power up to 120W or above

Two-Stage, Flickerless™ Digital Off-Line LED Driver with High PF and Low THD

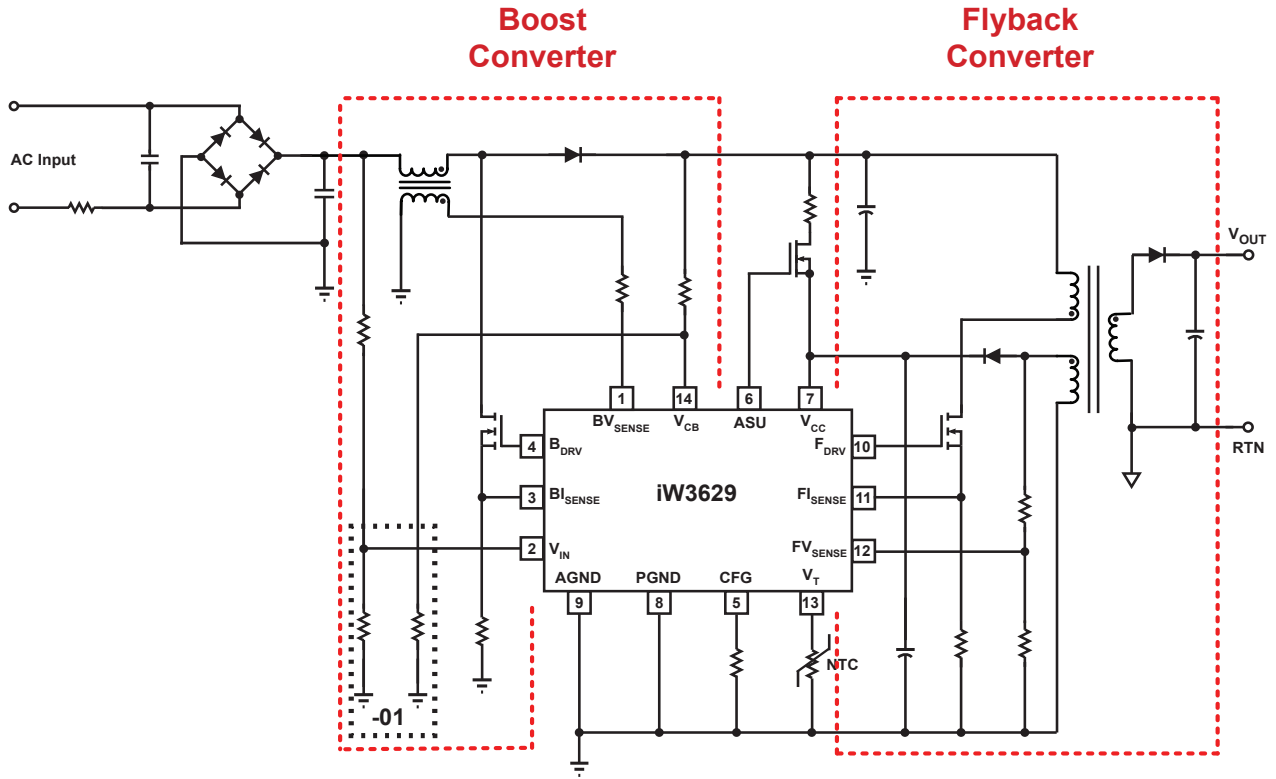

Figure 3.1 : iW3629 Typical Application Circuit with Internal (-00) or External (-01) Sensing

Two-Stage, Flickerless™ Digital Off-Line LED Driver with High PF and Low THD

4 Pinout Description

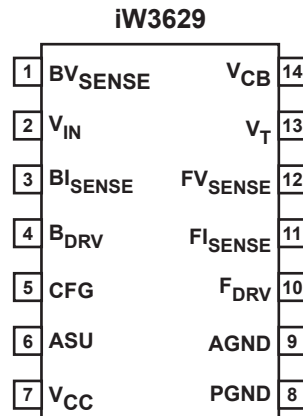

Figure 4.1 : 14-Lead SOIC-14 Package

Pin Number	Pin Name	Type	Pin Description
1	BV _{SENSE}	Analog Input	Boost inductor voltage feedback used for valley mode switching.
2	V _{IN}	Analog Input	Rectified AC line voltage feedback. -00 uses internal resistor (15kΩ typically) to sense line voltage; -01 needs an external resistor connected from this pin to GND.
3	BI _{SENSE}	Analog Input	Boost current sense (only used for cycle-by-cycle peak current limit). Connect an approximately 1kΩ resistor to the source of the boost MOSFET switch to improve noise immunity.
4	B _{DRV}	Output	Gate drive for boost MOSFET.
5	CFG	Analog In/Out	Chooses input start-up voltage and brown-out shutdown voltage.
6	ASU	Output	Control signal for active start-up device. This signal is pulled low after start-up is finished to cut off the active device. If not using active start-up device, leave this pin floating.
7	V _{CC}	Power	Power supply for control logic and voltage sense for power-on reset circuitry. A decoupling capacitor of 0.1μF or so should be connected between the V _{CC} pin and GND.
8	PGND	Ground	Power ground.
9	AGND	Ground	Signal ground.
10	F _{DRV}	Output	Gate drive for Flyback MOSFET.
11	FI _{SENSE}	Analog Input	Primary current sense (used for cycle-by-cycle peak current control and limit). Connect an approximately 1kΩ resistor to the source of the flyback MOSFET switch to improve noise immunity.
12	FV _{SENSE}	Analog Input	Auxiliary voltage sense (used for primary-side regulation and valley mode switching).
13	V _T	Analog Input	Output power limit and shutdown control. An NTC resistor connected from this pin to GND provides over-temperature derating protection.
14	V _{CB}	Analog Input	Boost output voltage feedback. -00 uses internal resistor (15kΩ typically) to sense line voltage; -01 needs an external resistor connected from this pin to GND.

Two-Stage, Flickerless™ Digital Off-Line LED Driver with High PF and Low THD

5 Absolute Maximum Ratings

Absolute maximum ratings are the parameter values or ranges which can cause permanent damage if exceeded.

Parameter	Symbol	Value	Units
DC supply voltage range (pin 7)	V_{CC}	-0.3 to 18	V
F_{DRV} output (pin 10)		-0.3 to 18	V
B_{DRV} output (pin 4)		-0.3 to 18	V
CFG input (pin 5)		-0.3 to 4.0	V
FV_{SENSE} input (pin 12, $I \leq 10\text{mA}$)		-0.7 to 4.0	V
BV_{SENSE} input (pin 1, $I \leq 3\text{mA}$)		-0.7 to 4.0	V
V_{IN} input (pin 2)		-0.3 to 18	V
V_{CB} input (pin 14)		-0.3 to 18	V
FI_{SENSE} input (pin 11)		-0.3 to 4.0	V
BI_{SENSE} input (pin 3)		-0.3 to 4.0	V
ASU output (pin 6)		-0.3 to 18	V
V_T input (pin 13)		-0.3 to 4.0	V
Maximum junction temperature	T_{JMAX}	150	°C
Operating junction temperature	T_{JOPT}	-40 to 150	°C
Storage temperature	T_{STG}	-65 to 150	°C
Thermal Resistance Junction-to-PCB Board Surface Temperature	Ψ_{JB}	45	°C/W
ESD rating per JEDEC JESD22-A114		±2,000	V

Two-Stage, Flickerless™ Digital Off-Line LED Driver with High PF and Low THD

6 Physical Dimensions

14-Lead SOIC Package

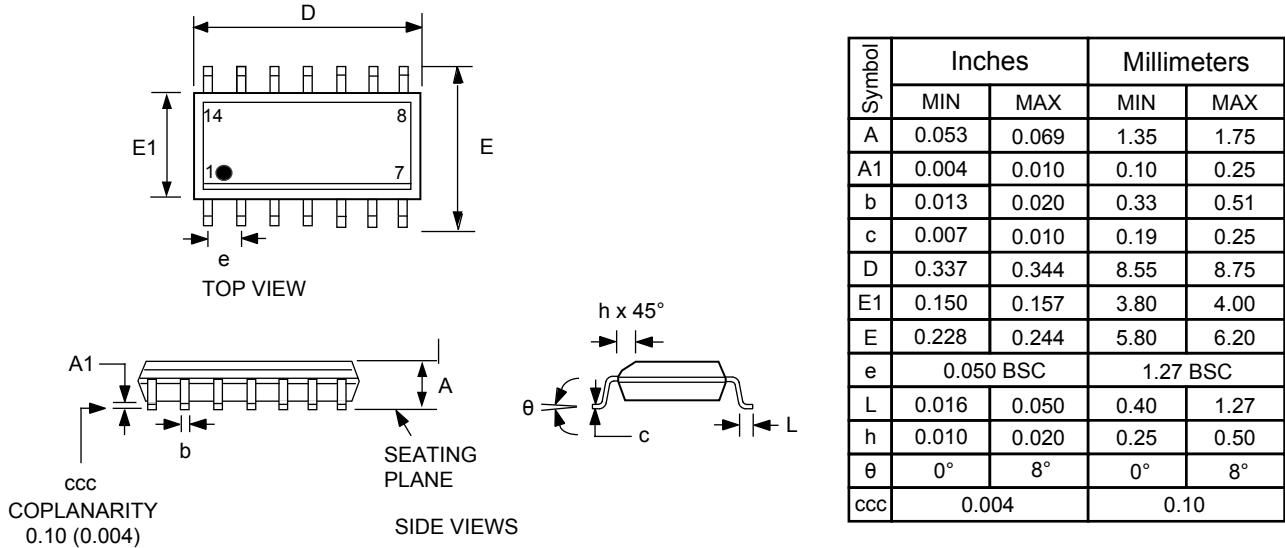

Compliant to JEDEC Standard MS12F

Controlling dimensions are in inches; millimeter dimensions are for reference only

This product is RoHS compliant and Halide free.

Soldering Temperature Resistance:

[a] Package is IPC/JEDEC Std 020D Moisture Sensitivity Level 1

[b] Package exceeds JEDEC Std No. 22-A111 for Solder Immersion Resistance; package can withstand 10 s immersion < 260°C

Dimension D does not include mold flash, protrusions or gate burrs. Mold flash, protrusions or gate burrs shall not exceed 0.15 mm per end. Dimension E does not include interlead flash or protrusion. Interlead flash or protrusion shall not exceed 0.25 mm per side.

The package top may be smaller than the package bottom. Dimensions D and E are determined at the outermost extremes of the plastic body exclusive of mold flash, tie bar burrs, gate burrs and interlead flash, but including any mismatch between the top and bottom of the plastic body.

Figure 6.1 : Physical Dimensions of 14-Pin SOIC Package

7 Ordering Information

Part Number	Options	Package	Description
iW3629-00	Internal sensing for V_{IN} and V_{CB} ; $Z_{IN} = 15k\Omega$ and $Z_{CB} = 15k\Omega$	SOIC-14	Tape & Reel ¹
iW3629-01	External sensing for V_{IN} and V_{CB}	SOIC-14	Tape & Reel ¹

Note 1: Tape & Reel packing quantity is 2,500/reel. Minimum ordering quantity is 2,500.

Two-Stage, Flickerless™ Digital Off-Line LED Driver with High PF and Low THD

Disclaimer

Information in this document is believed to be accurate and reliable. However, Dialog Semiconductor does not give any representations or warranties, expressed or implied, as to the accuracy or completeness of such information. Dialog Semiconductor furthermore takes no responsibility whatsoever for the content in this document if provided by any information source outside of Dialog Semiconductor.

Dialog Semiconductor reserves the right to change without notice the information published in this document, including without limitation the specification and the design of the related semiconductor products, software and applications.

Applications, software, and semiconductor products described in this document are for illustrative purposes only. Dialog Semiconductor makes no representation or warranty that such applications, software and semiconductor products will be suitable for the specified use without further testing or modification. Unless otherwise agreed in writing, such testing or modification is the sole responsibility of the customer and Dialog Semiconductor excludes all liability in this respect.

Customer notes that nothing in this document may be construed as a license for customer to use the Dialog Semiconductor products, software and applications referred to in this document. Such license must be separately sought by customer with Dialog Semiconductor.

All use of Dialog Semiconductor products, software and applications referred to in this document are subject to [Dialog Semiconductor's Standard Terms and Conditions of Sale](#), available on the company website (www.dialog-semiconductor.com) unless otherwise stated.

Dialog and the Dialog logo are trademarks of Dialog Semiconductor plc or its subsidiaries. All other product or service names are the property of their respective owners.

© 2017 Dialog Semiconductor. All rights reserved.

RoHS Compliance

Dialog Semiconductor's suppliers certify that its products are in compliance with the requirements of Directive 2011/65/EU of the European Parliament on the restriction of the use of certain hazardous substances in electrical and electronic equipment. RoHS certificates from our suppliers are available on request.

Contacting Dialog Semiconductor

United Kingdom (Headquarters)
Dialog Semiconductor (UK) LTD
Phone: +44 1793 757700

Germany
Dialog Semiconductor GmbH
Phone: +49 7021 805-0

The Netherlands
Dialog Semiconductor B.V.
Phone: +31 73 640 8822

Email
info_pcbg@diasemi.com

North America
Dialog Semiconductor Inc.
Phone: +1 408 845 8500

Japan
Dialog Semiconductor K. K.
Phone: +81 3 5425 4567

Taiwan
Dialog Semiconductor Taiwan
Phone: +886 281 786 222

Web site:
www.dialog-semiconductor.com

Singapore
Dialog Semiconductor Singapore
Phone: +65 64 8499 29

Hong Kong
Dialog Semiconductor Hong Kong
Phone: +852 3769 5200

Korea
Dialog Semiconductor Korea
Phone: +82 2 3469 8200

China (Shenzhen)
Dialog Semiconductor China
Phone: +86 755 2981 3669

China (Shanghai)
Dialog Semiconductor China
Phone: +86 21 5424 9058