



TAI-SAW TECHNOLOGY CO., LTD.

No. 3, Industrial 2nd Rd., Ping-Chen Industrial District,
Taoyuan, 324, Taiwan, R.O.C.

TEL: 886-3-4690038 FAX: 886-3-4697532

E-mail: tstsales@mail.taisaw.com Web: www.taisaw.com

Product Specifications Approval Sheet

Issued Date:

Product Name: SAW IF Filter 77.5 MHz (package 13.3mm x 6.5 mm)

TST Parts No.: TB0885A

Customer Parts No.: _____

Customer signature required
Company: _____
Division: _____
Approved by : _____
Date: _____

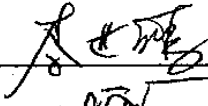
Checked by: _____ Kazuma Lee 

Approval by: _____ Francis Chen 

Date: _____ 10 / 11 / 2010

1. Customer signed back is required before TST can proceed with sample build and receive orders.
2. Orders received without customer signed back will be regarded as agreement on the specifications.
3. Any specifications changes must be approved upon by both parties and a new revision of specifications shall be released to reflect the changes.



TAI-SAW TECHNOLOGY CO., LTD.

No.3, Industrial 2nd Rd., Ping-Chen Industrial District, Taoyuan, Taiwan, R.O.C.

TEL: 886-3-4690038 FAX: 886-3-4697532

E-mail: tstsales3@mail.taisaw.com Web: www.taisaw.com

SAW Filter 77.5MHz 1MHz BW (SMD 13.3×6.5 mm)

MODEL NO.: TB0885A

REV. NO.1

A. MAXIMUM RATING:

1. Operating temperature range: -40°C to 85°C
2. Storage temperature range: -40°C to 85°C
3. Input Power Level : 10 dBm
4. Maximum DC Voltage : 10V

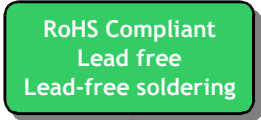

B. Characteristics :

Item	Unit	Min.	Type.	Max.
Center frequency, F_c	MHz	-	77.5	-
Insertion Loss, IL	dB	-	11.2	12.5
-1dB bandwidth	MHz	-	1.13	-
-3dB bandwidth	MHz	1.0	1.4	-
-40dB bandwidth	MHz	-	2.48	2.65
Passband Ripple F_c±0.3MHz	dB	-	0.6	1.0
Group Delay variation F_c±0.3MHz	nsec	-	350	400
Absolute Delay	unec	-	0.9	-
Temperature Coefficient	ppm/°C ²	-	-0.036	-
Source Impedance	Ohm	-	50	-
Load Impedance	Ohm	-	50	-

C. Frequency Characteristics :

(1) Wide band Response:(span 10MHz)

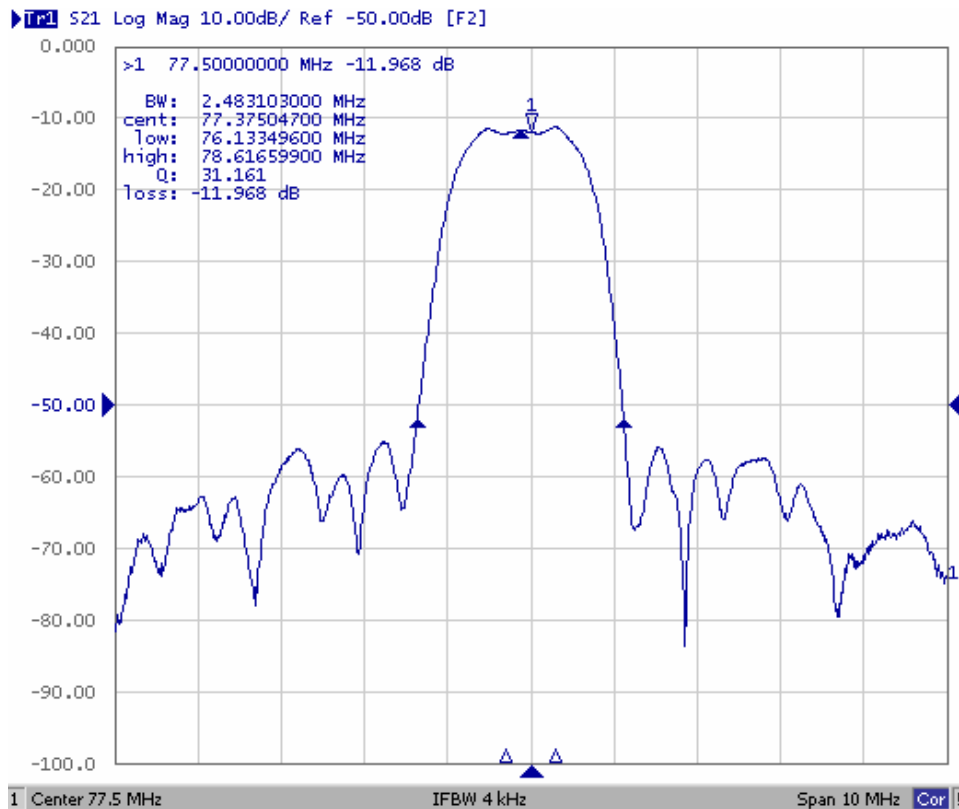

Fig1. Horizontal: 1MHz/Div Vertical: 10dB/Div

(2) Pass band Response and Group Time Delay response:

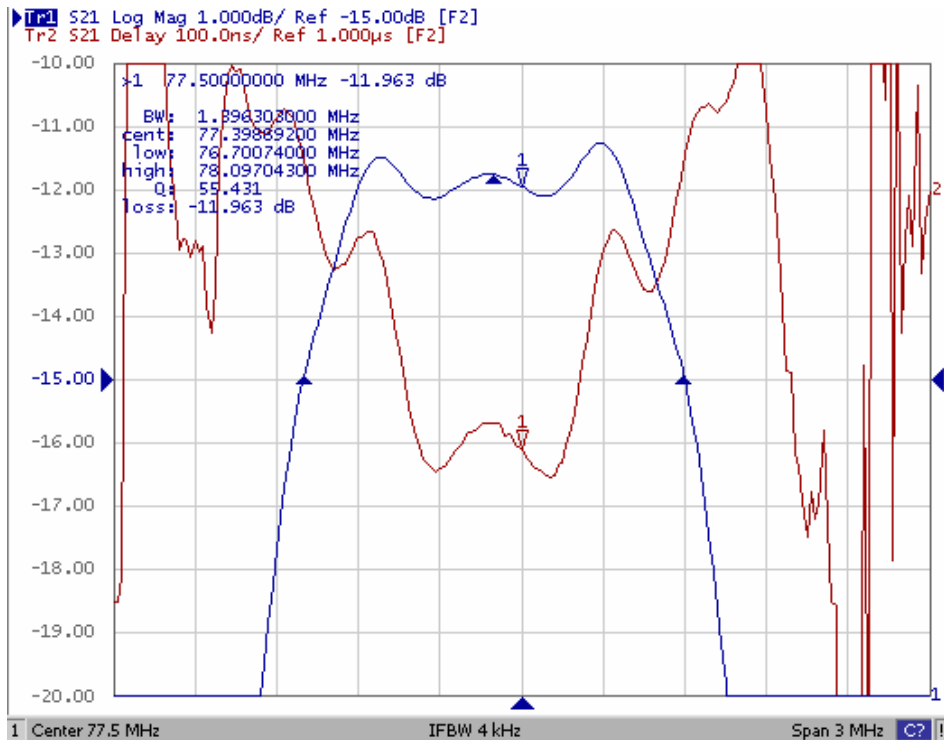

Fig2. Horizontal: 4MHz/Div Vertical: 1dB/Div
Vertical: 100ns/Div

(3) Wide band Response:

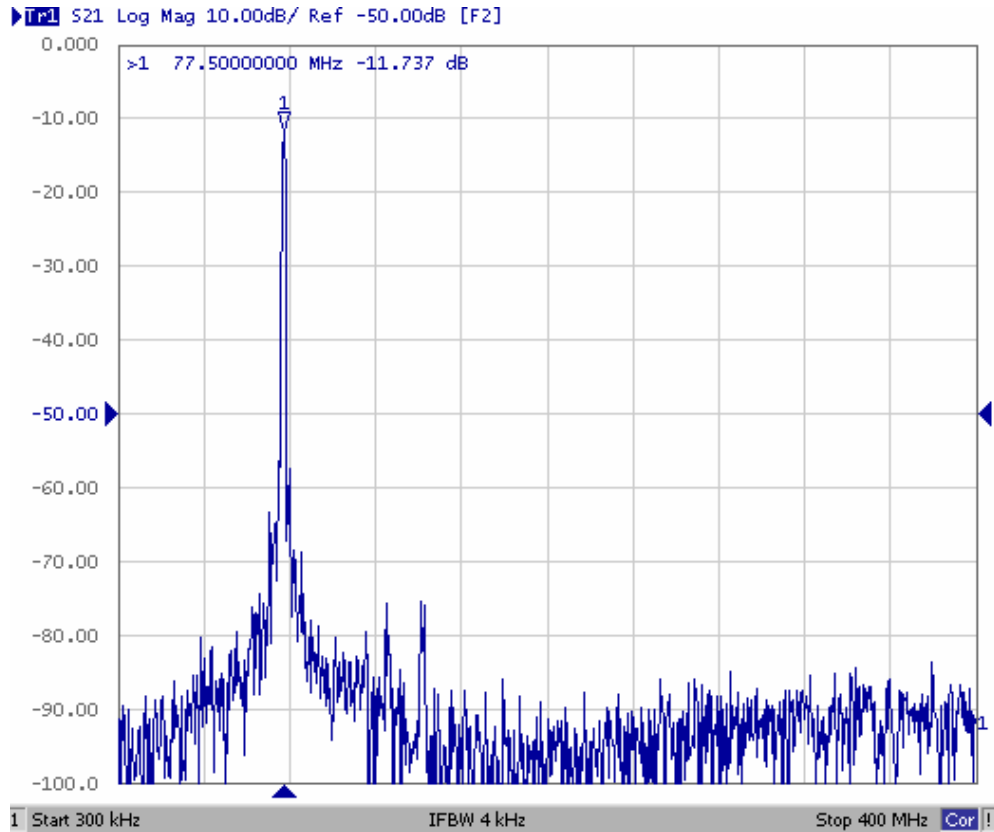
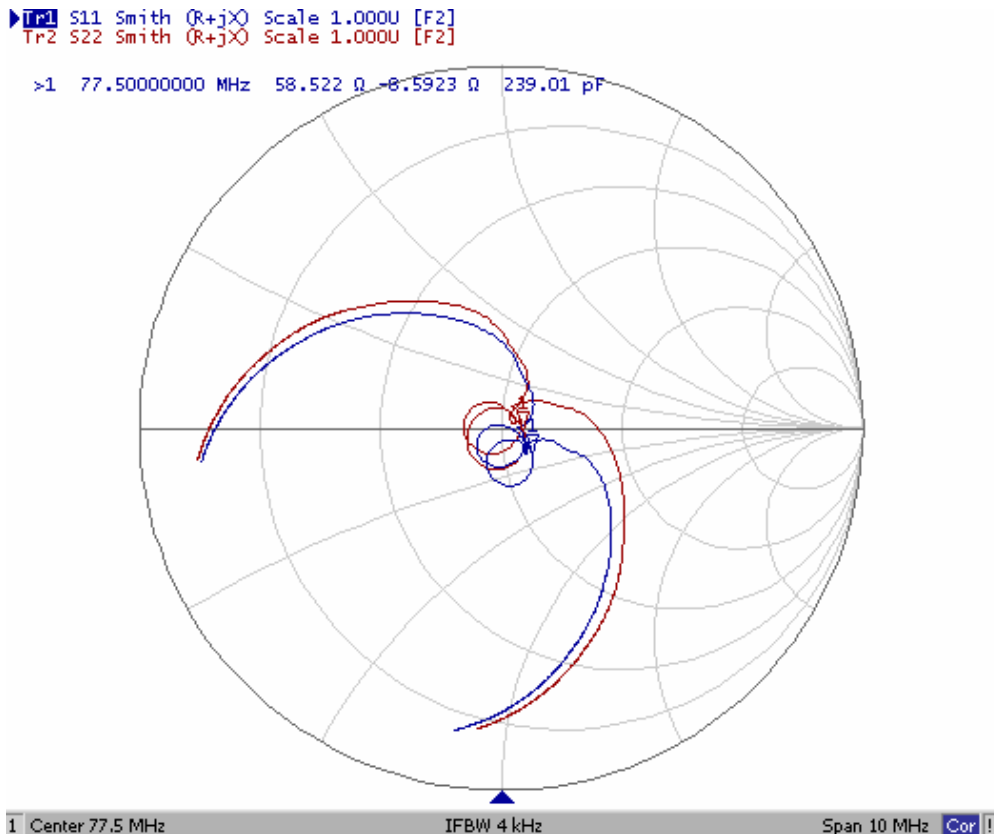
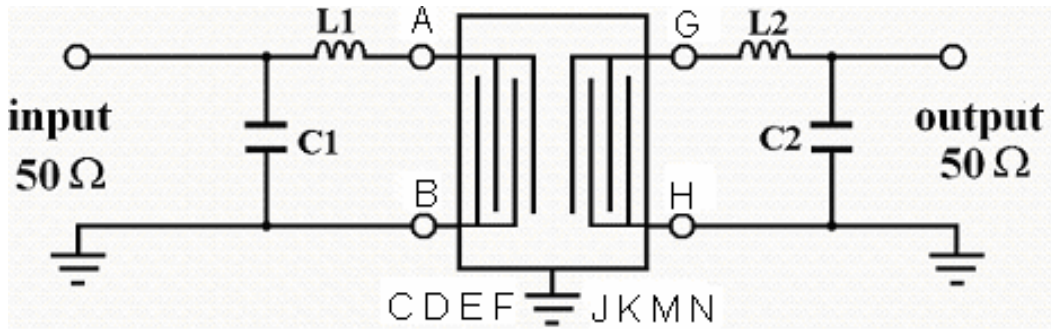

Fig3. Horizontal: 40MHz/Div Vertical: 1dB/Div

(4) Smith Chart:



D. Matching Circuit:



$L1 = 430 \text{ nH}$, $C1 = C2 = 82 \text{ pF}$, $L2 = 390 \text{ nH}$

E. Outline Drawing:

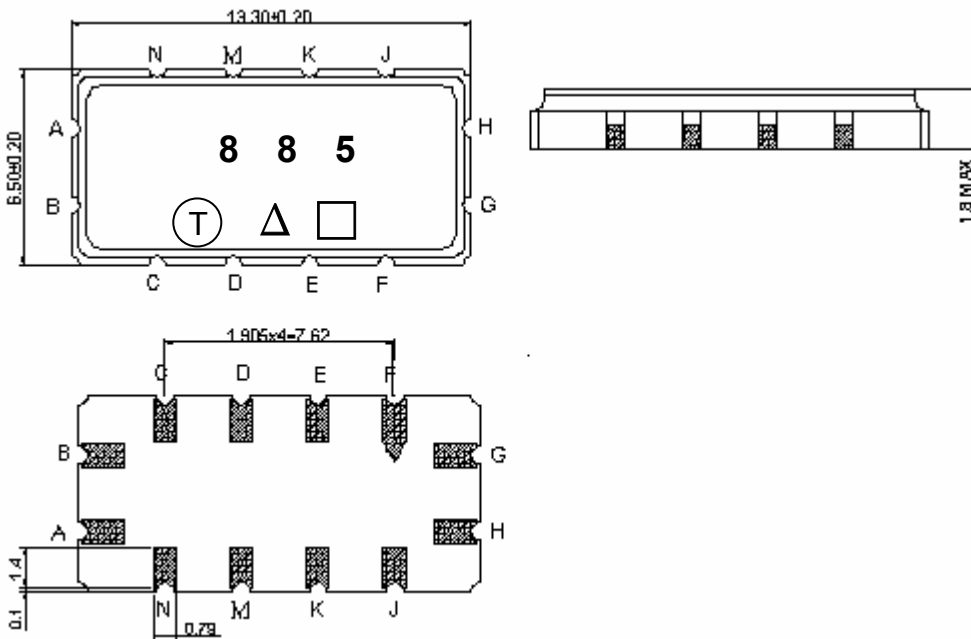

Pin A –RF input

Pin B –RF input ground

Pin G –RF output

Pin H –RF output ground

Pin C, D, E, F, J, K, M, N - Ground

□ : Week Code (Follow the table from planner each year)

Unit : mm

△ : Product / Year Code

Year	2009 2013	2010 2014	2011 2015	2012 2016
Product Code	B	b	<u>B</u>	<u>b</u>

F. PCB Footprint:

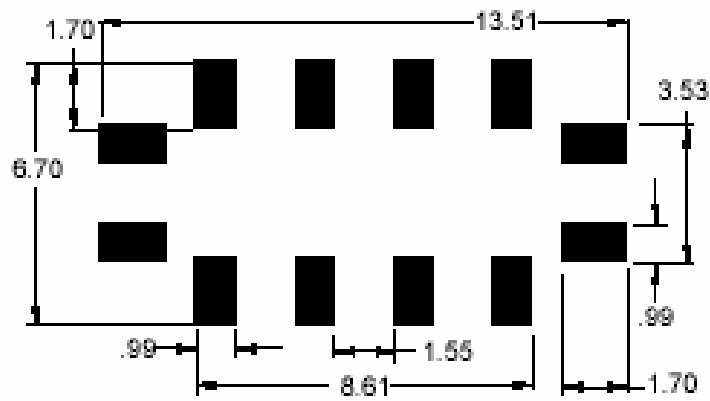

G. PACKING:

1. REEL DIMENSION

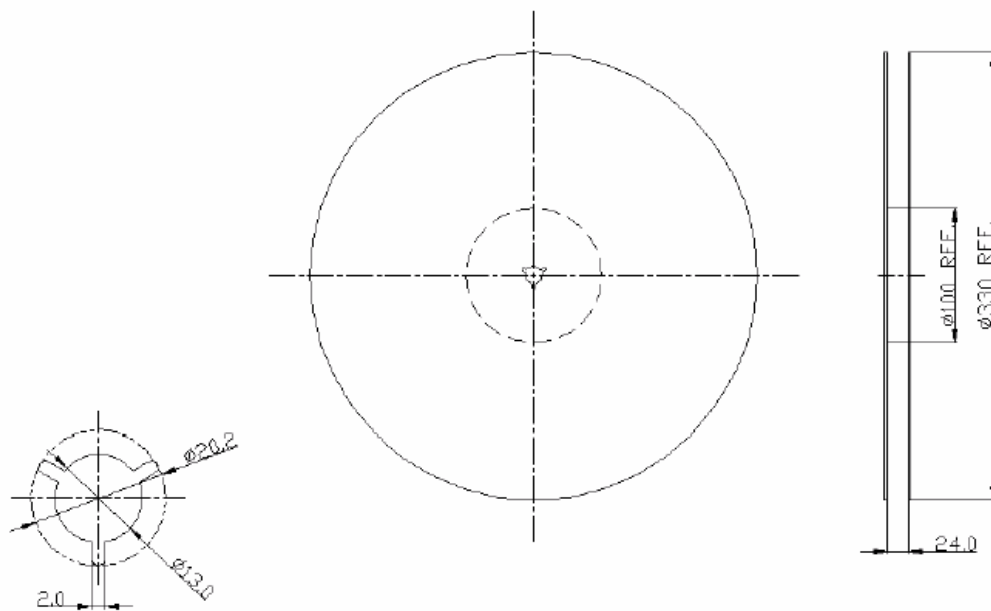

Unit: mm

2. TAPE DIMENSION

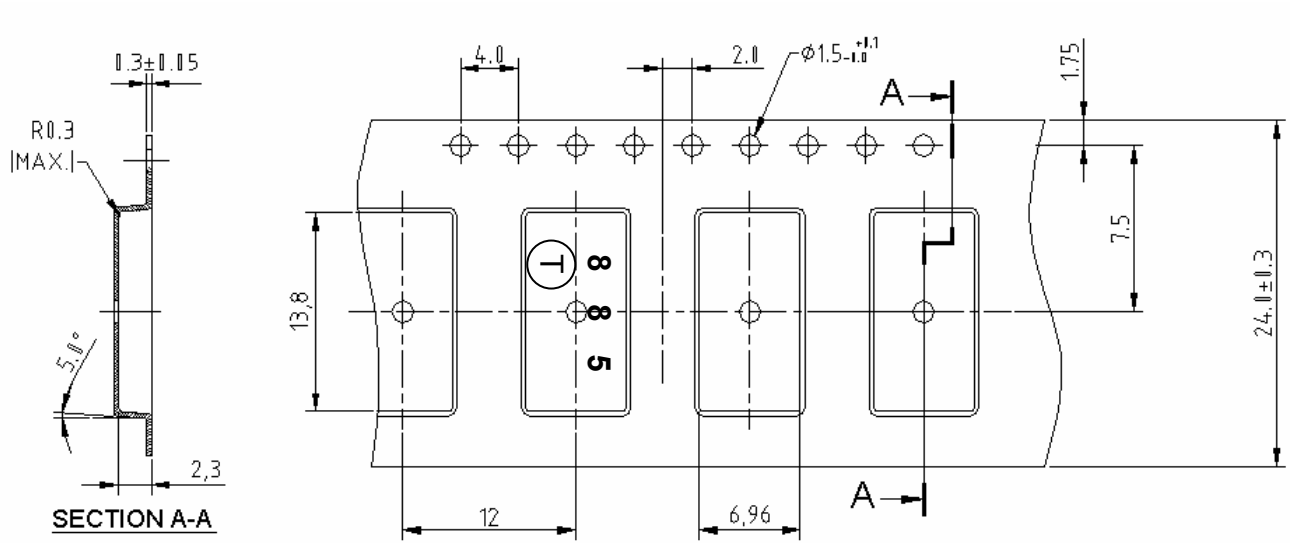

H. RECOMMENDED REFLOW PROFILE :

