

1. Mechanical Dimensions:

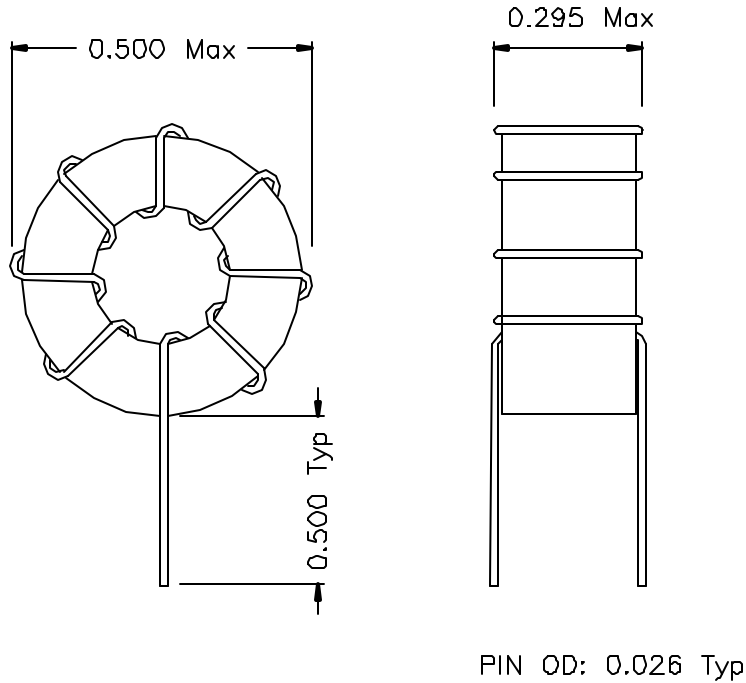

2. Schematic:

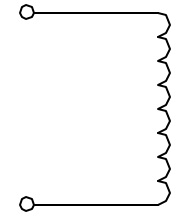

3. Electrical Specifications: @25°C

OCL: 19.60uH±12% @10KHz 1.0V
 OCL: 13.5uH Typical @1KHz 1V, 3.2ADC
 DC Resistance: 0.025 Ohms Maximum

NOTE:

STRIP AND TIN TO MOUNT PLAIN
 NEED VARNISH
 NO MARKINGS REQUIRED

DOC REV.: A/1

XFMRs Inc		Title: TOROIDAL INDUCTOR	
UNLESS OTHERWISE SPECIFIED TOLERANCES: .xxx ±0.010 Dimensions in INCH	P/N:	XF0206-V01	REV. A
	DWN.	李清儿	Jan-23-99
	CHK.	孙小松	Jan-23-99
SHEET 1 OF 1	APP.	Joe Huff	Jan-23-99