



AKD5356

Evaluation Board Rev.A for AK5356

GENERAL DESCRIPTION

AKD5356 is an evaluation board for the portable digital audio 20bit A/D converter with Pre-Amp and Analog Volume. The AKD5356 includes the analog input circuits (LINE and Pre-Amp) and also has a digital interface transmitter. Further, the AKD5356 can evaluate direct interface with AKM's D/A converter evaluation board.

■ **Ordering Guide**

AKD5356 ---Compatible with 2 types of interface
 (Cable for connecting with printer port of IBM-AT, compatible PC and control software are packed with this. This control software does not support Windows NT/2000/XP.)

FUNCTION

- **Compatible with 2 types of interface**
 - Direct interface with AKM's D/A converter evaluation boards
 - On-board AK4103 as DIT which transmits optical output
- **BNC connectors for LINE / MIC inputs**
- **BNC connectors for Pre-Amp input / output**

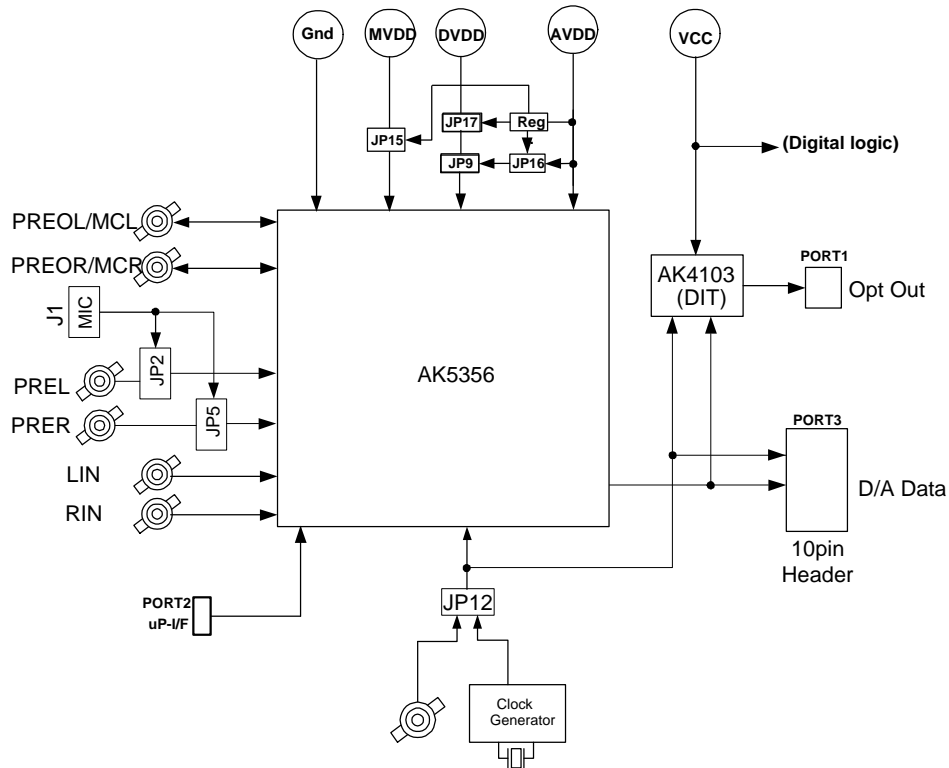

Figure 1. AKD5356 Block Diagram

* Circuit diagram and PCB layout are attached at the end of this manual.

EVALUATION BOARD MANUAL

■ Operation sequence

1) Set Up the power supply lines

[AVDD]	(Orange)	= 2.0 ~ 3.3V (typ. 2.5V, AVDD pin)
[DVDD]	(Orange)	= 1.8 ~ AVDD (typ. 2.5V, DVDD pin, U2:74LCV541, U5:74LCV07A)
[MVDD]	(Green)	= 2.4 ~ 3.3V (typ. 2.7V, MVDD pin)
[VCC]	(Red)	= 5.0V (for digital logic except the AK5356)
[AVSS]	(Black)	= 0V
[DVSS]	(Black)	= 0V
[MVSS]	(Black)	= 0V

Each supply line should be distributed from the power supply unit.

DVDD and AVDD must be the same voltage level.

When the regulator (3V output) is used, "AVDD" terminal supplies "5V".

2) Set up the evaluation mode, jumper pins and DIP switches. (See the following)

3) Power on

The AK5356 and AK4103 should be reset once bringing SW1 = SW3 = "L" upon power-up.

■ Evaluation ModeApplicable Evaluation Mode

- (1) Evaluation of A/D using DIT (Optical Link) <Default Setting>
- (2) All interface signals including master clock are fed externally.
- (3) Evaluation of A/D using DIT at MCLK = 384fs

(1) Evaluation of A/D using DIT (Optical Link) <Default Setting>

PORT1 (DIT) is used. On board DIT (AK4103) converts A/D data to an audio biphasic signal, which is output through optical connector (TOTX176). It is possible to connect AKM's D/A converter evaluation boards or the digital-amplifier that equips DIR input etc. Nothing should be connected to PORT3. When using an external clock through a BNC connector, select "EXT" on JP11 (CLK) and short JP14 (XTE).

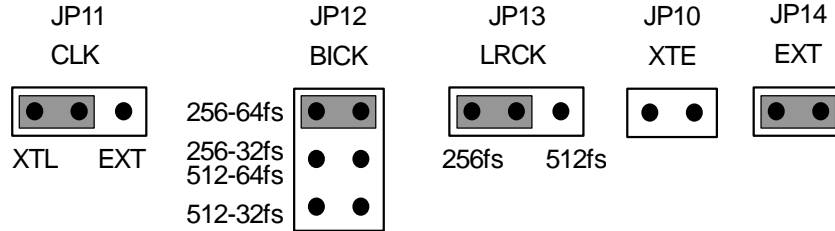

Figure 2. Jumper Setting

Audio I/F format should be the same DIP switch setting (AK4103; DIT audio format) as the register control software (AK5356 audio I/F format). Audio I/F format is shown in Table 1.

AK5356 DIF bit	SDTO	JP12	SW2			
		BICK	4103-DIF1	4103-DIF0	CKS1	CKS0
0	16bit MSB justified	256-32fs or 512-32fs	OFF	OFF	0 or 1	1
	20bit MSB justified	256-64fs or 512-64fs	OFF	OFF	0 or 1	1
1	16bit I ² S	256-32fs or 512-32fs	OFF	ON	0 or 1	1
	20bit I ² S	256-64fs or 512-64fs	OFF	ON	0 or 1	1

Table 1. AK5356 Audio I/F Format

(2) All interface signals including master clock are fed externally.

All interface signals are provided to the AK5356 through PORT3. AKM's D/A converter evaluation boards can be also connected to PORT3.

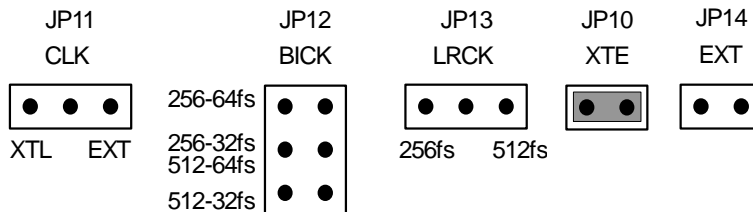

Figure 3. Jumper Setting

(3) Evaluation of A/D using DIT at MCLK=384fs.

PORT1 (DIT) is used. On board DIT (AK4103) is set to the master mode. The AK4103 provides BICK and LRCK to the AK5356 from an external master clock (MCLK). When using an external clock through a BNC connector (J8), select "EXT" on JP11 (CLK) and short JP10 (XTE). (Refer to Table 2, Table 3 and Table 4 for the set up of the DIP switches. The master mode should be selected in Table 2. The master clock (384fs) should be selected in Table 4.)

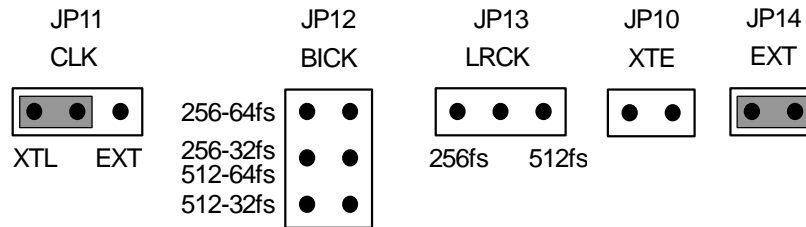

Figure 4. Jumper Setting

■ DIP Switch

[SW2]:AK4103 Mode Setting (For more detailed configurations, please refer to the AK4103 datasheet.)

No.	Pin	Default	Mode
1	4103_DIF1	L	See Table 3
2	4103_DIF0	L	
3	CKS1	L	See Table 4
4	CKS0	H	

Table 2. AK4103 Mode Setting

4103_DIF1	4103_DIF0	Mode	Clock Mode
OFF	OFF	24bit, Left justified	Slave Mode
OFF	ON	24bit, I ² S	
ON	OFF	24bit, Left justified	Master Mode
ON	ON	24bit, I ² S	

Table 3. AK4103 DIT Format Setting

CKS1	CKS0	MCLK
0	0	Don't use
0	1	256fs
1	0	384fs
1	1	512fs

Table 4. AK4103 System Clock Setting

■ Serial Control

The AK5356 can be controlled via the printer port (parallel port) of IBM-AT compatible PC. Connect PORT2 (CTRL) with PC by 10 wire flat cable packed with the AKD5356.

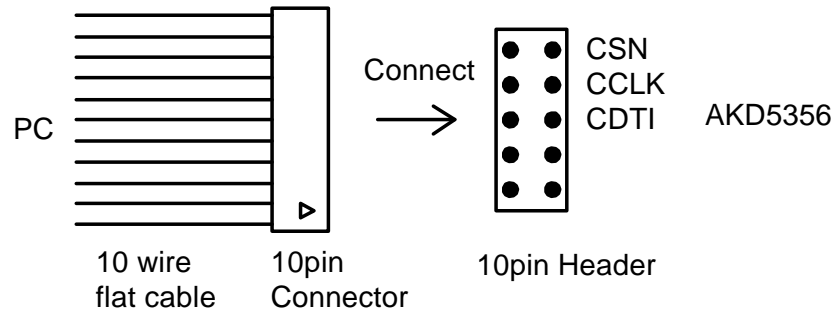

Figure 5. Connect of 10 wire flat cable

■ Other Jumper Pins

- (1) JP9 (VD) : Select DVDD pin of the AK5356
 VA: DVDD pin is supplied from AVDD pin via 10Ω.
 VD: DVDD pin is supplied from JP17.
- (2) JP15 (MVDD) : Select MVDD pin of the AK5356
 TERM: MVDD pin is supplied from MVDD terminal.
 REG : 3V is supplied to MVDD pin via the regulator.
- (3) JP16 (AVDD): Select AVDD pin of the AK5356
 TERM: AVDD pin is supplied from AVDD terminal.
 REG : 3V is supplied to AVDD pin via the regulator.
- (4) JP17 (DVDD): Select digital logics [DVDD pin, U2(74LCV541), U5(74LCV07A)]
 TERM: The digital logics are supplied from DVDD terminal.
 REG : 3V is supplied to the digital logics via regulator.

■ The function of the toggle SW

Upper-side is "H" and lower-side is "L".

[SW1] (PDN): Reset the AK5356. Keep "H" during normal operation.

[SW3] (DIT): Reset the AK4103. Keep "H" during normal operation.

■ Input / Output Circuit and Jumper Setting

1. LIN/RIN Input circuit

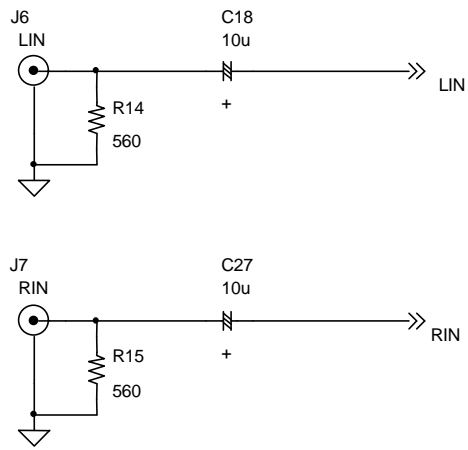

Figure 6. LIN/RIN Input Circuit

2. MICL/MICR Input and Pre-Amp Output Circuit

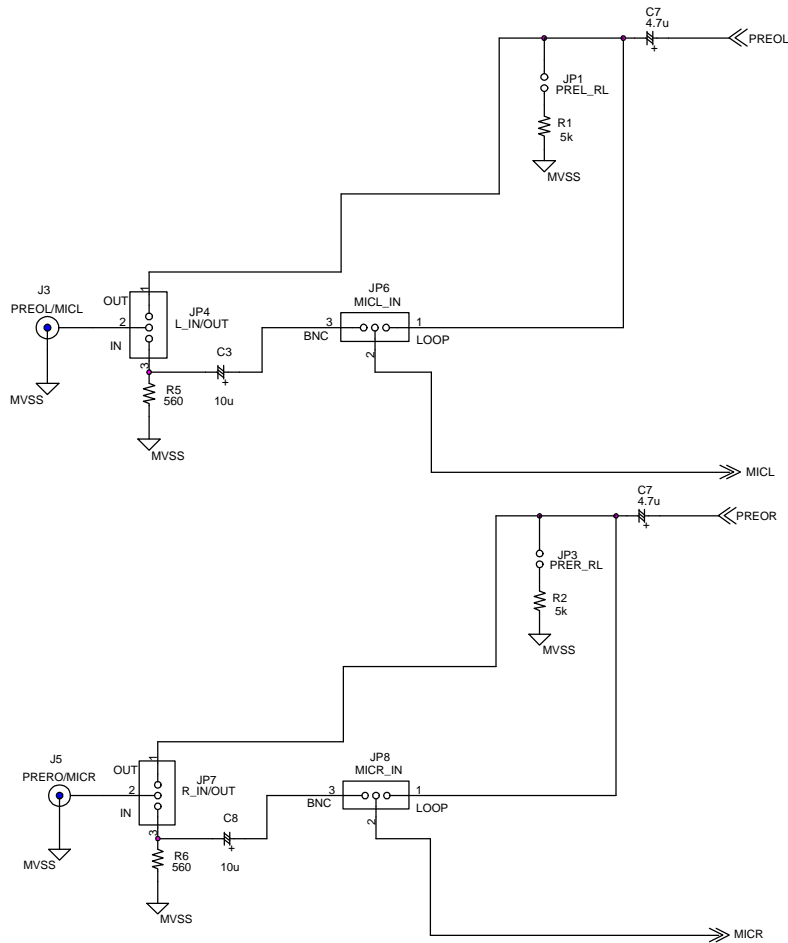

Figure 7. MICL/MICR Input and Pre-Amp Output Circuit

(1) Analog signals are output from PREOL/PREOR pins via J3/J5 connectors.

- JP1(PREL_RL) : Short
- JP3(PRER_RL) : Short
- JP4(L_IN/OUT): OUT
- JP7(R_IN/OUT): OUT
- JP6(MICL_IN) : BNC
- JP8(MICR_IN) : BNC

(2) MICL/MICR pins are input from BNC connectors (J3/J5).

- JP4(L_IN/OUT): IN
- JP7(R_IN/OUT): IN
- JP6(MICL_IN) : BNC
- JP8(MICR_IN) : BNC

(3) MICL/MICR pins are input from Pre-Amp output.

- JP1(PREL_RL) : Open
- JP3(PRER_RL) : Open
- JP4(L_IN/OUT): Open
- JP7(R_IN/OUT): Open
- JP6(MICL_IN): LOOP
- JP8(MICR_IN) : LOOP

3. Pre-Amp Input Circuit

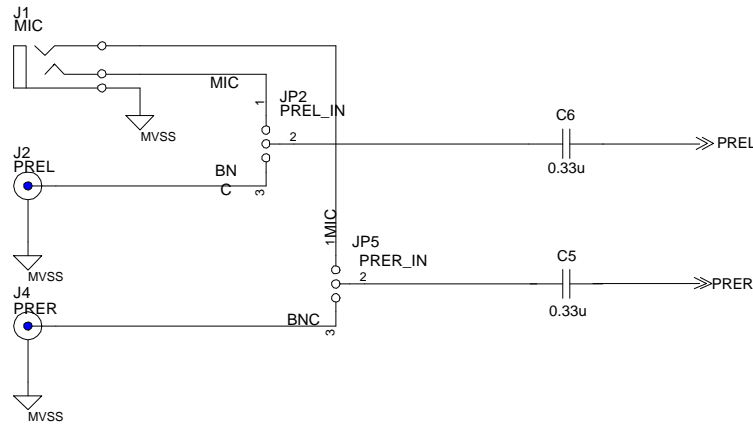

Figure 8. Pre-Amp Input Circuit

- (1) Analog signals are input to PREL/PRER pins via J1(MIC) mini-jack.
 JP2(PREL_IN): MIC
 JP5(PRER_IN): MIC

- (2) Analog signals are input to PREL/PRER pins via J2/J4 connectors.
 JP2(PREL): BNC
 JP5(PRER): BNC

*** AKM assumes no responsibility for the trouble when using the circuit examples.**

Control Software Manual

■ Set-up of evaluation board and control software

1. Set up the AKD5356 according to previous term.
2. Connect IBM-AT compatible PC with AKD5356 by 10-line type flat cable (packed with AKD5356). Take care of the direction of 10pin header. (This control software does not operate on Windows NT/2000/XP, therefore please operate it on Windows 95/98/ME.)
3. Insert the floppy-disk labeled “AKD5356 Control Program ver 1.0” into the floppy-disk drive.
4. Access the floppy-disk drive and double-click the icon of “akd5356.exe” to set up the control program.
5. Then please evaluate according to the follows.

■ Operation flow

Keep the following flow.

1. Set up the control program according to explanation above.
2. Click “Port Setup” button.
3. Click “Write default” button.
4. Then set up the dialog and input data.

■ Explanation of each buttons

1. [Port Setup] : Set up the printer port.
2. [Reset] : Initialize the register of AK5356.
3. [Function1] : Dialog to write data by keyboard operation.
4. [Function2] : Dialog to evaluate IPGA.
5. [Write] : Dialog to write data by mouse operation.

■ Explanation of each dialog

1. [Function1 Dialog]: Dialog to write data by keyboard operation

Address Box: Input register address in 2 figures of hexadecimal.

Data Box: Input register data in 2 figures of hexadecimal.

If you want to write the input data to AK5356, click “OK” button. If not, click “Cancel” button.

2. [Function2 Dialog] : Dialog to evaluate IPGA

This dialog corresponds to only addr=03H.

Address Box: Input register address in 2 figures of hexadecimal.

Start Data Box: Input start data in 2 figures of hexadecimal.

End Data Box: Input end data in 2 figures of hexadecimal.

Interval Box: Data is written to AK5356 by this interval.

Step Box: Data changes by this step.

Mode Select Box:

If you check this check box, data reaches end data, and returns to start data.

[Example] Start Data = 00, End Data = 09

Data flow: 00 01 02 03 04 05 06 07 08 09 09 08 07 06 05 04 03 02 01 00

If you do not check this check box, data reaches end data, but does not return to start data.

[Example] Start Data = 00, End Data = 09

Data flow: 00 01 02 03 04 05 06 07 08 09

If you want to write the input data to AK5356, click "OK" button. If not, click "Cancel" button.

3. [Write Dialog] : Dialog to write data by mouse operation

There are dialogs corresponding to each register.

Click the "Write" button corresponding to each register to set up the dialog. If you check the check box, data becomes "H" or "1". If not, "L" or "0".

If you want to write the input data to AK5356, click "OK" button. If not, click "Cancel" button.

■ Indication of data

Input data is indicated on the register map. Red letter indicates "H" or "1" and blue one indicates "L" or "0". Blank is the part that is not defined in the datasheet.

■ Attention on the operation

If you set up Function1 or Function2 dialog, input data to all boxes. Attention dialog is indicated if you input data or address that is not specified in the datasheet or you click "OK" button before you input data. In that case set up the dialog and input data once more again. These operations does not need if you click "Cancel" button or check the check box.

IMPORTANT NOTICE

- These products and their specifications are subject to change without notice. Before considering any use or application, consult the Asahi Kasei Microsystems Co., Ltd. (AKM) sales office or authorized distributor concerning their current status.
- AKM assumes no liability for infringement of any patent, intellectual property, or other right in the application or use of any information contained herein.
- Any export of these products, or devices or systems containing them, may require an export license or other official approval under the law and regulations of the country of export pertaining to customs and tariffs, currency exchange, or strategic materials.
- AKM products are neither intended nor authorized for use as critical components in any safety, life support, or other hazard related device or system, and AKM assumes no responsibility relating to any such use, except with the express written consent of the Representative Director of AKM. As used here:
 - (a) A hazard related device or system is one designed or intended for life support or maintenance of safety or for applications in medicine, aerospace, nuclear energy, or other fields, in which its failure to function or perform may reasonably be expected to result in loss of life or in significant injury or damage to person or property.
 - (b) A critical component is one whose failure to function or perform may reasonably be expected to result, whether directly or indirectly, in the loss of the safety or effectiveness of the device or system containing it, and which must therefore meet very high standards of performance and reliability.
- It is the responsibility of the buyer or distributor of an AKM product who distributes, disposes of, or otherwise places the product with a third party to notify that party in advance of the above content and conditions, and the buyer or distributor agrees to assume any and all responsibility and liability for and hold AKM harmless from any and all claims arising from the use of said product in the absence of such notification.

MEASUREMENT RESULTS EXAMPLE

[Measurement Condition]

- Measurement Units: Audio Precision, Cascade
- MCKI: 256fs
- Bit: 20bit
- Sampling Frequency: 44.1kHz
- Measurement Frequency: 10 ~ 20kHz
- Power Supply: MVDD = 2.7V, AVDD = DVDD = 2.5V
- Temperature: Room
- Input Frequency: 1kHz
- Interface: DIT

[Measurement Results]

1. Pre-Amp Characteristics (PREL/PRER → PREOL/PREOR)

Parameter	Pre-Amp Gain	Results	Additional Filter
S/(N+D) (Vout = -29.2dBV)	+33dB	60dB	
	+28dB	65dB	
	+18dB	74dB	
	+13dB	78dB	
Output Noise Level (Rg = 600Ω)	+33dB	-91dBV	A-weighted
	+28dB	-96dBV	A-weighted
	+18dB	-105dBV	A-weighted
	+13dB	-109dBV	A-weighted

2. ADC Characteristics (LINE → ADC)

Parameter	Results		Additional Filter
	IPGA = 0dB	IPGA = +28dB	
S/(N+D) (-0.5dBFS)	84dB	74dB	
DR (-60dBFS)	89dB	79dB	A-weighted
S/N	89dB	79dB	A-weighted

[Plot]

1. Pre-Amp (PREL/PRER → PREOL/PREOR)

AKM

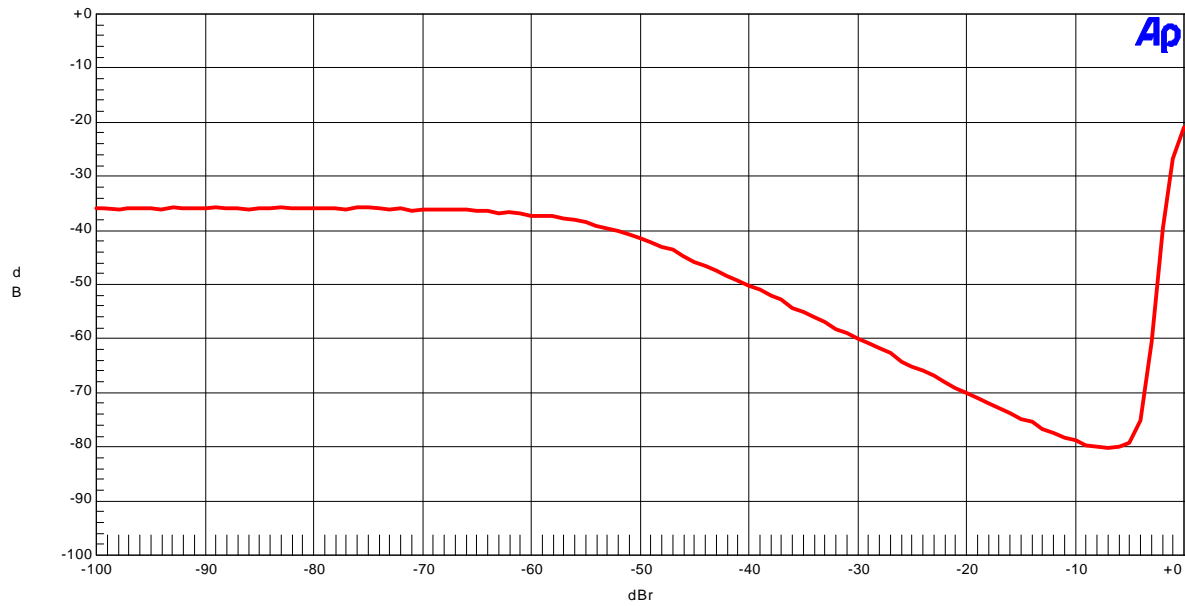

Figure 9. THD+N vs. Output Level (Gain = +33dB, fin = 1kHz, 0dBr = 0dBV)

AKM

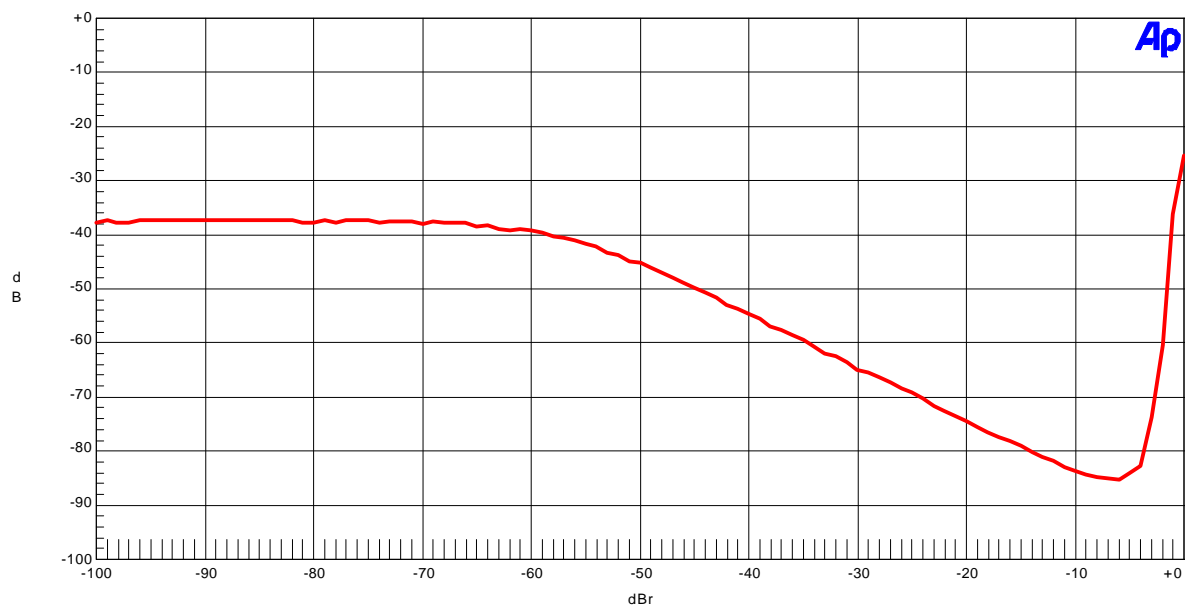

Figure 10. THD+N vs. Output Level (Gain = +28dB, fin = 1kHz, 0dBr = 0dBV)

AKM

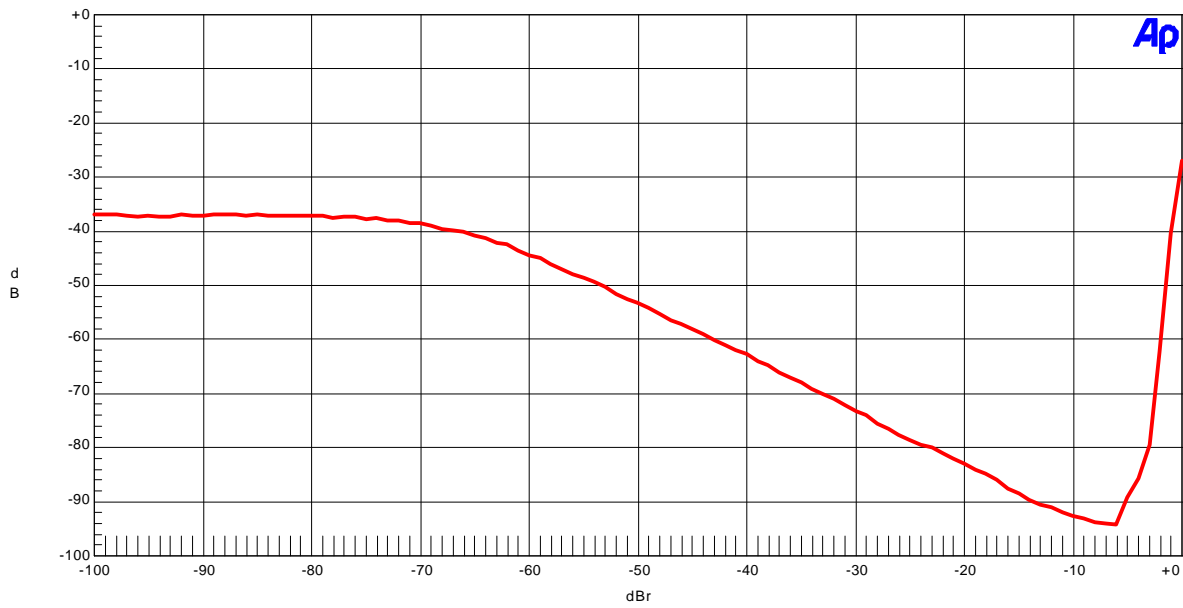

Figure 11. THD+N vs. Output Level (Gain = +18dB, fin = 1kHz, 0dBr = 0dBV)

AKM

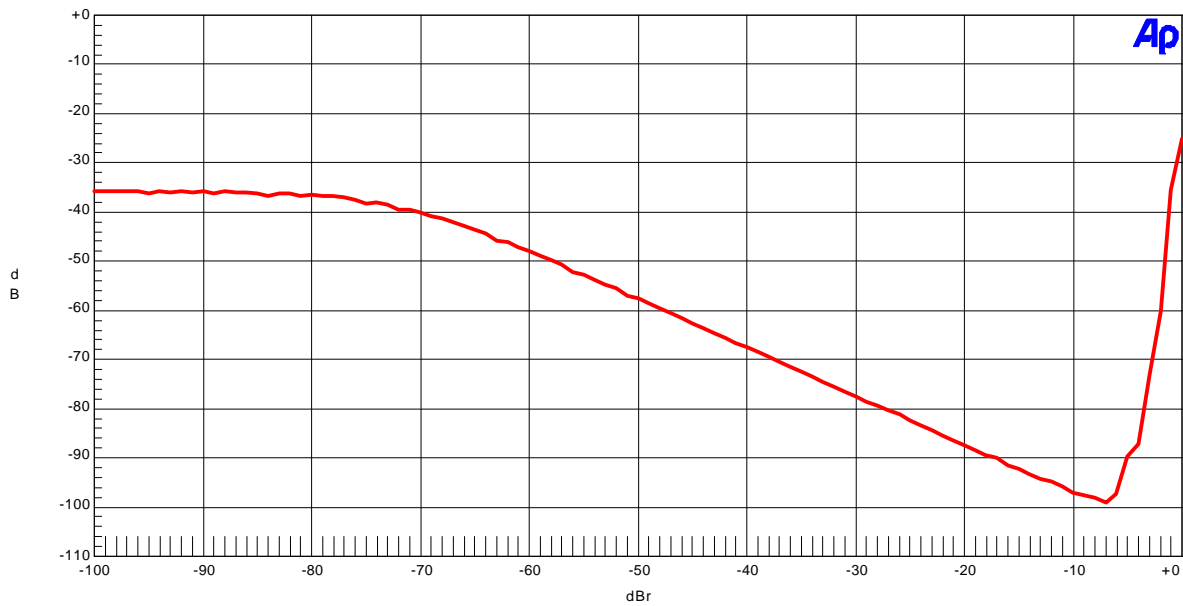

Figure 12. THD+N vs. Output Level (Gain = +13dB, fin = 1kHz, 0dBr = 0dBV)

AKM

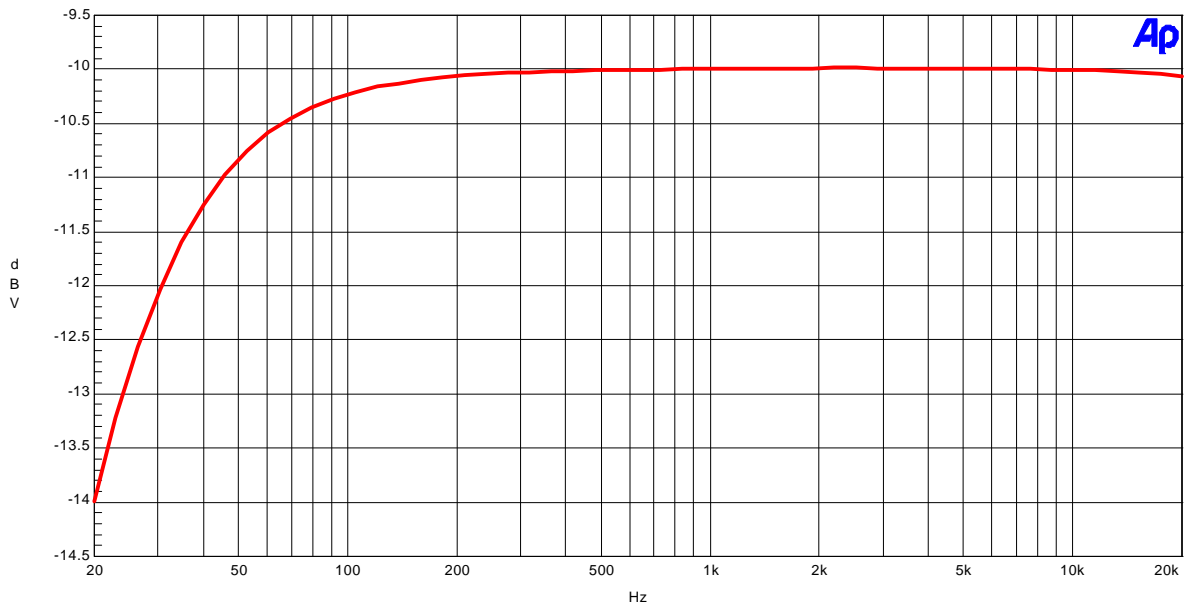

Figure 13. Frequency Response (Gain = +33dB, ref = -10dBV output @ 1kHz)

AKM

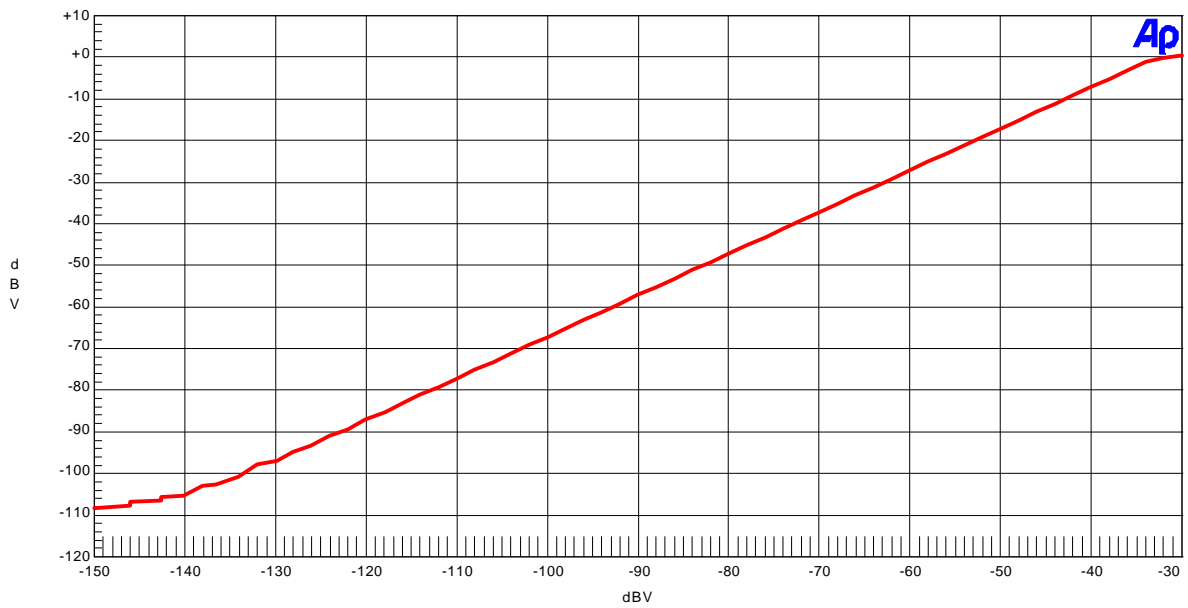

Figure 14. Linearity (Gain = +33dB, fin = 1kHz)

AKM

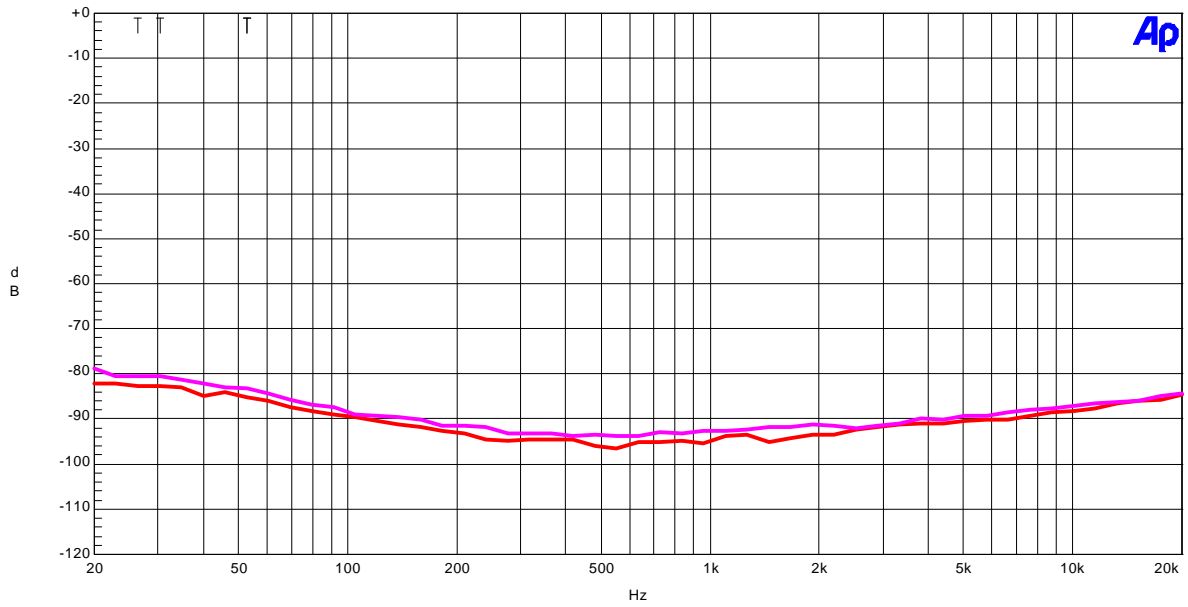

Figure 15. Crosstalk (Gain = +33dB)

AKM

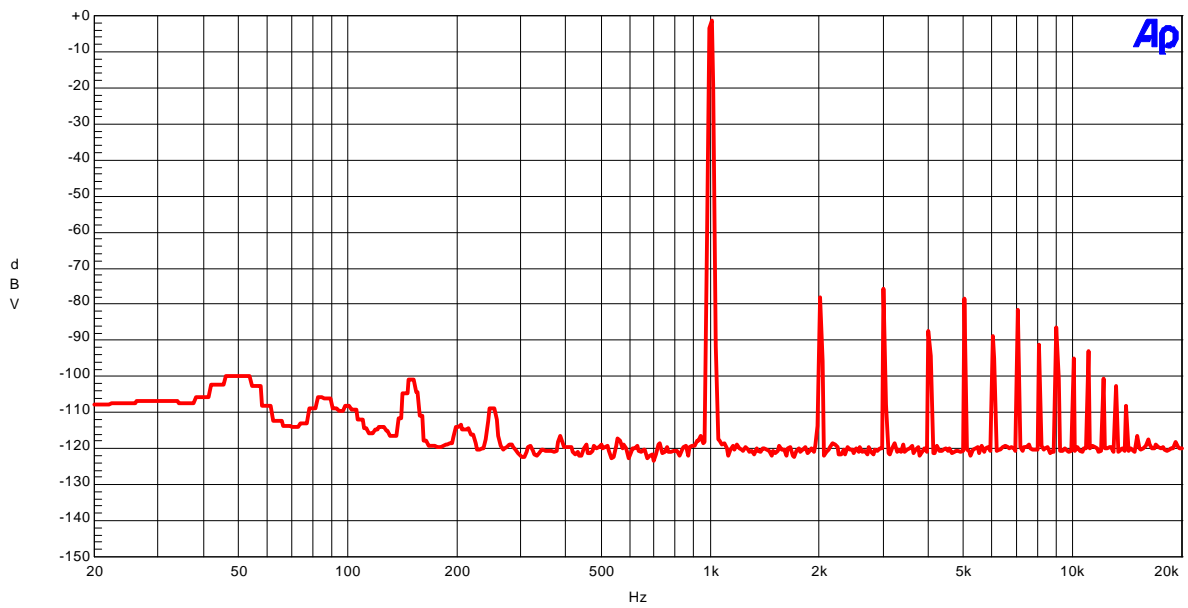

Figure 16. FFT plot (Gain = +33dB, Output Level = -1.5dBV)

AKM

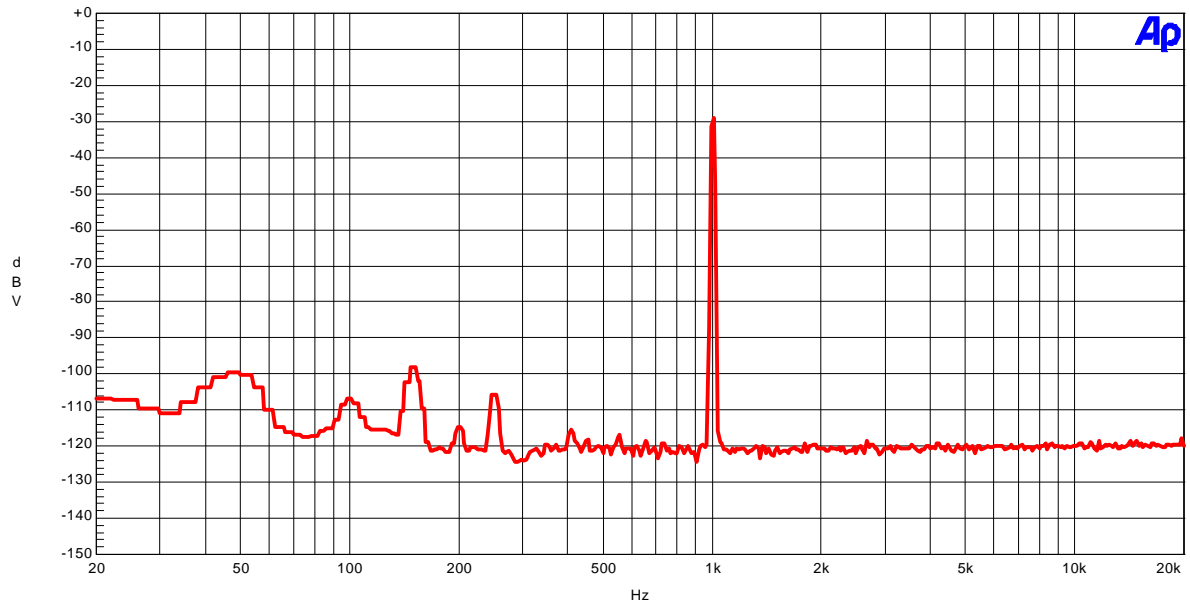

Figure 17. FFT plot (Gain = +33dB, Output Level = -29.2dBV)

AKM

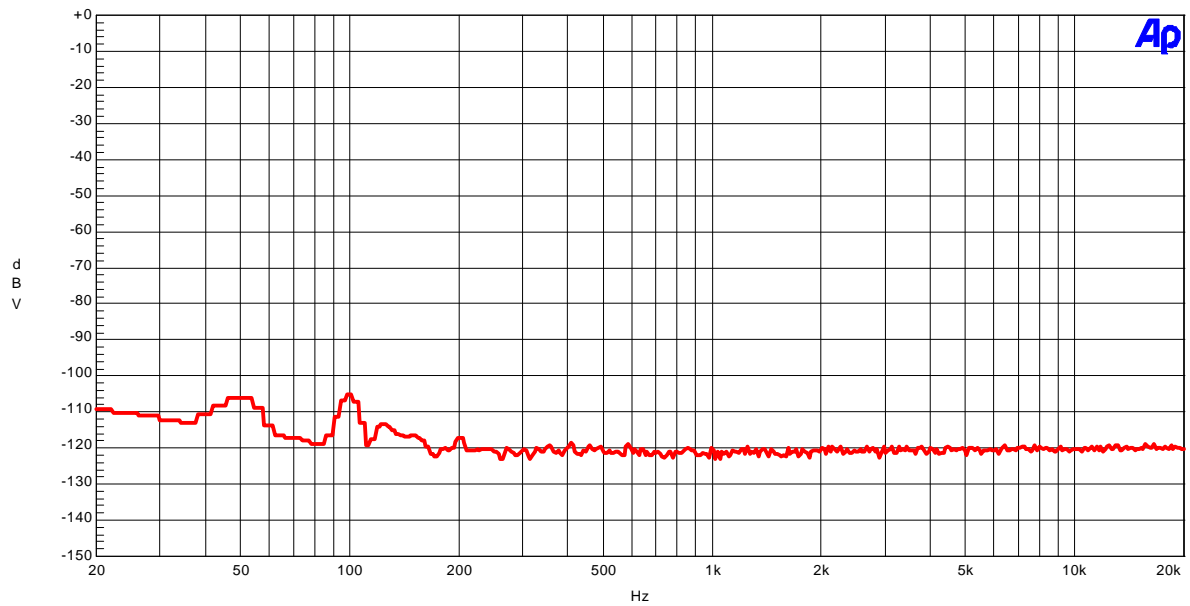

Figure 18. FFT plot (Gain = +28dB, No input signal, Rg=600Ω)

2. Line → ADC (IPGA = 0dB)

AKM

AK5356 ADC THD+N vs. Input Level (fs=44.1kHz, fin=1kHz) Line --->ADC

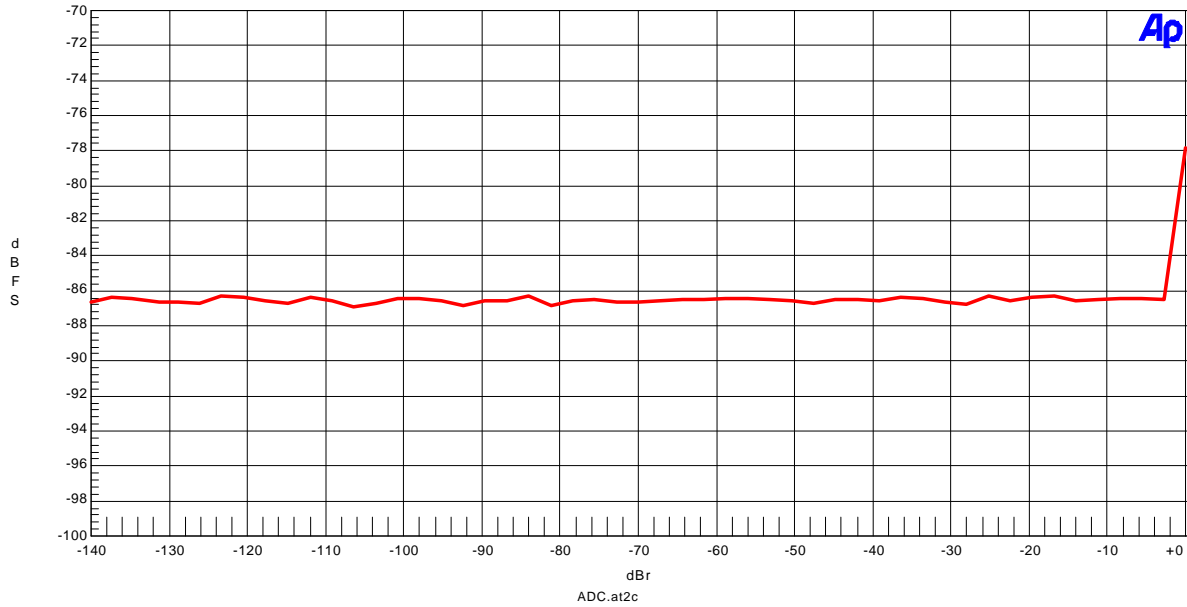

Figure 19. THD+N vs. Input Level

AKM

AK5356 ADC THD+N vs. Input Frequency (fs=44.1kHz, -0.5dB input) Line --->ADC

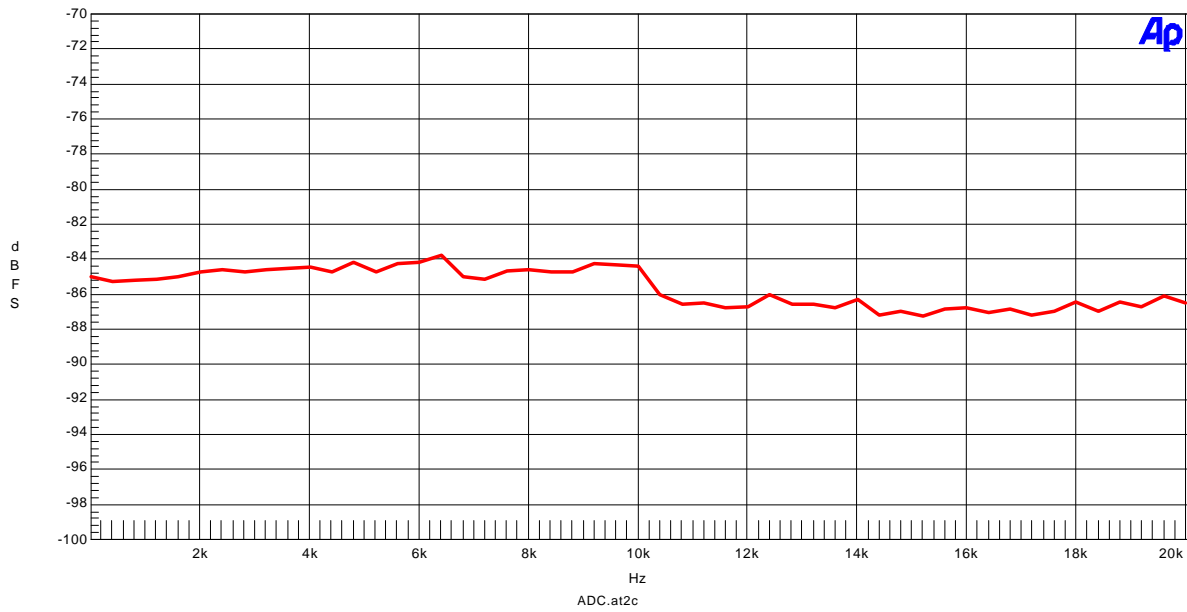

Figure 20. THD+N vs. Input Frequency (-0.5dBFS Input)

AKM

AK5356 ADC Linearity($f_s=44.1\text{kHz}$, $f_{in}=1\text{kHz}$) Line --->ADC

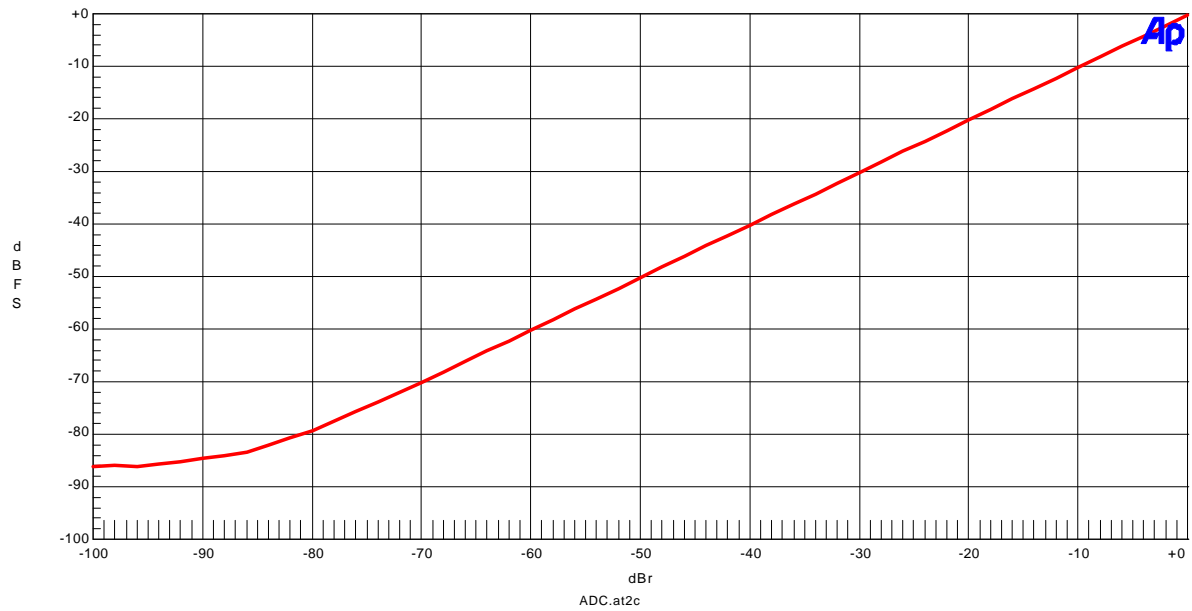

Figure 21. Linearity ($f_{in}=1\text{kHz}$)

AKM

AK5356 ADC Frequency Response($f_s=44.1\text{kHz}$, -0.5dBr input) Line --->ADC

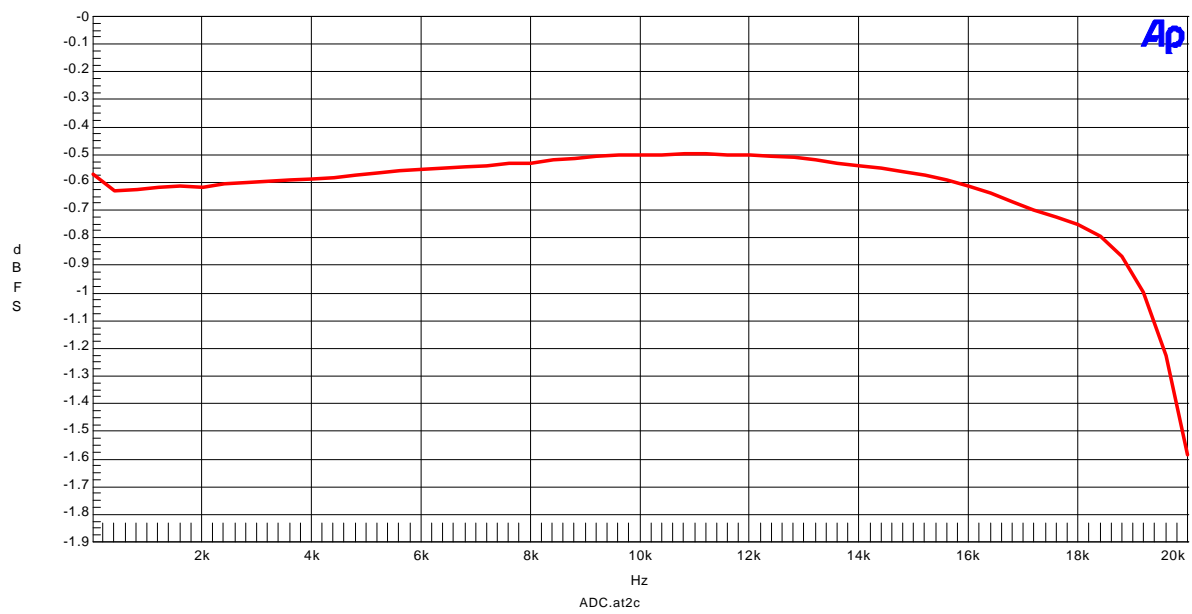

Figure 22. Frequency Response

AKM

AK5356 ADC Crosstalk(fs=44.1kHz, -0.5dB_r input) Line --->ADC
Upper@1kHz; Rch--->Lch, Lower@1kHz; Lch--->Rch

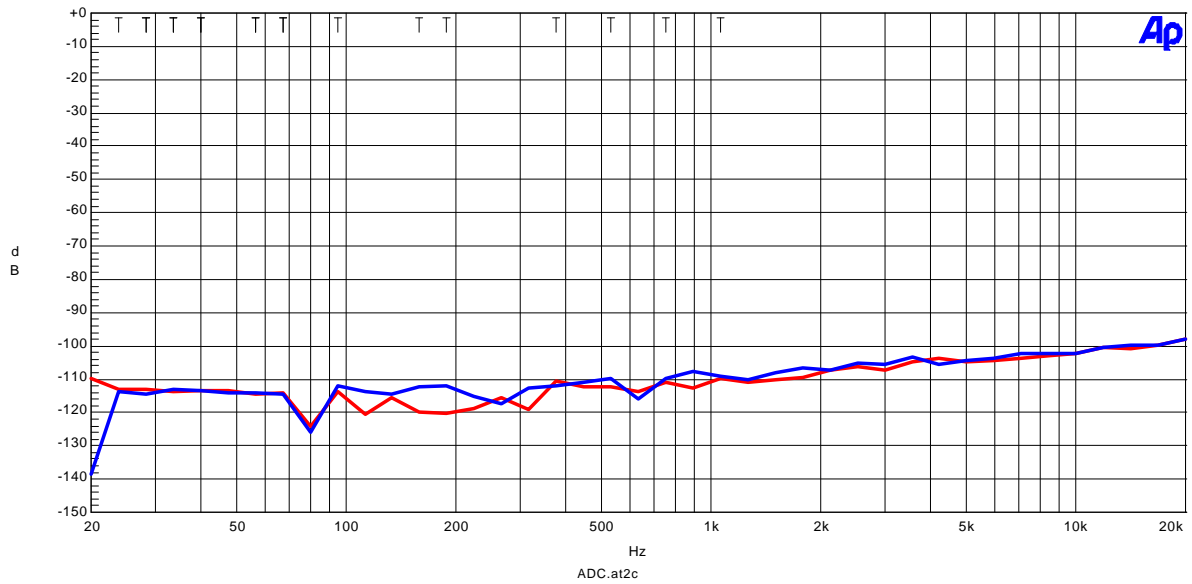

Figure 23. Crosstalk

AKM

AK5356 ADC FFT(fs=44.1kHz, fin=1kHz, -0.5dB_r input) Line --->ADC

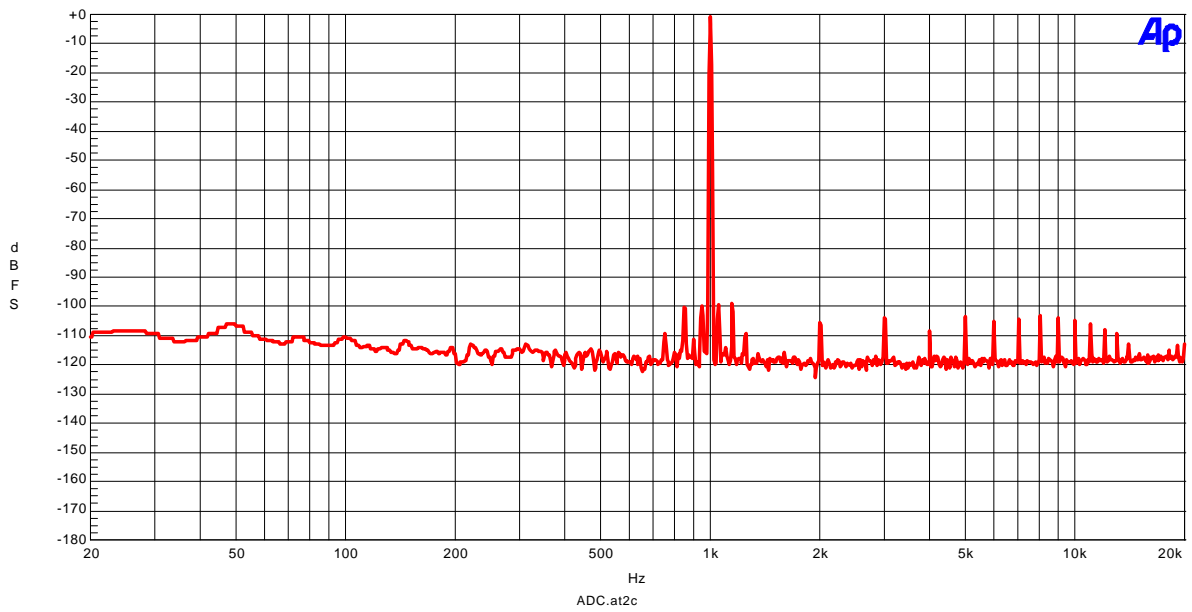

Figure 24. FFT plot (-0.5dBFS Input)

AKM

AK5356 ADC FFT(fs=44.1kHz, fin=1kHz, -60dB_r input) Line --->ADC

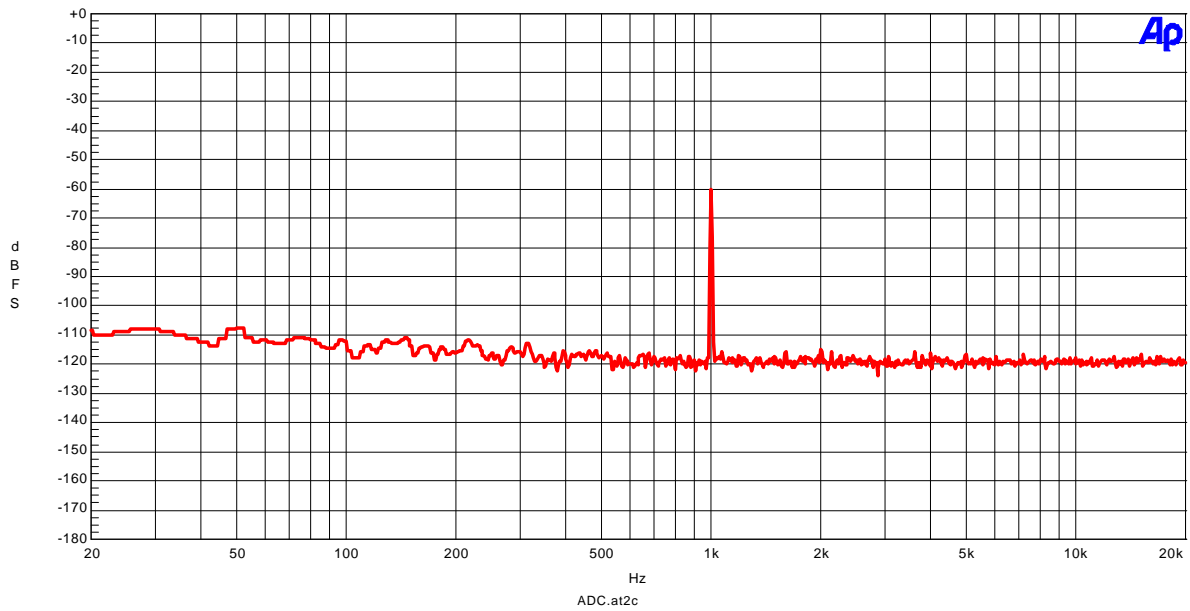

Figure 25. FFT plot (-60dBFS Input)

AKM

AK5356 ADC FFT(No signal input) Line --->ADC

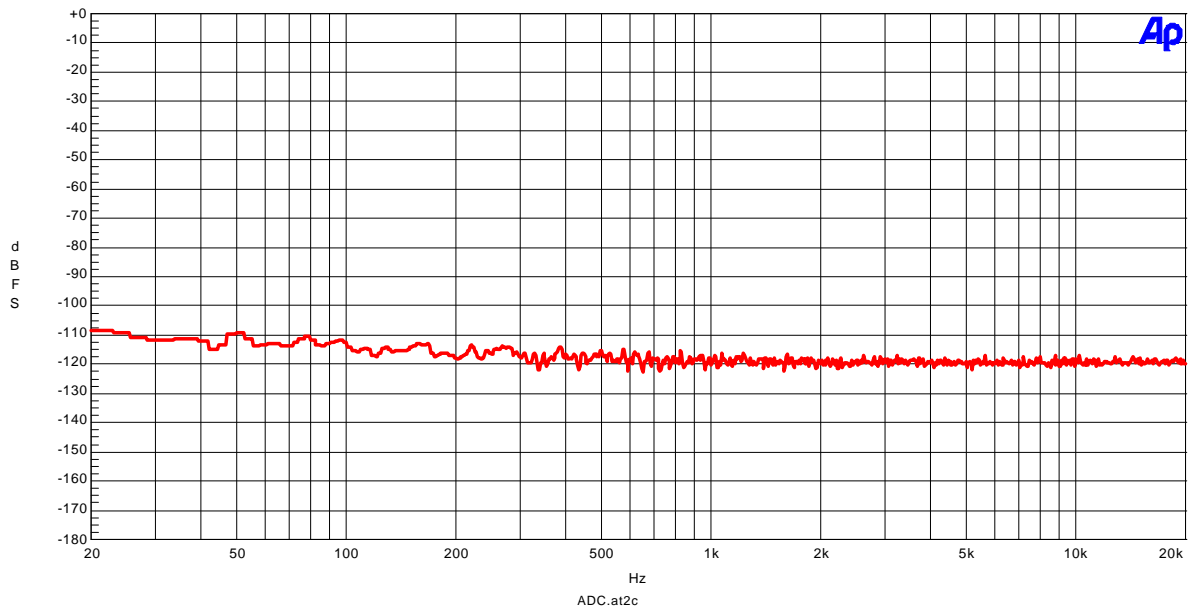
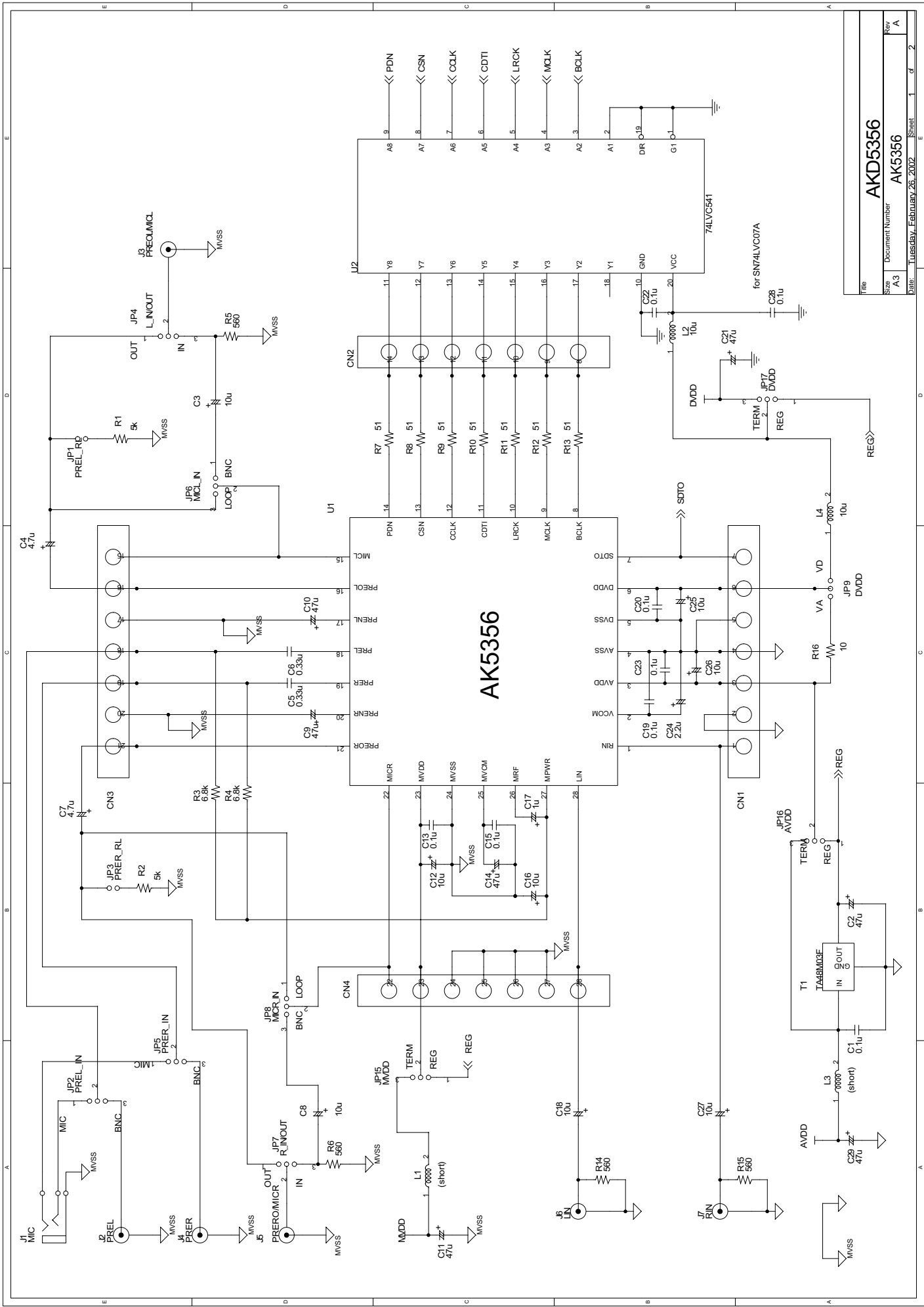
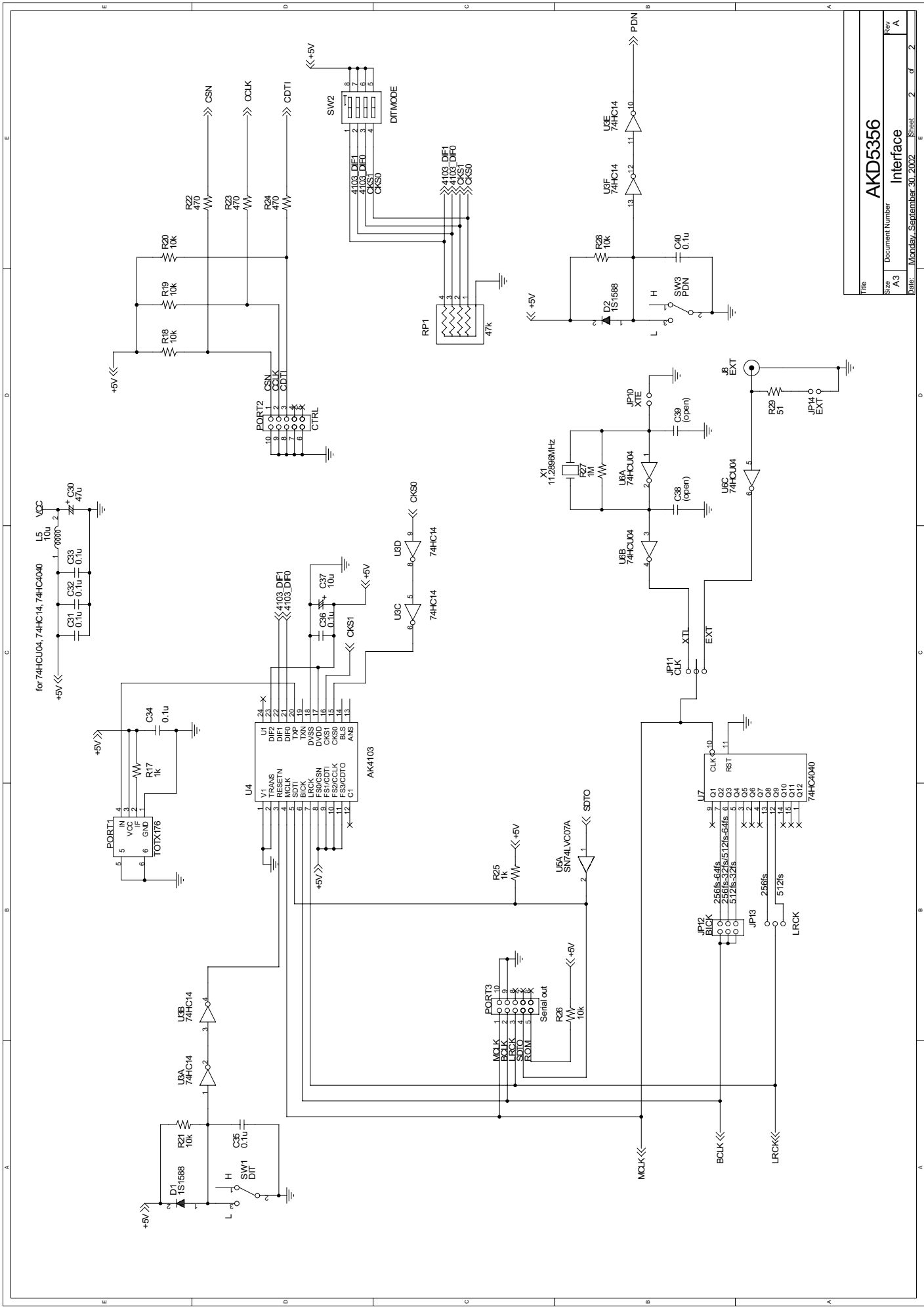

Figure 26. FFT plot (Noise Floor)



File	AKD5356
Size	Document Number
Rev	AK5356
Date	Tuesday, February 26, 2002
Sheet	1 of 2



Title		AKD5356	
Size	Document Number	Interface	
Rev	Date	Monday, September 30, 2002	Sheet 2 of 2
A			

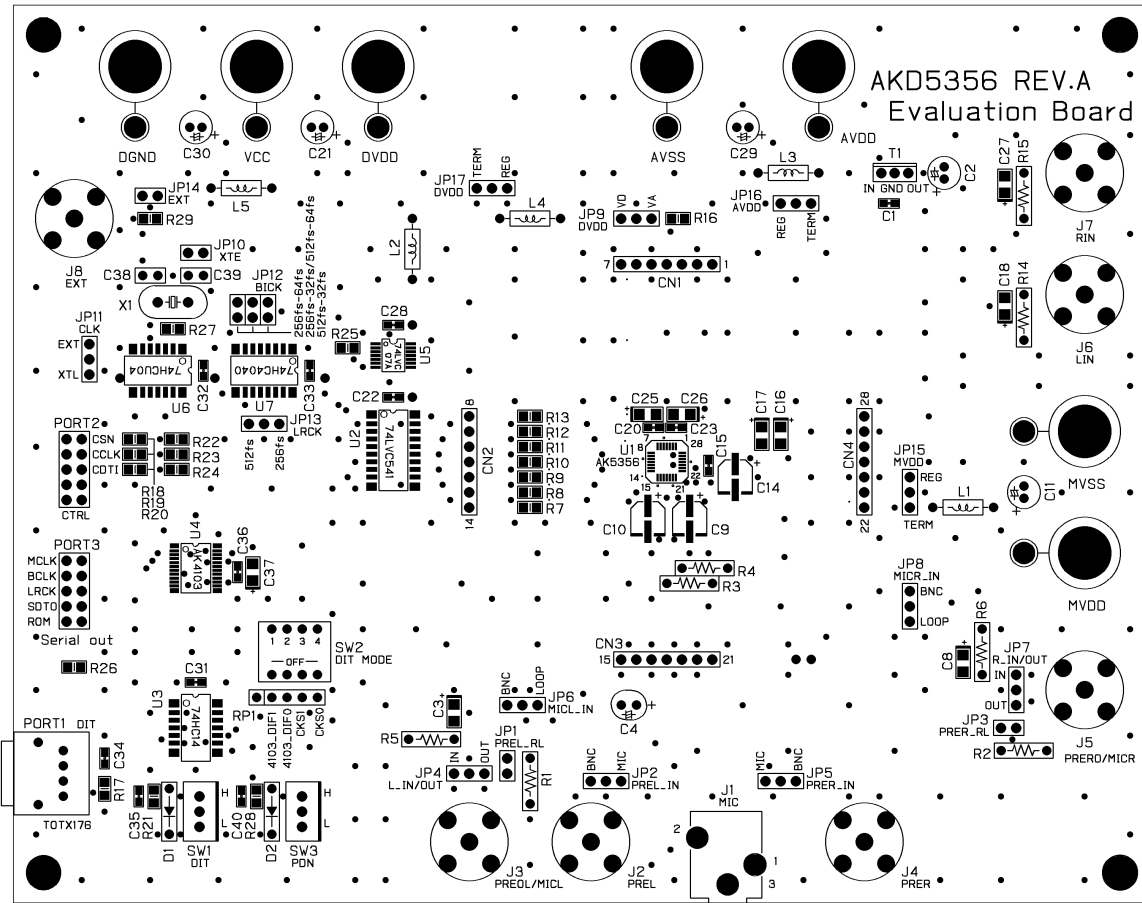

AKD5356 REV.A
Evaluation Board

AKD5356 Rev.A L1 SR SILK

AKD32E Rev.A LS 2R SILK

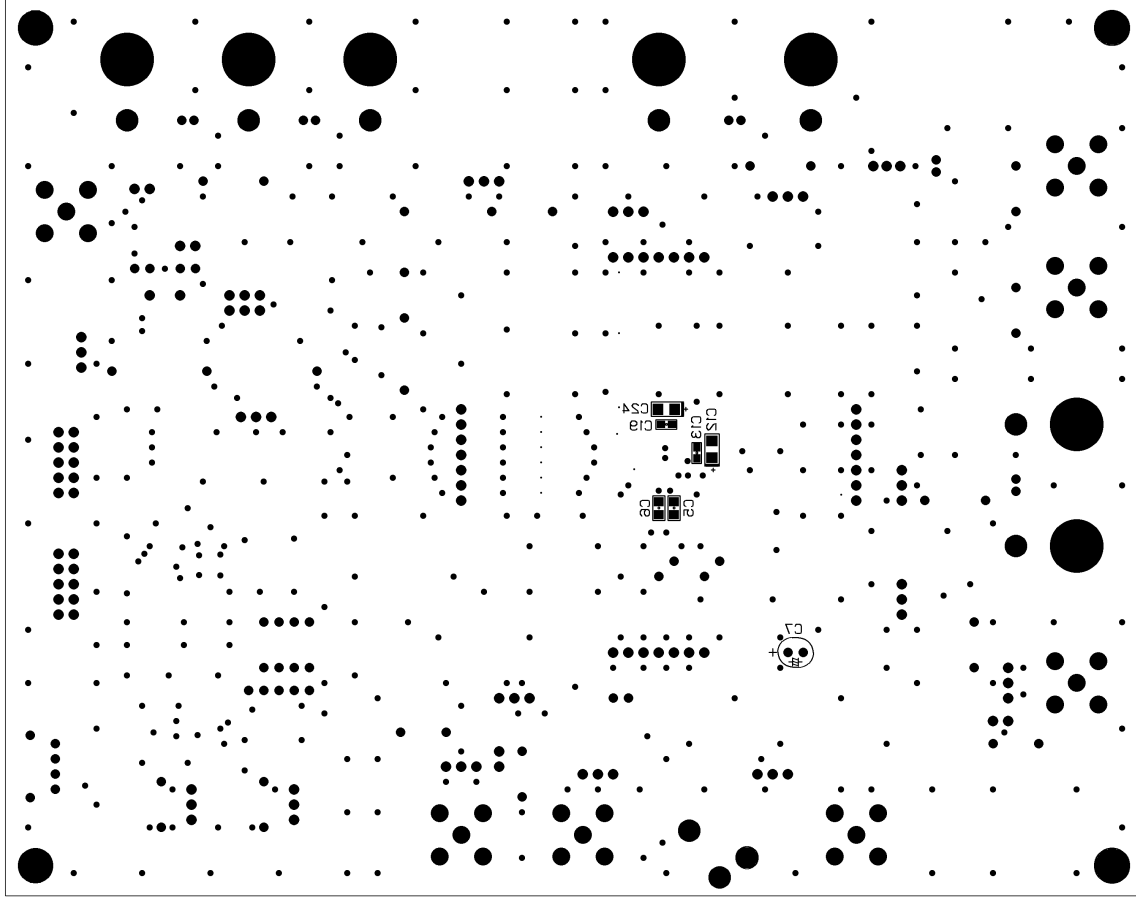

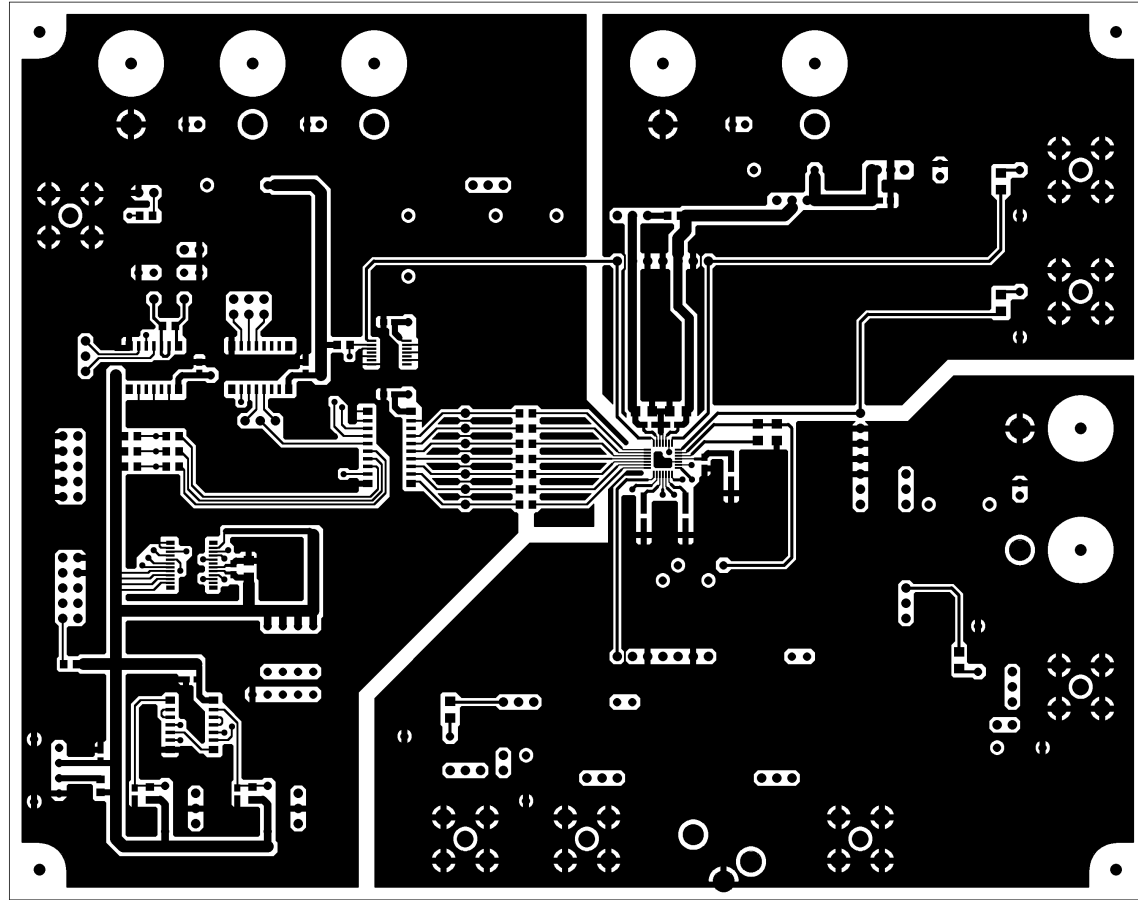

AKD5356 Rev.A L1

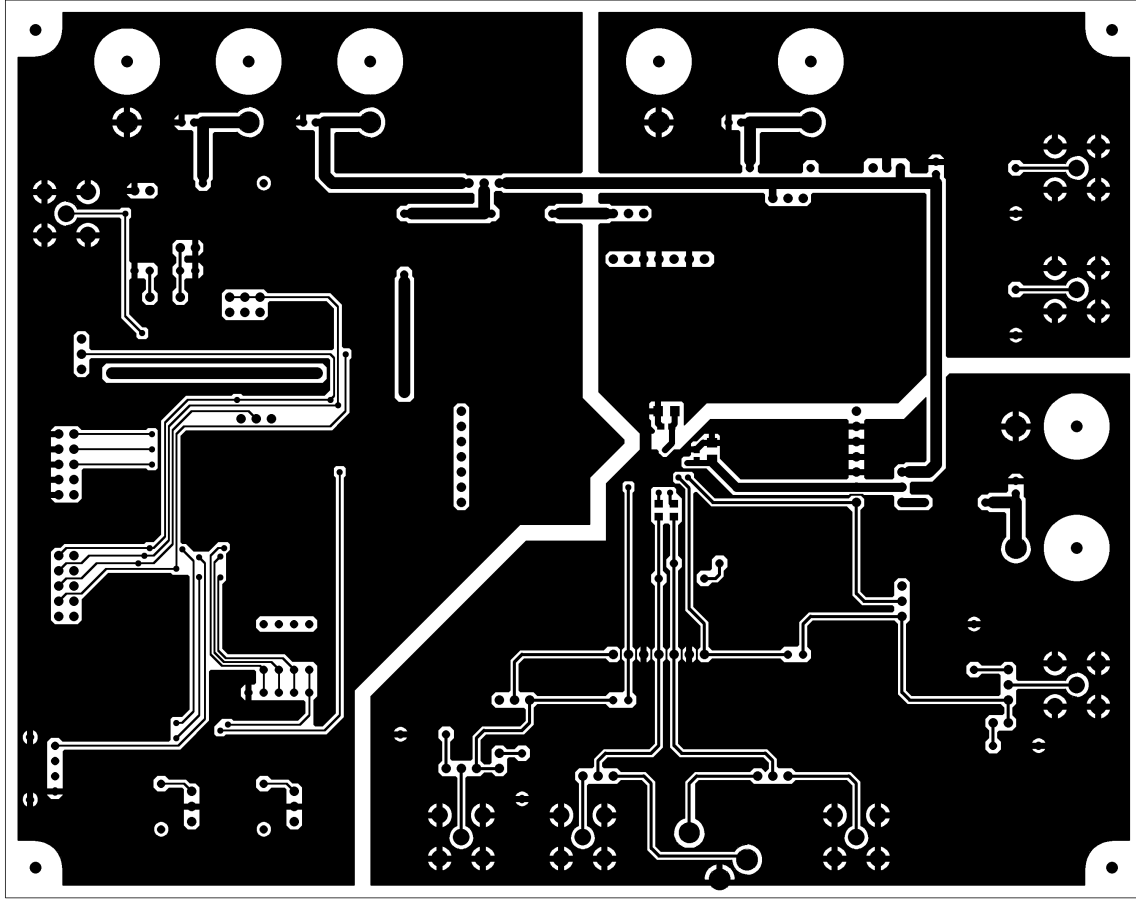

AKD232E Rev.A LS