

## General Description

The AOZ8906 is a transient voltage suppressor array designed to protect high speed data lines such as HDMI, USB 2.0, MDDI, SATA, and Gigabit Ethernet from damaging ESD events.

This device incorporates eight surge rated, low capacitance steering diodes and a TVS in a single package. During transient conditions, the steering diodes direct the transient to either the positive side of the power supply line or to ground.

The AOZ8906 provides a typical line to line capacitance of 1pF making it ideally suited for HDMI 1.3 or USB 2.0 applications, such as Digital TVs, DVD players, Computing, set-top boxes and MDDI applications in mobile computing devices.

The AOZ8906 comes in RoHS compliant and halogen free SOT23-6L package and is rated -40°C to +85°C junction temperature range.

## Features

- ESD protection for high-speed data lines:
  - IEC 61000-4-2, level 4 (ESD) immunity test
  - ±30kV (air discharge) and ±30kV (contact discharge)
  - IEC61000-4-4 (EFT) 40A (5/50nS)
  - IEC61000-4-5 (Lightning) 7A (8/20µS)
  - Human Body Model (HBM) ±30kV
- Array of surge rated diodes with internal TVS diode
- Protects four I/O lines
- Low capacitance between I/O lines: 1pF
- Low clamping voltage
- Low operating voltage: 5.0V

## Applications

- HDMI, USB 2.0, MDDI, SATA ports
- Monitors and flat panel displays
- Set-top box
- Video graphics cards
- Notebook computers



## Typical Application

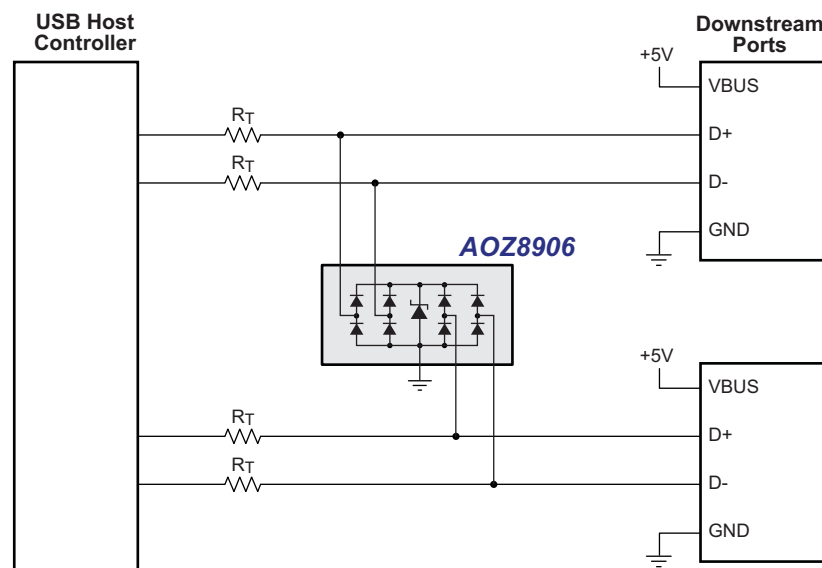

Figure 1. USB High Speed Ports

## Ordering Information

Part Number	Ambient Temperature Range	Package	Environmental
AOZ8906CI	-40°C to +85°C	SOT23-6L	RoHS Compliant Green Product



AOS Green Products use reduced levels of Halogens, and are also RoHS compliant. Please visit [www.aosmd.com/media/AOSGreenPolicy.pdf](http://www.aosmd.com/media/AOSGreenPolicy.pdf) for additional information.

## Pin Configuration

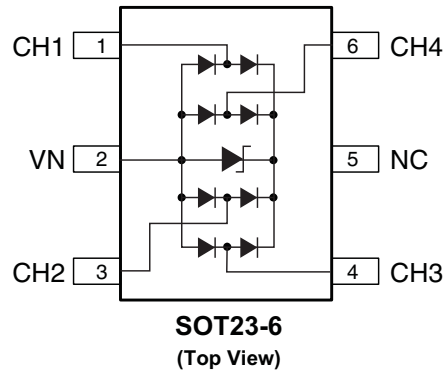

## Absolute Maximum Ratings

Exceeding the Absolute Maximum ratings may damage the device.

Parameter	Rating
Storage Temperature ( $T_S$ )	-65°C to +150°C
ESD Rating per IEC61000-4-2, contact <sup>(1)</sup>	±30kV
ESD Rating per IEC61000-4-2, air <sup>(1)</sup>	±30kV
ESD Rating per Human Body Model <sup>(2)</sup>	±30kV

### Notes:

- IEC 61000-4-2 discharge with  $C_{Discharge} = 150\text{pF}$ ,  $R_{Discharge} = 330\Omega$ .
- Human Body Discharge per MIL-STD-883, Method 3015  $C_{Discharge} = 100\text{pF}$ ,  $R_{Discharge} = 1.5\text{k}\Omega$ .

## Maximum Operating Ratings

Parameter	Rating
Junction Temperature ( $T_J$ )	-40°C to +125°C

## Electrical Characteristics

$T_A = 25^\circ\text{C}$  unless otherwise specified.

Symbol	Parameter	Conditions	Min.	Typ.	Max.	Units
$V_{RWM}$	Reverse Working Voltage	Between I/O and VN <sup>(3)</sup>			5.5	V
$V_{BR}$	Reverse Breakdown Voltage	$I_T = 100\mu\text{A}$ , between I/O and VN <sup>(4)</sup>	6.6			V
$I_R$	Reverse Leakage Current	$V_{RWM} = 5\text{V}$ , between I/O and VN			1.0	$\mu\text{A}$
$V_F$	Diode Forward Voltage	$I_F = 15\text{mA}$	0.7	0.85	1.0	V
$V_{CL}$	Channel Clamp Voltage Positive Transients Negative Transients	$I_{PP} = 16\text{A}$ , $t_p = 100\text{ns}$ , any I/O pin to Ground <sup>(5)</sup>			4.1 -5.3	V
	Channel Clamp Voltage Positive Transients Negative Transients	$I_{PP} = 30\text{A}$ , $t_p = 100\text{ns}$ , any I/O pin to Ground <sup>(5)</sup>			5.2 -9.9	V
	Channel Clamp Voltage Any I/O Pin to Ground	$I_{PP} = 7\text{A}$ , $t_p = 8/20\mu\text{s}$			8	V
$C_j$	Channel Input Capacitance	$V_R = 0\text{V}$ , $f = 1\text{MHz}$ , any I/O pin to Ground		1.0	1.5	pF
		$V_R = 0\text{V}$ , $f = 1\text{MHz}$ , between I/O pins		0.5	0.8	pF
$R_{DYN}$	Dynamic Resistance	$I_{TLP} = 16\text{A to }30\text{A}$		0.15		$\Omega$
		$I_{TLP} = -16\text{A to }-30\text{A}$		0.3		$\Omega$

### Notes:

- The working peak reverse voltage,  $V_{RWM}$ , should be equal to or greater than the DC or continuous peak operating voltage level.
- $V_{BR}$  is measured at the pulse test current  $I_T$ .
- Measurements performed using a 100ns Transmission Line Pulse (TLP) system.

## Typical Performance Characteristics

**TLP Current vs. Clamping Voltage**  
(tperiod = 100ns, tr = 1ns)

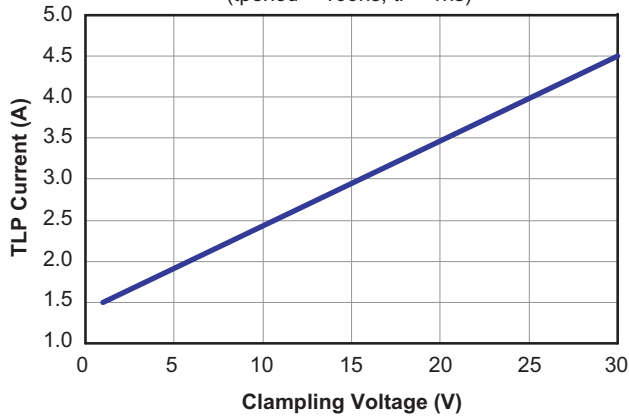

**Forward Voltage vs. Forward Current**  
(tperiod = 100nS, tr = 1ns)

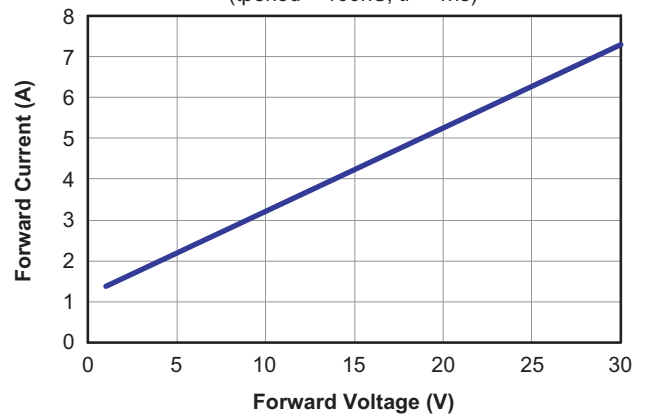

**Typical Variation of CIN vs. VR**  
(f = 1MHz, T = 25°C)

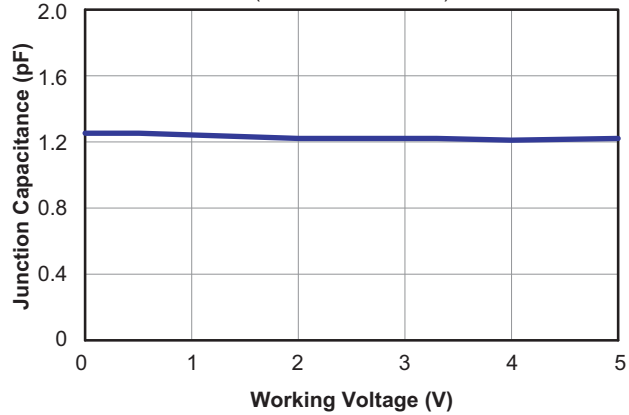

**+8kV ESD Clamping Per IEC 61000-4-2**  
(Contact, Between I/O to GND)

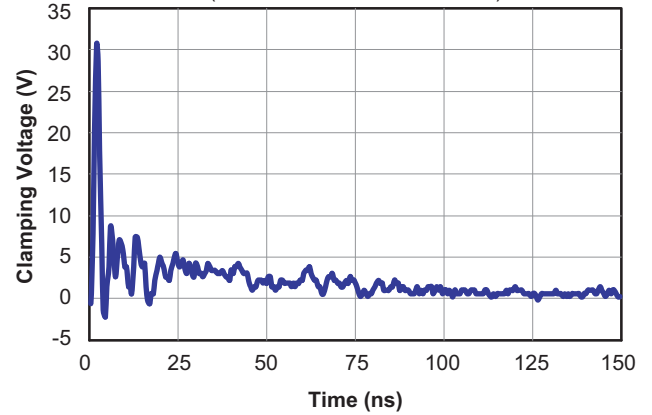

**-8kV ESD Clamping Per IEC 61000-4-2**  
(Contact, Between I/O to GND)

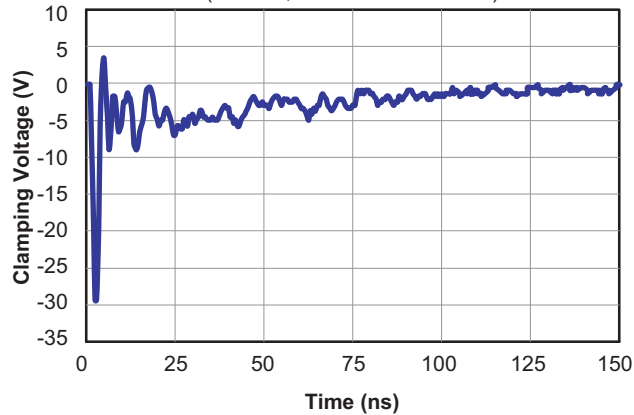

Package Dimensions, SOT23-6L

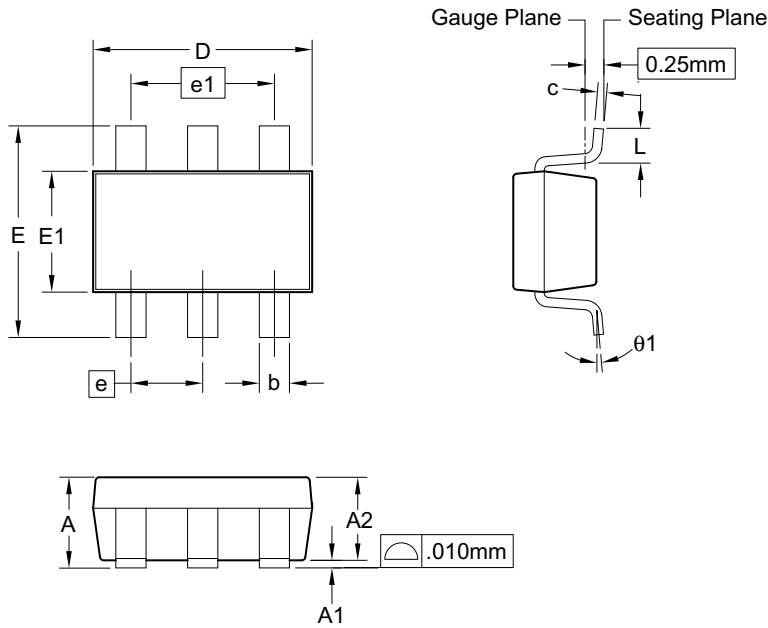

RECOMMENDED LAND PATTERN

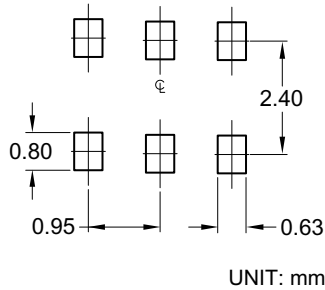

Dimensions in millimeters

Symbols	Min.	Nom.	Max.
A	0.90	—	1.25
A1	0.00	—	0.15
A2	0.80	1.10	1.20
b	0.30	0.40	0.50
c	0.08	0.13	0.20
D	2.70	2.90	3.10
E	2.50	2.80	3.10
E1	1.50	1.60	1.70
e	0.95 BSC		
e1	1.90 BSC		
L	0.30	—	0.60
θ1	0°	—	8°

Dimensions in inches

Symbols	Min.	Nom.	Max.
A	0.035	—	0.049
A1	0.00	—	0.006
A2	0.031	0.043	0.047
b	0.012	0.016	0.020
c	0.003	0.005	0.008
D	0.106	0.114	0.122
E	0.098	0.110	0.122
E1	0.059	0.063	0.067
e	0.037 BSC		
e1	0.075 BSC		
L	0.012	—	0.024
θ1	0°	—	8°

Notes:

1. Package body sizes exclude mold flash and gate burrs. Mold flash at the non-lead sides should be less than 5 mils each.
2. Dimension "L" is measured in gauge plane.
3. Tolerance ±0.100mm (4 mil) unless otherwise specified.
4. Followed from JEDEC MO-178C & MO-193C.
6. Controlling dimension is millimeter. Converted inch dimensions are not necessarily exact.

### Tape and Reel Dimensions, SOT23-6L

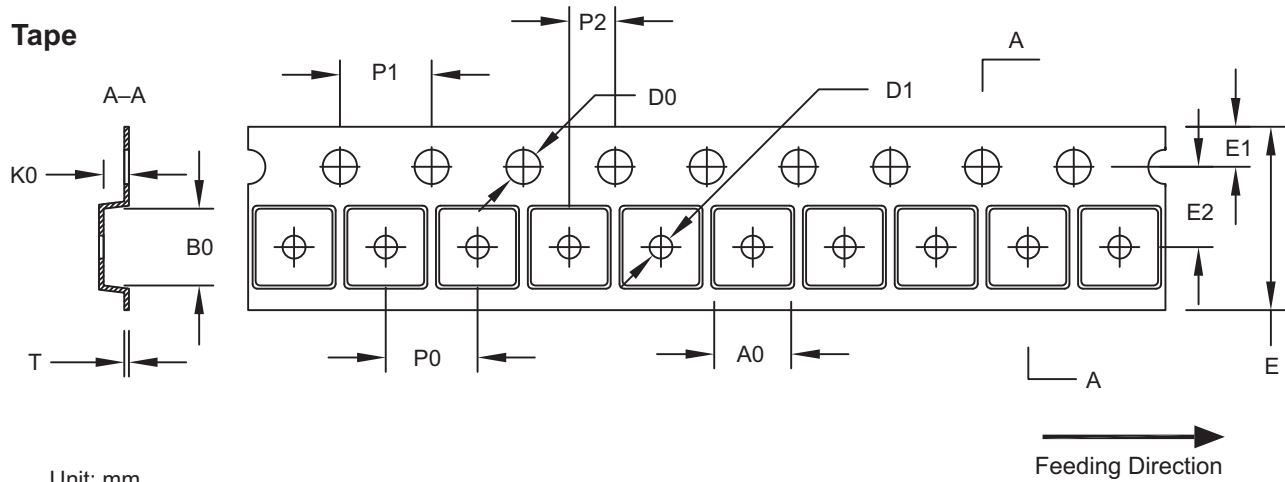

Unit: mm

Package	A0	B0	K0	D0	D1	E	E1	E2	P0	P1	P2	T
SOT-23	3.15 ±0.10	3.20 ±0.10	1.40 ±0.10	1.50 ±0.05	1.00 ±0.10/-0.0	8.00 ±0.30	1.75 ±0.10	3.50 ±0.05	4.00 ±0.10	4.00 ±0.10	2.00 ±0.05	0.23 ±0.03

### Reel

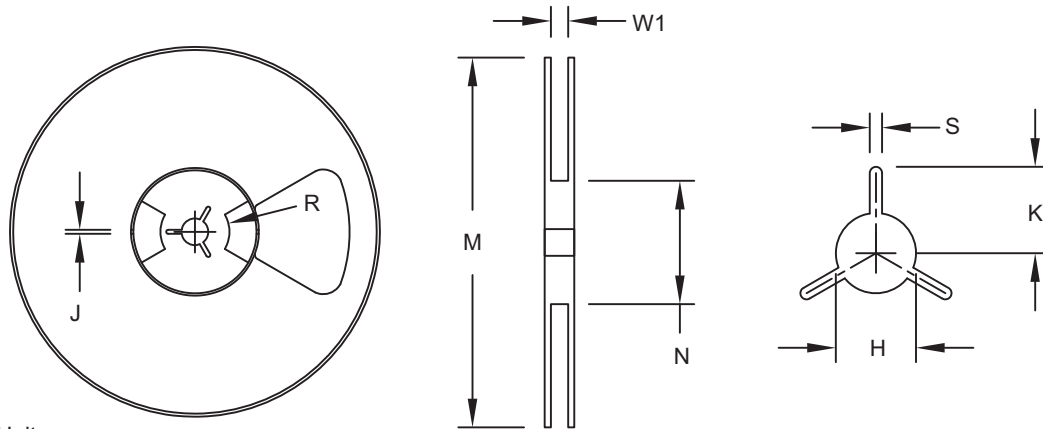

Unit: mm

Tape Size	Reel Size	M	N	W1	H	S	K	R	J
8 mm	ø177.80	ø177.80 MAX.	ø55.00 MIN.	8.40 +1.50/-0.00	ø13.00 +0.50 / -0.20	1.50 MIN.	10.10 MIN.	12.70	4.00 +0.10/-0.10

### Leader/Trailer and Orientation

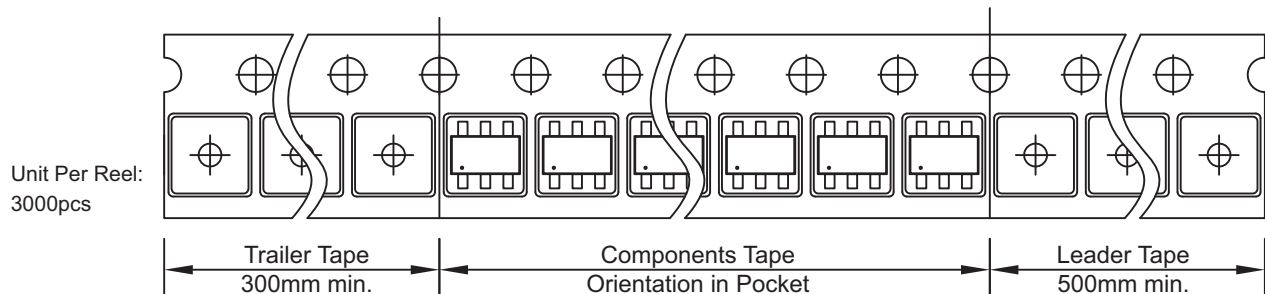

## Package Marking

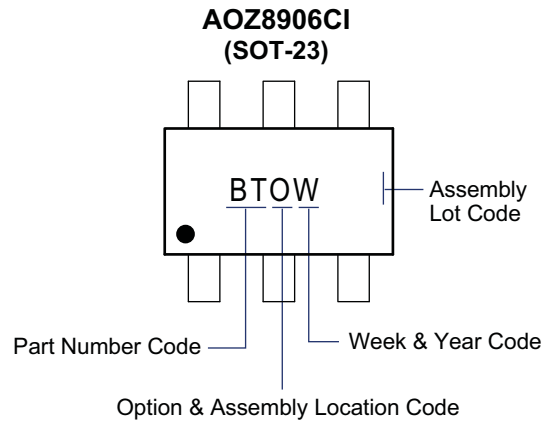

### LEGAL DISCLAIMER

Alpha and Omega Semiconductor makes no representations or warranties with respect to the accuracy or completeness of the information provided herein and takes no liabilities for the consequences of use of such information or any product described herein. Alpha and Omega Semiconductor reserves the right to make changes to such information at any time without further notice. This document does not constitute the grant of any intellectual property rights or representation of non-infringement of any third party's intellectual property rights.

### LIFE SUPPORT POLICY

ALPHA AND OMEGA SEMICONDUCTOR PRODUCTS ARE NOT AUTHORIZED FOR USE AS CRITICAL COMPONENTS IN LIFE SUPPORT DEVICES OR SYSTEMS.

As used herein:

1. Life support devices or systems are devices or systems which, (a) are intended for surgical implant into the body or (b) support or sustain life, and (c) whose failure to perform when properly used in accordance with instructions for use provided in the labeling, can be reasonably expected to result in a significant injury of the user.
2. A critical component in any component of a life support, device, or system whose failure to perform can be reasonably expected to cause the failure of the life support device or system, or to affect its safety or effectiveness.