

Angle Sensor

GMR-Based Angle Sensor

TLE5012B

Data Sheet

Rev. 2.0, 2014-02

Revision History

Page or Item	Subjects (major changes since previous revision)
Rev. 2.0, 2014-02	
	All chapters revised

Trademarks of Infineon Technologies AG

AURIX™, C166™, CanPAK™, CIPOS™, CIPURSE™, EconoPACK™, CoolMOS™, CoolSET™, CORECONTROL™, CROSSAVE™, DAVE™, DI-POL™, EasyPIM™, EconoBRIDGE™, EconoDUAL™, EconoPIM™, EconoPACK™, EiceDRIVER™, eupec™, FCOS™, HITFET™, HybridPACK™, I²RF™, ISOFACE™, IsoPACK™, MIPAQ™, ModSTACK™, my-d™, NovalithIC™, OptiMOS™, ORIGA™, POWERCODE™; PRIMARION™, PrimePACK™, PrimeSTACK™, PRO-SIL™, PROFET™, RASIC™, ReverSave™, SatRIC™, SIEGET™, SINDRION™, SIPMOS™, SmartLEWIS™, SOLID FLASH™, TEMPFET™, thinQ!™, TRENCHSTOP™, TriCore™.

Other Trademarks

Advance Design System™ (ADS) of Agilent Technologies, AMBA™, ARM™, MULTI-ICE™, KEIL™, PRIMECELL™, REALVIEW™, THUMB™, μVision™ of ARM Limited, UK. AUTOSAR™ is licensed by AUTOSAR development partnership. Bluetooth™ of Bluetooth SIG Inc. CAT-ig™ of DECT Forum. COLOSSUS™, FirstGPS™ of Trimble Navigation Ltd. EMV™ of EMVCo, LLC (Visa Holdings Inc.). EPCOS™ of Epcos AG. FLEXGO™ of Microsoft Corporation. FlexRay™ is licensed by FlexRay Consortium. HYPERTERMINAL™ of Hilgraeve Incorporated. IEC™ of Commission Electrotechnique Internationale. IrDA™ of Infrared Data Association Corporation. ISO™ of INTERNATIONAL ORGANIZATION FOR STANDARDIZATION. MATLAB™ of MathWorks, Inc. MAXIM™ of Maxim Integrated Products, Inc. MICROTEC™, NUCLEUS™ of Mentor Graphics Corporation. MIPI™ of MIPI Alliance, Inc. MIPS™ of MIPS Technologies, Inc., USA. muRata™ of MURATA MANUFACTURING CO., MICROWAVE OFFICE™ (MWO) of Applied Wave Research Inc., OmniVision™ of OmniVision Technologies, Inc. Openwave™ Openwave Systems Inc. RED HAT™ Red Hat, Inc. RFMD™ RF Micro Devices, Inc. SIRIUS™ of Sirius Satellite Radio Inc. SOLARIS™ of Sun Microsystems, Inc. SPANSION™ of Spansion LLC Ltd. Symbian™ of Symbian Software Limited. TAIYO YUDEN™ of Taiyo Yuden Co. TEAKLITE™ of CEVA, Inc. TEKTRONIX™ of Tektronix Inc. TOKO™ of TOKO KABUSHIKI KAISHA TA. UNIX™ of X/Open Company Limited. VERILOG™, PALLADIUM™ of Cadence Design Systems, Inc. VLYNQ™ of Texas Instruments Incorporated. VXWORKS™, WIND RIVER™ of WIND RIVER SYSTEMS, INC. ZETEX™ of Diodes Zetex Limited.

Last Trademarks Update 2011-11-11

Table of Contents

	Table of Contents	4
	List of Figures	6
	List of Tables	7
1	Product Description	8
1.1	Overview	8
1.2	Features	9
1.3	Application Example	9
2	Functional Description	10
2.1	Block Diagram	10
2.2	Functional Block Description	10
2.2.1	Internal Power Supply	10
2.2.2	Oscillator and PLL	10
2.2.3	SD-ADC	11
2.2.4	Digital Signal Processing Unit	11
2.2.5	Interfaces	11
2.2.6	Safety Features	11
2.3	Sensing Principle	12
2.4	Pin Configuration	14
2.5	Pin Description	14
3	Application Circuits	15
4	Specification	19
4.1	Absolute Maximum Ratings	19
4.2	Operating Range	19
4.3	Characteristics	21
4.3.1	Input/Output characteristics	21
4.3.2	ESD Protection	23
4.3.3	GMR Parameters	23
4.3.4	Angle Performance	24
4.3.5	Autocalibration	25
4.3.6	Signal Processing	26
4.3.7	Clock Supply (CLK Timing Definition)	28
4.4	Interfaces	29
4.4.1	Synchronous Serial Communication (SSC)	29
4.4.1.1	SSC Timing Definition	29
4.4.1.2	SSC Data Transfer	31
4.4.2	Pulse Width Modulation (PWM) Interface	34
4.4.3	Short PWM Code (SPC)	36
4.4.3.1	Unit Time Setup	37
4.4.3.2	Master Trigger Pulse Requirements	38
4.4.3.3	Checksum Nibble Details	38
4.4.4	Hall Switch Mode (HSM)	39
4.4.5	Incremental Interface (IIF)	42
4.5	Test Mechanisms	43
4.5.1	ADC Test Vectors	43
4.6	Supply Monitoring	44
4.6.1	Internal Supply Voltage Comparators	45

Table of Contents

4.6.2	V _{DD} Overvoltage Detection	45
4.6.3	GND - Off Comparator	45
4.6.4	V _{DD} - Off Comparator	45
5	Pre-Configured Derivates	46
5.1	IIF-type: E1000	46
5.2	HSM-type: E3005	46
5.3	PWM-type: E5000	46
5.4	PWM-type: E5020	46
5.5	SPC-type: E9000	46
6	Package Information	47
6.1	Package Parameters	47
6.2	Package Outline	47
6.3	Footprint	48
6.4	Packing	49
6.5	Marking	49

List of Figures

Figure 1-1	PG-DSO-8 package	8
Figure 2-1	TLE5012B block diagram	10
Figure 2-2	Sensitive bridges of the GMR sensor (not to scale)	12
Figure 2-3	Ideal output of the GMR sensor bridges	13
Figure 2-4	Pin configuration (top view)	14
Figure 3-1	Application circuit for TLE5012B with IIF interface and SSC (using internal CLK)	15
Figure 3-2	Application circuit for TLE5012B with HS Mode and SSC (using internal CLK)	15
Figure 3-3	Application circuit for TLE5012B with only PWM interface (using internal CLK)	16
Figure 3-4	Application circuit for TLE5012B with only PWM interface (using internal CLK)	16
Figure 3-5	Application circuit for TLE5012B with only SPC interface (using internal CLK)	17
Figure 3-6	SSC configuration in sensor-slave mode with push-pull outputs (high-speed application)	17
Figure 3-7	SSC configuration in sensor-slave mode and open-drain (bus systems)	18
Figure 4-1	Allowed magnetic field range as function of junction temperature	20
Figure 4-2	Offset and amplitude definition	23
Figure 4-3	Additional angle error for temperature changes above 5 Kelvin within 1.5 revolutions	25
Figure 4-4	Signal path	26
Figure 4-5	Delay of sensor output	26
Figure 4-6	External CLK timing definition	28
Figure 4-7	SSC timing	29
Figure 4-8	SSC data transfer (data-read example)	31
Figure 4-9	SSC data transfer (data-write example)	31
Figure 4-10	SSC bit ordering (read example)	33
Figure 4-11	Update of update registers	33
Figure 4-12	Fast CRC polynomial division circuit	34
Figure 4-13	Typical example of a PWM signal	35
Figure 4-14	SPC frame example	36
Figure 4-15	SPC pause timing diagram	36
Figure 4-16	SPC Master pulse timing	38
Figure 4-17	Hall Switch Mode	39
Figure 4-18	HS hysteresis	42
Figure 4-19	Incremental interface with A/B mode	42
Figure 4-20	Incremental interface with Step/Direction mode	43
Figure 4-21	ADC test vectors	44
Figure 4-22	Overvoltage comparator	45
Figure 4-23	GND - off comparator	45
Figure 4-24	V_{DD} - off comparator	45
Figure 6-1	PG-DSO-8 package dimension	47
Figure 6-2	Position of sensing element	48
Figure 6-3	Footprint of PG-DSO-8	48
Figure 6-4	Tape and Reel	49

List of Tables

Table 1-1	Derivate Ordering codes	8
Table 2-1	Pin Description	14
Table 4-1	Absolute maximum ratings	19
Table 4-2	Operating range and parameters	19
Table 4-3	Input voltage and output currents	21
Table 4-4	Driver strength characteristic	21
Table 4-5	Electrical parameters for $4.5\text{ V} < V_{DD} < 5.5\text{ V}$	22
Table 4-6	Electrical parameters for $3.0\text{ V} < V_{DD} < 3.6\text{ V}$	22
Table 4-7	ESD protection	23
Table 4-8	Basic GMR parameters	23
Table 4-9	Angle performance	24
Table 4-10	Signal processing	27
Table 4-11	Internal clock timing specification	28
Table 4-12	External Clock Specification	28
Table 4-13	SSC push-pull timing specification	29
Table 4-14	SSC open-drain timing specification	30
Table 4-15	Structure of the Command Word	31
Table 4-16	Structure of the Safety Word	32
Table 4-17	Bit Types	32
Table 4-18	PWM interface	35
Table 4-19	Frame configuration	37
Table 4-20	Structure of status nibble	37
Table 4-21	Predivider setting	37
Table 4-22	Master pulse parameters	38
Table 4-23	Hall Switch Mode	39
Table 4-24	Incremental Interface	43
Table 4-25	ADC test vectors	43
Table 4-26	Test comparator threshold voltages	44
Table 6-1	Package Parameters	47
Table 6-2	Sensor IC placement tolerances in package	48

1 Product Description

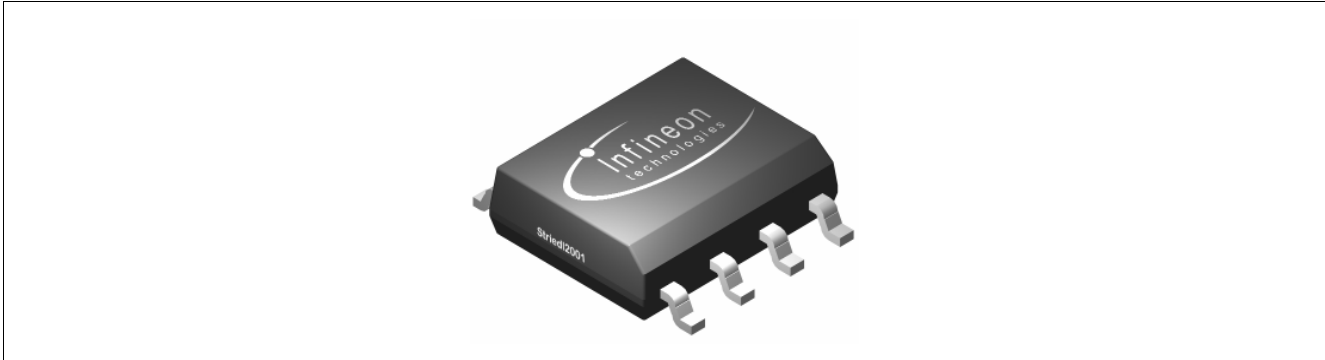

Figure 1-1 PG-DSO-8 package

1.1 Overview

The TLE5012B is a 360° angle sensor that detects the orientation of a magnetic field. This is achieved by measuring sine and cosine angle components with monolithic integrated Giant Magneto Resistance (iGMR) elements. These raw signals (sine and cosine) are digitally processed internally to calculate the angle orientation of the magnetic field (magnet).

The TLE5012B is a pre-calibrated sensor. The calibration parameters are stored in laser fuses. At start-up the values of the fuses are written into flip-flops, where these values can be changed by the application-specific parameters. Further precision of the angle measurement over a wide temperature range and a long lifetime can be improved by enabling an optional internal autocalibration algorithm.

Data communications are accomplished with a bi-directional Synchronous Serial Communication (SSC) that is SPI-compatible. The sensor configuration is stored in registers, which are accessible by the SSC interface.

Additionally four other interfaces are available with the TLE5012B: Pulse-Width-Modulation (PWM) Protocol, Short-PWM-Code (SPC) Protocol, Hall Switch Mode (HSM) and Incremental Interface (IIF). These interfaces can be used in parallel with SSC or alone. Pre-configured sensor derivatives with different interface settings are available (see [Table 1-1](#) and [Chapter 5](#))

Online diagnostic functions are provided to ensure reliable operation.

Table 1-1 Derivate Ordering codes

Product Type	Marking	Ordering Code	Package
TLE5012B E1000	012B1000	SP001166960	PG-DSO-8
TLE5012B E3005	012B3005	SP001166964	PG-DSO-8
TLE5012B E5000	012B5000	SP001166968	PG-DSO-8
TLE5012B E5020	012B5020	SP001166972	PG-DSO-8
TLE5012B E9000	012B9000	SP001166998	PG-DSO-8

Note: See [Chapter 5](#) for description of derivatives.

1.2 Features

- **Giant Magneto Resistance (GMR)**-based principle
- Integrated magnetic field sensing for angle measurement
- 360° angle measurement with revolution counter and angle speed measurement
- Two separate highly accurate single bit SD-ADC
- 15 bit representation of absolute angle value on the output (resolution of 0.01°)
- 16 bit representation of sine / cosine values on the interface
- Max. 1.0° angle error over lifetime and temperature-range with activated auto-calibration
- Bi-directional SSC Interface up to 8Mbit/s
- Supports Safety Integrity Level (SIL) with diagnostic functions and status information
- Interfaces: SSC, PWM, Incremental Interface (IIF), Hall Switch Mode (HSM), Short PWM Code (SPC, based on SENT protocol defined in SAE J2716)
- Output pins can be configured (programmed or pre-configured) as push-pull or open-drain
- Bus mode operation of multiple sensors on one line is possible with SSC or SPC interface in open-drain configuration
- 0.25 μm CMOS technology
- Automotive qualified: -40°C to 150°C (junction temperature)
- ESD > 4kV (HBM)
- RoHS compliant (Pb-free package)
- Halogen-free

1.3 Application Example

The TLE5012B GMR-based angle sensor is designed for angular position sensing in automotive applications such as:

- Electrical commutated motor (e.g. used in Electric Power Steering (EPS))
- Rotary switches
- Steering angle measurements
- General angular sensing

2 Functional Description

2.1 Block Diagram

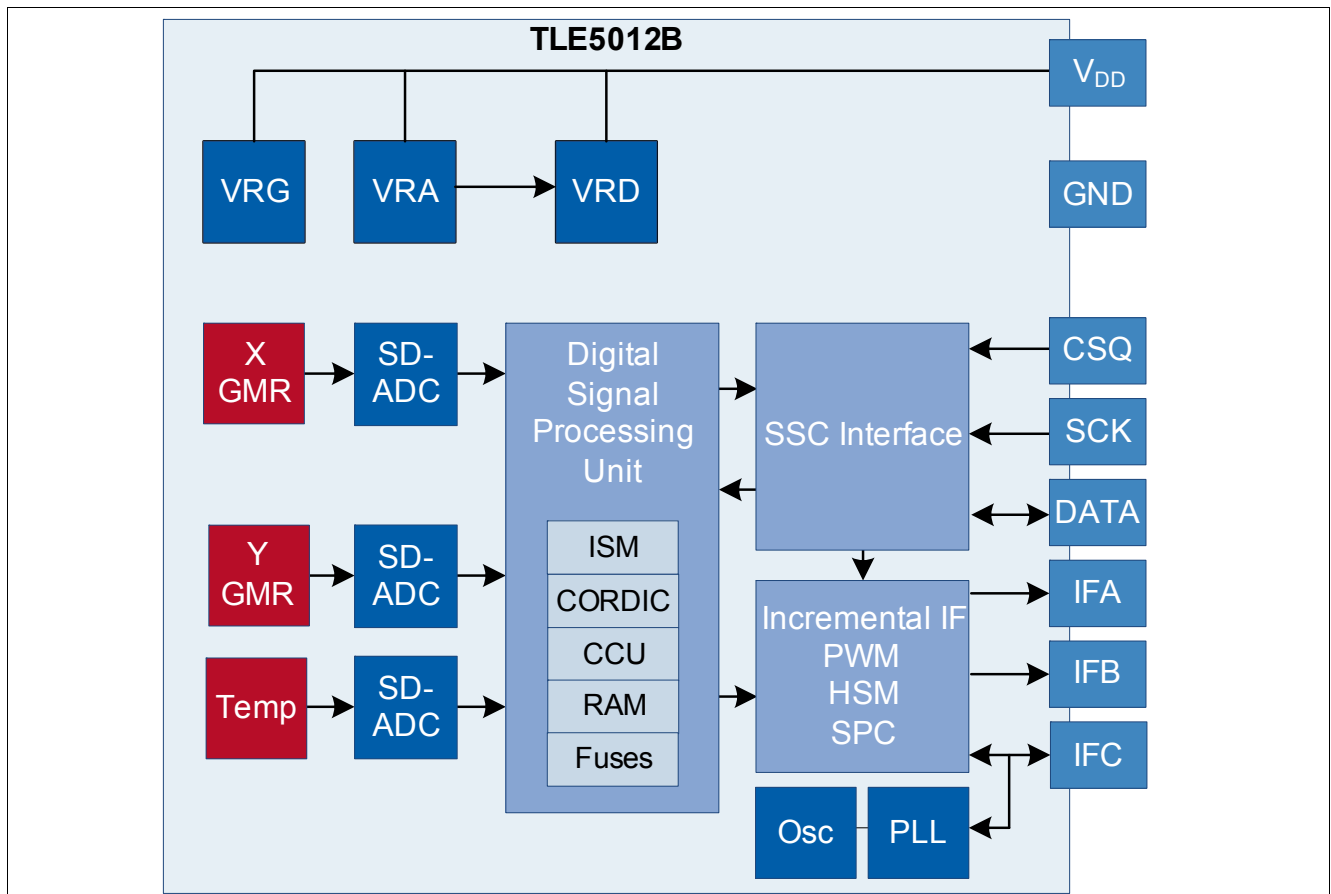

Figure 2-1 TLE5012B block diagram

2.2 Functional Block Description

2.2.1 Internal Power Supply

The internal stages of the TLE5012B are supplied with several voltage regulators:

- GMR Voltage Regulator, VRG
- Analog Voltage Regulator, VRA
- Digital Voltage Regulator, VRD (derived from VRA)

These regulators are directly connected to the supply voltage V_{DD}.

2.2.2 Oscillator and PLL

The digital clock of the TLE5012B is given by the Phase-Locked Loop (PLL), which is by default fed by an internal oscillator. In order to synchronize the TLE5012B with other ICs in a system, the TLE5012B can be configured via

SSC interface to use an external clock signal supplied on the IFC pin as source for the PLL, instead of the internal clock. External clock mode is only available in PWM or SPC interface configuration.

2.2.3 SD-ADC

The **Sigma-Delta Analog-Digital-Converters (SD-ADC)** transform the analog GMR voltages and temperature voltage into the digital domain.

2.2.4 Digital Signal Processing Unit

The Digital Signal Processing Unit (DSPU) contains the:

- **I**ntelligent **S**tate **M**achine (**ISM**), which does error compensation of offset, offset temperature drift, amplitude synchronicity and orthogonality of the raw signals from the GMR bridges, and performs additional features such as auto-calibration, prediction and angle speed calculation
- **C**Oordinate **R**otation **D**igital **C**omputer (**CORDIC**), which contains the trigonometric function for angle calculation
- **C**apture **C**ompare **U**nit (**CCU**), which is used to generate the PWM and SPC signals
- **R**andom **A**ccess **M**emory (**RAM**), which contains the configuration registers
- Laser Fuses, which contain the calibration parameters for the error-compensation and the IC default configuration, which is loaded into the RAM at startup

2.2.5 Interfaces

Bi-directional communication with the TLE5012B is enabled by a three-wire SSC interface. In parallel to the SSC interface, one secondary interface can be selected, which is available on the IFA, IFB, IFC pins:

- PWM
- Incremental Interface
- Hall Switch Mode
- Short PWM Code

By using pre-configured derivatives (see [Chapter 5](#)), the TLE5012B can also be operated with the secondary interface only, without SSC communication.

2.2.6 Safety Features

The TLE5012B offers a multiplicity of safety features to support the Safety Integrity Level (SIL) and it is a PRO-SIL™ product.

Safety features are:

- Test vectors switchable to ADC input (activated via SSC interface)
- Inversion or combination of filter input streams (activated via SSC interface)
- Data transmission check via 8-bit **C**yclic **R**edundancy **C**heck (**CRC**) for SSC communication and 4-bit CRC nibble for SPC interface
- Built-in Self-test (BIST) routines for ISM, CORDIC, CCU, ADCs run at startup
- Two independent active interfaces possible
- Overvoltage and undervoltage detection

Disclaimer

PRO-SIL™ is a Registered Trademark of Infineon Technologies AG.

The PRO-SIL™ Trademark designates Infineon products which contain SIL Supporting Features.

SIL Supporting Features are intended to support the overall System Design to reach the desired SIL (according to IEC61508) or A-SIL (according to ISO26262) level for the Safety System with high efficiency.

SIL respectively A-SIL certification for such a System has to be reached on system level by the System Responsible at an accredited Certification Authority.

SIL stands for Safety Integrity Level (according to IEC 61508)

A-SIL stands for Automotive-Safety Integrity Level (according to ISO 26262)

2.3 Sensing Principle

The Giant Magneto Resistance (GMR) sensor is implemented using vertical integration. This means that the GMR-sensitive areas are integrated above the logic part of the TLE5012B device. These GMR elements change their resistance depending on the direction of the magnetic field.

Four individual GMR elements are connected to one Wheatstone sensor bridge. These GMR elements sense one of two components of the applied magnetic field:

- X component, V_x (cosine) or the
- Y component, V_y (sine)

With this full-bridge structure the maximum GMR signal is available and temperature effects cancel out each other.

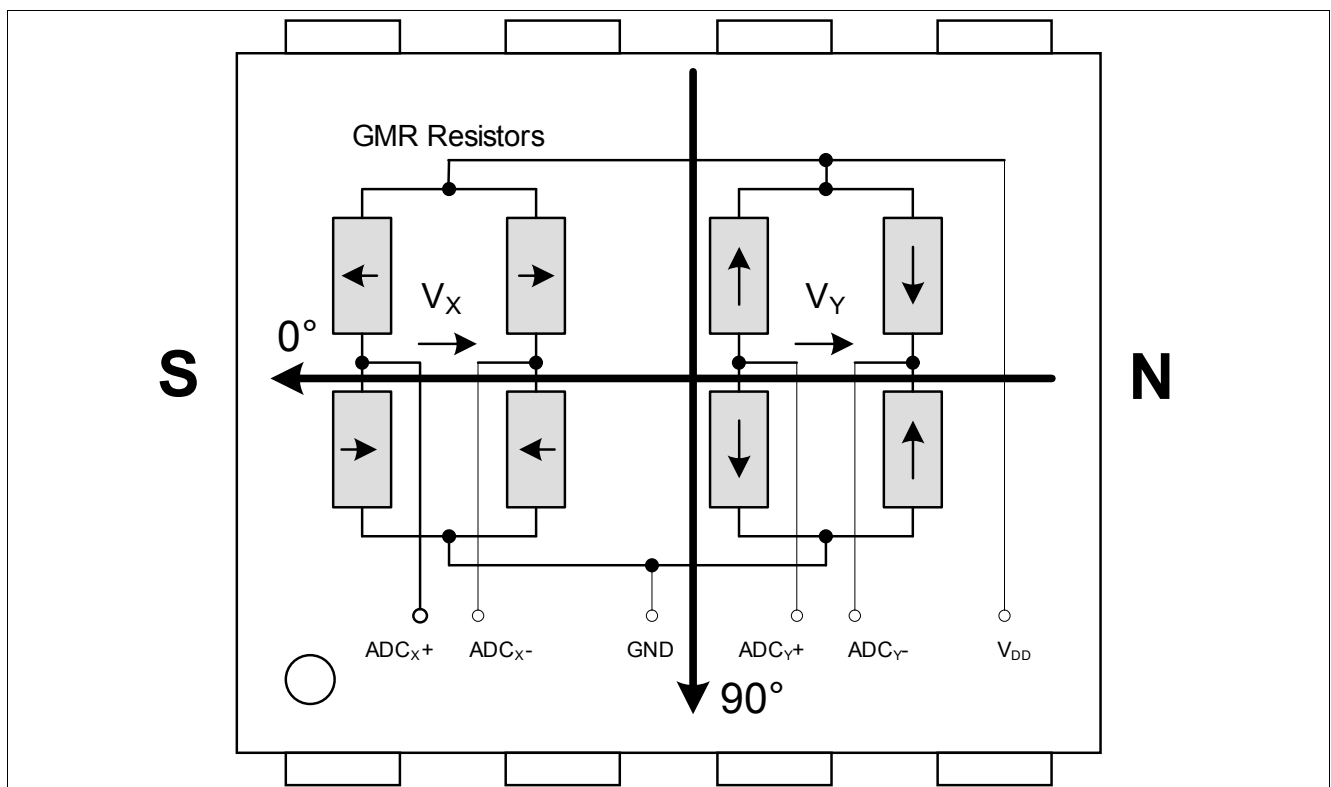

Figure 2-2 Sensitive bridges of the GMR sensor (not to scale)

Attention: Due to the rotational placement inaccuracy of the sensor IC in the package, the sensors 0° position may deviate by up to 3° from the package edge direction indicated in Figure 2-2.

In Figure 2-2, the arrows in the resistors represent the magnetic direction which is fixed in the reference layer. If the external magnetic field is parallel to the direction of the Reference Layer, the resistance is minimal. If they are anti-parallel, resistance is maximal.

The output signal of each bridge is only unambiguous over 180° between two maxima. Therefore two bridges are oriented orthogonally to each other to measure 360° .

With the trigonometric function ARCTAN2 , the true 360° angle value is calculated out of the raw X and Y signals from the sensor bridges.

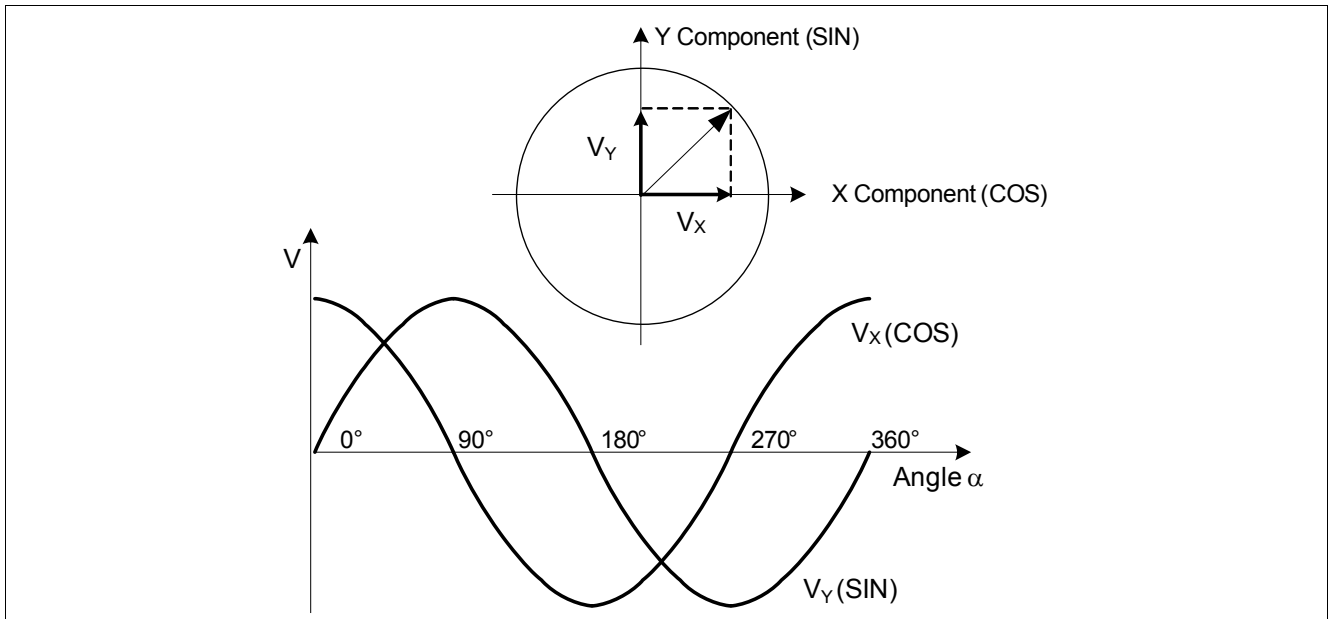

Figure 2-3 Ideal output of the GMR sensor bridges

2.4 Pin Configuration

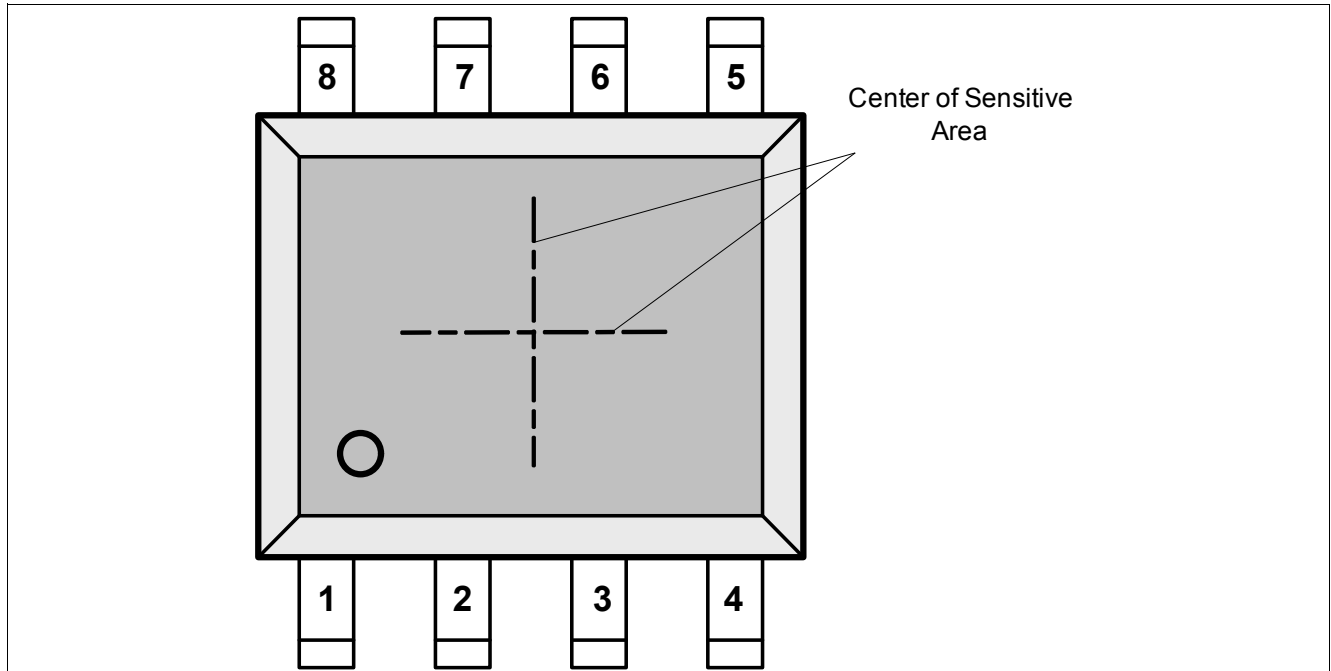

Figure 2-4 Pin configuration (top view)

2.5 Pin Description

Table 2-1 Pin Description

Pin No.	Symbol	In/Out	Function
1	IFC (CLK / IIF_IDX / HS3)	I/O	Interface C: External Clock ¹⁾ / IIF Index / Hall Switch Signal 3
2	SCK	I	SSC Clock
3	CSQ	I	SSC Chip Select
4	DATA	I/O	SSC Data
5	IFA (IIF_A / HS1 / PWM / SPC)	I/O	Interface A: IIF Phase A / Hall Switch Signal 1 / PWM / SPC output (input for SPC trigger only)
6	V _{DD}	-	Supply Voltage
7	GND	-	Ground
8	IFB (IIF_B / HS2)	O	Interface B: IIF Phase B / Hall Switch Signal 2

1) External clock feature is not available in IIF or HSM interface mode

3 Application Circuits

The application circuits in this chapter show the various communication possibilities of the TLE5012B. The pin output mode configuration is device-specific and it can be either push-pull or open-drain. The bit IFAB_OD (register IFAB, 0D_H) indicates the output mode for the IFA, IFB and IFC pins. The SSC pins are by default push-pull (bit SSC_OD, register MOD_3, 09_H).

Figure 3-1 shows a basic block diagram of a TLE5012B with Incremental Interface and SSC configuration. The derivate TLE5012B - E1000 is by default configured with push-pull IFA (IIF_A), IFB (IIF_B) and IFC (IIF_IDX) pins.

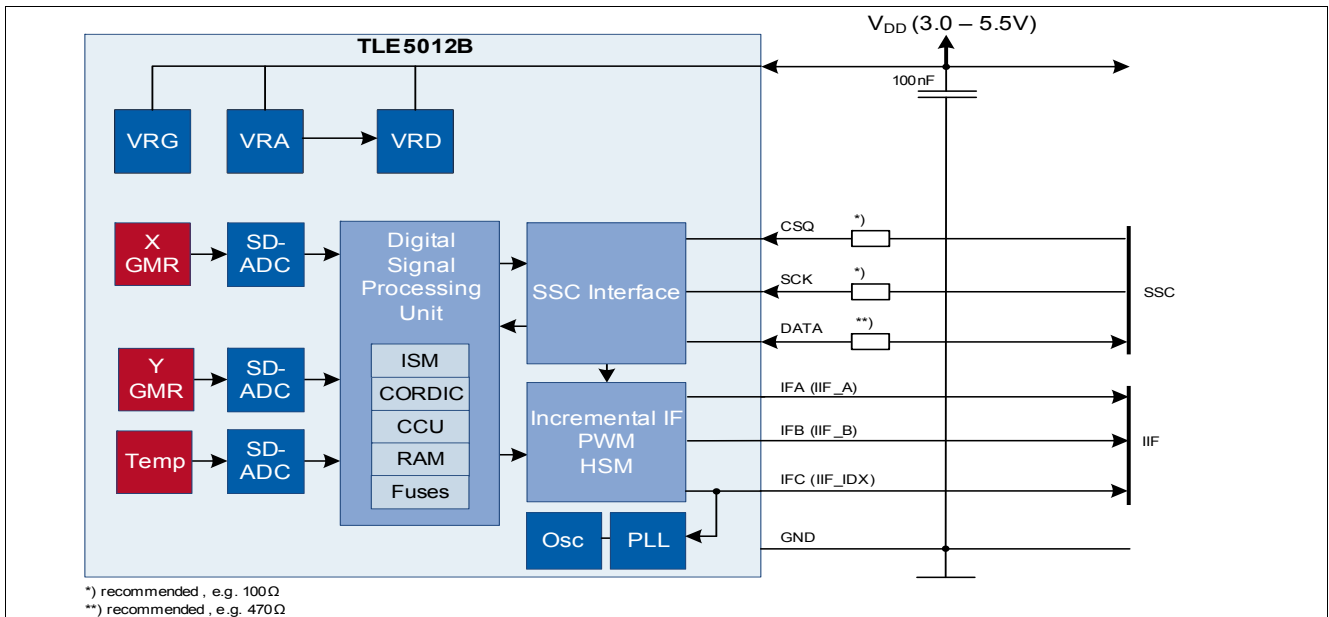

Figure 3-1 Application circuit for TLE5012B with IIF interface and SSC (using internal CLK)

In case that the IFA, IFB and IFC pins are configured via the SSC interface as open-drain pins, three resistors (one for each line) between output line and V_{DD} would be recommended (e.g. 2.2kΩ).

Figure 3-2 shows a basic block diagram of the TLE5012B with HS Mode and SSC configuration. The derivate TLE5012B - E3005 is by default configured with push-pull IFA (HS1), IFB (HS2) and IFC (HS3) pins.

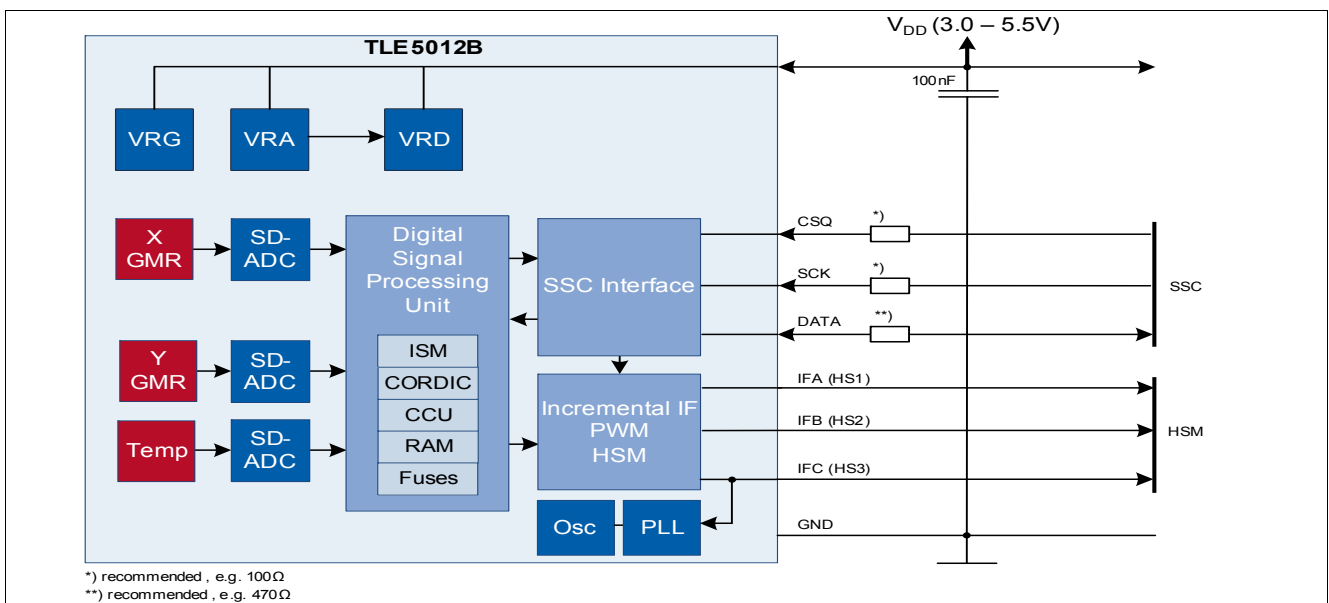

Figure 3-2 Application circuit for TLE5012B with HS Mode and SSC (using internal CLK)

In case that the IFA, IFB and IFC pins are configured via the SSC interface as open drain pins, three resistors (one for each line) between the output line and V_{DD} would be recommended (e.g. 2.2k Ω).

The TLE5012B can be configured with PWM only (Figure 3-3). The derivate TLE5012B - E5000 is by default configured with push-pull IFA (PWM) pin. Therefore the following configuration is recommended:

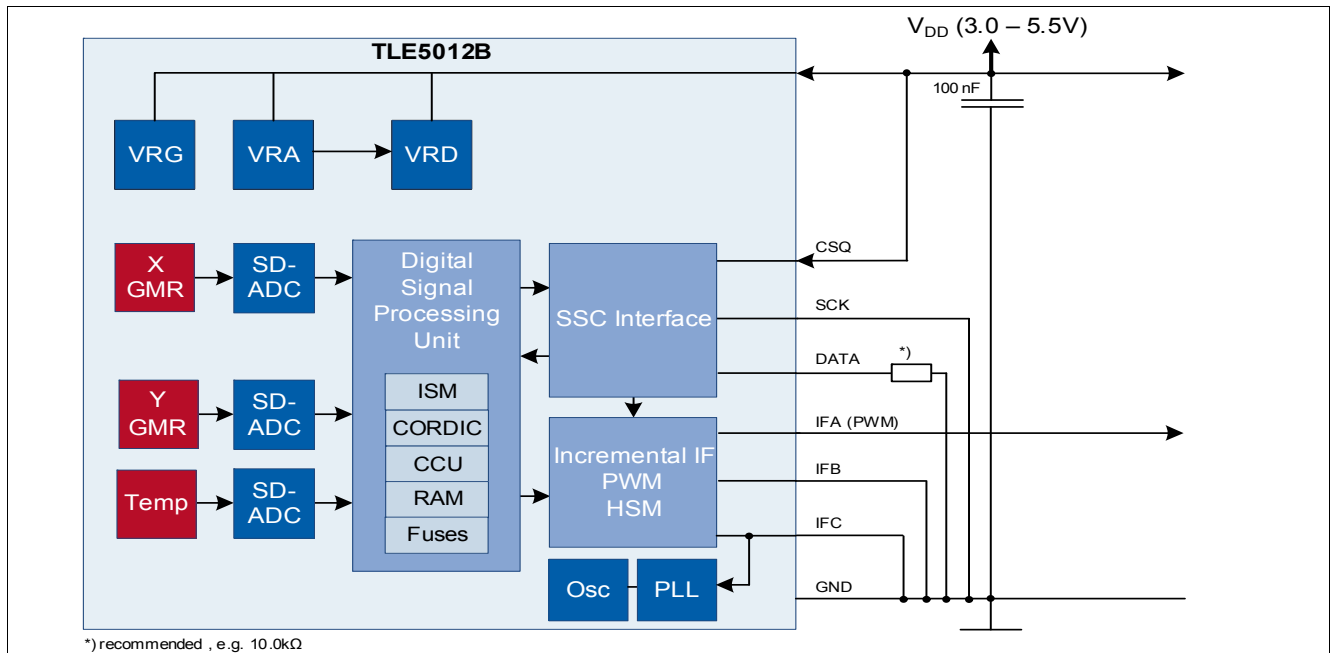

Figure 3-3 Application circuit for TLE5012B with only PWM interface (using internal CLK)

The TLE5012B - E5020 is also a PWM derivate but with open drain IFA (PWM) pin. A pull-up resistor (e.g. 2.2k Ω) should then be added between the IFA line and V_{DD} , as shown in Figure 3-4.

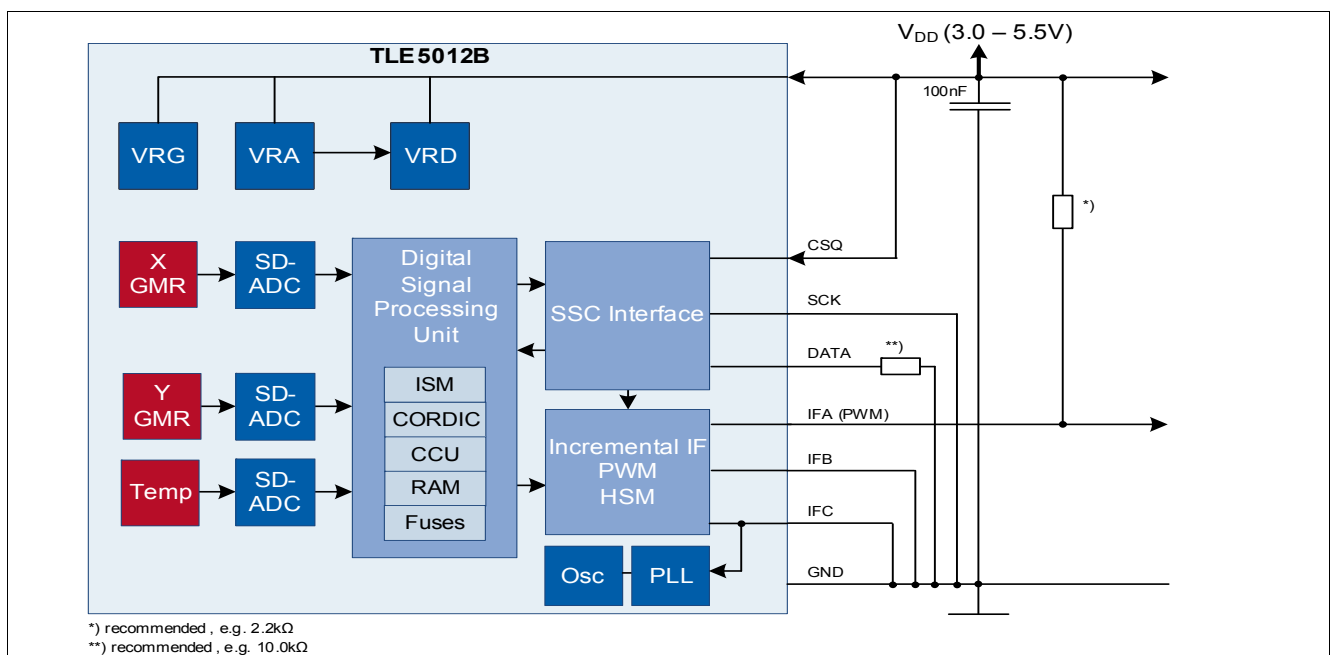

Figure 3-4 Application circuit for TLE5012B with only PWM interface (using internal CLK)

For safety reasons it is better that the non-used pins are connected to ground, rather than floating. A resistor between the DATA line pin and ground is recommended to avoid shortcuts if DATA generates any unexpected output. The CSQ line has to be connected to V_{DD} to avoid unintentional activation of the SSC interface.

The TLE5012B can be configured with SPC only (Figure 3-5). This is only possible with the TLE5012B - E9000 derivate, which is by default configured with an open-drain IFA (SPC) pin.

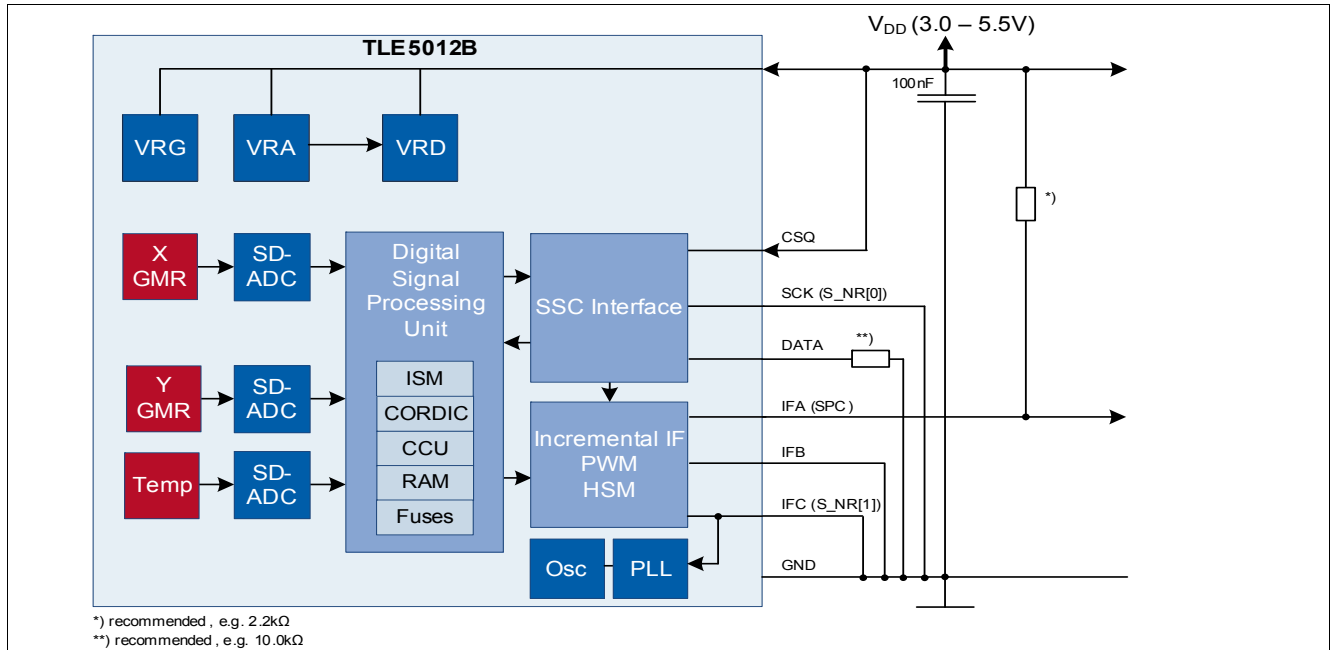

Figure 3-5 Application circuit for TLE5012B with only SPC interface (using internal CLK)

In Figure 3-5 the IFC (S_NR[1]) and SCK (S_NR[0]) pins are set to ground to generate the slave number (S_NR) 0_D (or 00_B). For safety reasons it is better that the non-used pins are connected to ground, rather than floating. A resistor between the DATA line pin and ground is recommended to avoid shortcuts if DATA generates any unexpected output. The CSQ line has to be connected to V_{DD} to avoid unintentional activation of the SSC interface.

Synchronous Serial Communication (SSC) configuration

In Figure 3-1 and Figure 3-2 the SSC interface has the default push-pull configuration (see details in Figure 3-6). Series resistors on the DATA, SCK (serial clock signal) and CSQ (chip select) lines are recommended to limit the current in the erroneous case that either the sensor pushes high and the microcontroller pulls low at the same time or vice versa. The resistors in the SCK and CSQ lines are only necessary in case of disturbances or noise.

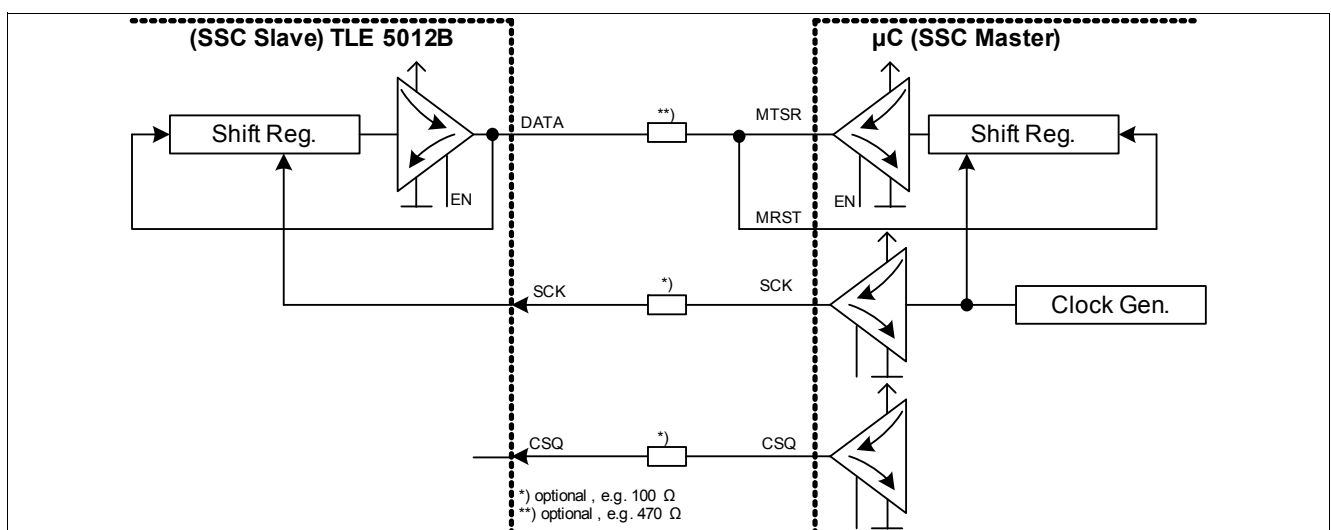

Figure 3-6 SSC configuration in sensor-slave mode with push-pull outputs (high-speed application)

It is also possible to use an open-drain setup for the DATA, SCK and CSQ lines. This setup is designed to communicate with a microcontroller in a bus system, together with other SSC slaves (e.g. two TLE5012B devices for redundancy reasons). This mode can be activated using the bit SSC_OD.

The open-drain configuration can be seen in [Figure 3-7](#). Series resistors on the DATA, SCK, and CSQ lines are recommended to limit the current in case either the microcontroller or the sensor are accidentally switched to push-pull. A pull-up resistor of typ. 1 kΩ is required on the DATA line.

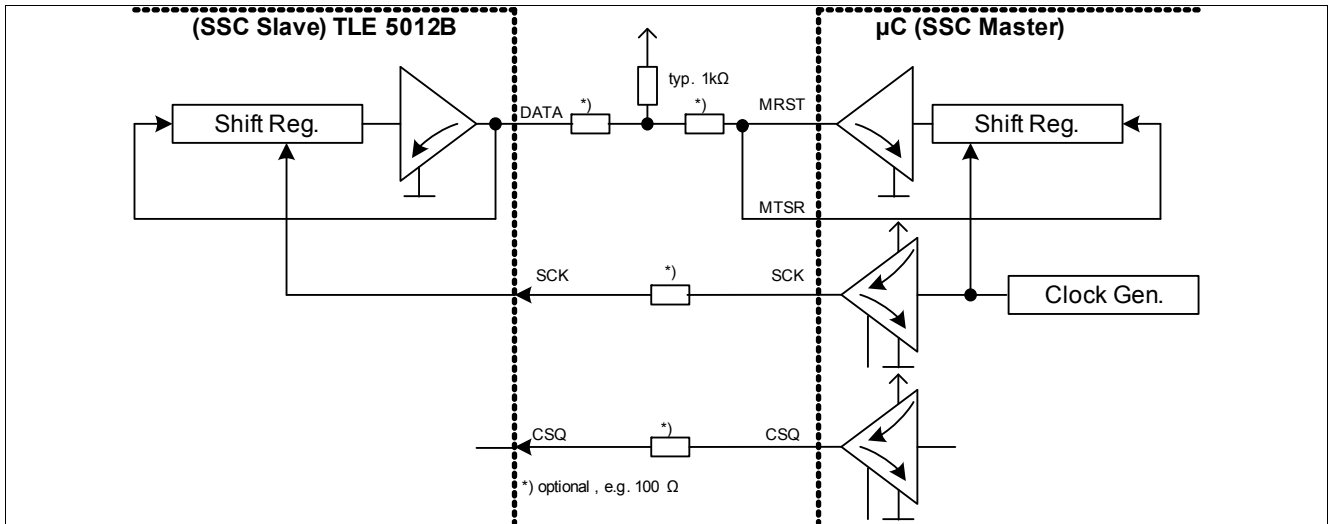

Figure 3-7 SSC configuration in sensor-slave mode and open-drain (bus systems)

4 Specification

4.1 Absolute Maximum Ratings

Table 4-1 Absolute maximum ratings

Parameter	Symbol	Values			Unit	Note / Test Condition
		Min.	Typ.	Max.		
Voltage on V_{DD} pin with respect to ground (V_{SS})	V_{DD}	-0.5		6.5	V	Max 40 h/Lifetime
Voltage on any pin with respect to ground (V_{SS})	V_{IN}	-0.5		6.5	V	
				$V_{DD} + 0.5$	V	
Junction temperature	T_J	-40		150	°C	
				150	°C	
Magnetic field induction	B			200	mT	Max. 5 min @ $T_A = 25^\circ\text{C}$
				150	mT	Max. 5 h @ $T_A = 25^\circ\text{C}$
Storage temperature	T_{ST}	-40		150	°C	Without magnetic field

Attention: Stresses above the max. values listed here may cause permanent damage to the device. Exposure to absolute maximum rating conditions for extended periods may affect device reliability. Maximum ratings are absolute ratings; exceeding only one of these values may cause irreversible damage to the device.

4.2 Operating Range

The following operating conditions must not be exceeded in order to ensure correct operation of the TLE5012B. All parameters specified in the following sections refer to these operating conditions, unless otherwise noted. [Table 4-2](#) is valid for $-40^\circ\text{C} < T_J < 150^\circ\text{C}$ unless otherwise noted.

Table 4-2 Operating range and parameters

Parameter	Symbol	Values			Unit	Note / Test Condition
		Min.	Typ.	Max.		
Supply voltage	V_{DD}	3.0	5.0	5.5	V	1)
Supply current	I_{DD}		14	16	mA	
Magnetic induction at $T_J = 25^\circ\text{C}^{2)3)}$	B_{XY}	30		50	mT	$-40^\circ\text{C} < T_J < 150^\circ\text{C}$
		30		60	mT	$-40^\circ\text{C} < T_J < 100^\circ\text{C}$
		30		70	mT	$-40^\circ\text{C} < T_J < 85^\circ\text{C}$
Extended magnetic induction range at $T_J = 25^\circ\text{C}^{2)3)}$	B_{XY}	25		30	mT	Additional angle error of 0.1°
Angle range	Ang	0		360	°	
POR level	V_{POR}	2.0		2.9	V	Power-on reset
POR hysteresis	V_{PORhy}		30		mV	

Table 4-2 Operating range (cont'd) and parameters

Parameter	Symbol	Values			Unit	Note / Test Condition
		Min.	Typ.	Max.		
Power-on time ⁴⁾	t_{Pon}		5	7	ms	$V_{DD} > V_{DDmin}$
Fast Reset time ⁵⁾	t_{Rfast}			0.5	ms	Fast reset is triggered by disabling startup BIST (S_BIST = 0), then enabling chip reset (AS_RST = 1)

- 1) Directly blocked with 100-nF ceramic capacitor
- 2) Values refer to a homogeneous magnetic field (B_{xy}) without vertical magnetic induction ($B_z = 0mT$).
- 3) See [Figure 4-1](#)
- 4) During “Power-on time,” write access is not permitted (except for the switch to External Clock which requires a readout as a confirmation that external clock is selected)
- 5) Not subject to production test - verified by design/characterization

The field strength of a magnet can be selected within the colored area of [Figure 4-1](#). By limitation of the junction temperature, a higher magnetic field can be applied. In case of a maximum temperature $T_j=100^{\circ}C$, a magnet with up to 60mT at $T_j = 25^{\circ}C$ is allowed.

It is also possible to widen the magnetic field range for higher temperatures. In that case, additional angle errors have to be considered.

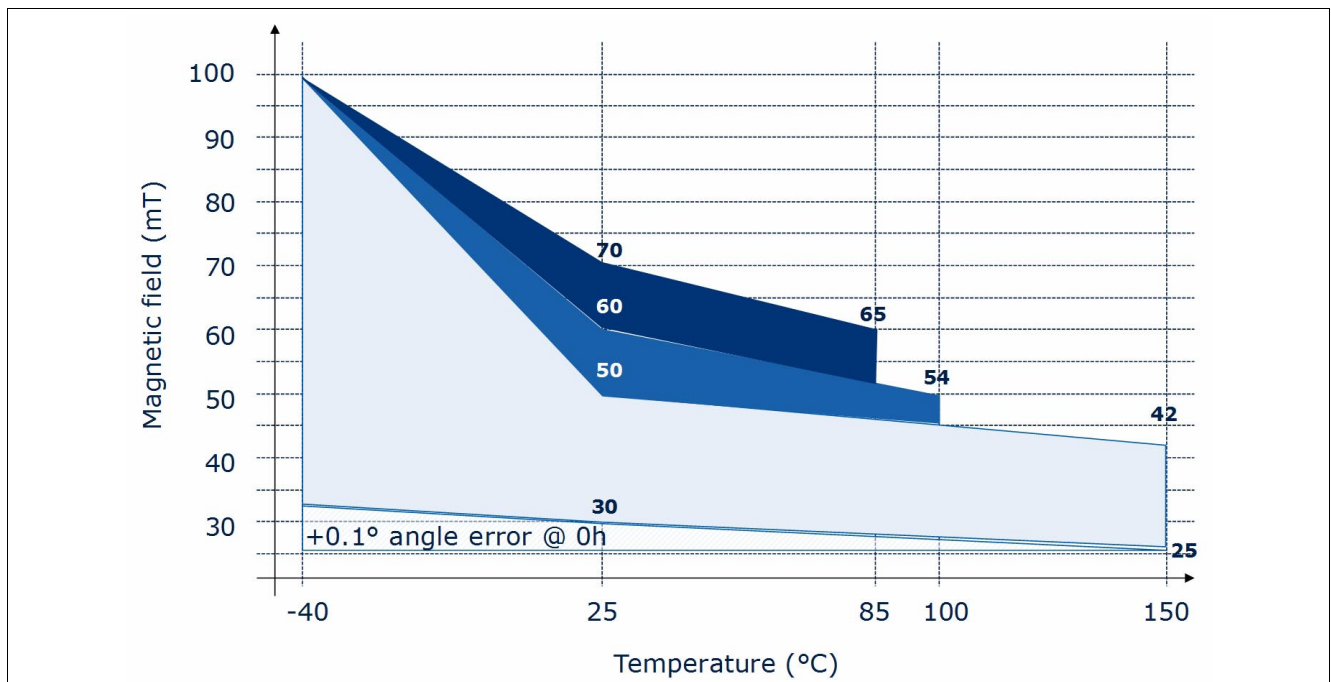

Figure 4-1 Allowed magnetic field range as function of junction temperature.

4.3 Characteristics

4.3.1 Input/Output characteristics

The indicated parameters apply to the full operating range, unless otherwise specified. The typical values correspond to a supply voltage $V_{DD} = 5.0\text{ V}$ and 25 °C , unless individually specified. All other values correspond to $-40\text{ °C} < T_J < 150\text{ °C}$.

Within the register MOD_3, the driver strength and the slope for push-pull communication can be varied depending on the sensor output. The driver strength is specified in [Table 4-3](#) and the slope fall and rise time in [Table 4-4](#).

Table 4-3 Input voltage and output currents

Parameter	Symbol	Values			Unit	Note / Test Condition
		Min.	Typ.	Max.		
Input voltage	V_{IN}	-0.3		5.5	V	
				$V_{DD} + 0.3$	V	
Output current (DATA-Pad)	I_Q			-25	mA	PAD_DRV = '0x', sink current ¹⁾²⁾
				-5	mA	PAD_DRV = '10', sink current ¹⁾²⁾
				-0.4	mA	PAD_DRV = '11', sink current ¹⁾²⁾
Output current (IFA / IFB / IFC - Pad)	I_Q			-15	mA	PAD_DRV = '0x', sink current ¹⁾²⁾
				-5	mA	PAD_DRV = '1x', sink current ¹⁾²⁾

1) Max. current to GND over open-drain output

2) At $V_{DD} = 5\text{ V}$

Table 4-4 Driver strength characteristic

Parameter	Symbol	Values			Unit	Note / Test Condition
		Min.	Typ.	Max.		
Output rise/fall time	t_{fall}, t_{rise}			8	ns	DATA, 50 pF, PAD_DRV='00' ¹⁾²⁾
				28	ns	DATA, 50 pF, PAD_DRV='01' ¹⁾²⁾
				45	ns	DATA, 50 pF, PAD_DRV='10' ¹⁾²⁾
				130	ns	DATA, 50 pF, PAD_DRV='11' ¹⁾²⁾
				15	ns	IFA/IFB, 20 pF, PAD_DRV='0x' ¹⁾²⁾
				30	ns	IFA/IFB, 20 pF, PAD_DRV='1x' ¹⁾²⁾

1) Valid for push-pull output

2) Not subject to production test - verified by design/characterization

Table 4-5 Electrical parameters for $4.5\text{ V} < V_{DD} < 5.5\text{ V}$

Parameter	Symbol	Values			Unit	Note / Test Condition
		Min.	Typ.	Max.		
Input signal low-level	V_{L5}			$0.3 V_{DD}$	V	
Input signal high level	V_{H5}	$0.7 V_{DD}$			V	
Output signal low-level	V_{OL5}			1	V	DATA; $I_Q = -25\text{ mA}$ (PAD_DRV='0x'), $I_Q = -5\text{ mA}$ (PAD_DRV='10'), $I_Q = -0.4\text{ mA}$ (PAD_DRV='11')
				1	V	IFA,B,C; $I_Q = -15\text{ mA}$ (PAD_DRV='0x'), $I_Q = -5\text{ mA}$ (PAD_DRV='1x')
Pull-up current ¹⁾	I_{PU}	-10		-225	μA	CSQ
		-10		-150	μA	DATA
Pull-down current ²⁾	I_{PD}	10		225	μA	SCK
		10		150	μA	IFA, IFB, IFC

1) Internal pull-ups on CSQ and DATA pin are always enabled.

2) Internal pull-downs on IFA, IFB and IFC are enabled during startup and in open-drain mode, internal pull-down on SCK is always enabled.

Table 4-6 Electrical parameters for $3.0\text{ V} < V_{DD} < 3.6\text{ V}$

Parameter	Symbol	Values			Unit	Note / Test Condition
		Min.	Typ.	Max.		
Input signal low-level	V_{L3}			$0.3 V_{DD}$	V	
Input signal high level	V_{H3}	$0.7 V_{DD}$			V	
Output signal low-level	V_{OL3}			0.9	V	DATA; $I_Q = -15\text{ mA}$ (PAD_DRV='0x'), $I_Q = -3\text{ mA}$ (PAD_DRV='10'), $I_Q = -0.24\text{ mA}$ (PAD_DRV='11')
				0.9	V	IFA,IFB; $I_Q = -10\text{ mA}$ (PAD_DRV='0x'), $I_Q = -3\text{ mA}$ (PAD_DRV='1x')
Pull-up current ¹⁾	I_{PU}	-3		-225	μA	CSQ
		-3		-150	μA	DATA
Pull-down current ²⁾	I_{PD}	3		225	μA	SCK
		3		150	μA	IFA, IFB, IFC

1) Internal pull-ups on CSQ and DATA pin are always enabled.

2) Internal pull-downs on IFA, IFB and IFC are enabled during startup and in open-drain mode, internal pull-down on SCK is always enabled.

4.3.2 ESD Protection

Table 4-7 ESD protection

Parameter	Symbol	Values		Unit	Notes
		Min.	Max.		
ESD voltage	V_{HBM}		± 4.0	kV	Human Body Model ¹⁾
	V_{SDM}		± 0.5	kV	Socketed Device Model ²⁾

- 1) Human Body Model (HBM) according to: AEC-Q100-002
- 2) Socketed Device Model (SDM) according to: ESDA/ANSI/ESD SP5.3.2-2008

4.3.3 GMR Parameters

All parameters apply over $B_{XY} = 30\text{mT}$ and $T_A = 25^\circ\text{C}$, unless otherwise specified.

Table 4-8 Basic GMR parameters

Parameter	Symbol	Values			Unit	Note / Test Condition
		Min.	Typ.	Max.		
X, Y output range	RG_{ADC}			± 23230	digits	Operating range ¹⁾
X, Y amplitude ²⁾	A_X, A_Y	6000	9500	15781	digits	At ambient temperature
		3922		20620	digits	Operating range
X, Y synchronicity ³⁾	k	87.5	100	112.49	%	
X, Y offset ⁴⁾	O_X, O_Y	-2048	0	+2047	digits	
X, Y orthogonality error	φ	-11.25	0	+11.24	$^\circ$	
X, Y amplitude without magnet	X_0, Y_0			+4096	digits	Operating range ¹⁾

- 1) Not subject to production test - verified by design/characterization
- 2) See [Figure 4-2](#)
- 3) $k = 100 \cdot (A_X / A_Y)$
- 4) $O_Y = (Y_{MAX} + Y_{MIN}) / 2$; $O_X = (X_{MAX} + X_{MIN}) / 2$

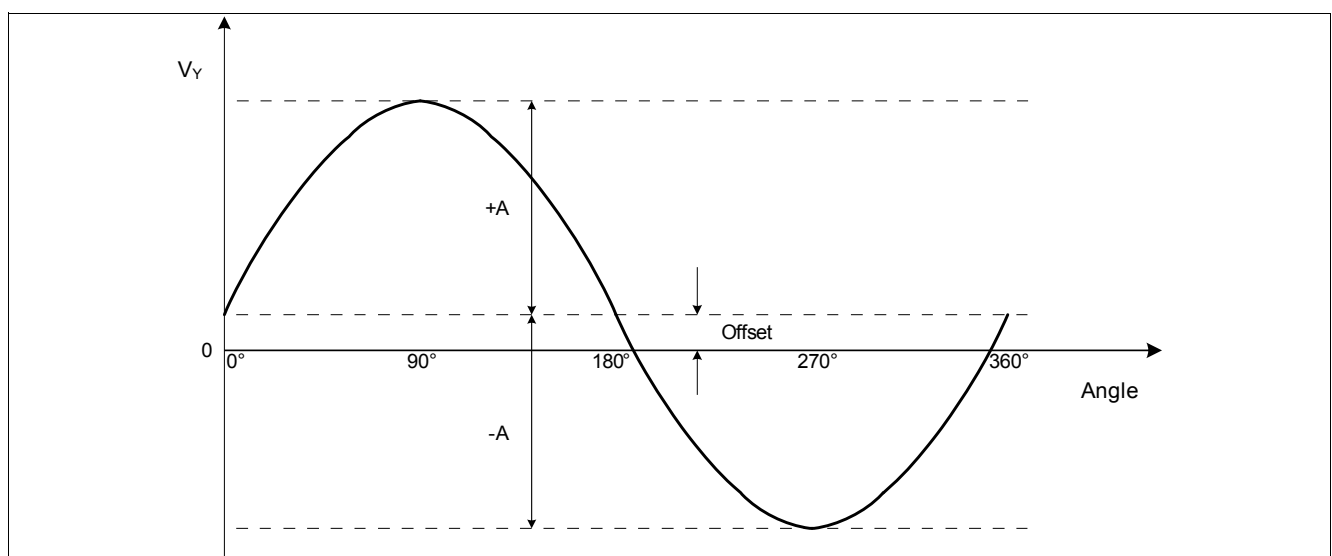

Figure 4-2 Offset and amplitude definition

4.3.4 Angle Performance

After internal calculation, the sensor has a remaining error, as shown in [Table 4-9](#). The error value refers to $B_z=0mT$ and the operating conditions given in [Table 4-2 “Operating range and parameters” on Page 19](#).

The overall angle error represents the relative angle error. This error describes the deviation from the reference line after zero-angle definition. It is valid for a static magnetic field.

If the magnetic field is rotating during the measurement, an additional propagation error is caused by the angle delay time (see [Table 4-10 “Signal processing” on Page 27](#)), which the sensor needs to calculate the angle from the raw sine and cosine values from the MR bridges. In fast-turning applications, prediction can be enabled to reduce this propagation error.

Table 4-9 Angle performance

Parameter	Symbol	Values			Unit	Note / Test Condition
		Min.	Typ.	Max.		
Overall angle error (with auto-calibration)	α_{Err}		0.6 ¹⁾	1.0	°	Including lifetime and temperature drift ²⁾³⁾⁴⁾ . Note: in case of temperature changes above 5 Kelvin within 1.5 revolutions refer to Figure 4-3 for additional angle error.
Overall angle error (without auto-calibration)	α_{Err}		0.6 ¹⁾	1.3	°	Including temperature drift ²⁾³⁾⁵⁾
				1.9	°	Including lifetime and temperature drift ²⁾³⁾⁴⁾

- 1) At 25°C, B = 30mT
- 2) Including hysteresis error, caused by revolution direction change
- 3) Relative error after zero angle definition
- 4) Not subject to production test - verified by design/characterization
- 5) 0h

If autocalibration (see [Chapter 4.3.5](#)) is enabled and the temperature changes by more than 5 Kelvin during 1.5 revolutions an additional error has to be added to the specified angle error in [Table 4-9](#). This error depends on the temperature change (Delta Temperature) as well as from the initial temperature (Tstart) as shown in [Figure 4-3](#). Once the temperature stabilizes and the application completes 1.5 revolutions, then the angle error is as specified in [Table 4-9](#).

For negative Delta Temperature changes (from higher to lower temperatures) the additional angle error will be smaller than the corresponding positive Delta Temperature changes (from lower to higher temperatures) shown in [Figure 4-3](#). The [Figure 4-3](#) applies to the worst case.

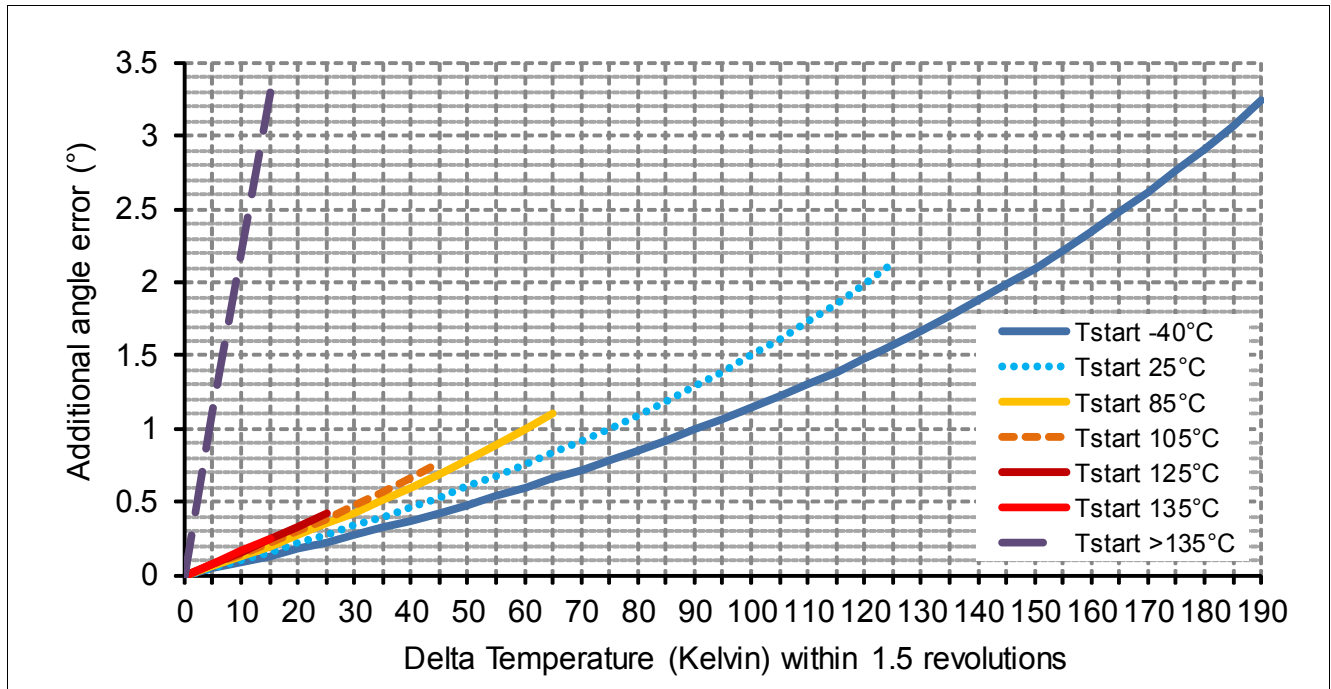

Figure 4-3 Additional angle error for temperature changes above 5 Kelvin within 1.5 revolutions

4.3.5 Autocalibration

The autocalibration enables online parameter calculation and therefore reduces the angle error due to temperature and lifetime drifts.

The TLE5012B is a pre-calibrated sensor, so autocalibration is only enabled in some devices by default. The update mode can be chosen with the AUTOCAL setting in the MOD_2 register. The TLE5012B needs 1.5 revolutions to generate new autocalibration parameters. These parameters are continuously updated. The parameters are updated in a smooth way (one Least-Significant Bit within the chosen range or time) to avoid an angle jump on the output.

AUTOCAL Modes:

- 00: No autocalibration
- 01: Autocalibration Mode 1. One LSB to final values within the update time t_{upd} (depending on FIR_MD setting).
- 10: Autocalibration Mode 2. Only one LSB update over one full parameter generation (1.5 revolutions). After update of one LSB, the autocalibration will calculate the parameters again.
- 11: Autocalibration Mode 3. One LSB to final values within an angle range of 11.25°

4.3.6 Signal Processing

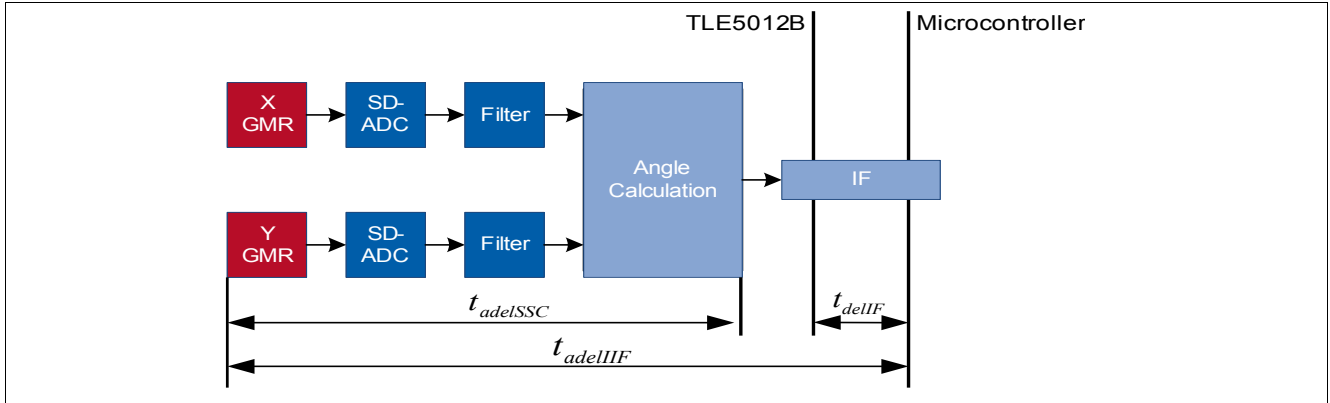

Figure 4-4 Signal path

The signal path of the TLE5012B is depicted in [Figure 4-4](#). It consists of the GMR-bridge, ADC, filter and angle calculation. The delay time between a physical change in the GMR elements and a signal on the output depends on the filter and interface configurations. In fast turning applications, this delay causes an additional rotation speed dependent angle error.

The TLE5012B has an optional prediction feature, which serves to reduce the speed dependent angle error in applications where the rotation speed does not change abruptly. Prediction uses the difference between current and last two angle values to approximate the angle value which will be present after the delay time (see [Figure 4-5](#)). The output value is calculated by adding this difference to the measured value, according to [Equation \(4.1\)](#).

$$\alpha(t+1) = \alpha(t) + \alpha(t-1) - \alpha(t-2) \tag{4.1}$$

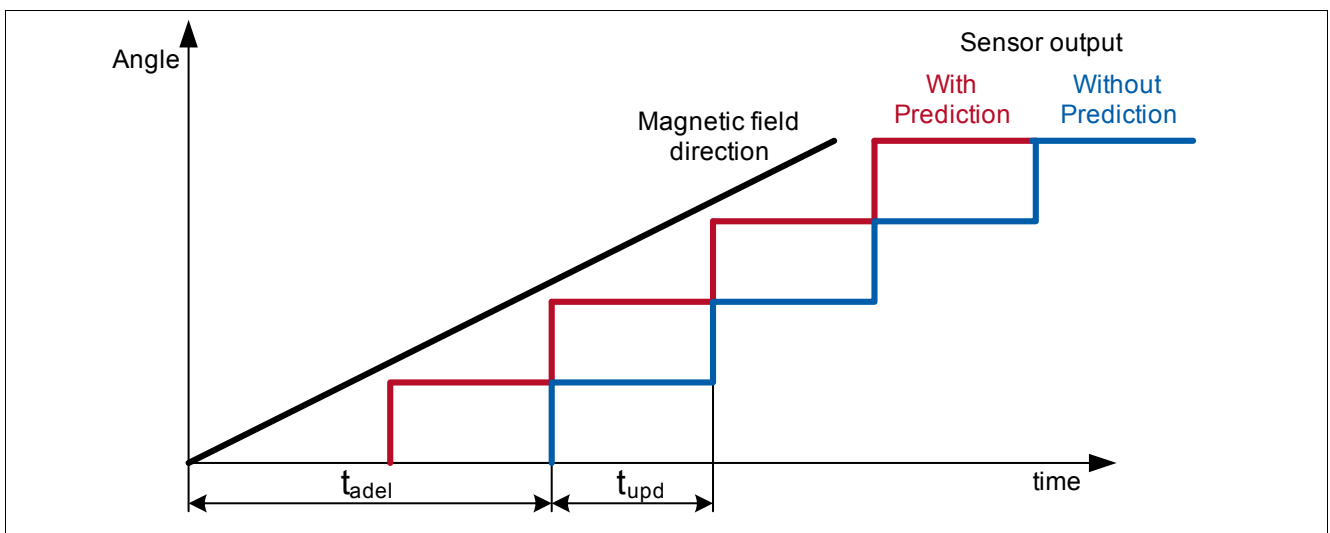

Figure 4-5 Delay of sensor output

Table 4-10 Signal processing

Parameter	Symbol	Values			Unit	Note / Test Condition
		Min.	Typ.	Max.		
Filter update period	t_{upd}		42.7		μs	FIR_MD = 1 (default) ¹⁾
			85.3		μs	FIR_MD = 2 ¹⁾
			170.6		μs	FIR_MD = 3 ¹⁾
Angle delay time without prediction ²⁾	$t_{adelSSC}$		85	95	μs	FIR_MD = 1 ¹⁾
			150	165	μs	FIR_MD = 2 ¹⁾
			275	300	μs	FIR_MD = 3 ¹⁾
	$t_{adelIFF}$		120	135	μs	FIR_MD = 1 ¹⁾
			180	200	μs	FIR_MD = 2 ¹⁾
			305	330	μs	FIR_MD = 3 ¹⁾
Angle delay time with prediction ²⁾	$t_{adelSSC}$		45	50	μs	FIR_MD = 1; PREDICT = 1 ¹⁾
			65	70	μs	FIR_MD = 2; PREDICT = 1 ¹⁾
			105	115	μs	FIR_MD = 3; PREDICT = 1 ¹⁾
	$t_{adelIFF}$		75	90	μs	FIR_MD = 1; PREDICT = 1 ¹⁾
			95	110	μs	FIR_MD = 2; PREDICT = 1 ¹⁾
			135	150	μs	FIR_MD = 3; PREDICT = 1 ¹⁾
Angle noise (RMS)	N_{Angle}		0.08		$^{\circ}$	FIR_MD = 1 ¹⁾
			0.05		$^{\circ}$	FIR_MD = 2 ¹⁾ (default)
			0.04		$^{\circ}$	FIR_MD = 3 ¹⁾

1) Not subject to production test - verified by design/characterization

2) Valid at constant rotation speed

All delay times specified in [Table 4-10](#) are valid for an ideal internal oscillator frequency of 24 MHz. For the exact timing, the variation of the internal oscillator frequency has to be taken into account (see [Chapter 4.3.7](#))

4.3.7 Clock Supply (CLK Timing Definition)

The internal clock supply of the TLE5012B is subject to production-specific variations, which have to be considered for all timing specifications.

Table 4-11 Internal clock timing specification

Parameter	Symbol	Values			Unit	Note / Test Condition
		Min.	Typ.	Max.		
Digital clock	f_{DIG}	22.8	24	25.8	MHz	
Internal oscillator frequency	f_{CLK}	3.8	4.0	4.3	MHz	

In order to fix the IC timing and synchronize the TLE5012B with other ICs in a system, it can be switched to operate with an external clock signal supplied to the IFC pin. The clock input signal must fulfill certain requirements:

- The high or low pulse width must not exceed the specified values, because the PLL needs a minimum pulse width and must be spike-filtered.
- The duty cycle factor should typically be 50%, but it can vary between 30% and 70%.
- The PLL is triggered at the positive edge of the clock. If more than 2 edges are missing, a chip reset is generated automatically and the sensor restarts with the internal clock. This is indicated by the S_RST, and CLK_SEL bits, and additionally by the Safety Word (see [Chapter 4.4.1.2](#)).

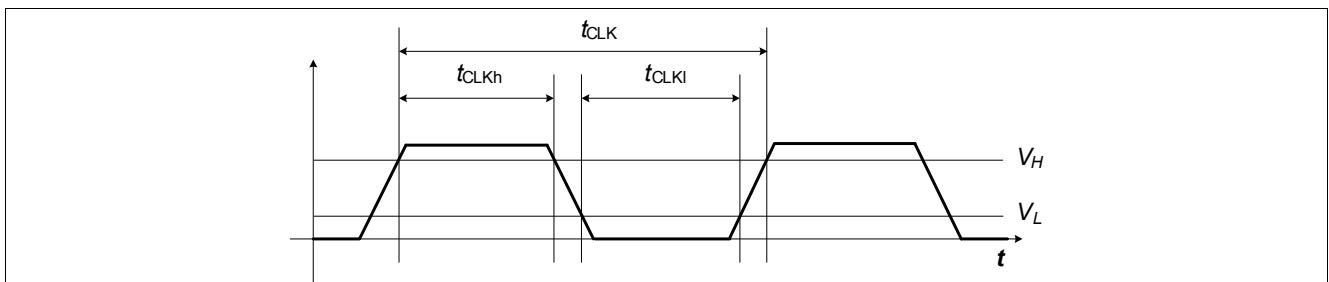

Figure 4-6 External CLK timing definition

Table 4-12 External Clock Specification

Parameter	Symbol	Values			Unit	Note / Test Condition
		Min.	Typ.	Max.		
Input frequency	f_{CLK}	3.8	4.0	4.3	MHz	
CLK duty cycle ¹⁾²⁾	CLK _{DUTY}	30	50	70	%	
CLK rise time	t_{CLKr}			30	ns	From V_L to V_H
CLK fall time	t_{CLKf}			30	ns	From V_H to V_L

1) Minimum duty cycle factor: $t_{CLKh(min)} / t_{CLK}$ with $t_{CLK} = 1 / f_{CLK}$

2) Maximum duty cycle factor: $t_{CLKh(max)} / t_{CLK}$ with $t_{CLK} = 1 / f_{CLK}$

4.4 Interfaces

4.4.1 Synchronous Serial Communication (SSC)

The 3-pin SSC interface consists of a bi-directional push-pull (tri-state on receive) or open-drain data pin (configurable with SSC_OD bit) and the serial clock and chip-select input pins. The SSC Interface is designed to communicate with a microcontroller peer-to-peer for fast applications.

4.4.1.1 SSC Timing Definition

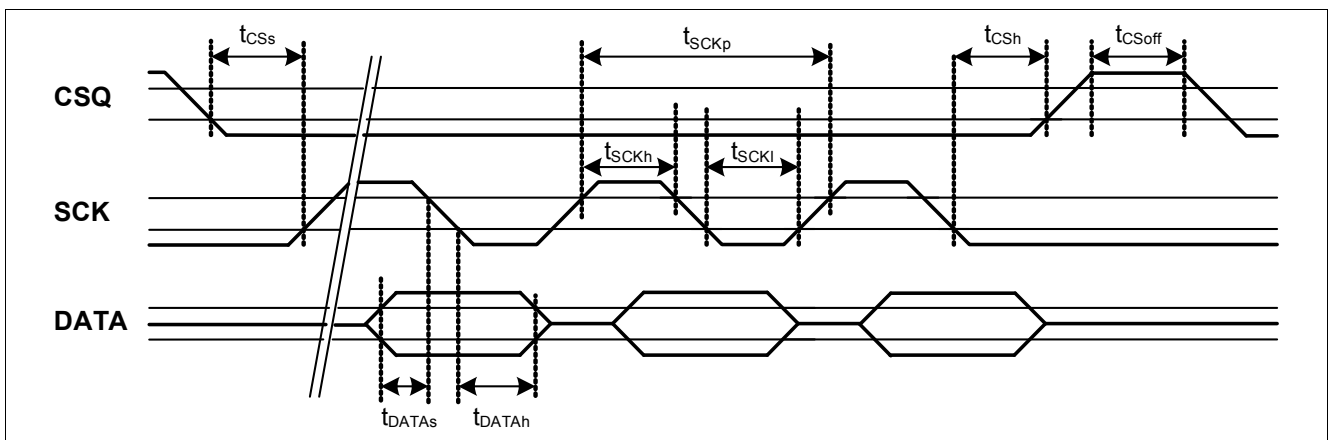

Figure 4-7 SSC timing

SSC Inactive Time (CS_{off})

The SSC inactive time defines the delay time after a transfer before the TLE5012B can be selected again.

Table 4-13 SSC push-pull timing specification

Parameter	Symbol	Values			Unit	Note / Test Condition
		Min.	Typ.	Max.		
SSC baud rate	f _{SSC}		8.0		Mbit/s	1)
CSQ setup time	t _{CSs}	105			ns	1)
CSQ hold time	t _{CSh}	105			ns	1)
CSQ off	t _{CSoFF}	600			ns	SSC inactive time ¹⁾
SCK period	t _{SCKp}	120	125		ns	1)
SCK high	t _{SCKh}	40			ns	1)
SCK low	t _{SCKl}	30			ns	1)
DATA setup time	t _{DATAs}	25			ns	1)
DATA hold time	t _{DATAh}	40			ns	1)
Write read delay	t _{wr_delay}	130			ns	1)
Update time	t _{CSupdate}	1			μs	See Figure 4-11 ¹⁾
SCK off	t _{SCKoff}	170			ns	1)

1) Not subject to production test - verified by design/characterization

Table 4-14 SSC open-drain timing specification

Parameter	Symbol	Values			Unit	Note / Test Condition
		Min.	Typ.	Max.		
SSC baud rate	f_{SSC}		2.0		Mbit/s	Pull-up Resistor = 1k Ω ¹⁾
CSQ setup time	t_{CSs}	300			ns	¹⁾
CSQ hold time	t_{CSH}	400			ns	¹⁾
CSQ off	t_{CSoff}	600			ns	SSC inactive time ¹⁾
SCK period	t_{SCKp}	500			ns	¹⁾
SCK high	t_{SCKh}		190		ns	¹⁾
SCK low	t_{SCKl}		190		ns	¹⁾
DATA setup time	t_{DATAs}	25			ns	¹⁾
DATA hold time	t_{DATAh}	40			ns	¹⁾
Write read delay	t_{wr_delay}	130			ns	¹⁾
Update time	$t_{CUpdate}$	1			μ s	See Figure 4-11 ¹⁾
SCK off	t_{SCKoff}	170			ns	¹⁾

1) Not subject to production test - verified by design/characterization

4.4.1.2 SSC Data Transfer

The SSC data transfer is word-aligned. The following transfer words are possible:

- Command Word (to access and change operating modes of the TLE5012B)
- Data words (any data transferred in any direction)
- Safety Word (confirms the data transfer and provides status information)

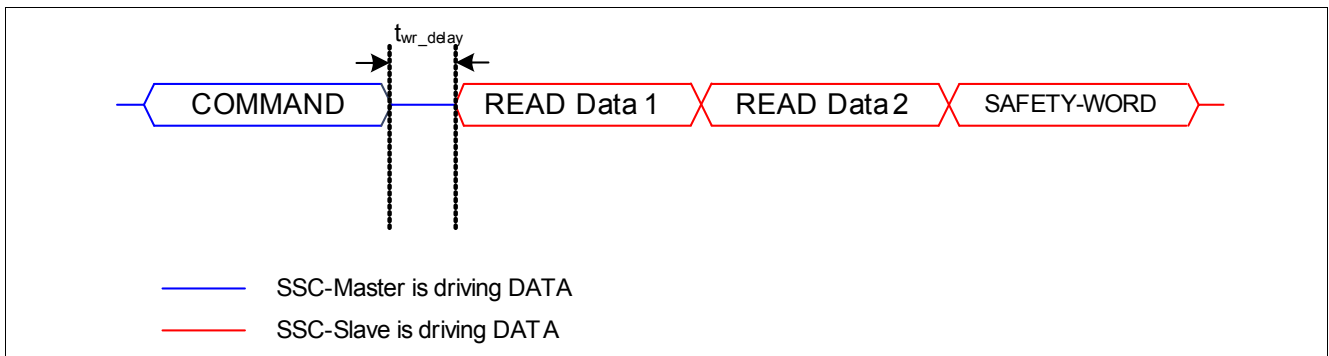

Figure 4-8 SSC data transfer (data-read example)

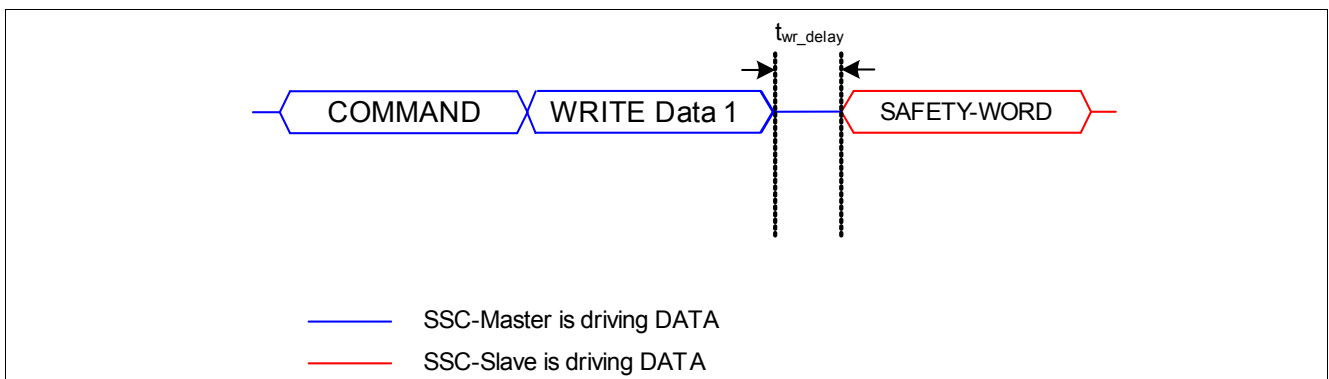

Figure 4-9 SSC data transfer (data-write example)

Command Word

SSC Communication between the TLE5012B and a microcontroller is generally initiated by a command word. The structure of the command word is shown in [Table 4-15](#). If an update is triggered by shortly pulling low CSQ without a clock on SCK a snapshot of all system values is stored in the update registers simultaneously. A read command with the UPD bit set then allows to readout this consistent set of values instead of the current values. Bits with an update buffer are marked by an “u” in the Type column in register descriptions. The initialization of such an update is described on page [33](#).

Table 4-15 Structure of the Command Word

Name	Bits	Description
RW	[15]	Read - Write 0: Write 1: Read
Lock	[14..11]	4-bit Lock Value 0000 _B : Default operating access for addresses 0x00:0x04 1010 _B : Configuration access for addresses 0x05:0x11

Table 4-15 Structure of the Command Word (cont'd)

Name	Bits	Description
UPD	[10]	Update-Register Access 0: Access to current values 1: Access to values in update buffer
ADDR	[9..4]	6-bit Address
ND	[3..0]	4-bit Number of Data Words

Safety Word

The safety word consists of the following bits:

Table 4-16 Structure of the Safety Word

Name	Bits	Description
STAT ¹⁾	Chip and Interface Status	
	[15]	Indication of chip reset or watchdog overflow (resets after readout) via SSC 0: Reset occurred 1: No reset
	[14]	System error (e.g. overvoltage; undervoltage; V_{DD-} , GND- off; ROM;...) 0: Error occurred (S_VR; S_DSPU; S_OV; S_XYOL; S_MAGOL; S_FUSE; S_ROM; S_ADCT) 1: No error
	[13]	Interface access error (access to wrong address; wrong lock) 0: Error occurred 1: No error
	[12]	Valid angle value (NO_GMR_A = 0; NO_GMR_XY = 0) 0: Angle value invalid 1: Angle value valid
RESP	[11..8]	Sensor number response indicator The sensor number bit is pulled low and the other bits are high
CRC	[7..0]	Cyclic Redundancy Check (CRC)

1) When an error occurs, the corresponding status bit in the safety word remains "low" until the STAT register (address 00_H) is read via SSC interface.

Bit Types

The types of bits used in the registers are listed here:

Table 4-17 Bit Types

Abbreviation	Function	Description
r	Read	Read-only registers
w	Write	Read and write registers
u	Update	Update buffer for this bit is present. If an update is issued and the Update-Register Access bit (UPD in Command Word) is set, the immediate values are stored in this update buffer simultaneously. This allows a snapshot of all necessary system parameters at the same time.

Data communication via SSC

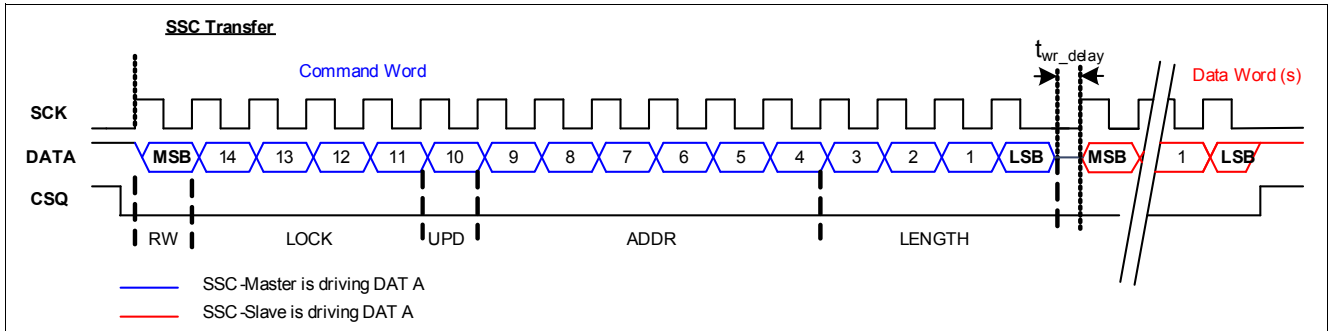

Figure 4-10 SSC bit ordering (read example)

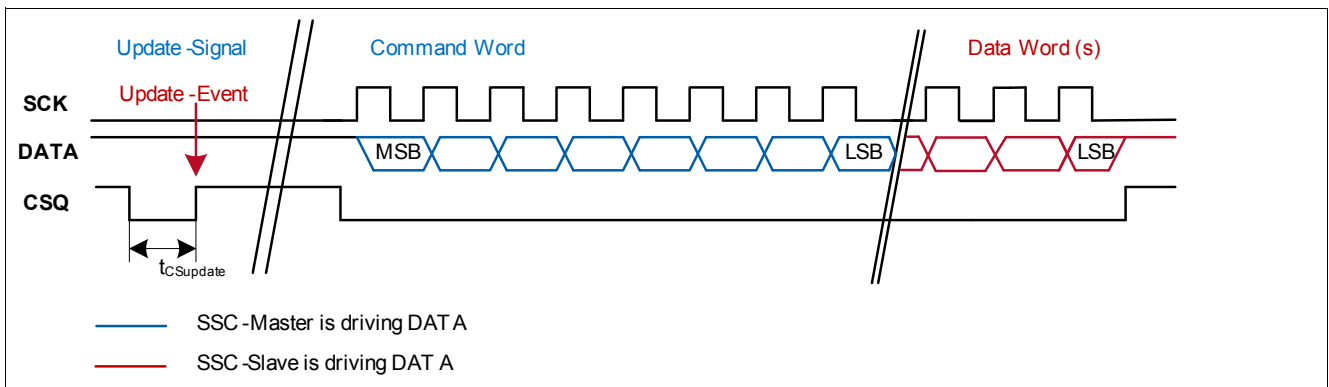

Figure 4-11 Update of update registers

The data communication via SSC interface has the following characteristics:

- The data transmission order is Most-Significant Bit (MSB) first, Last-Significant Bit (LSB) last.
- Data is put on the data line with the rising edge on SCK and read with the falling edge on SCK.
- The SSC Interface is word-aligned. All functions are activated after each transmitted word.
- After every data transfer with $ND \geq 1$, the 16-bit Safety Word is appended by the TLE5012B.
- A “high” condition on the Chip Select pin (CSQ) of the selected TLE5012B interrupts the transfer immediately. The CRC calculator is automatically reset.
- After changing the data direction, a delay t_{wr_delay} (see [Table 4-14](#)) has to be implemented before continuing the data transfer. This is necessary for internal register access.
- If in the Command Word the number of data is greater than 1 ($ND > 1$), then a corresponding number of consecutive registers is read, starting at the address given by ADDR.
- In case an overflow occurs at address $3F_H$, the transfer continues at address 00_H .
- If in the Command Word the number of data is zero ($ND = 0$), the register at the address given by ADDR is read, but no Safety Word is sent by the TLE5012B. This allows a fast readout of one register.
- At a rising edge of CSQ without a preceding data transfer (no SCK pulse, see [Figure 4-11](#)), the content of all registers which have an update buffer is saved into the buffer. This procedure serves to take a snapshot of all relevant sensor parameters at a given time. The content of the update buffer can then be read by sending a read command for the desired register and setting the UPD bit of the Command Word to “1”.
- After sending the Safety Word, the transfer ends. To start another data transfer, the CSQ has to be deselected once for at least t_{CSoff} .
- By default, the SSC interface is set to push-pull. The push-pull driver is active only if the TLE5012B has to send data, otherwise the DATA pin is set to high-impedance.

Cyclic Redundancy Check (CRC)

- This CRC is according to the J1850 Bus Specification.
- Every new transfer restarts the CRC generation.
- Every Byte of a transfer will be taken into account to generate the CRC (also the sent command(s)).
- Generator polynomial: $X^8+X^4+X^3+X^2+1$, but for the CRC generation the fast-CRC generation circuit is used (see Figure 4-12)
- The seed value of the fast CRC circuit is '11111111_B'.
- The remainder is inverted before transmission.

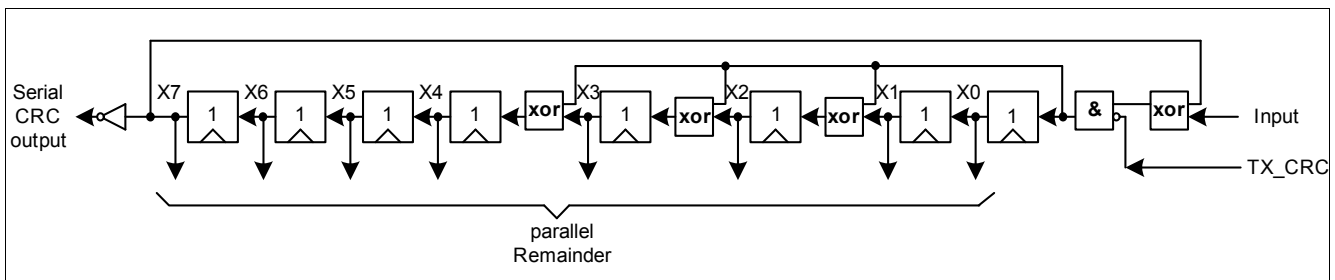

Figure 4-12 Fast CRC polynomial division circuit

4.4.2 Pulse Width Modulation (PWM) Interface

The Pulse Width Modulation (PWM) interface can be selected via SSC (IF_MD = '01').

The PWM update rate can be programmed within the register 0E_H (IFAB_RES) in the following steps:

- ~0.25 kHz with 12-bit resolution
- ~0.5 kHz with 12-bit resolution
- ~1.0 kHz with 12-bit resolution
- ~2.0 kHz with 12-bit resolution

PWM uses a square wave with constant frequency whose duty cycle is modulated according to the last measured angle value (AVAL register).

Figure 4-13 shows the principal behavior of a PWM with various duty cycles and the definition of timing values. The duty cycle of a PWM is defined by the following general formulas:

$$\begin{aligned}
 \text{Duty Cycle} &= \frac{t_{on}}{t_{PWM}} \\
 t_{PWM} &= t_{on} + t_{off} \\
 f_{PWM} &= \frac{1}{t_{PWM}}
 \end{aligned}
 \tag{4.2}$$

The duty cycle range between 0 - 6.25% and 93.75 - 100% is used only for diagnostic purposes. In case the sensor detects an error, the corresponding error bit in the Status register is set and the PWM duty cycle goes to the lower (0 - 6.25%) or upper (93.75 - 100%) diagnostic range, depending on the kind of error (see “Output duty cycle range” in Table 4-18). Except for an S_ADCT error, an error is only indicated by the corresponding diagnostic duty-cycle as long as it persists, but at least once. However the value in the status register will remain until a read-out via the SSC interface or a chip reset is performed. An S_ADCT error on the other side will be transmitted until the next chip reset. This fail-safe diagnostic function can be disabled via the MOD_4 register.

Sensors with preset PWM are available as TLE5012B E50x0.

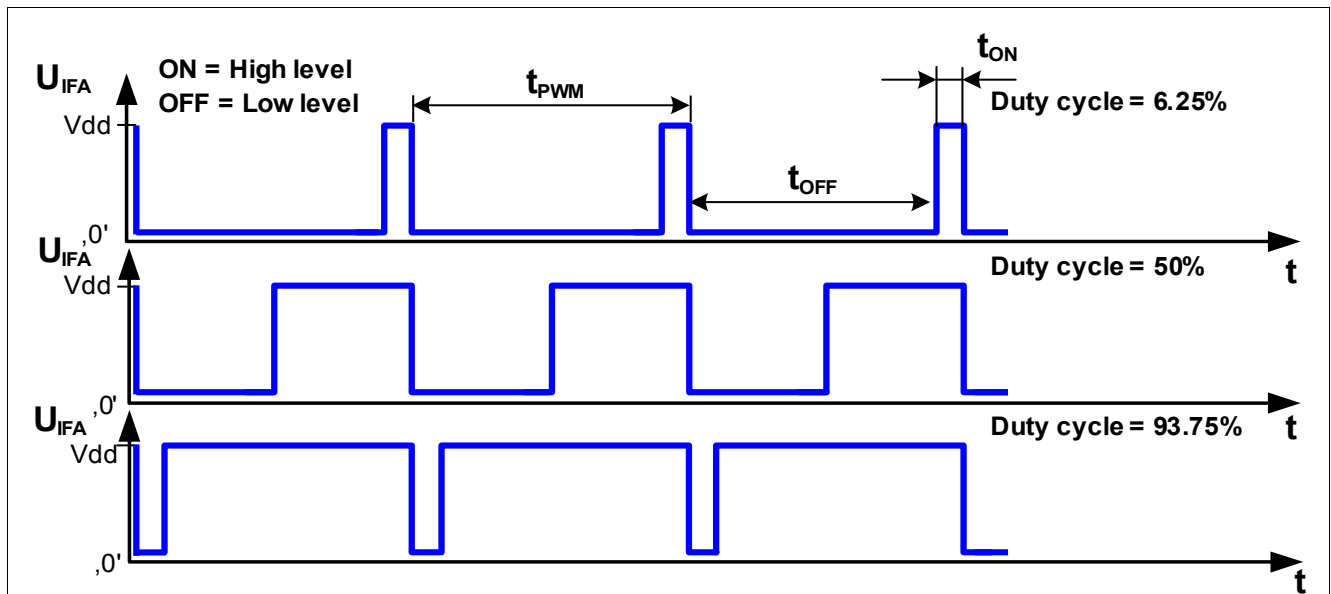

Figure 4-13 Typical example of a PWM signal

Table 4-18 PWM interface

Parameter	Symbol	Values			Unit	Note / Test Condition
		Min.	Typ.	Max.		
PWM output frequencies (Selectable by IFAB_RES)	f _{PWM1}	232	244	262	Hz	1)
	f _{PWM2}	464	488	525	Hz	1)
	f _{PWM3}	929	977	1050	Hz	1)
	f _{PWM4}	1855	1953	2099	Hz	1)
Output duty cycle range	DY _{PWM}	6.25		93.75	%	Absolute angle ¹⁾
			2		%	Electrical Error (S_RST; S_VR) ¹⁾
			98		%	System error (S_FUSE; S_OV; S_XYOL; S_MAGOL; S_ADCT) ¹⁾
		0		1	%	Short to GND ¹⁾
		99		100	%	Short to V _{DD} , power loss ¹⁾

1) Not subject to production test - verified by design/characterization

The PWM frequency is derived from the digital clock via

$$f_{\text{PWM}} = \frac{f_{\text{DIG}} * 2^{\text{IFAB_RES}}}{24 * 4096} \tag{4.3}$$

The min/max values given in [Table 4-18](#) take into account the internal digital clock variation specified in [Chapter 4.3.7](#). If external clock is used, the variation of the PWM frequency can be derived from the variation of the external clock using [Equation \(4.3\)](#).

4.4.3 Short PWM Code (SPC)

The Short PWM Code (SPC) is a synchronized data transmission based on the SENT protocol (Single Edge Nibble Transmission) defined by SAE J2716. As opposed to SENT, which implies a continuous transmission of data, the SPC protocol transmits data only after receiving a specific trigger pulse from the microcontroller. The required length of the trigger pulse depends on the sensor number, which is configurable. Thereby, SPC allows the operation of up to four sensors on one bus line.

SPC enables the use of enhanced protocol functionality due to the ability to select between various sensor slaves (ID selection). The slave number (S_NR) can be given by the external circuit of SCK and IFC pin. In case of V_{DD} on SCK, the S_NR[0] can be set to 1 and in the case of GND on SCK the S_NR[0] is equal to 0. S_NR[1] can be adjusted in the same way by the IFC pin.

As in SENT, the time between two consecutive falling edges defines the value of a 4-bit nibble, thus representing numbers between 0 and 15. The transmission time therefore depends on the transmitted data values. The single edge is defined by a 3 Unit Time (UT, see [Chapter 4.4.3.1](#)) low pulse on the output, followed by the high time defined in the protocol (nominal values, may vary depending on the tolerance of the internal oscillator and the influence of external circuitry). All values are multiples of a unit time frame concept. A transfer consists of the following parts ([Figure 4-14](#)):

- A trigger pulse by the master, which initiates the data transmission
- A synchronization period of 56 UT (in parallel, a new sample is calculated)
- A status nibble of 12-27 UT
- Between 3 and 6 data nibbles of 12-27 UT
- A CRC nibble of 12-27 UT
- An end pulse to terminate the SPC transmission

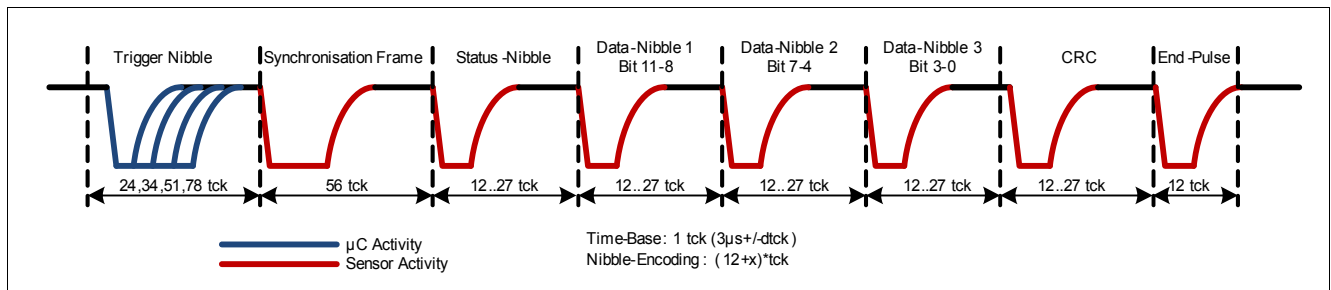

Figure 4-14 SPC frame example

The CRC checksum includes the status nibble and the data nibbles, and can be used to check the validity of the decoded data. The sensor is available for the next trigger pulse 90μs after the falling edge of the end pulse (see [Figure 4-15](#)).

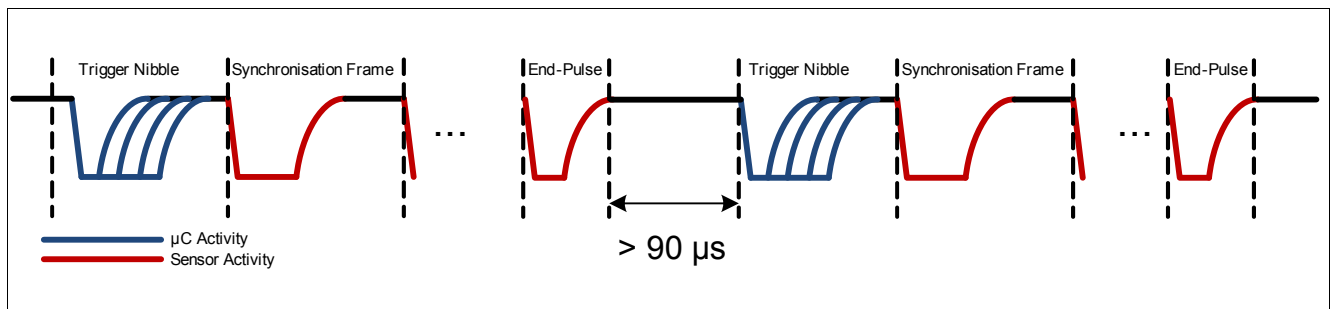

Figure 4-15 SPC pause timing diagram

In SPC mode, the sensor does not continuously calculate an angle from the raw data. Instead, the angle calculation is started by the trigger nibble from the master. In this mode, the AVAL register, which stores the angle value and can be read via SSC, contains the angle which was calculated after the last SPC trigger nibble.

In parallel to SPC, the SSC interface can be used for individual configuration. The number of transmitted SPC nibbles can be changed to customize the amount of information sent by the sensor. The frame contains a 16-bit angle value and an 8-bit temperature value in the full configuration ([Table 4-19](#)).

Sensors with preset SPC are available as TLE5012B E9000

Table 4-19 Frame configuration

Frame type	IFAB_RES	Data nibbles
12-bit angle	00	3 nibbles
16-bit angle	01	4 nibbles
12-bit angle, 8-bit temperature	10	5 nibbles
16-bit angle, 8-bit temperature	11	6 nibbles

The status nibble, which is sent with each SPC data frame, provides an error indication similar to the Safety Word of the SSC protocol. In case the sensor detects an error, the corresponding error bit in the Status register is set and either the bit SYS_ERR or the bit ELEC_ERR of the status nibble will be “high”, depending on the kind of error (see [Table 4-20](#)). Except for an S_ADCT error, an error is only indicated by the corresponding error bit in the status nibble as long as it persists, but at least once. However the value in the status register will remain until a read-out via the SSC interface or a chip reset is performed. An S_ADCT error on the other side will be transmitted until the next chip reset. The fail-safe diagnostic function can be disabled via the MOD_4 register.

Table 4-20 Structure of status nibble

Name	Bits	Description
SYS_ERR	[3]	Indication of system error (S_FUSE, S_OV, S_XYOL, S_MAGOL, S_ADCT) 0: No system error 1: System error occurred
ELEC_ERR	[2]	Indication of electrical error (S_RST, S_VR) 0: No electrical error 1: Electrical error occurred
S_NR	[1]	Slave number bit 1 (level on IFC)
	[0]	Slave number bit 0 (level on SCK)

4.4.3.1 Unit Time Setup

The basic SPC protocol unit time granularity is defined as 3 μ s. Every timing is a multiple of this basic time unit. To achieve more flexibility, trimming of the unit time can be done within IFAB_HYST. This enables a setup of different unit times.

Table 4-21 Predivider setting

Parameter	Symbol	Values			Unit	Note / Test Condition
		Min.	Typ.	Max.		
Unit time	t_{Unit}		3.0		μ s	IFAB_HYST = 00 ¹⁾
			2.5			IFAB_HYST = 01 ¹⁾
			2.0			IFAB_HYST = 10 ¹⁾
			1.5			IFAB_HYST = 11 ¹⁾

1) Not subject to production test - verified by design/characterization

4.4.3.2 Master Trigger Pulse Requirements

An SPC transmission is initiated by a master trigger pulse on the IFA pin. To detect a low-level on the IFA pin, the voltage must be below a threshold V_{th} . The sensor detects that the IFA line has been released as soon as V_{th} is crossed. **Figure 4-16** shows the timing definitions for the master pulse. The master low time $t_{m\text{low}}$ as well as the total trigger time $t_{m\text{tr}}$ are given in **Table 4-22**.

If the master low time exceeds the maximum low time, the sensor does not respond and is available for a next triggering 30 μs after the master pulse crosses V_{thr} . $t_{m\text{d,tot}}$ is the delay between internal triggering of the falling edge in the sensor and the triggering of the ECU.

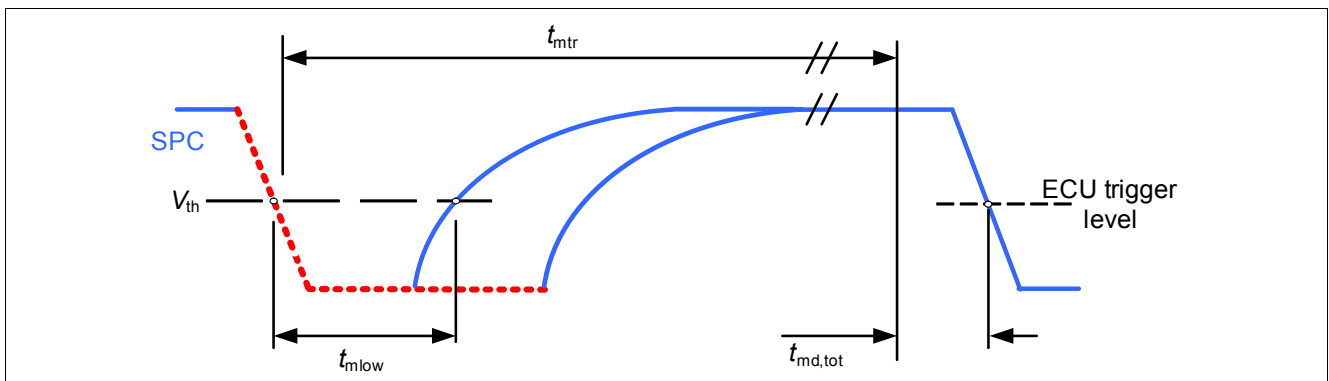

Figure 4-16 SPC Master pulse timing

Table 4-22 Master pulse parameters

Parameter	Symbol	Values			Unit	Note / Test Condition
		Min.	Typ.	Max.		
Threshold	V_{th}		50		% of V_{DD}	¹⁾
Threshold hysteresis	$V_{th\text{hyst}}$		8		% of V_{DD}	$V_{DD} = 5\text{ V}^{1)}$
			3		V_{DD}	$V_{DD} = 3\text{ V}^{1)}$
Total trigger time	$t_{m\text{tr}}$		90		UT	SPC_Trigger = 0; ¹⁾²⁾
			$t_{m\text{low}} + 12$		UT	SP_Trigger = 1 ¹⁾
Master low time	$t_{m\text{low}}$	8	12	14	UT	S_NR = 00 ¹⁾
		16	22	27		S_NR = 01 ¹⁾
		29	39	48		S_NR = 10 ¹⁾
		50	66	81		S_NR = 11 ¹⁾
Master delay time	$t_{m\text{d,tot}}$		5.8		μs	¹⁾

1) Not subject to production test - verified by design/characterization

2) Trigger time in the sensor is fixed to the number of units specified in the "typ." column, but the effective trigger time varies due to the sensor's clock variation

4.4.3.3 Checksum Nibble Details

The checksum nibble is a 4-bit CRC of the data nibbles including the status nibble. The CRC is calculated using a polynomial $x^4+x^3+x^2+1$ with a seed value of 0101_B. The remainder after the last data nibble is transmitted as CRC.

4.4.4 Hall Switch Mode (HSM)

The **Hall Switch Mode (HSM)** within the TLE5012B makes it possible to emulate the output of 3 Hall switches. Hall switches are often used in electrical commutated motors to determine the rotor position. With these 3 output signals, the motor will be commutated in the right way. Depending on which pole pairs of the rotor are used, various electrical periods have to be controlled. This is selectable within $0E_H$ (HSM_PLP). **Figure 4-17** depicts the three output signals with the relationship between electrical angle and mechanical angle. The mechanical 0° point is always used as reference.

The HSM is generally used with push-pull output, but it can be changed to open-drain within the register IFAB_OD. Sensors with preset HSM are available as TLE5012B E3005.

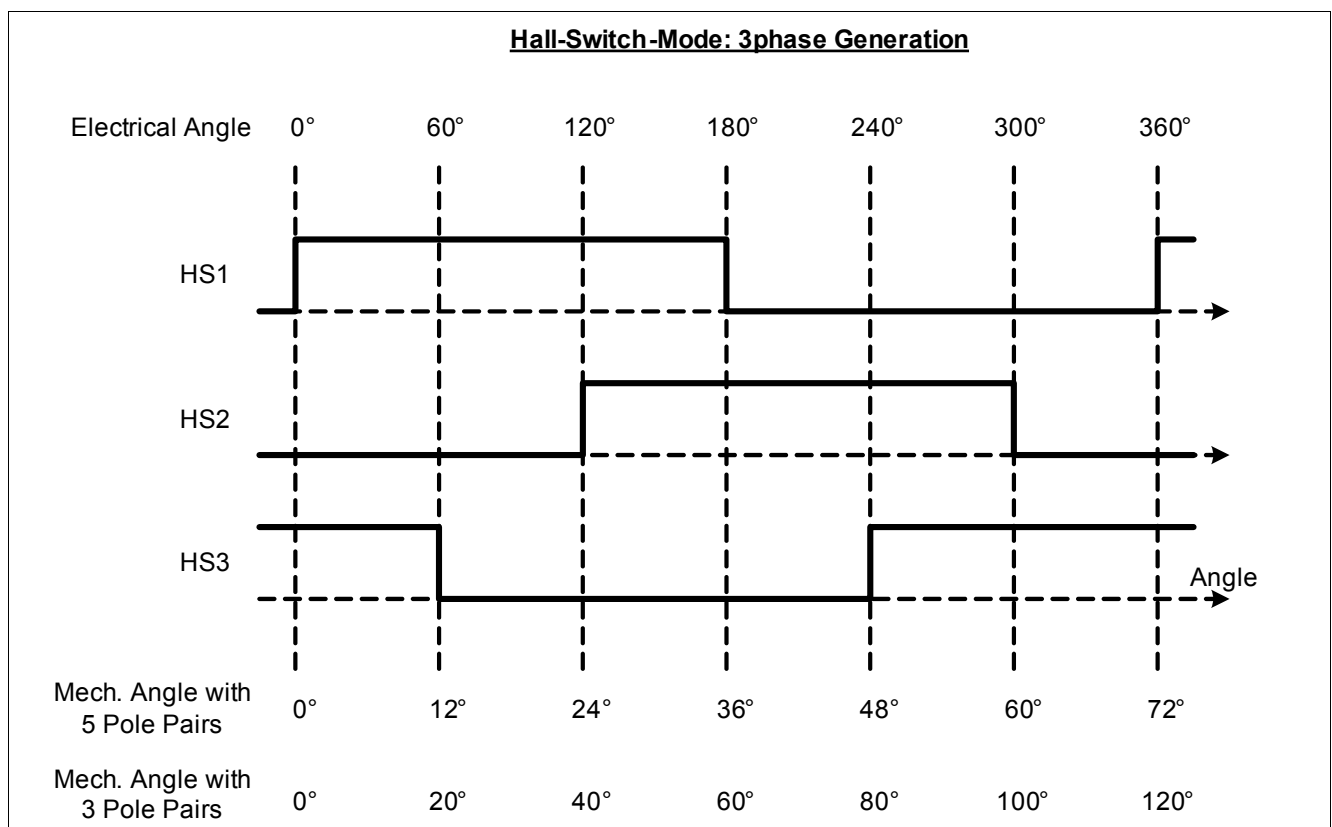

Figure 4-17 Hall Switch Mode

The HSM Interface can be selected via SSC (IF_MD = 010).

Table 4-23 Hall Switch Mode

Parameter	Symbol	Values			Unit	Note / Test Condition
		Min.	Typ.	Max.		
Rotation speed	n			10000	rpm	Mechanical ²⁾

Table 4-23 Hall Switch Mode (cont'd)

Parameter	Symbol	Values			Unit	Note / Test Condition
		Min.	Typ.	Max.		
Electrical angle accuracy	α_{elect}		0.6	1	°	1 pole pair with autocalibration ¹⁾²⁾
			1.2	2	°	2 pole pairs with autocal. ¹⁾²⁾
			1.8	3	°	3 pole pairs with autocal. ¹⁾²⁾
			2.4	4	°	4 pole pairs with autocal. ¹⁾²⁾
			3.0	5	°	5 pole pairs with autocal. ¹⁾²⁾
			3.6	6	°	6 pole pairs with autocal. ¹⁾²⁾
			4.2	7	°	7 pole pairs with autocal. ¹⁾²⁾
			4.8	8	°	8 pole pairs with autocal. ¹⁾²⁾
			5.4	9	°	9 pole pairs with autocal. ¹⁾²⁾
			6.0	10	°	10 pole pairs with autocal. ¹⁾²⁾
			6.6	11	°	11 pole pairs with autocal. ¹⁾²⁾
			7.2	12	°	12 pole pairs with autocal. ¹⁾²⁾
			7.8	13	°	13 pole pairs with autocal. ¹⁾²⁾
			8.4	14	°	14 pole pairs with autocal. ¹⁾²⁾
	9.0	15	°	15 pole pairs with autocal. ¹⁾²⁾		
	9.6	16	°	16 pole pairs with autocal. ¹⁾²⁾		
Mechanical angle switching hysteresis	α_{HShystm}	0		0.703	°	Selectable by IFAB_HYST ²⁾³⁾⁴⁾

Table 4-23 Hall Switch Mode (cont'd)

Parameter	Symbol	Values			Unit	Note / Test Condition
		Min.	Typ.	Max.		
Electrical angle switching hysteresis ⁵⁾	$\alpha_{HShystel}$		0.70		°	1 pole pair; IFAB_HYST=11 ¹⁾²⁾
			1.41		°	2 pole pairs; IFAB_HYST=11 ¹⁾²⁾
			2.11		°	3 pole pairs; IFAB_HYST=11 ¹⁾²⁾
			2.81		°	4 pole pairs; IFAB_HYST=11 ¹⁾²⁾
			3.52		°	5 pole pairs; IFAB_HYST=11 ¹⁾²⁾
			4.22		°	6 pole pairs; IFAB_HYST=11 ¹⁾²⁾
			4.92		°	7 pole pairs; IFAB_HYST=11 ¹⁾²⁾
			5.62		°	8 pole pairs; IFAB_HYST=11 ¹⁾²⁾
			6.33		°	9 pole pairs; IFAB_HYST=11 ¹⁾²⁾
			7.03		°	10 pole pairs; IFAB_HYST=11 ¹⁾²⁾
			7.73		°	11 pole pairs; IFAB_HYST=11 ¹⁾²⁾
			8.44		°	12 pole pairs; IFAB_HYST=11 ¹⁾²⁾
			9.14		°	13 pole pairs; IFAB_HYST=11 ¹⁾²⁾
			9.84		°	14 pole pairs; IFAB_HYST=11 ¹⁾²⁾
			10.55		°	15 pole pairs; IFAB_HYST=11 ¹⁾²⁾
			11.25		°	16 pole pairs; IFAB_HYST=11 ¹⁾²⁾
Fall time	t_{HSfall}		0.02	1	μs	$R_L = 2.2k\Omega; C_L < 50pF^2)$
Rise time	t_{HSrise}		0.4	1	μs	$R_L = 2.2k\Omega; C_L < 50pF^2)$

- 1) Depends on internal oscillator frequency variation ([Section 4.3.7](#))
- 2) Not subject to production test - verified by design/characterization
- 3) GMR hysteresis not considered
- 4) Minimum hysteresis without switching
- 5) The hysteresis has to be considered only at change of rotation direction

To avoid switching due to mechanical vibrations of the rotor, an artificial hysteresis is recommended ([Figure 4-18](#)).

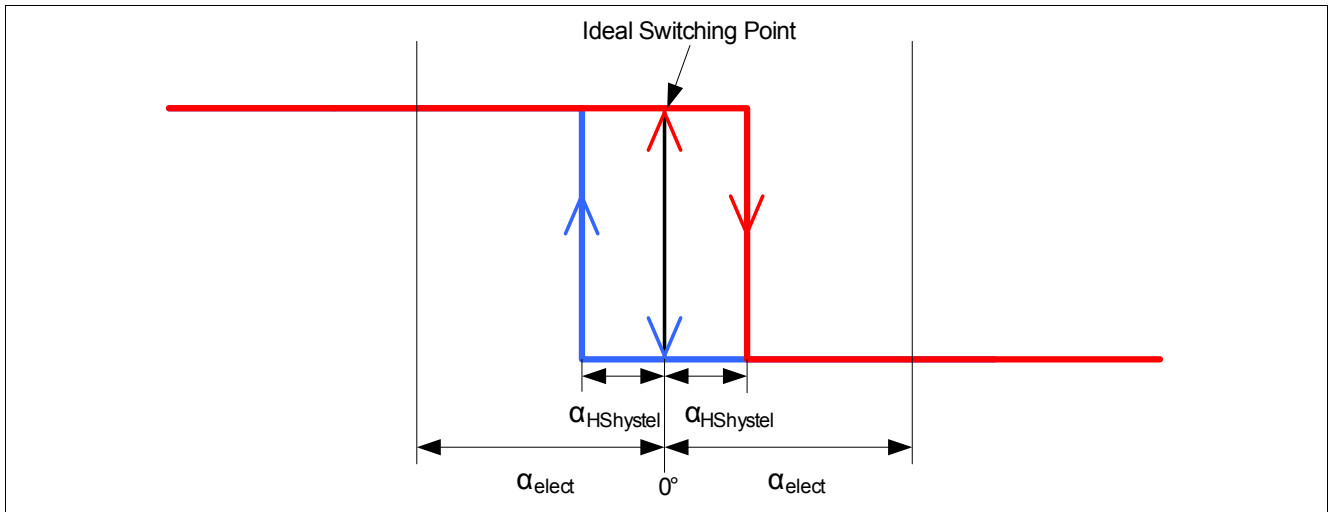

Figure 4-18 HS hysteresis

4.4.5 Incremental Interface (IIF)

The Incremental Interface (IIF) emulates the operation of an optical quadrature encoder with a 50% duty cycle. It transmits a square pulse per angle step, where the width of the steps can be configured from 9bit (512 steps per full rotation) to 12bit (4096 steps per full rotation) within the register MOD_4 (IFAB_RES). The rotation direction is given either by the phase shift between the two channels IFA and IFB (A/B mode) or by the level of the IFB channel (Step/Direction mode), as shown in Figure 4-19 and Figure 4-20. The incremental interface can be configured for A/B mode or Step/Direction mode in register MOD_1 (IIF_MOD).

Using the Incremental Interface requires an up/down counter on the microcontroller, which counts the pulses and thus keeps track of the absolute position. The counter can be synchronized periodically by using the SSC interface in parallel. The angle value (AVAL register) read out by the SSC interface can be compared to the stored counter value. In case of a non-synchronization, the microcontroller adds the difference to the actual counter value to synchronize the TLE5012B with the microcontroller.

After startup, the IIF transmits a number of pulses which correspond to the actual absolute angle value. Thus, the microcontroller gets the information about the absolute position. The Index Signal that indicates the zero crossing is available on the IFC pin.

Sensors with preset IIF are available as TLE5012B E1000.

A/B Mode

The phase shift between phases A and B indicates either a clockwise (A follows B) or a counterclockwise (B follows A) rotation of the magnet.

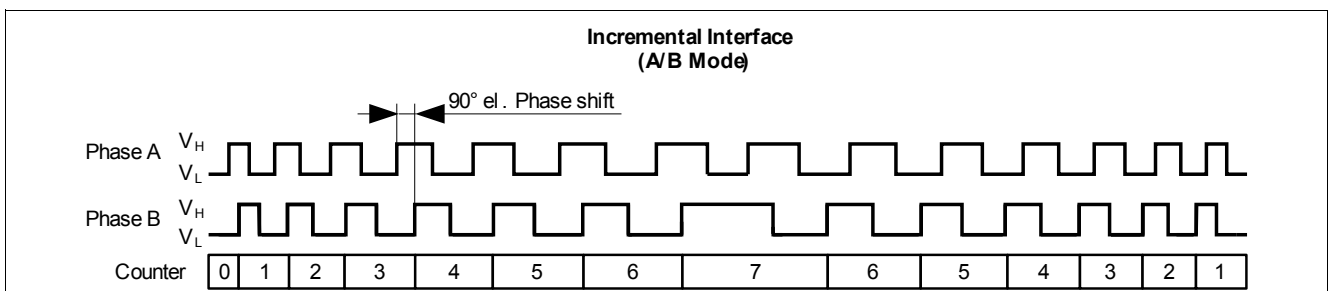

Figure 4-19 Incremental interface with A/B mode

Step/Direction Mode

Phase A pulses out the increments and phase B indicates the direction.

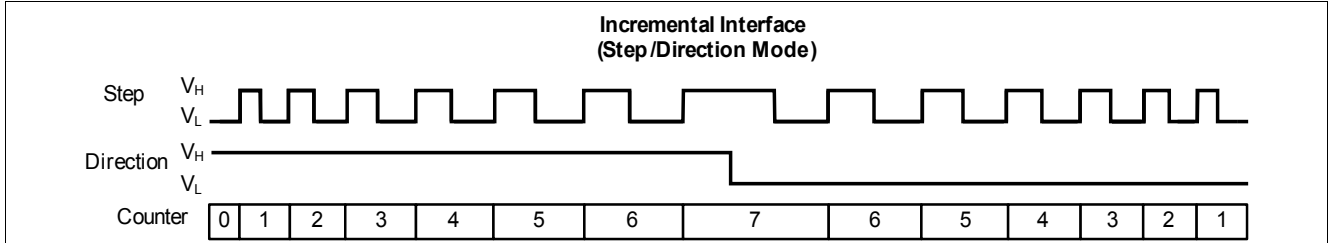

Figure 4-20 Incremental interface with Step/Direction mode

Table 4-24 Incremental Interface

Parameter	Symbol	Values			Unit	Note / Test Condition
		Min.	Typ.	Max.		
Incremental output frequency	f_{inc}			1.0	MHz	Frequency of phase A and phase B ¹⁾
Index pulse width	t_{0°		5		μ s	0 ¹⁾

1) Not subject to production test - verified by design/characterization

4.5 Test Mechanisms

4.5.1 ADC Test Vectors

In order to test the correct functionality of the ADCs, the ADC inputs can be switched from the GMR bridge outputs to a chain of fixed resistors which act as a voltage divider. The ADCs are then fed with test vectors of fixed voltages to simulate a set of magnet positions. The functionality of the ADCs is verified by checking the angle value (AVAL register) for each test vector. This test is activated via SSC command within the SIL register (ADCTV_EN). Registers ADCTV_Y and ADCTV_X are used to select the test vector, as shown in [Figure 4-21](#).

The following X/Y ADC values can be programmed:

- 4 points, circle amplitude = 70% (0°, 90°, 180°, 270°)
- 8 points, circle amplitude = 100% (0°, 45°, 90°, 135°, 180°, 225°, 270°, 315°)
- 8 points, circle amplitude = 122.1% (35.3°, 54.7°, 125.3°, 144.7°, 215.3°, 234.7°, 305.3°, 324.7°)
- 4 points, circle amplitude = 141.4% (45°, 135°, 225°, 315°)

Note: The 100% values typically correspond to 21700 digits and the 70% values to 15500 digits.

Table 4-25 ADC test vectors

Register bits	X/Y values (decimal)		
	Min.	Typ.	Max.
000		0	
001		15500	
010		21700	
011		32767	
100 ¹⁾		0	
101		-15500	

Table 4-25 ADC test vectors (cont'd)

Register bits	X/Y values (decimal)		
	Min.	Typ.	Max.
110		-21700	
111		-32768	

1) Not allowed to use

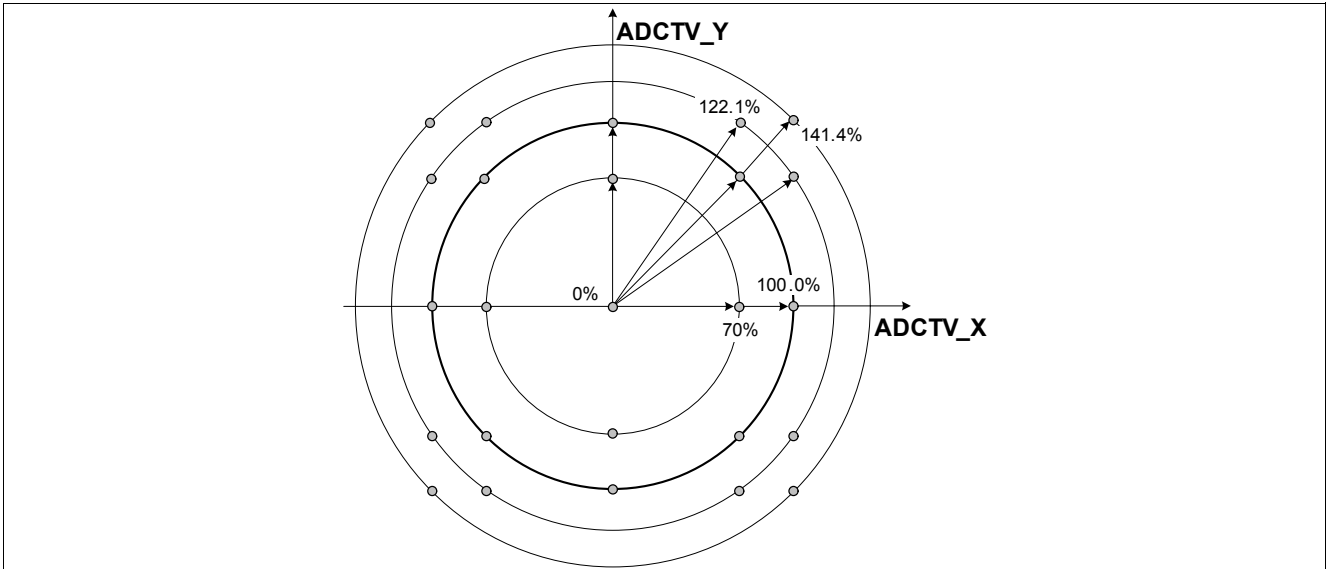

Figure 4-21 ADC test vectors

4.6 Supply Monitoring

The internal voltage nodes of the TLE5012B are monitored by a set of comparators in order to ensure error-free operation. An over- or undervoltage condition must be active at least 256 periods of the digital clock to set the corresponding error bits in the Status register. This works as digital spike suppression.

Over- or undervoltage errors trigger the S_VR bit of Status register. This error condition is signaled via the in the Safety Word of the SSC protocol, the status nibble of the SPC interface or the lower diagnostic range of the PWM interface.

Table 4-26 Test comparator threshold voltages

Parameter	Symbol	Values			Unit	Note / Test Condition
		Min.	Typ.	Max.		
Overvoltage detection	V _{OVG}		2.80		V	1)
	V _{OVA}		2.80		V	1)
	V _{OVD}		2.80		V	1)
V _{DD} overvoltage	V _{DDOV}		6.05		V	1)
V _{DD} undervoltage	V _{DDUV}		2.70		V	1)
GND - off voltage	V _{GNDoff}		-0.55		V	1)
V _{DD} - off voltage	V _{VDDoff}		0.55		V	1)
Spike filter delay	t _{DEL}		10		µS	1)

1) Not subject to production test - verified by design/characterization

4.6.1 Internal Supply Voltage Comparators

Every voltage regulator has an overvoltage (OV) comparator to detect malfunctions. If the nominal output voltage of 2.5 V is larger than V_{OVG} , V_{OVA} and V_{OVD} , then this overvoltage comparator is activated.

4.6.2 V_{DD} Overvoltage Detection

The overvoltage detection comparator monitors the external supply voltage at the V_{DD} pin.

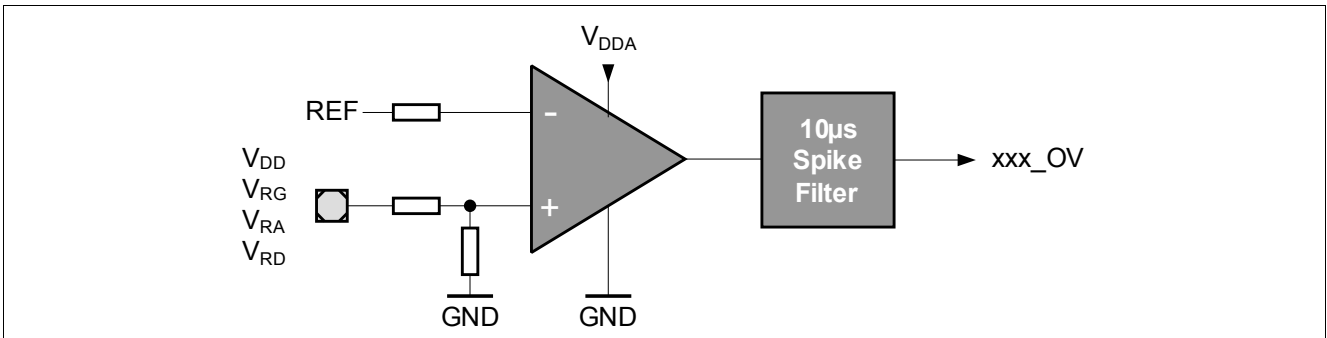

Figure 4-22 Overvoltage comparator

4.6.3 GND - Off Comparator

The GND - Off comparator is used to detect a voltage difference between the GND pin and SCK. This circuit can detect a disconnection of the supply GND Pin.

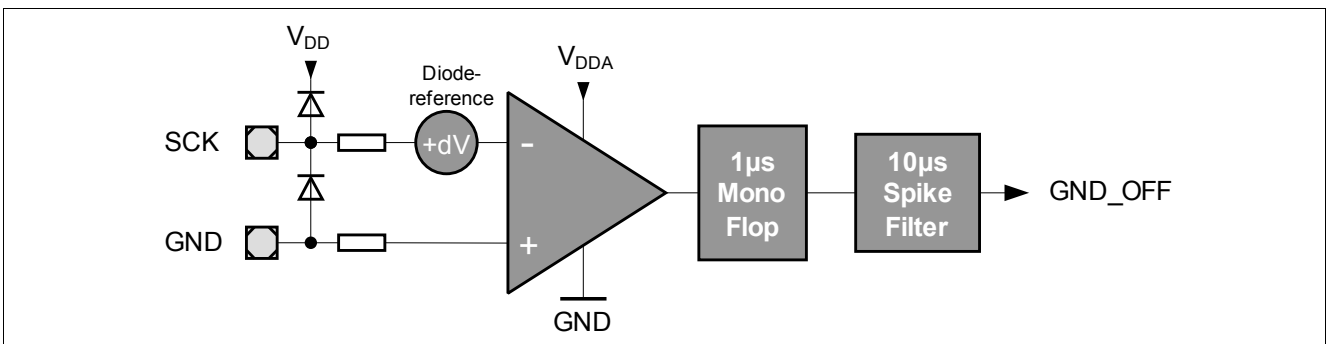

Figure 4-23 GND - off comparator

4.6.4 V_{DD} - Off Comparator

The V_{DD} - Off comparator detects a disconnection of the V_{DD} pin supply voltage. In this case, the TLE5012B is supplied by the SCK and CSQ input pins via the ESD structures.

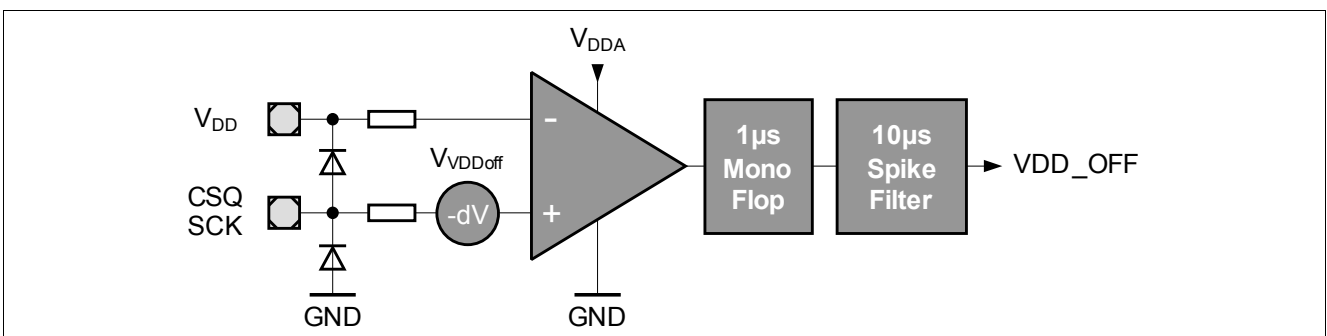

Figure 4-24 V_{DD} - off comparator

5 Pre-Configured Derivates

Derivates of the 5012B are available with different pre-configured register settings for specific applications. The configuration of all derivates can be changed via SSC interface.

5.1 IIF-type: E1000

The TLE5012B-E1000 is preconfigured for Incremental Interface and fast angle update period (42.7 μ s). It is most suitable for BLDC motor commutation.

- Autocalibration mode 1 enabled.
- Prediction enabled.
- Hysteresis is set to 0.703°.
- 12bit mode, one count per 0.088° angle step.
- Incremental Interface A/B mode.

5.2 HSM-type: E3005

The TLE5012B-E3005 is preconfigured for Hall-Switch-Mode and fast angle update period (42.7 μ s). It is most suitable as a replacement for three Hall switches for BLDC motor commutation.

- Number of pole pairs is set to 5.
- Autocalibration mode 1 enabled.
- Prediction enabled.
- Hysteresis is set to 0.703°.

5.3 PWM-type: E5000

The TLE5012B-E5000 is preconfigured for Pulse-Width-Modulation interface. It is most suitable for steering angle and actuator position sensing.

- Filter update period is 85.4 μ s.
- PWM frequency is 244 Hz.
- Autocalibration, Prediction, and Hysteresis are disabled.

5.4 PWM-type: E5020

The TLE5012B-E5020 is preconfigured for Pulse-Width-Modulation interface with high frequency. It is most suitable for steering angle and actuator position sensing.

- Filter update period is 42.7 μ s.
- PWM frequency is 1953 Hz.
- Autocalibration mode 2 enabled.
- Prediction and Hysteresis are disabled.
- PWM interface is set to open-drain output.

5.5 SPC-type: E9000

The TLE5012B-E9000 is preconfigured for Short-PWM-Code interface. It is most suitable for steering angle and actuator position sensing.

- Filter update period is 85.4 μ s.
- Autocalibration, Prediction, and Hysteresis are disabled.
- SPC unit time is 3 μ s.
- SPC interface is set to open-drain output.

6 Package Information

6.1 Package Parameters

Table 6-1 Package Parameters

Parameter	Symbol	Limit Values			Unit	Notes
		Min.	Typ.	Max.		
Thermal resistance	R_{thJA}		150	200	K/W	Junction to air ¹⁾
	R_{thJC}			75	K/W	Junction to case
	R_{thJL}			85	K/W	Junction to lead
Soldering moisture level		MSL 3				260°C
Lead Frame		Cu				
Plating		Sn 100%				> 7 μm

1) according to Jedec JESD51-7

6.2 Package Outline

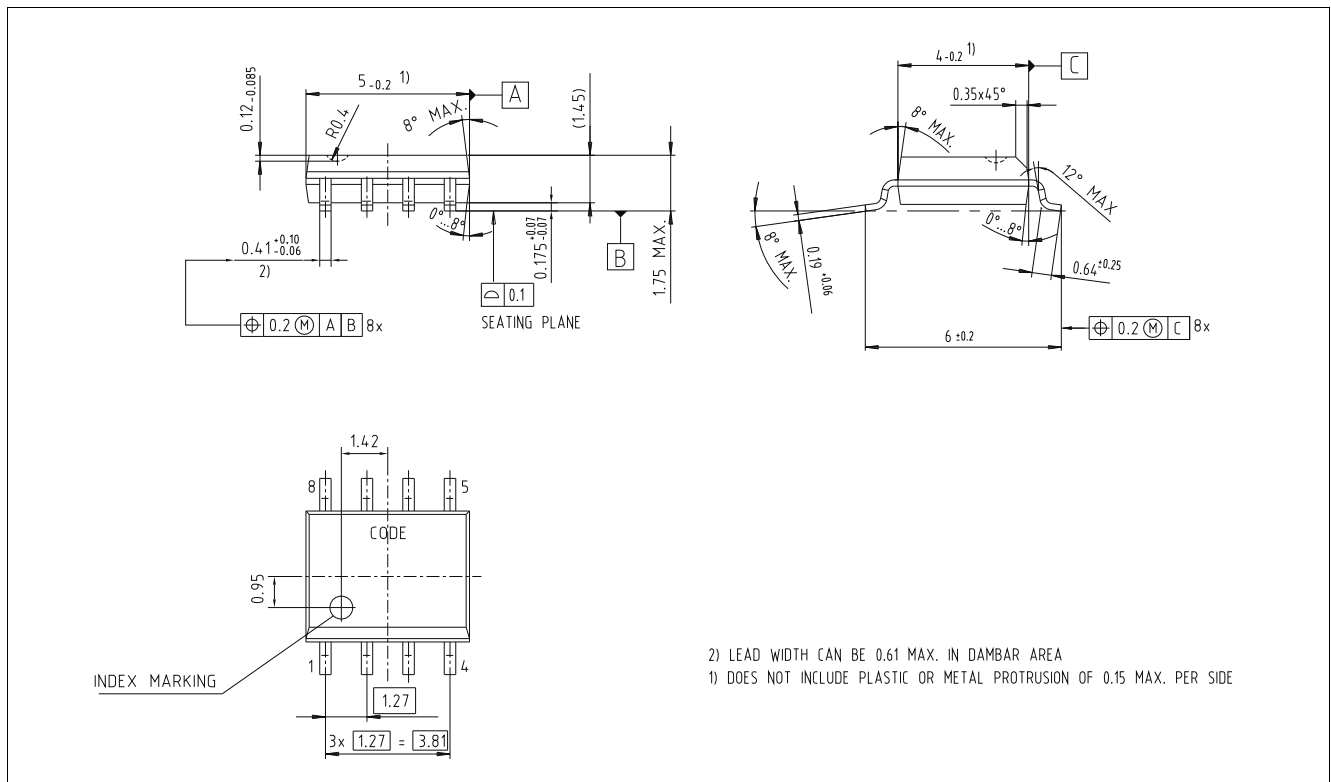

Figure 6-1 PG-DSO-8 package dimension

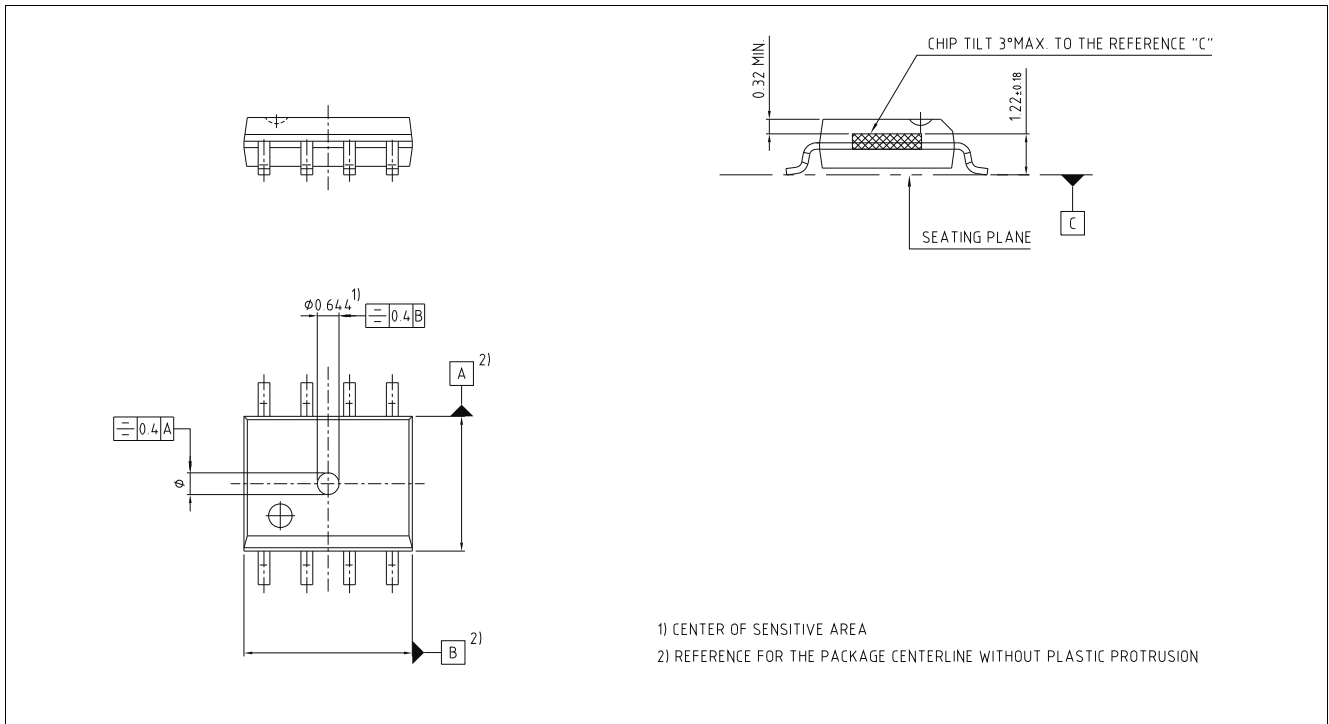

Figure 6-2 Position of sensing element

Table 6-2 Sensor IC placement tolerances in package

Parameter	Values		Unit	Notes
	Min.	Max.		
position eccentricity	-200	200	µm	in X- and Y-direction
rotation	-3	3	°	affects zero position offset of sensor
tilt	-3	3	°	

6.3 Footprint

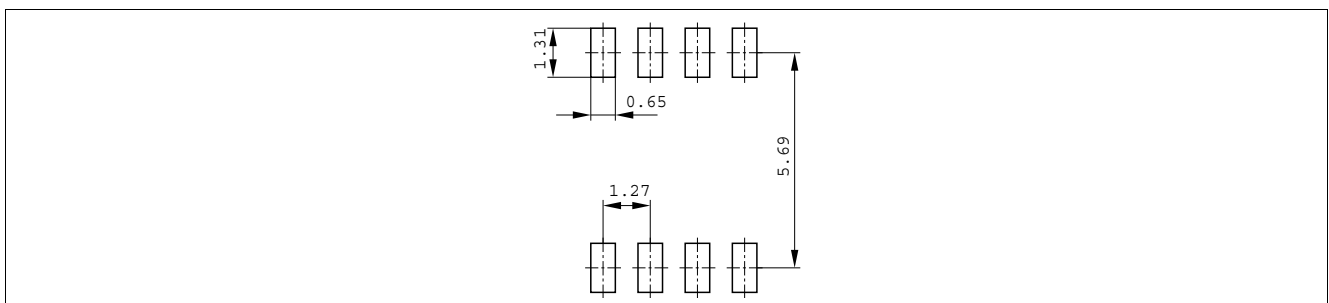

Figure 6-3 Footprint of PG-DSO-8

6.4 Packing

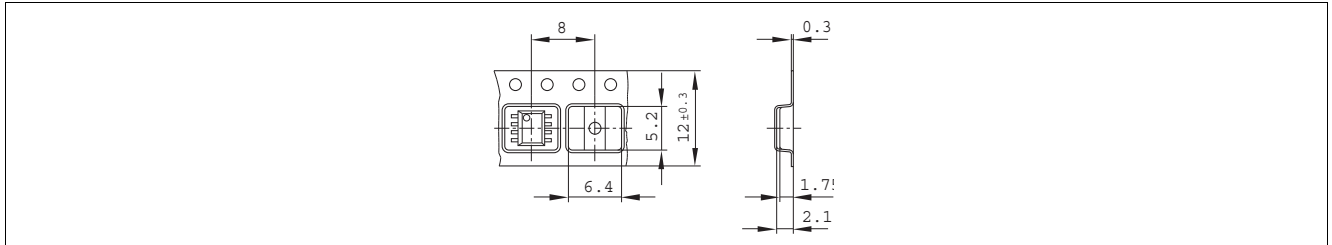

Figure 6-4 Tape and Reel

6.5 Marking

Position	Marking	Description
1st Line	012Bxxxx	See ordering table on Page 8
2nd Line	xxx	Lot code
3rd Line	Gxxxx	G..green, 4-digit..date code

Processing

Note: For processing recommendations, please refer to Infineon's Notes on processing

www.infineon.com

Published by Infineon Technologies AG