

LOW QUIESCENT CURRENT BACK TO BACK MOSFET DRIVER

Features

- Very low quiescent current on and off state
- Back to back configuration
- Boost converter with integrated diode
- Standard level gate voltage
- Input active high and 3.3V compatible
- Under voltage lockout with diagnostic
- Wide operating voltage 3-36V
- Ground loss protection
- Lead-Free, Halogen Free, RoHS compliant

Applications

- Power switch for Stop and Start board net stabilizer
- Battery switch

Product Summary

Operating voltage 3-36V
 Vgate 11.5V min.
 I Vcc average On 45µA max. at 25°C
 I Vcc average Off 35µA max. at 25°C

Package



SO8

Description

The AUIR3241S is a high side Mosfet driver for back to back topology targeting back to back switch. It features a very low quiescent current both on and off state. The AUIR3241S is a combination of a boost DC/DC converter using an external inductor and a gate driver. It drives standard level Mosfet even at low battery voltage. The input controls the gate voltage. The AUIR3241S integrates an under voltage lock out protection to prevent to drive the Mosfet in linear mode.

Ordering Information

Base Part Number	Package Type	Standard Pack		Complete Part Number
		Form	Quantity	
AUIR3241S	SOIC8	Tape and reel	2500	AUIR3241STR

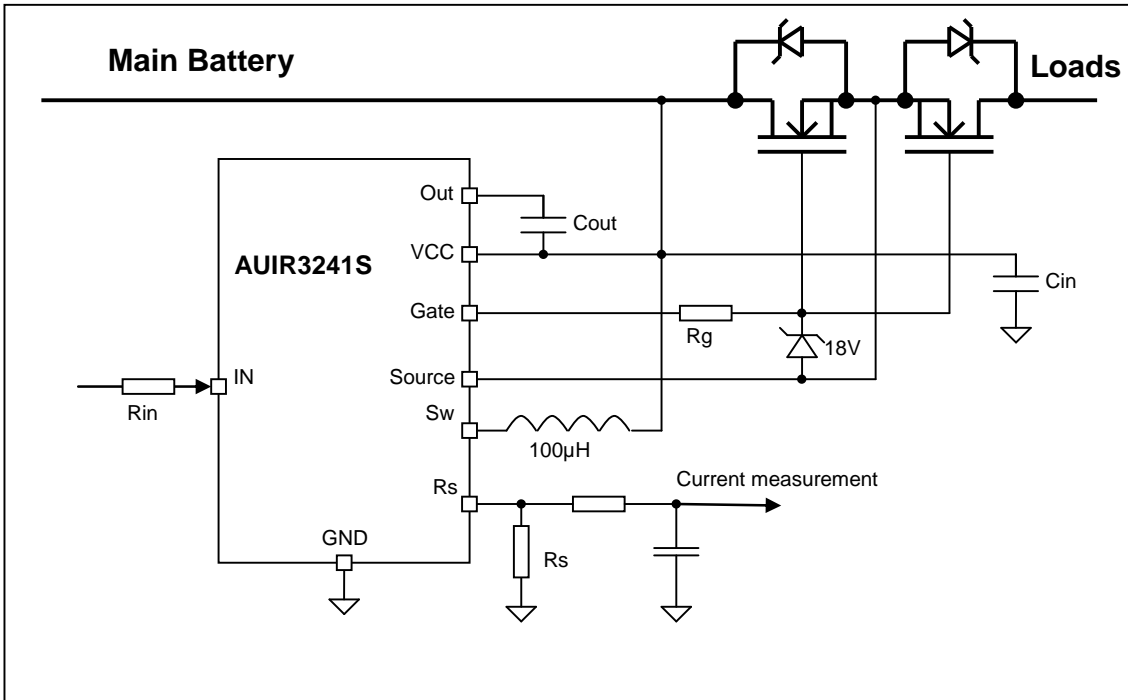
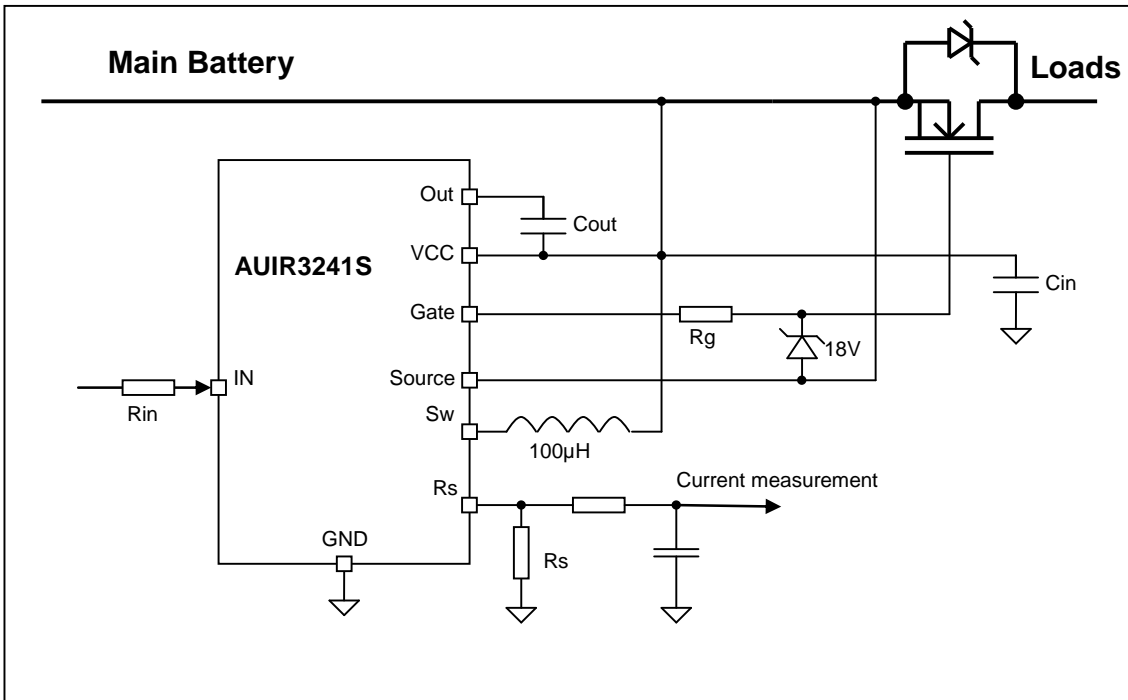
Typical Connection – Back to Back

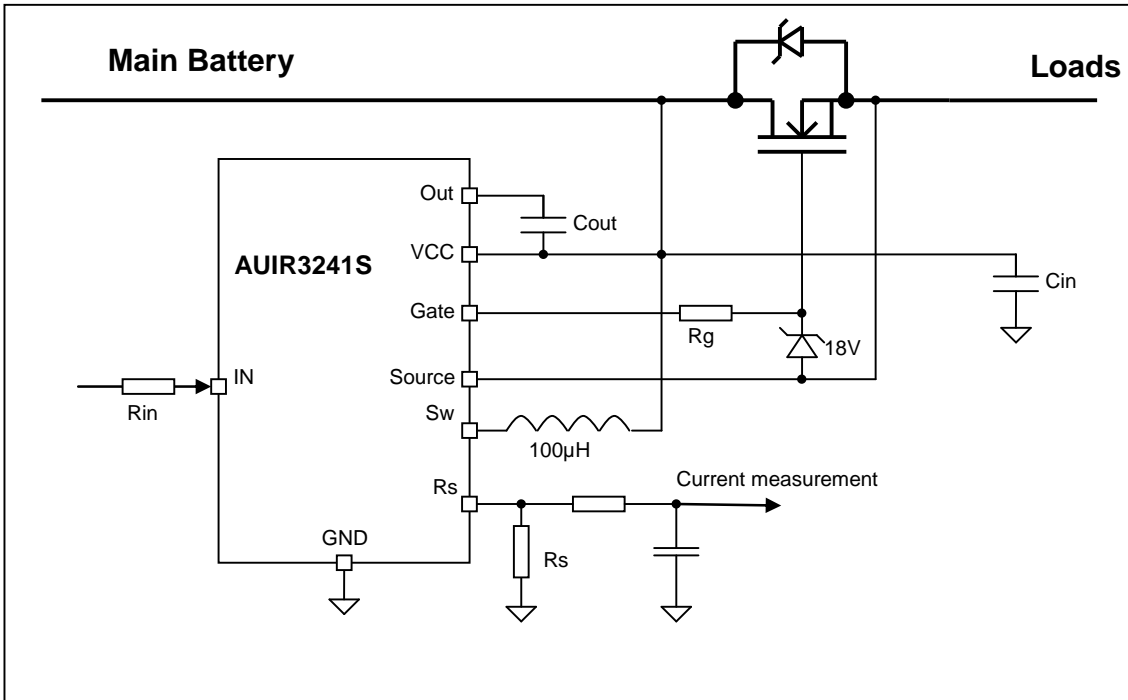
Typical Connection – Q_diode

Typical Connection – Battery switch

Absolute Maximum Ratings

Absolute maximum ratings indicate sustained limits beyond which damage to the device may occur.

Symbol	Parameter	Min.	Max.	Units
Vcc-gnd	Maximum Vcc voltage	-0.3	65	V
Vsw-gnd	Maximum Sw voltage	Vrs-0.3	Vout+Vf	
Vsw-Vrs	Maximum Sw voltage	-0.3	65	
Vout-Vcc	Maximum Vout-Vcc voltage	-0.3	65	
Vout-gnd	Maximum Vout voltage	-0.3	65	
Vout-Vgate	Maximum Vout-Vgate voltage	-0.3	65	
Vgate-Vsource	Maximum Vgate-Vsource voltage	-0.3	75	
Vout-Vsource	Maximum Vout-Vsource voltage	-0.3	75	
Vrs-gnd	Maximum Rs pin voltage	-0.3	6	
Vin-gnd	Maximum IN pin voltage	-0.3	Vout+0.3	
Isw	Maximum continuous current in Sw pin	—	200	mA
ID	Maximum continuous current in the rectifier diode	—	200	
Rg	Minimum gate resistor	100	—	Ohm
Tj max.	Maximum operating junction temperature	-40	150	°C
	Maximum storage temperature	-55	150	

Thermal Characteristics

Symbol	Parameter	Typ.	Max.	Units
Rth	Thermal resistance junction to ambient	100	—	°C/W

Recommended Operating Conditions

Symbol	Parameter	Min.	Max.	Units
VIH	High level input voltage	2.5	5.5	V
VIL	Low level input voltage	0	0.8	

Static Electrical Characteristics

T_j=-40..125°C, V_{cc}=6..16V (unless otherwise specified), typical value are given for V_{cc}=14V and T_j=25°C.

Symbol	Parameter	Min.	Typ.	Max.	Units	Test Conditions	
V _{cc op (ext).}	Supply voltage range for extended operation (some parameters may be downgraded beyond nominal operation)	3	—	36	V	See page 11	
V _{cc op (nom).} ⁽¹⁾	Supply voltage range for nominal operation	6	—	16			
I _{q Vcc Off} ⁽²⁾	Supply current when Off, T _j =25°C	—	2	6	µA	Vin=0V, K1/K2 off, K3 on, Vout-Vcc=14V	
	Supply current when Off, T _j =125°C	—	3	8			
I _{q Vcc On} ⁽²⁾	Supply current when On, T _j =25°C	—	3	6		µA	Vin=5V, K1/K3 off, K2 on, Vout-Vcc=14V
	Supply current when On, T _j =125°C	—	4	8			
I _{q Out Off} ⁽²⁾	Quiescent current on Out pin, T _j =25°C	—	10	15		Vin=0V, K1/K2 off, K3 on, Vout-Vcc=14V	
	Quiescent current on Out pin, T _j =125°C	—	13	25			
I _{q Out On} ⁽²⁾	Quiescent current on Out pin, T _j =25°C	—	12	20		Vin=5V, K1/K3 off, K2 on, Vout-Vcc=14V	
	Quiescent current on Out pin, T _j =125°C	—	15	30			
V _{br Out}	Breakdown voltage between Out and Source	75	90	—	V	I=10mA	
V _{br Gate}	Breakdown voltage between Gate and Source	75	90	—		I=10mA	
OV	Over-voltage protection between Vout and Gnd	50	55	62			
I _{in}	Input current	—	3	6	µA	Vin=5V	
V _{in_th}	Input voltage threshold	0.8	1.5	2.5	V		
V _{out_th}	Output voltage threshold	11.5	12.5	14			
UV_LO	Undervoltage lockout between Vout and Vcc	6.5	8	10		See figure 7	
V _{out_th} -UV_LO	Output voltage minus Undervoltage lockout threshold	3	4.5	—			
V _{rs th}	R _s threshold	0.8	1	1.3			
I _{latch UV_LO}	Under voltage lockout Latch current between Vout and Vcc	10	25	40	mA	See page 11	
V _f	Forward voltage of rectifier diode	—	0.9	1.1	V	I=100mA, T _j =25°C	
R _{dson K1}	R _{dson} of K1, T _j =-40°C	—	8	13	Ω	I=100mA, Vout-Vcc=12.5V	
	R _{dson} of K1, T _j =25°C	—	11	15			
	R _{dson} of K1, T _j =125°C	—	15	20			
R _{dson K2}	R _{dson} of K2, T _j =25°C	—	25	—		I=100mA	
R _{dson K3}	R _{dson} of K3, T _j =25°C	—	25	—			

⁽¹⁾ If the part is supply outside of this range (ex: during ramp up of V_{cc}), other values in this table might not be guaranteed

⁽²⁾ Supply current might be higher than specified during the start-up of the part (especially during the charge of Cout)

Timing Converter Characteristics

T_j=-40..125°C, V_{cc}=6..16V (unless otherwise specified), typical value are given for V_{cc}=14V and T_j=25°C.

Symbol	Parameter	Min.	Typ.	Max.	Units	Test Conditions
T _{off}	Off time	2	3	4	µs	See figure 4
T _{don K1}	Turn-on delay of K1	—	5	—		See figure 5
T _{doff K1}	Turn-off delay of K1	—	0.2	—		
POR_Delay	Power On Reset delay	200	500	1200		See figure 10
POR_Th	Power On Reset threshold	6	6.5	7.5	V	

Switching Characteristics

T_j=-40..125°C, V_{cc}=6..16V (unless otherwise specified), typical value are given for V_{cc}=14V and T_j=25°C.

Symbol	Parameter	Min.	Typ.	Max.	Units	Test Conditions
T _{don gate}	Turn-on delay	0.5	1.5	3	µs	
T _{r gate}	Rise time on gate 10% to 90% of Vout-Vcc	—	6	15		C _{gate} =100nF
I _{gate+}	Gate high short circuit pulsed current	100	350	—	mA	V _{gate} -V _{source} =0V
T _{doff gate}	Turn-off delay	0.5	2	5	µs	
T _{f gate}	Fall time on gate 90% to 10% of Vout-Vcc	—	6	15		C _{gate} =100nF
I _{gate-}	Gate low short circuit pulsed current	100	350	—	mA	V _{gate} -V _{source} =14V
T _{reset}	Time to reset the under voltage latches	—	1	100	µs	See page 11

Lead Definitions

Pin number	Symbol	Description
1	IN	Input pin
2	GND	Ground pin
3	RS	Current sense input pin
4	SW	Output of K1
5	Source	Connection of the source pin of the Mosfets
6	Gate	Output of the gate driver
7	Vcc	Power supply
8	Out	Output of the boost converter

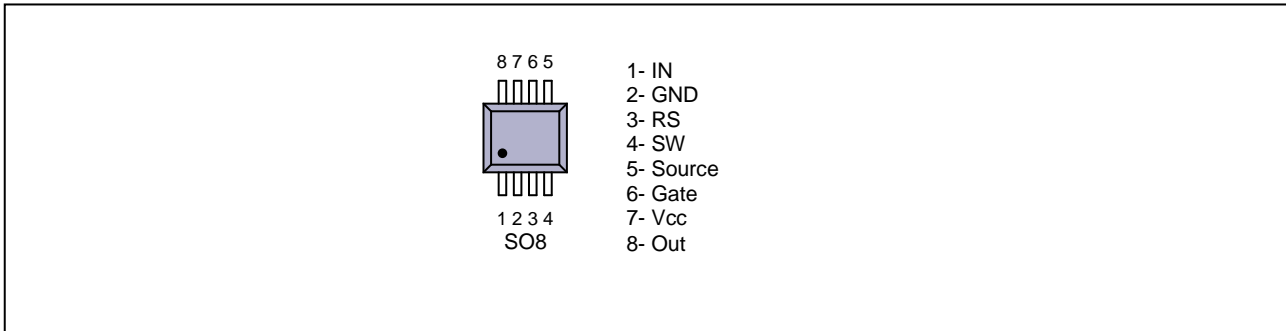
Lead Assignments

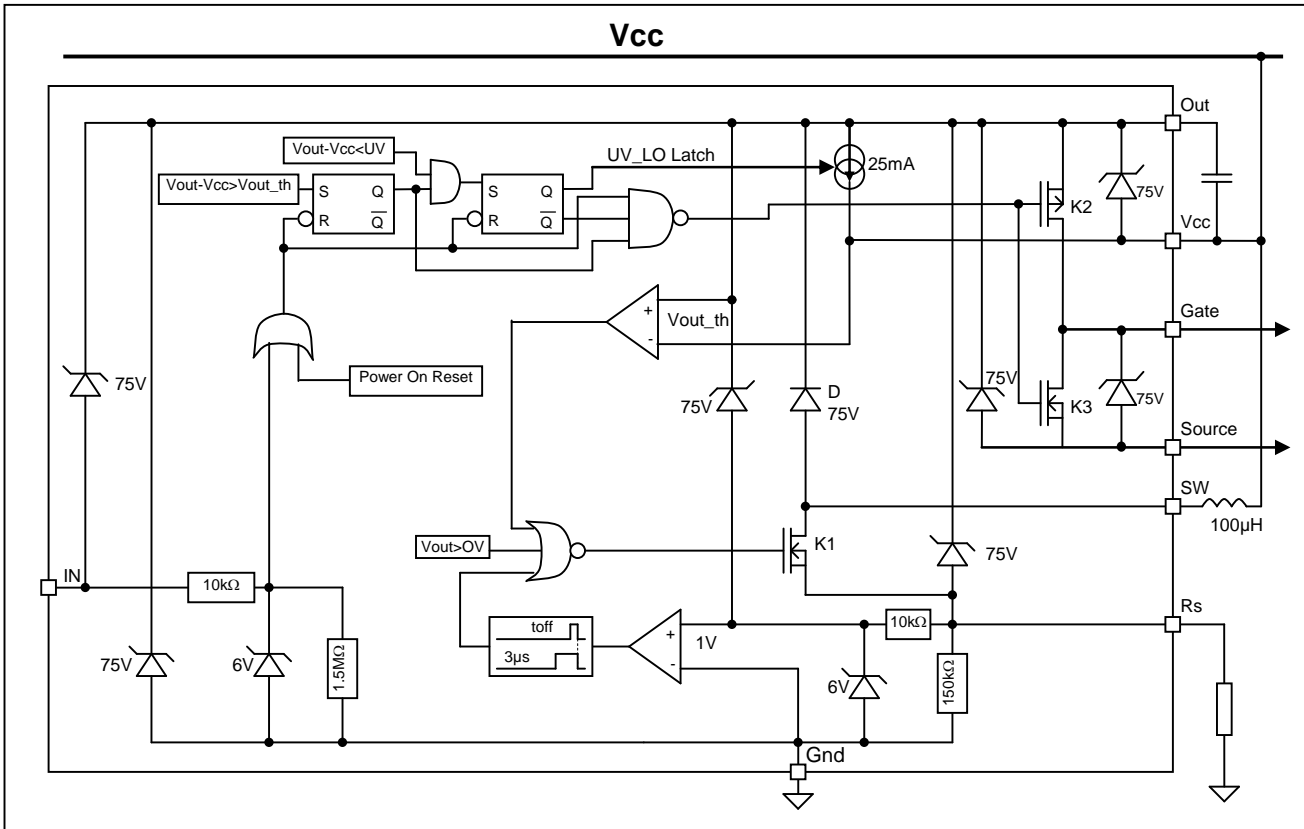
Block diagram

Input Circuitry

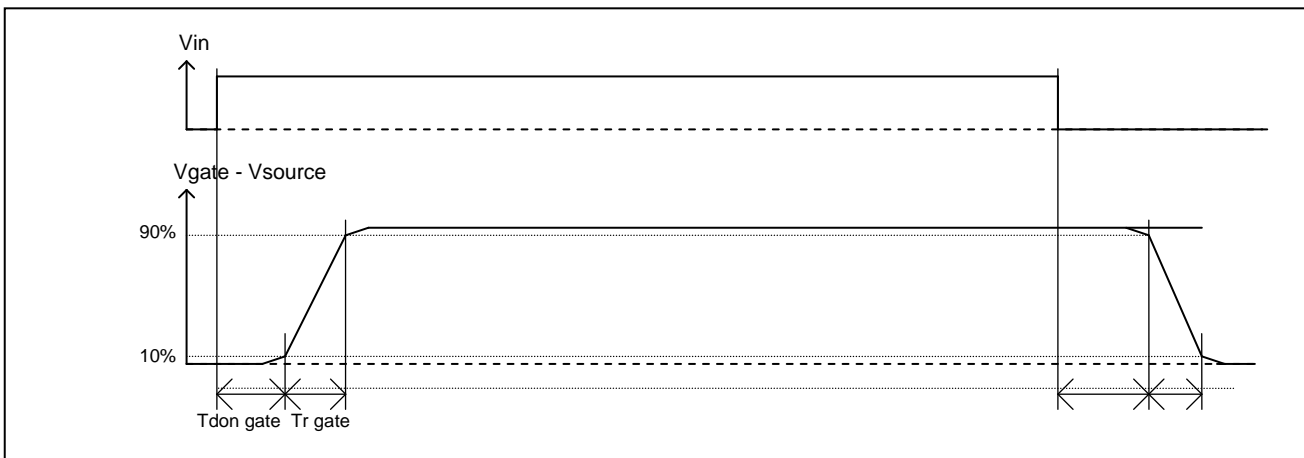
The input control circuitry drives the output gate driver stage. The input is active high. With a low level input voltage, the gate is shorted to the source. With a high level input, the output gate driver turn on when V_{out} reaches V_{out_th} .

Figure 1

Description

The topology of the AUIR3241S is a boost DC/DC converter working in current mode. The DC/DC is working once the AUIR3241S is powered regardless the input level.

K1 is switched on when the gate voltage is lower than V_{out} threshold. When R_s pin reaches $V_{rs\ th}$, K1 is turned off and the inductor charges the Out capacitor through D. The system cannot restart during T_{off} after $V_{rs\ th}$ has been reached. The DC/DC restart only when the Out and the Vcc voltage difference is lower than V_{out_th} in order to achieve low quiescent current on the power supply.

To turn off the power Mosfet, the input must be low. Then K2 is turned off and K3 shorts the gate to the source.

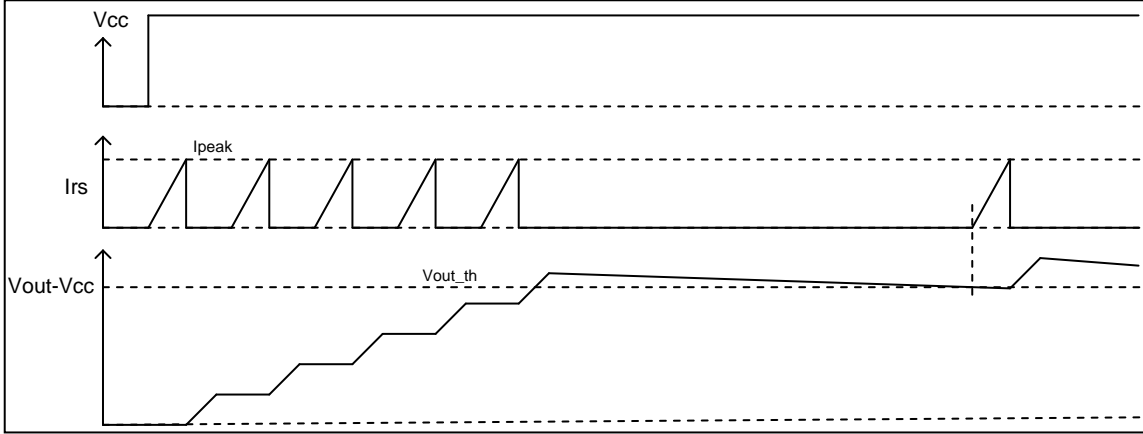

Figure 2

Parameters definition

Current definition

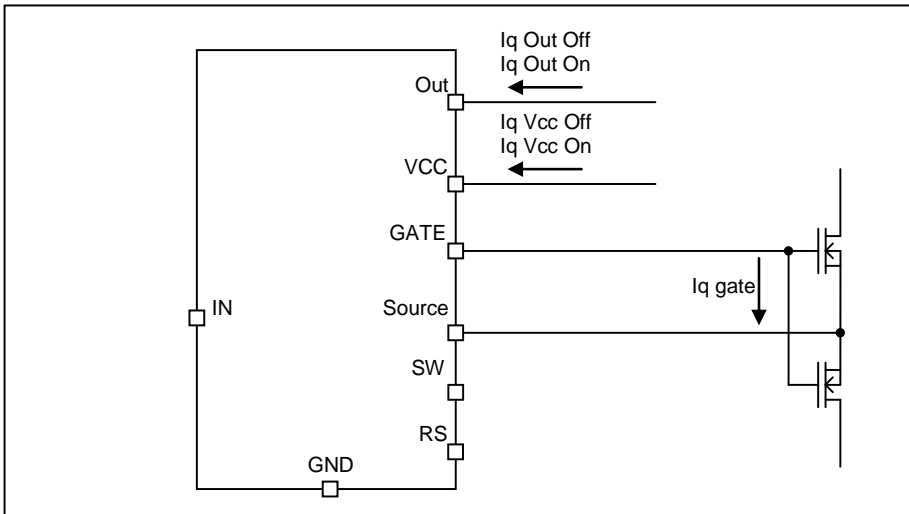
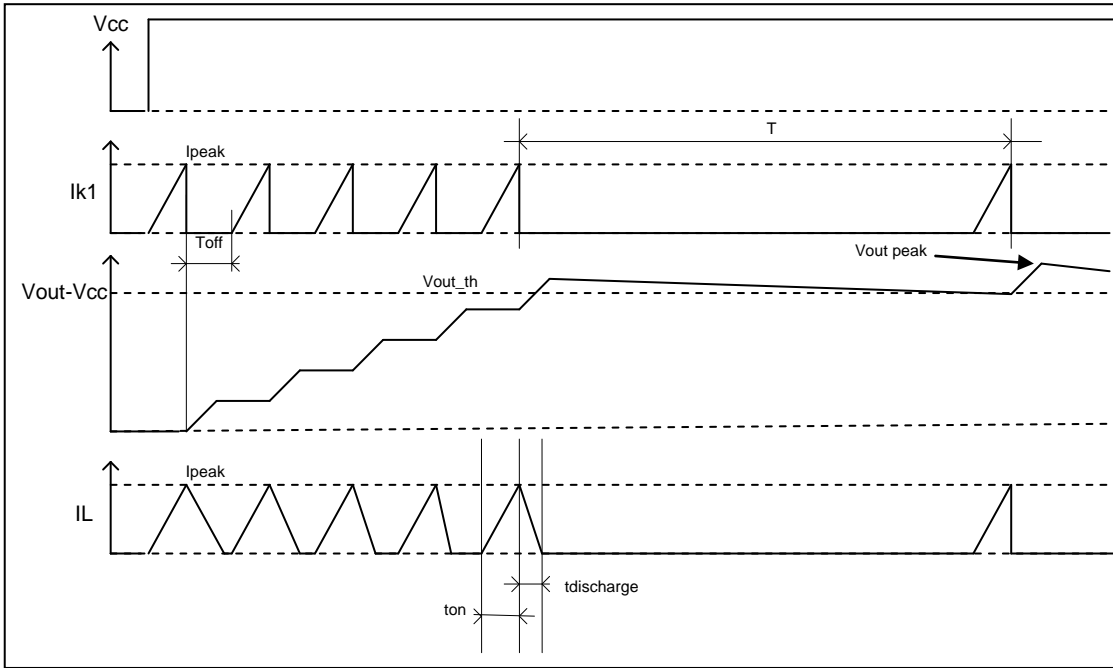
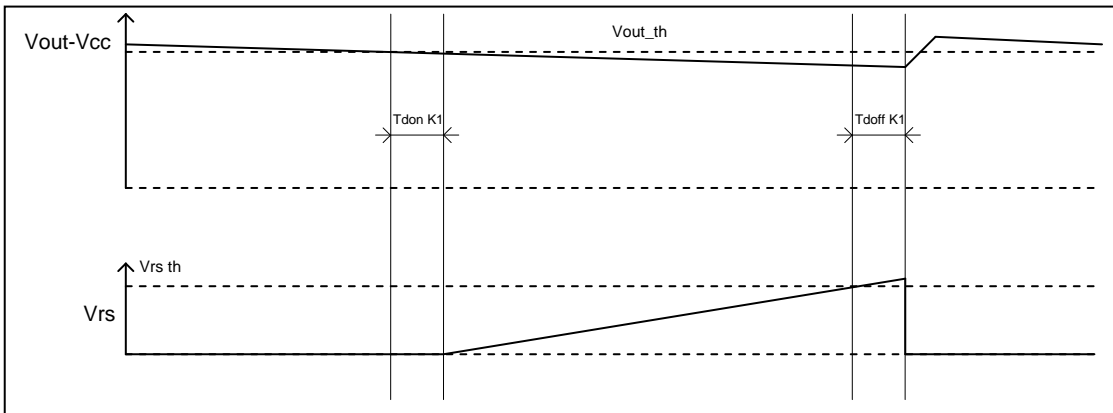

Figure 3

Timing definition

Figure 4

Figure 5
Low quiescent current operation when On.

The AUIR3241S is able to operate with a very low quiescent current on the Vcc pin. Nevertheless the supply current depends also on the leakage of the power mosfet named "Iq gate" on the diagram below.

The leakage current is given when K1 is off. When K1 is on, the current flowing in Vcc is the current charging the inductor. Therefore the average current on the Vcc is the combination of the current when K1 is ON and OFF. The average current on the Vcc pin can be calculated using:

$$I_{Vcc \text{ average on}} = (I_{q \text{ gate}} + I_{q \text{ Out On}}) * \frac{V_{out} - V_{cc} + V_f}{V_{cc}} + I_{q \text{ Vcc on}} + I_{q \text{ Out on}}$$

$$I_{Vcc \text{ average off}} = (I_{q \text{ gate}} + I_{q \text{ Out Off}}) * \frac{V_{out} - V_{cc} + V_f}{V_{cc}} + I_{q \text{ Vcc off}} + I_{q \text{ Out off}}$$

With Vout: the average voltage on the output.

$$V_{out \text{ average}} = (V_{out \text{ peak}} + V_{out \text{ th}}) / 2$$

Vout peak can be calculated by:

$$V_{out \text{ peak}} = \sqrt{\frac{L}{C_{out}} \cdot I_{peak}^2 + V_{out \text{ th}}^2}$$

During On operation, the DC/DC works in pulse mode, meaning each time the $V_{out}-V_{cc}$ voltage comes below 12.5V, the AUIR3241S switches on K1 to recharge the gate voltage. When the I_{out} leakage is low enough to maintain the DC/DC in discontinuous mode, the frequency is calculate by:

$$T = \frac{I_{peak}^2 * L}{2 * (I_{q \text{ gate}} + I_{q \text{ Vout on}}) * (V_{out} - V_{cc} + V_f)}$$

Peak current control

The current in the inductor is limited by the 1V comparator which monitors the voltage across R_s . Due to the delay in the loop ($t_{doff K1}$), the inductor current will exceed the threshold set by: $\frac{V_{rsth}}{R_s}$

At low voltage, the current waveform in the inductor is not anymore linear, but exponential because the sum of the resistor of K1, the inductor and R_s are not any more negligible.

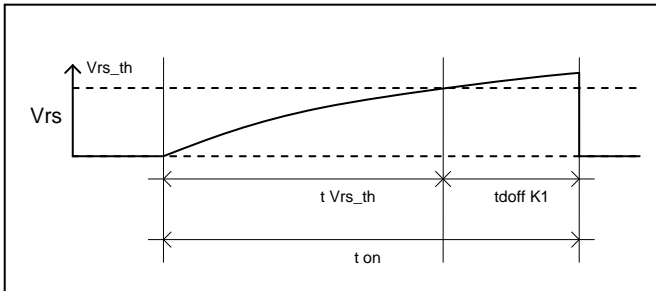

Figure 6

The peak current and t_{on} can be calculated as follow:

$$t_{Vrs_{th}} = - \frac{L}{R_{don k1} + R_s + R_l} * \ln \left(1 - \frac{R_s + R_{dson k1} + R_l}{V_{rs_{th}} * R_s * V_{cc}} \right)$$

Where R_l is the resistor of the inductor

With : $t_{on} = t_{Vrs_{th}} + t_{doff K1}$

The peak current can be solved by:

$$I_{peak} = \frac{V_{cc}}{R_{dson k1} + R_s + R_l} * \left(1 - e^{-t_{on} * \frac{R_{dson k1} + R_s + R_l}{L}} \right)$$

The peak current must not exceed the Maximum Rating of I_{sw} .

Output capacitor choice

The output capacitor must be chosen based on 2 criteria:

- During the turn on of K2, the voltage drop on Cout must not trigger the Under Voltage Lockout due to the gate charge of the Power Mosfet.

$$C_{out} > \frac{Q_{\text{gate total Power Mosfet}}}{(V_{out_{th}} - UV_{LO})_{\text{Min.}}}$$

- When K1 turn off and the inductor is charging Cout, the peak current on the output capacitor must be limited in order to avoid having current flowing in the Gate zener diode:

$$C_{out} > \frac{L * I_{\text{peak}}^2_{\text{max}}}{V_{z \text{ min gate}}^2 - V_{out \text{ th max}}^2}$$

Vz min gate is the minimum Zener voltage of the external gate Zener diode.

Minimum operating voltage

While the AUIR3241S operating voltage is specified between 3V and 36V. The 3V minimum operating voltage is when the Vcc is going down. The minimum voltage is also limited by the fact that the Rs voltage must reach the Vrsth taking account all resistors which limit the inductor current.

$$V_{cc \text{ min}} = \frac{R_{dson \text{ k1}} + R_s + R_l}{R_s} * V_{rsth}$$

Over-Voltage protection

The AUIR3241S integrates an over-voltage protection in order to protect K1. When Vcc exceed the Over-voltage threshold, the DC/DC is stopped.

Under voltage lockout - Diagnostic

In order to avoid to drive the Power Mosfet in linear mode, the AUIR3241S features an under voltage lockout. During the turn on, the gate will not be powered until Vout-Vcc reaches Vout th, meaning K2 is off and K3 is on. Then the AUIR3241S powers the gate of the mosfet. If Vout-Vcc goes below UV_LO, the gate is shorted to the source and the part is latched. A cycle in the input is required to reset the latch. The input must be kept low longer than Treset.

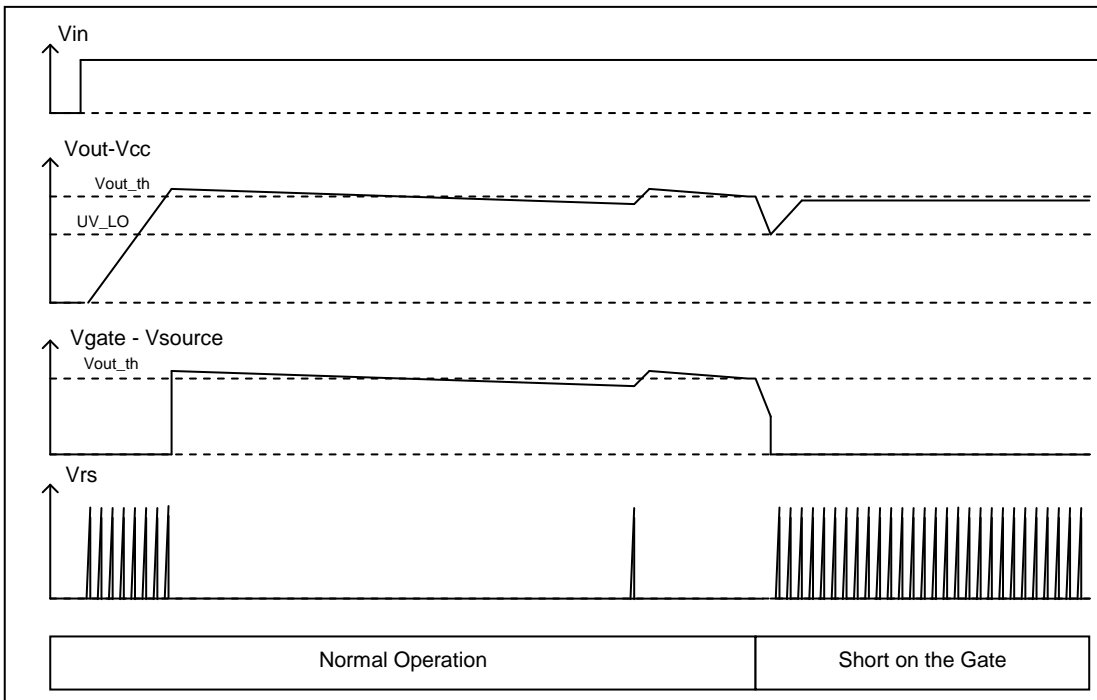
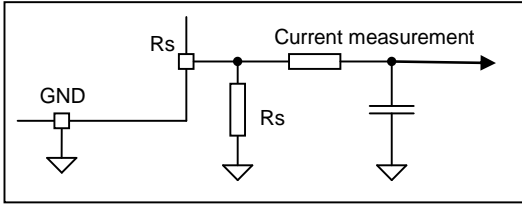

Figure 7

When the part is latched a current source (I latch UV_LO) is connected between Out and Vcc to increase the current consumption. By monitoring the current consumption the system can have a diagnostic of the output status. The diagnostic can be analog or digital.

Analog Diagnostic: Output current measurement

The average current into R_s can be measured by adding a low pass filter before the ADC of the micro controller.

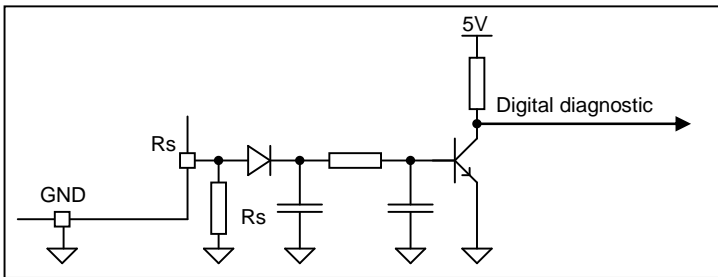

Figure 8

Then the average output current can be evaluated using :
 $I_{out\ av} = I_{Rs\ av} * V_{cc} / (V_{out} - V_{cc})$

Knowing the output current can be useful to do a diagnostic on the power Mosfet. If the gate is shorted, the output current will be significantly higher than in normal operation.

Digital diagnostic

By adding a diode during high current consumption mode, the output voltage can be close to 1V. Using a bipolar with a pull-up resistor will provide a digital diagnostic.

Figure 9
Power On Reset

During the power on, the AUIR3241S features a Power On Reset to guarantee a stable state of the 2 latches of the Under voltage lockout and guarantee a stable internal biasing. POR_Delay is triggered when $V_{out-Gnd}$ exceeds POR_Th .

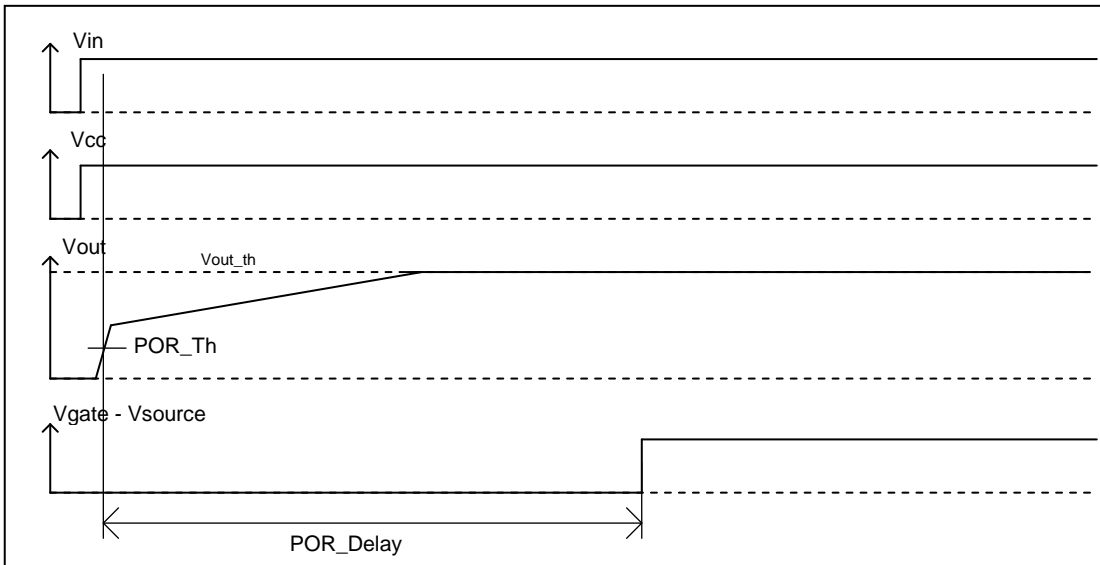
Figure 10

Figures are given for typical value, Vcc=14V and Tj=25°C otherwise specified

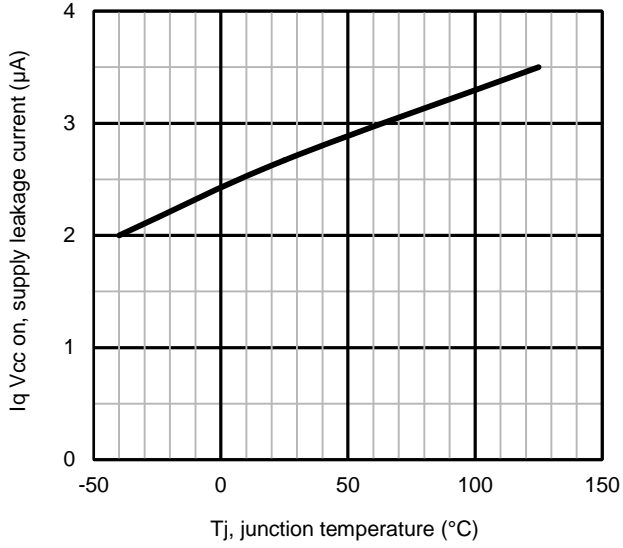

Figure 11 – Iq Vcc on (μA) Vs Tj (°C)

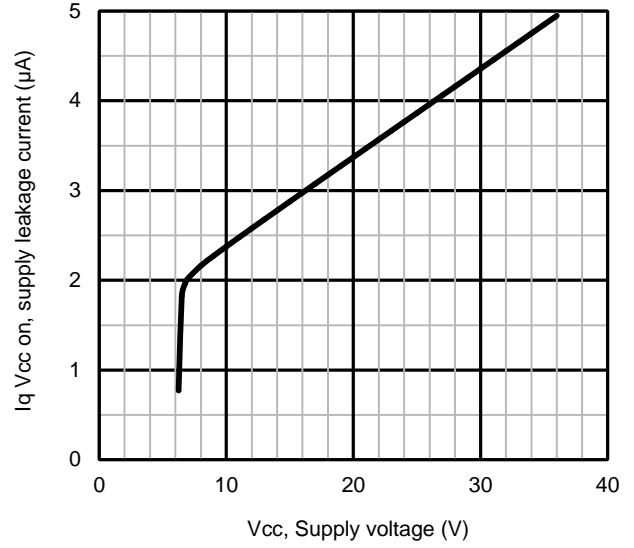

Figure 12 – Iq Vcc on (μA) Vs Vcc(V)

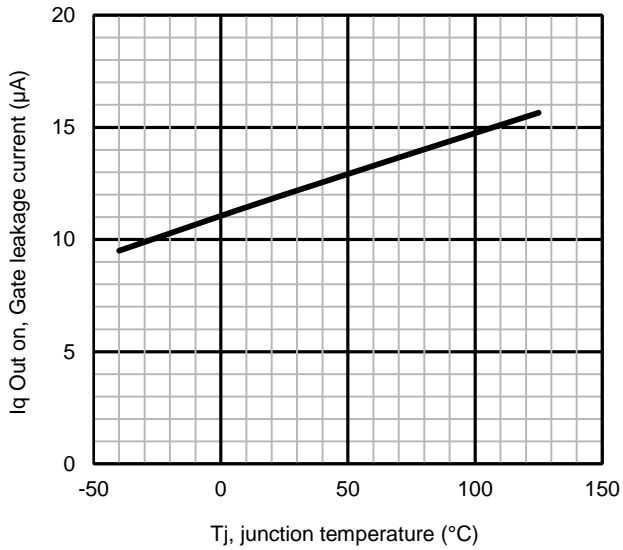

Figure 13 – Iq Out on (μA) Vs Tj (°C)

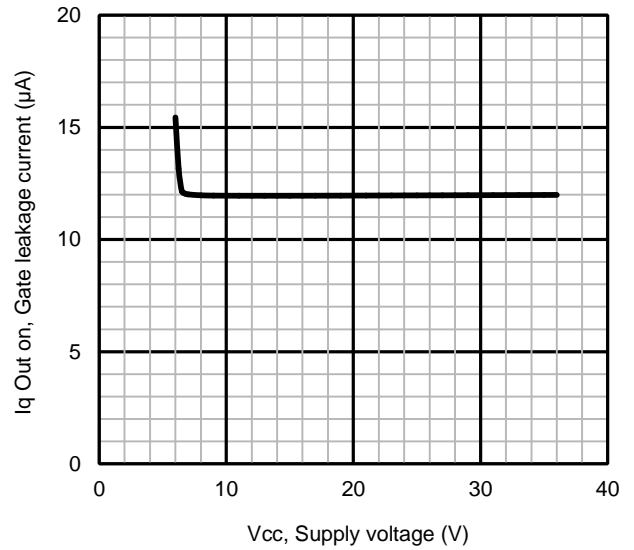

Figure 14 – Iq Out on (μA) Vs Vcc(V)

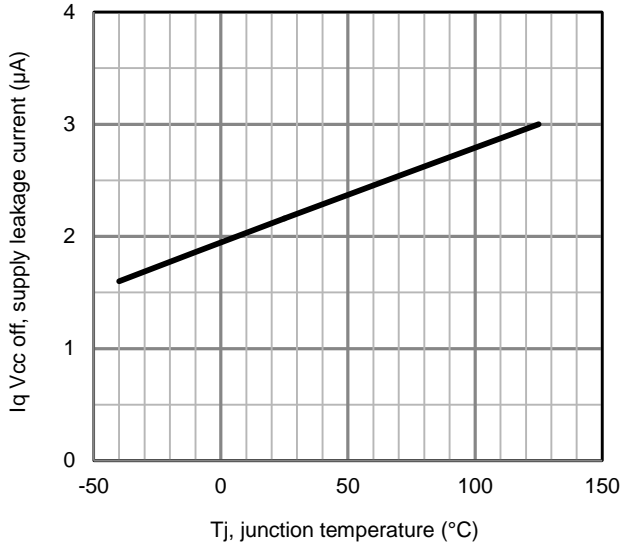

Figure 15 – Iq Vcc off (µA) Vs Tj (°C)

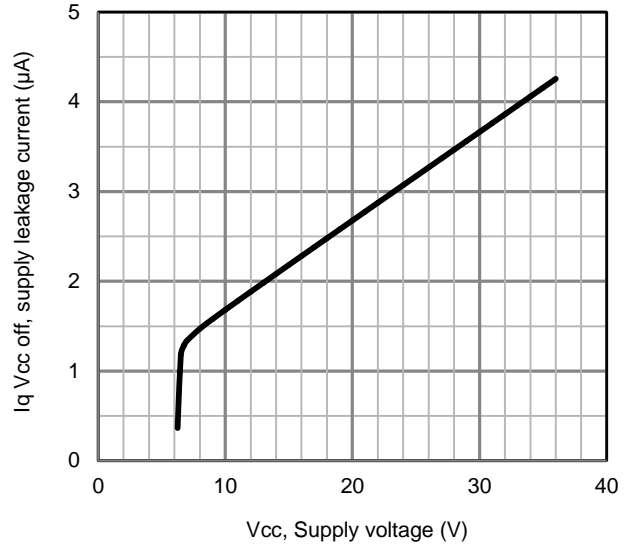

Figure 16 – Iq Vcc off (µA) Vs Vcc(V)

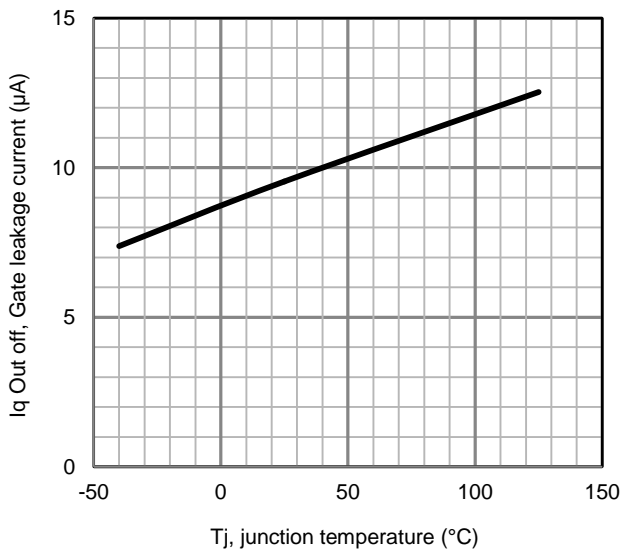

Figure 17 – Iq Out off (µA) Vs Tj (°C)

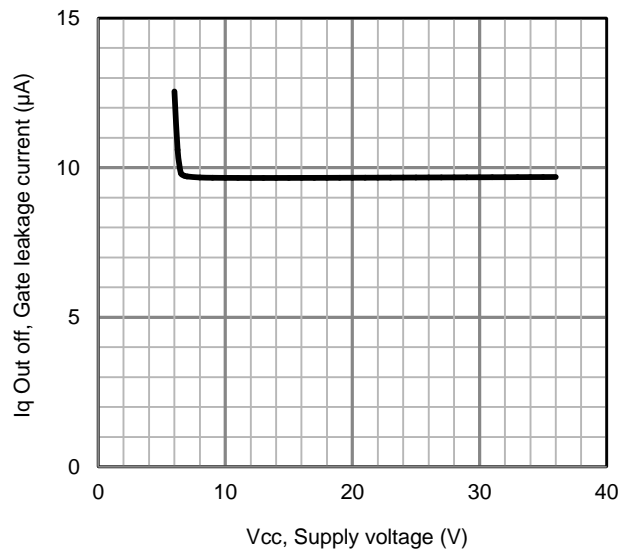
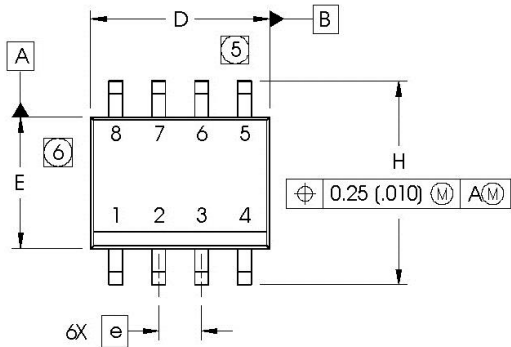

Figure 18 – Iq Out off (µA) Vs Vcc(V)

Case Outline – SO8

Dimensions are shown in millimeters (inches)

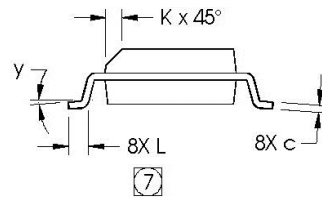
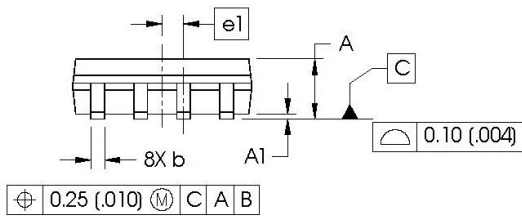

DIM	INCHES		MILLIMETERS	
	MIN	MAX	MIN	MAX
A	.0532	.0688	1.35	1.75
A1	.0040	.0098	0.10	0.25
b	.013	.020	0.33	0.51
c	.0075	.0098	0.19	0.25
D	.189	.1968	4.80	5.00
E	.1497	.1574	3.80	4.00
e	.050 BASIC		1.27 BASIC	
e1	.025 BASIC		0.635 BASIC	
H	.2284	.2440	5.80	6.20
K	.0099	.0196	0.25	0.50
L	.016	.050	0.40	1.27
y	0°	8°	0°	8°

NOTES:

1. DIMENSIONING & TOLERANCING PER ASME Y14.5M-1994.
2. CONTROLLING DIMENSION: MILLIMETER
3. DIMENSIONS ARE SHOWN IN MILLIMETERS (INCHES).
4. OUTLINE CONFORMS TO JEDEC OUTLINE MS-012AA.
5. DIMENSION DOES NOT INCLUDE MOLD PROTRUSIONS. MOLD PROTRUSIONS NOT TO EXCEED 0.15 (.006).
6. DIMENSION DOES NOT INCLUDE MOLD PROTRUSIONS. MOLD PROTRUSIONS NOT TO EXCEED 0.25 (.010).
7. DIMENSION IS THE LENGTH OF LEAD FOR SOLDERING TO A SUBSTRATE.

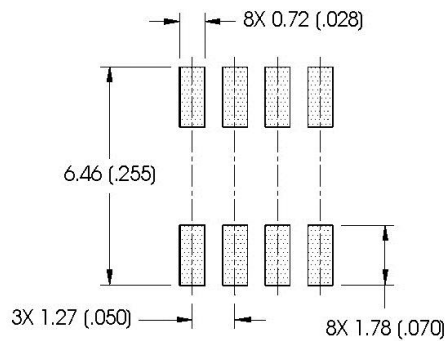
FOOTPRINT

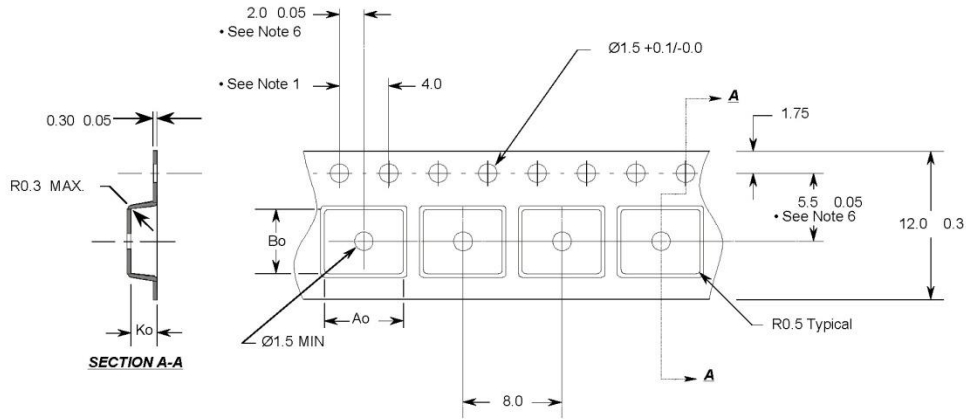
Tape & Reel SO8

Notes:

1. 10 sprocket hole pitch cumulative tolerance: 0.2
2. Camber not to exceed 1mm in 100mm
3. Material: Black Conductive Advantek Polystyrene
4. A_o and B_o measured on a plane 0.3mm above the bottom of the pocket
5. K_o measured from a plane on the inside bottom of the pocket to the top surface of the carrier.
6. Pocket position relative to sprocket hole measured as true position of pocket, not pocket hole.

$A_o = 6.4$ mm
 $B_o = 5.2$ mm
 $K_o = 2.1$ mm

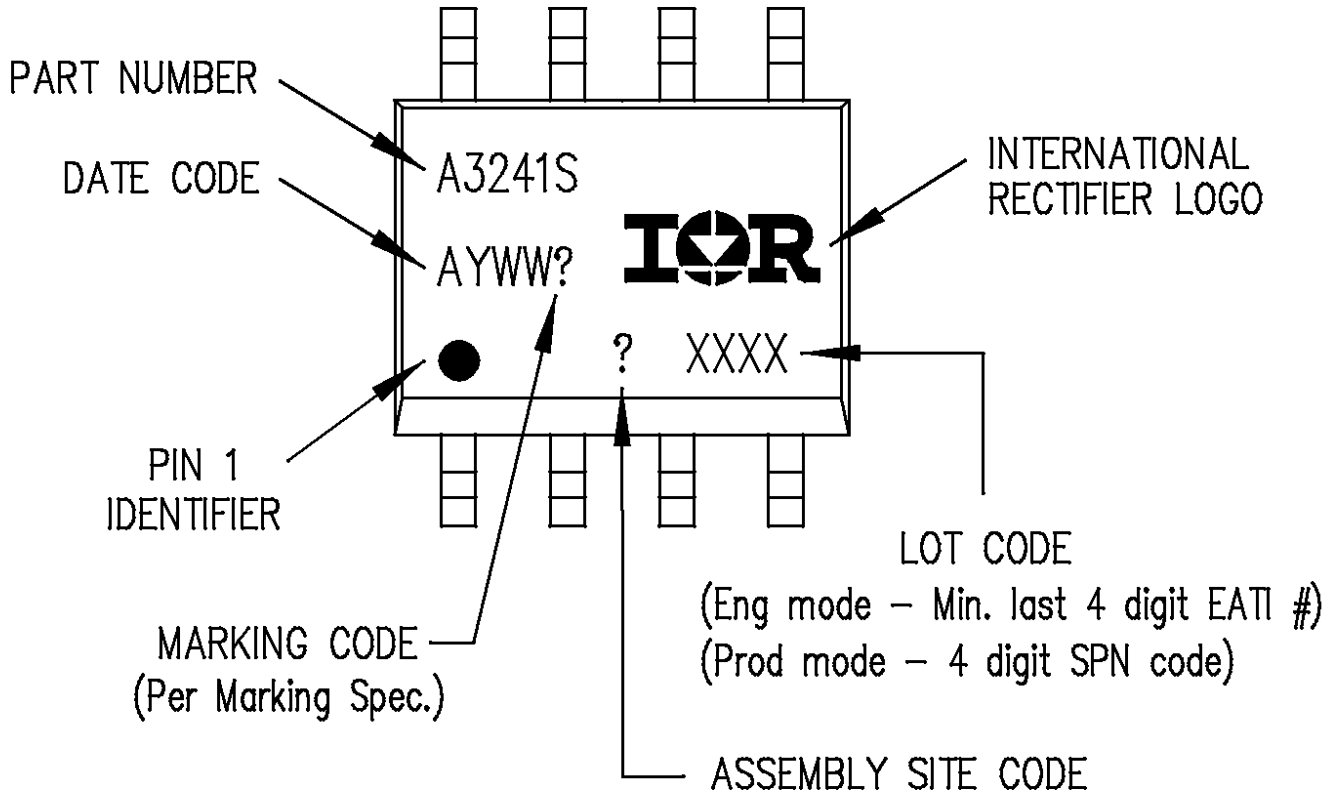
- All Dimensions in Millimeters -

Part Marking Information

TOP MARKING (LASER)
Qualification Information

Qualification Level		Automotive (per AEC-Q100)
		Comments: This family of ICs has passed an Automotive qualification. IR's Industrial and Consumer qualification level is granted by extension of the higher Automotive level.
Moisture Sensitivity Level		SOIC-8L MSL2, 260°C (per IPC/JEDEC J-STD-020)
ESD	Human Body Model	Class 1C Passed 1500V (per AEC-Q100-002)
	Charged Device Model	Class C6 (+/-1000V) (per AEC-Q100-011)
IC Latch-Up Test		Class II Level A (per AEC-Q100-004)
RoHS Compliant		Yes

Published by
Infineon Technologies AG
81726 München, Germany
© Infineon Technologies AG 2015
All Rights Reserved.

IMPORTANT NOTICE

The information given in this document shall in no event be regarded as a guarantee of conditions or characteristics ("Beschaffenheitsgarantie"). With respect to any examples, hints or any typical values stated herein and/or any information regarding the application of the product, Infineon Technologies hereby disclaims any and all warranties and liabilities of any kind, including without limitation warranties of non-infringement of intellectual property rights of any third party.

In addition, any information given in this document is subject to customer's compliance with its obligations stated in this document and any applicable legal requirements, norms and standards concerning customer's products and any use of the product of Infineon Technologies in customer's applications.

The data contained in this document is exclusively intended for technically trained staff. It is the responsibility of customer's technical departments to evaluate the suitability of the product for the intended application and the completeness of the product information given in this document with respect to such application.

For further information on the product, technology, delivery terms and conditions and prices please contact your nearest Infineon Technologies office (www.infineon.com).

WARNINGS

Due to technical requirements products may contain dangerous substances. For information on the types in question please contact your nearest Infineon Technologies office.

Except as otherwise explicitly approved by Infineon Technologies in a written document signed by authorized representatives of Infineon Technologies, Infineon Technologies' products may not be used in any applications where a failure of the product or any consequences of the use thereof can reasonably be expected to result in personal injury.

Revision History

Revision	Date	Notes/Changes
Rev 1.0	2017-04-27	Data Sheet created.
Rev 1.01	2017-09-12	Update drawing, Differentiate Vcc_op (ext) & Vcc_op (nom), add Appendixes (1) & (2) on Page 5