

High-Performance, High-Current DrMOS Power Module

Features

- 4.5V ~ 5.5V Input Range for VCC & PVCC
- 4.5V ~ 25V Input Range for VIN
- Power-On-Reset Monitoring on VCC Pin
- APW8703-Up to 10A (peak), 8A (continuous) output current scale
- APW8706-Up to 8A (peak), 6A (continuous) output current scale
- APW8707-Up to 25A (peak), 13A (continuous) output current scale
- Adjustable Over-Current Protection Threshold
- Up to 1.5MHz PWM operation
- Built-in Tri-State PWM input Function
- Built in EN Timing Control function
- Build in N-CH MOSFET for high side, N-CH MOSFET for low side
- Skip Mode Operation
- Over-Temperature Protection
- TQFN 4x4-23P package and TQFN 5x5-30 packages
- Lead Free and Green Devices Available (RoHS Compliant)

General Description

The APW8703/6/7 integrates a high-side N-channel MOSFET and a low-side N-channel MOSFET with adaptive dead-time control. The APW8703/6/7 have a built-in tri-state PWM input function which can support a number of PWM controllers. When the PWM input signal stays tri-state, the tri-state function shuts off the high-side MOSFET and turns on the low-side MOSFET without consider ZC function. The device is also equipped with Power-On-Reset (POR) and enable control functions into a single package and accurate current limit. The device over-current protection monitors the output current by using the voltage drop across the $R_{DS(ON)}$ of low-side MOSFET, eliminating the need for a current sensing resistor that features high efficiency and low cost. The POR circuit with hysteresis monitors VCC supply voltage to start up/shut-down the IC at power-on/off. The APW8703/6/7 also can be enabled or disabled by other power system. Pulling the EN pin high or low will turn on or shut off the device.

Applications

- Desktops
- Graphics Cards
- Servers
- Portable/Notebook Regulators

Simplified Application Circuit

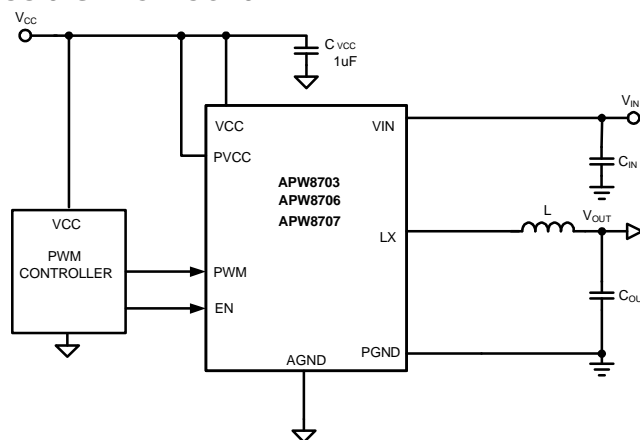

ANPEC reserves the right to make changes to improve reliability or manufacturability without notice, and advise customers to obtain the latest version of relevant information to verify before placing orders.

Ordering and Marking Information

<p>APW8703 </p> <p>APW8706</p> <p>APW8707</p> <p>Assembly Material</p> <p>Handling Code</p> <p>Temperature Range</p> <p>Package Code</p>	<p>Package Code</p> <p>QB : TQFN 4x4-23 QB : TQFN 5x5-30</p> <p>Operating Ambient Temperature Range</p> <p>I : -40 to 85°C</p> <p>Handling Code</p> <p>TR : Tape & Reel</p> <p>Assembly Material</p> <p>G : Halogen and Lead Free Device</p>
<p>APW8703 QB: </p> <p>X - Date Code</p>	<p>APW8707 QB: </p> <p>X - Date Code</p>
<p>APW8706 QB: </p> <p>X - Date Code</p>	

Note: ANPEC lead-free products contain molding compounds/die attach materials and 100% matte tin plate termination finish; which are fully compliant with RoHS. ANPEC lead-free products meet or exceed the lead-free requirements of IPC/JEDEC J-STD-020D for MSL classification at lead-free peak reflow temperature. ANPEC defines "Green" to mean lead-free (RoHS compliant) and halogen free (Br or Cl does not exceed 900ppm by weight in homogeneous material and total of Br and Cl does not exceed 1500ppm by weight).

Pin Configuration

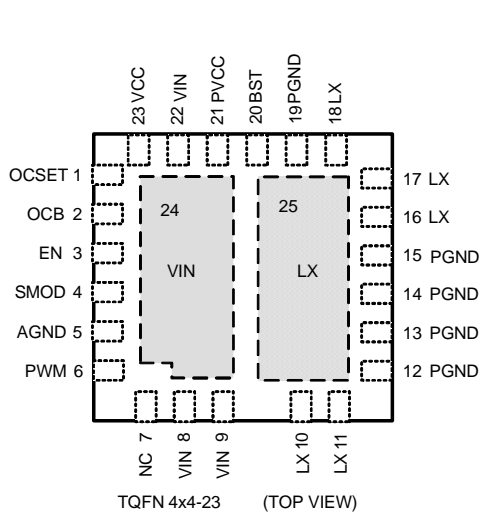

= Exposed and Thermal Pad

APW8703/6

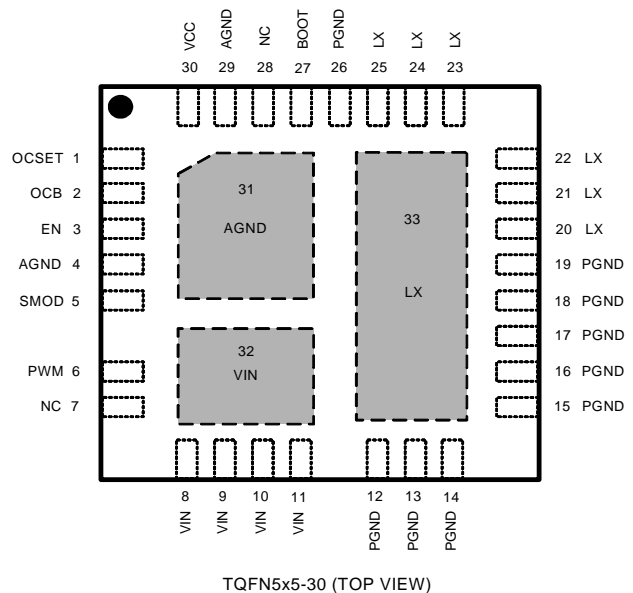

= Exposed and Thermal Pad

APW8707

Absolute Maximum Ratings (Note 1)

Symbol	Parameter	Rating	Unit
V_{CC} & V_{PVCC}	VCC & PVCC to GND Voltage	-0.3 ~ 7	V
V_{IN}	VIN to PGND Voltage	-0.3 ~ 30	V
V_{LX}	LX to PGND Voltage	>20ns Pulse Width	-0.3 ~ 30
		<20ns Pulse Width	-5 ~ 38
V_{BST}	BST to GND Voltage	-0.3 ~ 37	V
$V_{BST-V_{LX}}$	BST to LX Voltage	-0.3 ~ 7	V
Other Pins	EN, SMOD, OCSET and PWM to AGND Voltage	-0.3 ~ $V_{CC}+0.3$	V
	AGND to PGND Voltage	-0.3 ~ 0.3	V
T_J	Junction Temperature	150	°C
T_{STG}	Storage Temperature	-65 ~ 150	°C
T_{SDR}	Maximum Lead Soldering Temperature(10 Seconds)	300	°C

Note1: Stresses beyond those listed under “absolute maximum ratings” may cause permanent damage to the device. These are stress ratings only and functional operation of the device at these or any other conditions beyond those indicated under “recommended operating conditions” is not implied. Exposure to absolute maximum rating conditions for extended periods may affect device reliability.

Thermal Characteristics

Symbol	Parameter	Typical Value	Unit
θ_{JA}	Junction-to-Ambient Resistance in free air ^(Note 2)	TQFN4x4-23	50
		TQFN5x5-30	25

Note 2: θ_{JA} is measured with the component mounted on a high effective thermal conductivity test board in free air.

Recommended Operating Conditions (Note 3)

Symbol	Parameter	Range	Unit
V_{CC} & P_{VCC}	VCC and PVCC to AGND Voltage	4.5 ~ 5.5	V
V_N	VIN to PGND Voltage	4.5 ~ 25	V
I_{OUT}	Maximum Continuous Output Current	APW8703	8
		APW8706	6
		APW8707	13
	Maximum Peak Output Current	APW8703	10
		APW8706	8
APW8707	25		
F_{PWM}	PWM Operation Frequency	0.1 ~ 1.5	MHz
T_A	Ambient Temperature	-40 ~ 85	°C
T_J	Junction Temperature	-40 ~ 125	°C

Note 3: Refer to the typical application circuit.

Electrical Characteristics

Unless otherwise specified, these specifications apply over $V_{CC} = V_{PVCC} = V_{EN} = 5V$, $V_{IN} = 12V$ and $T_A = 25^\circ C$.

	Parameter	Test Conditions	APW8703/6/7			Unit
			Min	Typ	Max	
SUPPLY CURRENT						
I_{VCC}	VCC Supply Current	EN = High, PWM = High, SMOD=L	-	90	120	μA
		EN = High, PWM = Low, SMOD=L	-	60	90	μA
		EN = Low	-	-	1.0	μA
POWER-ON-RESET(POR)						
	VCC Rising POR Thresold		3.7	4.0	4.3	V
	VCC POR Hysteresis		50	100	150	mV
POWER STAGE						
R_{ON_H}	High-side switch on resistance	APW8703	-	25	-	m Ω
		APW8706	-	30	-	
		APW8707	-	9.7	-	
R_{ON_L}	Low-side switch on resistance	APW8703	-	7	-	m Ω
		APW8706	-	12	-	
		APW8707	-	5.2	-	
I_{LX}	LX Leakage Current	$V_{IN} = V_{CC} = LX = 25V$, EN = GND	-1	-	1	μA
	VIN Pin Leakage Current	EN = Low, $V_{IN} = 25V$	-	-	1	μA
	BOOT Pin Current	$V_{BOOT-PGND} = 30V$, $V_{LX} = 25V$	-	-	1	μA
ZERO CURRENT DETECT						
V_{ZC}	Zero Current Detect	$V_{LX} - PGND$	-5	-	5	mV
Over-Current Protection(OCP)						
I_{OCSET}	OCSET Current Source		9	10	11	μA
V_{OCP}	OCP Threshold		-	190	-	mV
	OCB Output Low Voltage	Sink Current=5mA	-	0.5	0.7	V
	OCB Leakage Current	$V_{OCB} = 5V$	-	-	1	μA
$t_{D(OCB)}$	OCB Deglitch Time	OCB go low	-	0.6	-	ms
Over-Temperature Protection (OTP)						
T_{OTR}	OTP Rising Threshold		-	145	-	$^\circ C$
	OTP Hysteresis		-	45	-	$^\circ C$
PWM INPUT PIN						
V_{PWM}	PWM Input Logic Threshold	V_{PWM} Rising	3.6	3.9	4.1	V
		V_{PWM} Falling	1	1.2	1.4	V
V_{TRI}	Tri-state Input Rising Logic Threshold	V_{PWM} Rising	1.0	1.3	1.6	V
		hysteresis	140	280	420	mV
V_{TRI}	Tri-state Input Falling Logic Threshold	V_{PWM} Falling	3.4	3.7	4.0	V
		hysteresis	85	170	255	mV
I_{PWM}	PWM Pin input current	Source/ Sink , $V_{PWM} = 0V$ to $5V$	-1	-	1	μA

Electrical Characteristics

Unless otherwise specified, these specifications apply over VDD=5V. Typical values are at T_A=25°C.

	Parameter	Test Conditions	APW8703/6/7			Unit
			Min	Typ	Max	
EN INPUT AND SMOD Input						
	EN/SMOD Input Logic High		2.0	-	-	V
	EN/SMOD Input Logic Low		-	-	0.8	V
	EN/SMOD Input Current	V _{EN} = 5V or V _{SMOD} =5V	-1	-	1	uA
GATE DRIVER TIMINGS(refer to Figure 1 and Table 1)						
t _{PDLU}	PWM to High side Gate	PWM H to L to GH H to L (Note4)	-	18	-	ns
t _{PDLL}	PWM to Low side Gate	PWM L to H to GL H to L (Note4)	-	25	-	ns
t _{PDHU}	LS to HS Gate Deadtime	GL H to L to GH L to H (Note 4)	-	20	-	ns
t _{PDHL}	HS to LS Gate Deadtime	GH H to L to GL L to H (Note 4)	-	20	-	ns

Note4: Not tested in production.

PWM Operation Characteristics

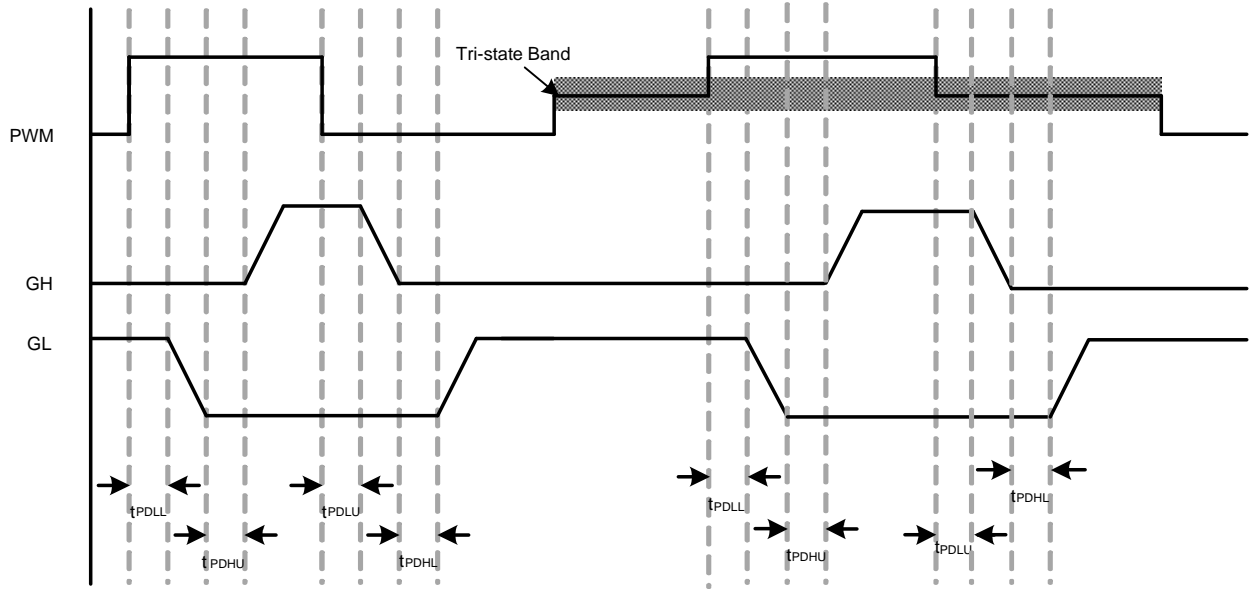

Figure 1 : Timing chart

Table 1 : Truth table

EN	SMOD	PWM	GH	GL
L	X	X	L	L
H	L	H	H	L
H	L	L	L	Skip mode
H	X	Tri-state	L	H
H	H	H	H	L
H	H	L	L	H

Pin Descriptions

PIN		NAME	FUNCTION
NUMBER			
APW8703/6	APW8707		
1	1	OCSET	Over-Current Setting Input. Connect a resistor to GND to set the OCP trip level.
2	2	OCB	Fault Indication Pin. This pin goes low when a OCP condition is detected after a 1ms deglitch time.
3	3	EN	Enable Pin. Logic high enables the device. Logic low disables the device. The pin is not floating.
4	5	SMOD	Skip Mode Input. Pull SMOD high to enter diode emulation or skip mode.
5	4,29,31	AGND	Signal Ground for The IC. All voltage levels are measured with respect to this pin. Tie this pin to the ground island/plane through the lowest impedance connection available.
6	6	PWM	PWM Drive Logic Input.
7	7,28	NC	No Connection.
8,9,22,24	8,9,10,11,32	VIN	Supply Voltage Input Pin for Power Stage.
10,11,16,17,18,25	20,21,22,23,24,25,33	LX	Junction Point of The High-side and Low-side MOSFET. Connect the output LC filter for PWM output voltage.
12,13,14,15,19	12,13,14,15,16,17,18,19,26	PGND	Power ground.
20	27	BST	High-Side Gate Driver Power Input Pin. Connect a 0.1uF capacitor from BST to LX.
21	-	PVCC	Supply Voltage Input Pin for Low Side Gate Driver.
23	30	VCC	Supply voltage Input Pin for Control Circuitry. Decoupling at least 1uF of a MLCC capacitor from the VCC pin to the AGND pin.

Block Diagram

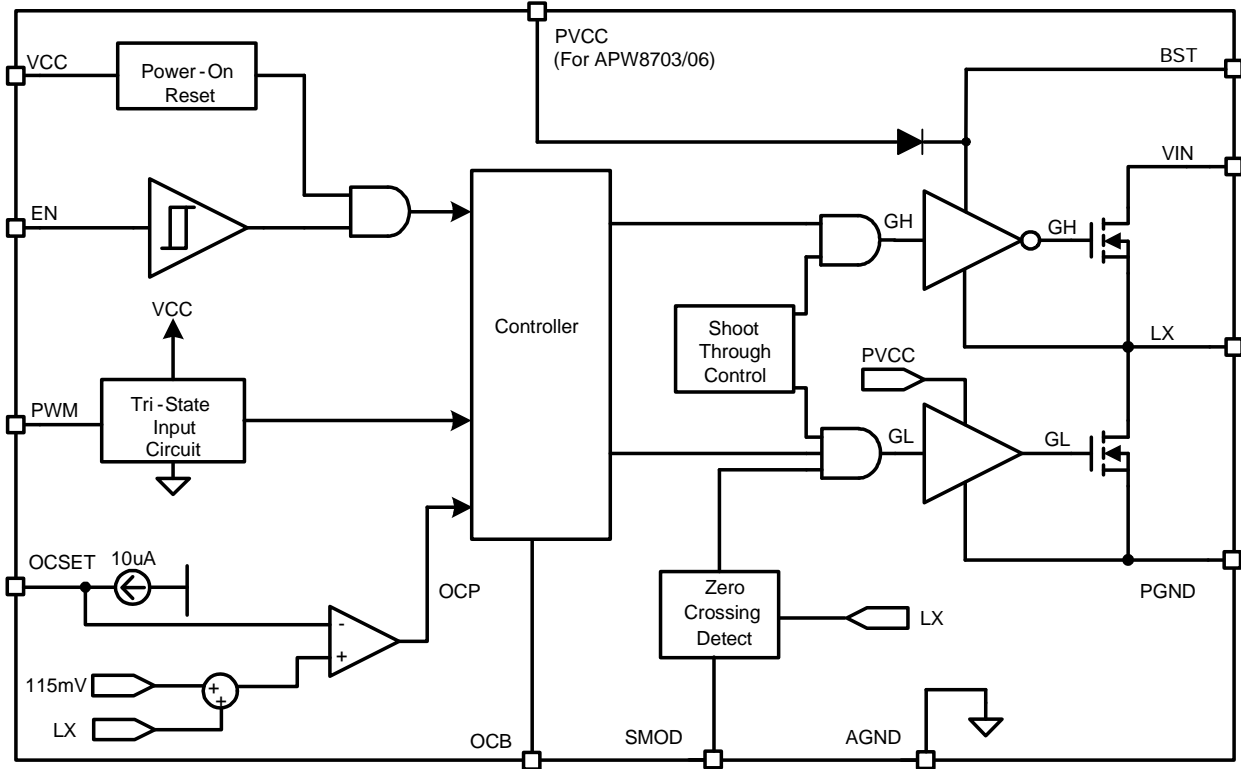

Typical Application Circuit

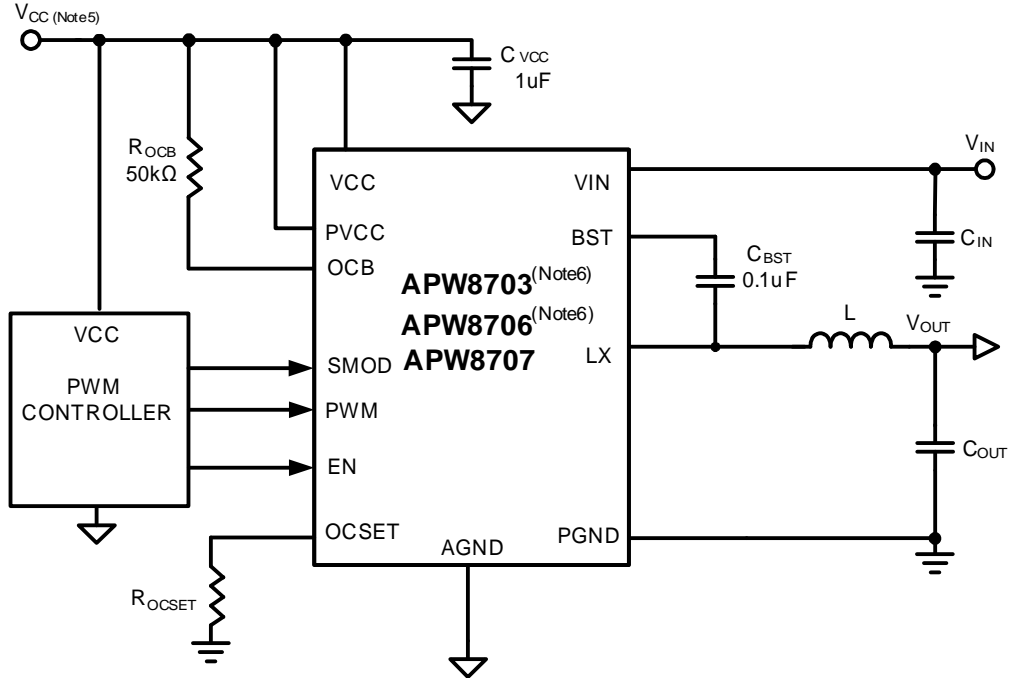

Note 5: VCC voltage rail must be SYNC with PWM controller VCC voltage level.

Note 6: PVCC pin is only for APW8703/06

Function Description

VCC Power-On-Reset (POR)

A Power-On-Reset (POR) function is designed to prevent wrong logic controls when the VCC voltage is low. The POR function continually monitors the bias supply voltage on the VCC pin if at least one of the enable pins is set high. When the VCC supply voltage exceeds the rising POR threshold, the POR enables the device. The POR circuit has a hysteresis and a deglitch feature so that it will typically ignore undershoot transients on the VCC pin.

Enable Control

Pulling the VEN above 2V will enable the driver output, and pulling VEN below 0.8V will disable the driver output. If enable function is not used, connect EN to VCC for normal operation.

PWM Control

The PWM pin has three states. If the pin is gave high level state, the internal pre-driver output of high-side (GH) goes high and internal pre-driver output of low-side (GL) goes low. If the pin is gave low level state, the GH goes low and GL goes high. If the pin is gave tri-state level, the GH goes low and GL goes High. Please refer to Table 1.

SMOD

APW8703/6/7 can be operated in the skip mode using SMOD pin. When SMOD is low, the IC will enter the skip mode. In Skip mode if the PWM is low and the ZC is detected, the GL will be pulled low, and low-side MOSFET will be off. It is useful if the converter has to operation in skip mode to improve efficiency at light load. When SMOD is high, the converter will operate in force PWM mode.

Over-current Protection (OCP)

The over-current protection function protects the switching converter to against over-current or short-circuit conditions. The IC senses the inductor current by detecting the drain to source voltage of low-side MOSFET during it's on-state. When the inductor current is over the internal OCP trip point, the both of gate drivers will be latched off.

The current limit circuit employs a "valley" current-sensing algorithm (See Figure 2). The APW8703/6/7 use the low-side MOSFET's $R_{DS(ON)}$ of the synchronous rectifier as a current-sensing element. If the magnitude of the current-sense signal at LX pin is above the current-limit threshold, the PWM is not allowed to initiate a new cycle. The current-limit threshold is given by:

$$I_{LIMIT} = (190\text{mV} - R_{OCSET} * 10\mu\text{A}) / R_{ON_L}$$

The actual peak current is greater than the current-limit threshold by an amount equal to the inductor ripple current. Therefore, the exact current-limit characteristic and maximum load capability are a function of the sense resistance, inductor value, and input voltage.

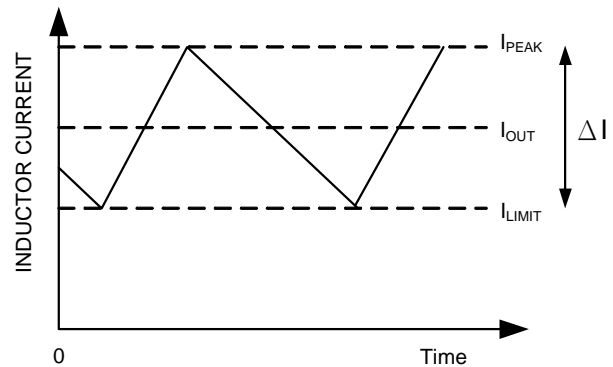

Figure 2. Current Limit algorithm

Over-Temperature Protection (OTP)

When the junction temperature increases above the rising threshold temperature T_{OTR} , the IC will enter the over temperature protection state that suspends the PWM, which forces the UG and LG gate drivers output low. The thermal sensor allows the converters to start a start-up process and regulate the output voltage again after the junction temperature cools by 45°C. The OTP designed with a 45°C hysteresis lowers the average T_j during continuous thermal overload conditions, which increases lifetime of the APW8703/6/7.

OCB Output

The APW8703/6/7 provide an open-drain output to indicate that a fault has occurred. When current-limit occurs for a deglitch time of $t_{D(OCB)}$, the OCB goes low. Since the OCB pin is an open-drain output, connecting a resistor to a pull high voltage is necessary.

Layout Consideration

For all switching power supplies, the layout is an important step in the design; especially at high peak currents and switching frequencies. If the layout is not carefully done, the regulator might show noise problems and duty cycle jitter.

1. The input capacitors should be placed close to the VIN pin, and the ground terminals of input capacitors and output capacitors should be close PGND pin.
2. To minimize copper trace connections that can inject noise into the system, the inductor should be placed as close as possible to the LX pin to minimize the noise coupling into other circuits.
3. The traces of PWM signal from the PWM controller to the PWM pin of APW8703/6/7 should be short to eliminate the parasitical capacitance; the parasitical capacitance will cause an invalid PWM signal.

Package Information

TQFN4x4-23

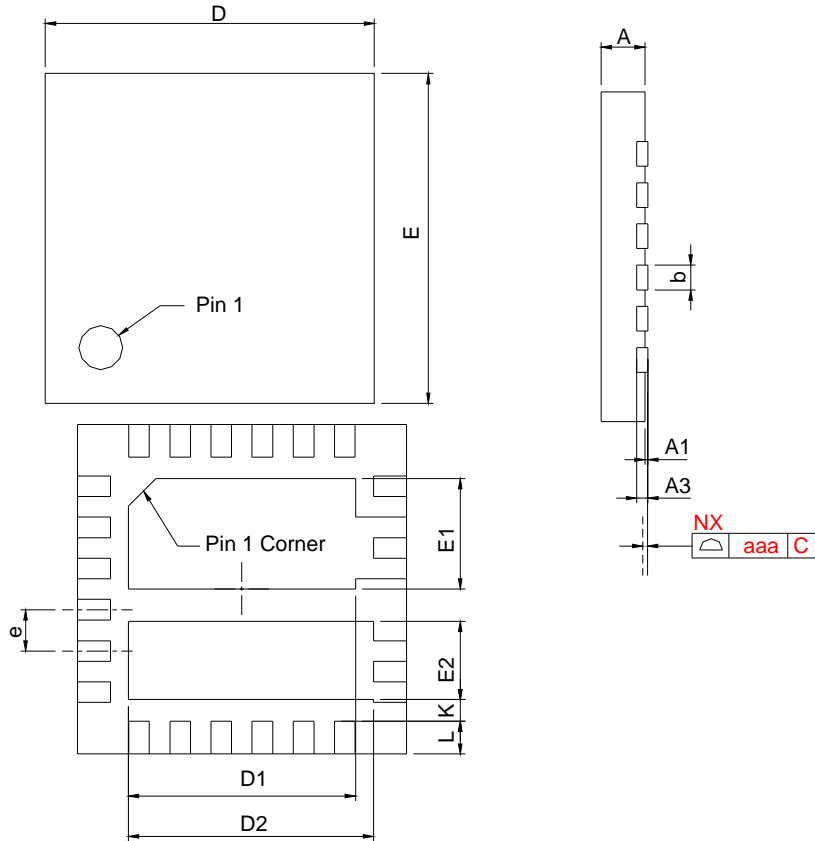

DIMENSIONS	TQFN4x4-23			
	MILLIMETERS		INCHES	
	MIN.	MAX.	MIN.	MAX.
A	0.70	0.80	0.028	0.032
A1	0.00	0.05	0.000	0.002
A3	0.20 REF		0.008 REF	
b	0.20	0.30	0.008	0.012
D	3.90	4.10	0.154	0.161
D1	2.58	2.78	0.102	0.109
D2	2.95	3.15	0.116	0.124
E	3.90	4.10	0.154	0.161
E1	1.24	1.44	0.049	0.057
E2	0.85	1.05	0.033	0.041
e	0.50 BSC		0.020 BSC	
L	0.35	0.45	0.014	0.018
K	0.20		0.008	
aaa	0.08		0.003	

Note : 1. Follow from JEDEC MO-229 WCCD-3.

Package Information

TQFN5x5-30

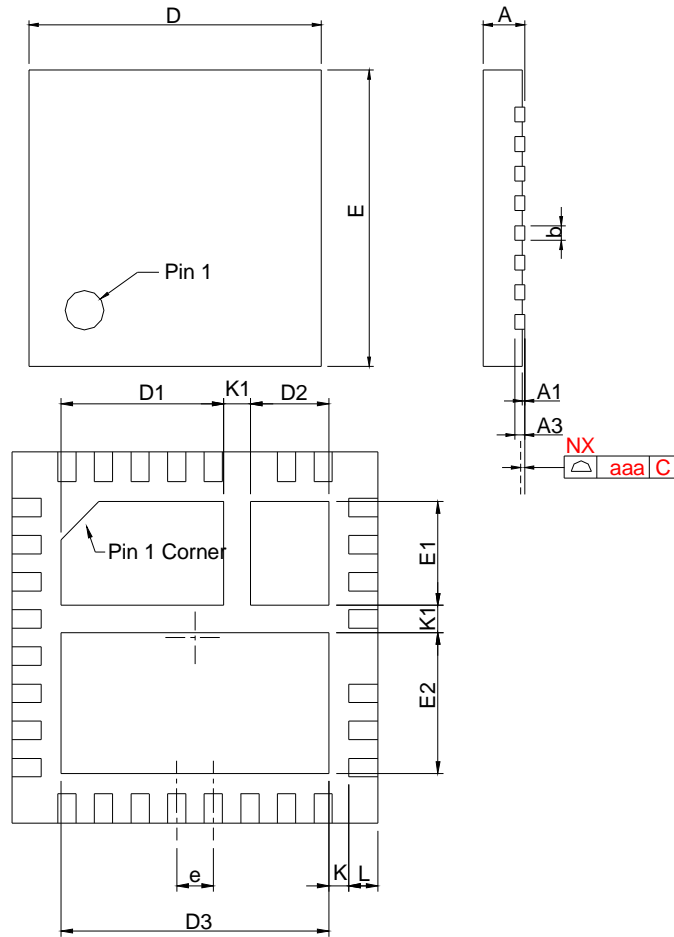

SYMBOL	TQFN5*5-30			
	MILLIMETERS		INCHES	
	MIN.	MAX.	MIN.	MAX.
A	0.70	0.80	0.028	0.031
A1	0.00	0.05	0.000	0.002
A3	0.20 REF		0.008 REF	
b	0.20	0.30	0.008	0.012
D	4.90	5.10	0.193	0.201
D1	2.12	2.32	0.083	0.091
D2	0.97	1.17	0.038	0.046
D3	3.56	3.76	0.140	0.148
E	4.90	5.10	0.193	0.201
E1	1.29	1.49	0.051	0.059
E2	1.80	2.00	0.071	0.079
e	0.50 BSC		0.020 BSC	
L	0.35	0.45	0.014	0.018
K	0.20		0.008	
K1	0.37 REF		0.015 REF	
aaa	0.08		0.003	

Carrier Tape & Reel Dimensions

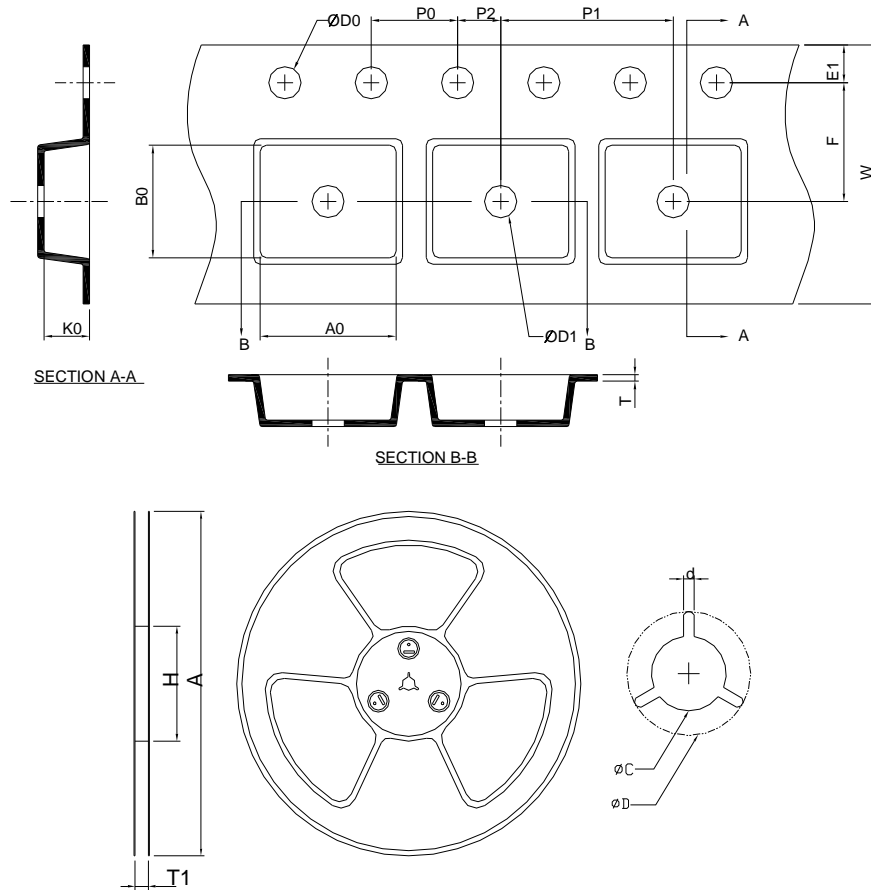

Application	A	H	T1	C	d	D	W	E1	F
TQFN4x4	330.0±2.00	50 MIN.	12.4+2.00 -0.00	13.0+0.50 -0.20	1.5 MIN.	20.2 MIN.	12.0±0.30	1.75±0.10	5.50±0.10
	P0	P1	P2	D0	D1	T	A0	B0	K0
	4.00±0.10	8.00±0.10	2.00±0.05	1.5+0.10 -0.00	1.5 MIN.	0.6+0.00 -0.40	4.30±0.20	4.30±0.20	1.00±0.20
Application	A	H	T1	C	d	D	W	E1	F
TQFN 5x5	330.0±2.00	50 MIN.	12.4+2.00 -0.00	13.0+0.50 -0.20	1.5 MIN.	20.2 MIN.	12.0±0.30	1.75±0.10	5.5±0.10
	P0	P1	P2	D0	D1	T	A0	B0	K0
	4.0±0.10	8.0±0.10	2.0±0.10	1.5+0.10 -0.00	1.5 MIN.	0.6+0.00 -0.40	5.35±0.20	5.35±0.20	1.00±0.20

(mm)

Devices Per Unit

Package Type	Unit	Quantity
TQFN4x4	Tape & Reel	3000
TQFN5x5	Tape & Reel	2500

Taping Direction Information

TQFN4x4-23

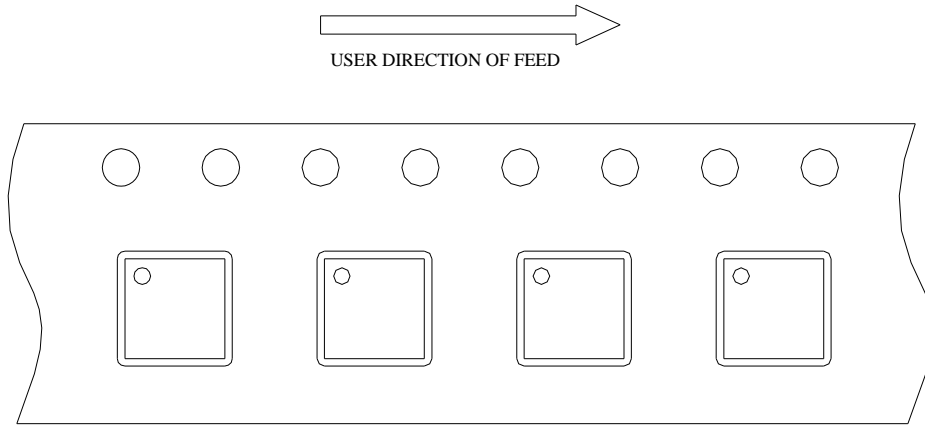

TQFN5x5-30

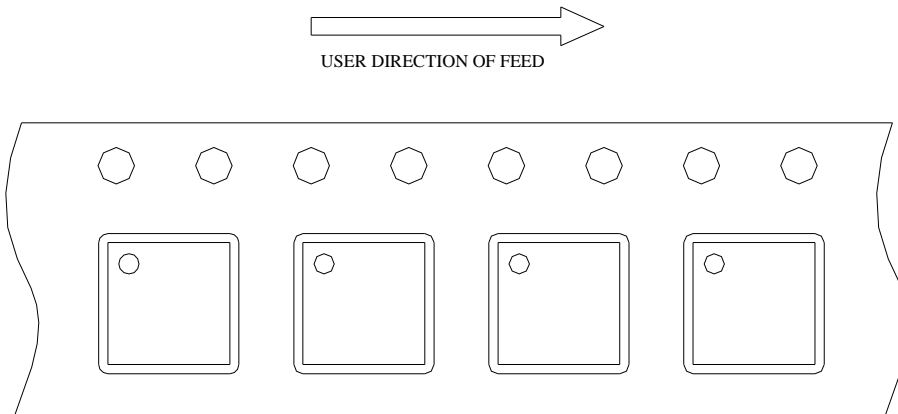

Classification Profile

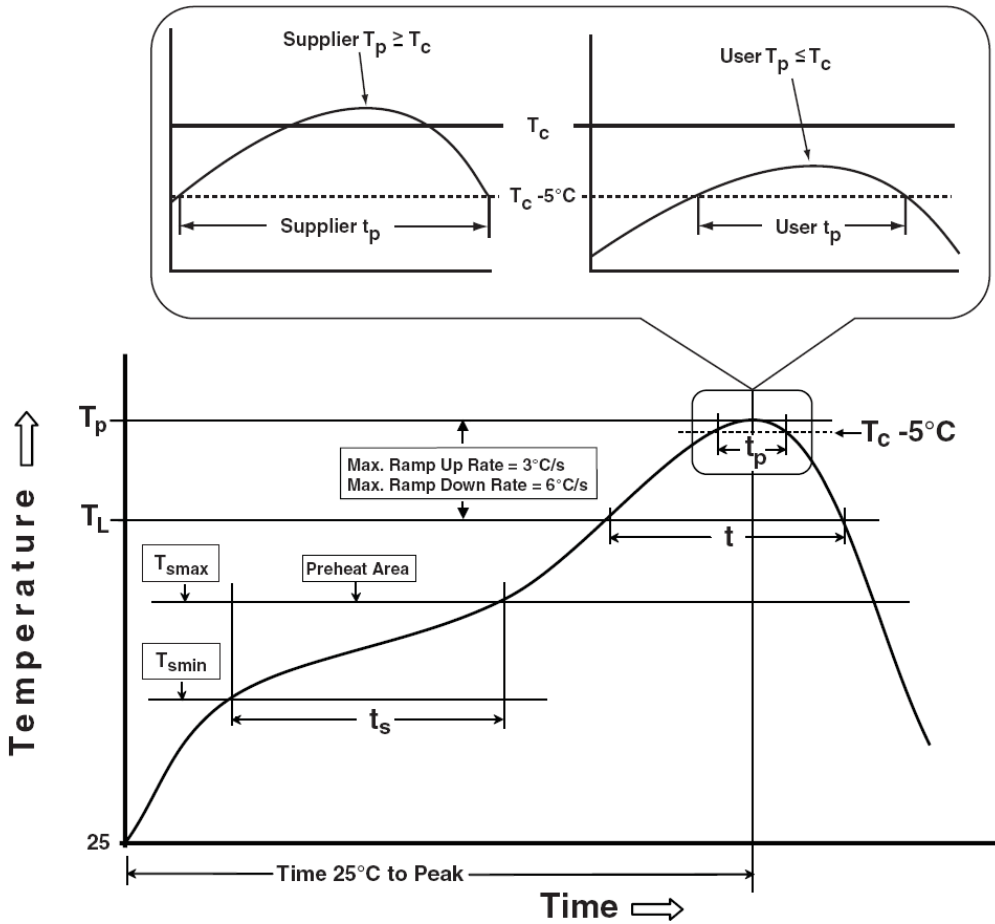

Classification Reflow Profiles

Profile Feature	Sn-Pb Eutectic Assembly	Pb-Free Assembly
Preheat & Soak		
Temperature min (T_{smin})	100 °C	150 °C
Temperature max (T_{smax})	150 °C	200 °C
Time (T_{smin} to T_{smax}) (t_s)	60-120 seconds	60-120 seconds
Average ramp-up rate (T_{smax} to T_p)	3 °C/second max.	3°C/second max.
Liquidous temperature (T_L)	183 °C	217 °C
Time at liquidous (t_L)	60-150 seconds	60-150 seconds
Peak package body Temperature (T_p)*	See Classification Temp in table 1	See Classification Temp in table 2
Time (t_p)** within 5°C of the specified classification temperature (T_c)	20** seconds	30** seconds
Average ramp-down rate (T_p to T_{smax})	6 °C/second max.	6 °C/second max.
Time 25°C to peak temperature	6 minutes max.	8 minutes max.
* Tolerance for peak profile Temperature (T_p) is defined as a supplier minimum and a user maximum.		
** Tolerance for time at peak profile temperature (t_p) is defined as a supplier minimum and a user maximum.		

Table 1. SnPb Eutectic Process – Classification Temperatures (T_c)

Package Thickness	Volume mm ³ <350	Volume mm ³ ≥350
<2.5 mm	235 °C	220 °C
≥2.5 mm	220 °C	220 °C

Table 2. Pb-free Process – Classification Temperatures (T_c)

Package Thickness	Volume mm ³ <350	Volume mm ³ 350-2000	Volume mm ³ >2000
<1.6 mm	260 °C	260 °C	260 °C
1.6 mm – 2.5 mm	260 °C	250 °C	245 °C
≥2.5 mm	250 °C	245 °C	245 °C

Reliability Test Program

Test item	Method	Description
SOLDERABILITY	JESD-22, B102	5 Sec, 245°C
HOLT	JESD-22, A108	1000 Hrs, Bias @ 125°C
PCT	JESD-22, A102	168 Hrs, 100%RH, 2atm, 121°C
TCT	JESD-22, A104	500 Cycles, -65°C~150°C
HBM	MIL-STD-883-3015.7	VHBM ≥ 2KV
MM	JESD-22, A115	VMM ≥ 200V
Latch-Up	JESD 78	10ms, $1_{tr} \geq 100mA$

Customer Service

Anpec Electronics Corp.

Head Office :

No.6, Dusing 1st Road, SBIP,

Hsin-Chu, Taiwan, R.O.C.

Tel : 886-3-5642000

Fax : 886-3-5642050

Taipei Branch :

2F, No. 11, Lane 218, Sec 2 Jhongsing Rd.,

Sindian City, Taipei County 23146, Taiwan

Tel : 886-2-2910-3838

Fax : 886-2-2917-3838