

UNCONTROLLED DOCUMENT

PART NUMBER
SSI-LXH600SIC-150

REV.

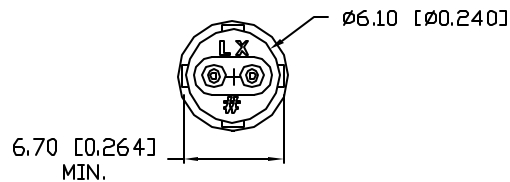
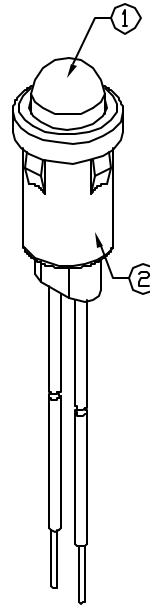
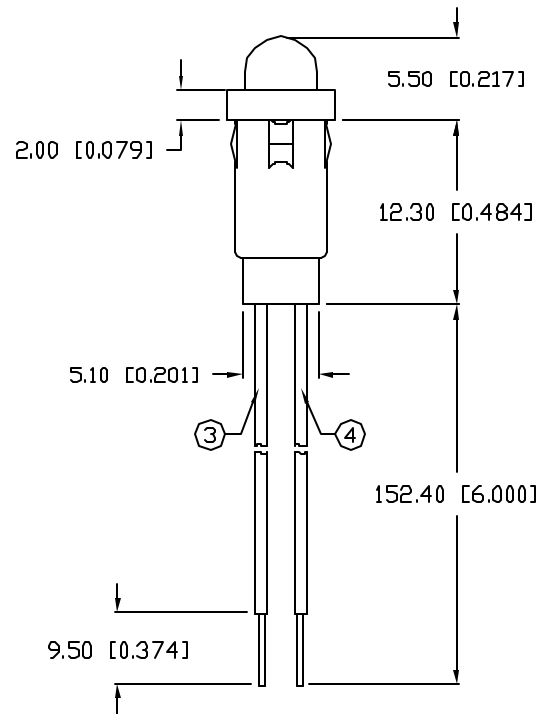
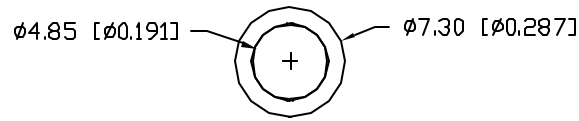

PANEL HOLE: $\varnothing 0.250^*$
PANEL THICKNESS: 0.030" MIN.

ELECTRO-OPTICAL CHARACTERISTICS $T_A=25^\circ\text{C}$ $I_f=20\text{mA}$

PARAMETER	MIN	TYP	MAX	UNITS	TEST COND
PEAK WAVELENGTH		636		nm	
FORWARD VOLTAGE		2.0	2.5	V_f	
REVERSE VOLTAGE	5.0			V_r	$I_f=100\mu\text{A}$
AXIAL INTENSITY		1800		med	$I_f=20\text{mA}$
VIEWING ANGLE		30		2x theta	
EMITTED COLOR:	RED				
EPOXY LENS FINISH:	WATER CLEAR				

LIMITS OF SAFE OPERATION AT 25°C

PARAMETER	MAX	UNITS
PEAK FORWARD CURRENT*	150	mA
STEADY CURRENT	30	mA
POWER DISSIPATION	105	mW
DERATE FROM 25°C	-1.2	mW/°C
OPERATING, STORAGE TEMP.	-40 TO +85	°C
SOLDERING TEMP.	+260	°C
2.0mm FROM BODY		3 SEC. MAX

* $t < 10\mu\text{s}$

NOTES:

1. SSL-LX509F3SK LED.
2. SSH-LXH600 HOLDER, BLACK.
3. ANODE LEAD: LXP-WST24RDT0C, 24 AWG STRANDED, TOP OVERCOAT, RED INSULATION, CUT 160mm LONG, STRIP 4mm & 9.5mm.
4. CATHODE LEAD: LXP-WST24BLT0C, 24 AWG STRANDED, TOP OVERCOAT, BLACK INSULATION, CUT 160mm LONG, STRIP 4mm & 9.5mm.

UNCONTROLLED DOCUMENT

*UNLESS OTHERWISE SPECIFIED TOLERANCES PER DECIMAL PRECISION ARE: X= ± 1 (± 0.039), XX= ± 0.5 (± 0.020), XXX= ± 0.25 (± 0.010), XXXX= ± 0.127 (± 0.005). LEAD SIZE= ± 0.05 (± 0.002), LEAD LENGTH= ± 0.75 (± 0.030), MIN= $\frac{+DECIMAL PRECISION}{-0.00}$, MAX= $\frac{+0.00}{-DECIMAL PRECISION}$

REV.

PART NUMBER

SSI-LXH600SIC-150

T-5mm (T-1 3/4) LED, PANEL MOUNT INDICATOR,
636nm SUPER HIGH INTENSITY RED LED, WATER CLEAR LENS,
WITH 6" WIRE LEADS.

CONFIDENTIAL INFORMATION

THE INFORMATION CONTAINED IN THIS DOCUMENT IS THE PROPERTY OF LUMEX INC. EXCEPT AS SPECIFICALLY AUTHORIZED IN WRITING BY LUMEX INC, THE HOLDER OF THIS DOCUMENT SHALL KEEP ALL INFORMATION CONTAINED HEREIN CONFIDENTIAL AND SHALL PROTECT SAME IN WHOLE OR IN PART FROM DISCLOSURE AND DISSEMINATION TO ALL THIRD PARTIES.

RELIABILITY NOTE

OUR MANY YEARS OF EXPERIENCE DATA ACCUMULATION INDICATE THAT SOLDER HEAT IS A MAJOR CAUSE OF EARLY AND FUTURE FAILURE. PLEASE PAY ATTENTION TO YOUR SOLDERING PROCESS.



290 E. HELEN ROAD
PALATINE, IL 60067-6976
PHONE: +1.847.359.2790
US WEB: www.lumex.com
TW WEB: www.lumex.com.tw

DRAWN BY:

GB

CHECKED BY:

APPROVED BY:

DATE: 4.2.02

PAGE: 1 OF 1

SCALE: N/A