



## POWER DISTRIBUTION SWITCH

### DESCRIPTION

The UTC **US206** is a power distribution switch. It particularly designed for self-powered and bus-powered Universal Serial Bus (USB) applications.

The  $R_{DS(ON)}$  of the MOSFET switch is as low as  $85m\Omega$ .  $\overline{OC}$  is open-drain output report over-current or over-temperature event which has deglitch typical 9ms timeout period typically 9ms.

The UTC **US206** incorporates protection circuits including current limiting circuit with foldback function, thermal shutdown circuit designed to prevent catastrophic switch failure due to increasing power dissipation when continuous heavy loads or short circuit occurs. Besides, a built-in charge pump is used to drive the N-channel MOSFET that is free of parasitic body diode to eliminate any reversed current flow across the switch when it is powered off.

The UTC **US206** is applied in high-side power protection switch, USB power management, USB host and self-powered hubs, USB bus-powered hubs, hot plug-in power supplies, battery-charger circuits.

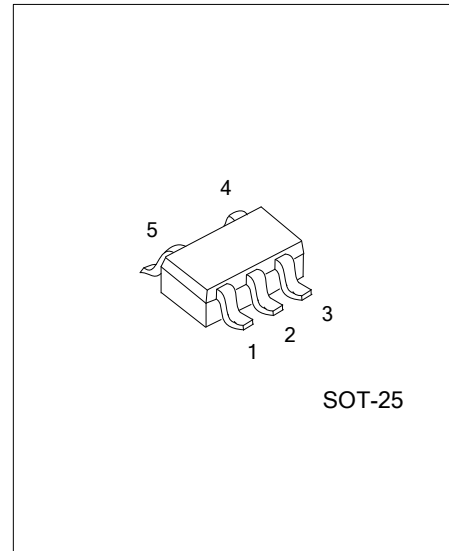

### FEATURES

- \* Operating on The Range of 3.0V to 5.5V
- \* High-Side MOSFET with  $85m\Omega R_{DS(ON)}$
- \* Quiescent Supply Current:  $65\mu A$
- \* Available With 4 Versions of Current Limits with Foldback
- \* Rise Time:  $400\mu S$  (TYP.)
- \* UVLO (Under Voltage Lockout)
- \* Output Shutdown Pull-low Resister
- \* Shutdown Supply Current:  $1\mu A$  (MAX.)
- \* Logic Level Enable Pin, Available with Active-High or Active-Low Version
- \* Reverse Current is Not Generated when in Power Off State
- \* Deglitched Open-Drain Over-Current Flag Output ( $\overline{OC}$ )

### ORDERING INFORMATION

Ordering Number	Package	Packing
US206xG-xx-AF5-R	SOT-25	Tape Reel

<p>US206xG-xx-AF5-R</p> <ul style="list-style-type: none"> <li>(1)Packing Type</li> <li>(2)Package Type</li> <li>(3)Current Limit Threshold</li> <li>(4)Green Package</li> <li>(5)Logic Level Enable Pin</li> </ul>	<ul style="list-style-type: none"> <li>(1) R: Tape Reel</li> <li>(2) AF5: SOT-25</li> <li>(3) 10: 1.4A, 15: 2.1A, 20: 2.8A, 25: 3.5A</li> <li>(4) G: Halogen Free and Lead Free</li> <li>(5) H: Active High, L: Active Low</li> </ul>
---	---

MARKING

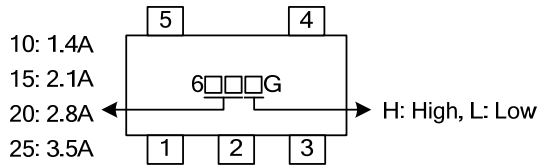

PIN CONFIGURATION

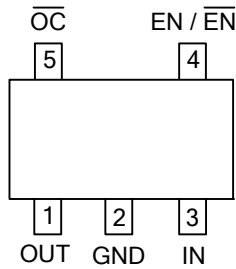

PIN DESCRIPTION

PIN NO.	PIN NAME	DESCRIPTION
1	OUT	Switch Output: Output MOSFET Source. Typically connect to switched side of load.
2	GND	Ground
3	IN	Input Supply: Output MOSFET Drain, which also supplies IC's internal circuitry. Connect to positive supply.
4	EN(EN-bar)	Enable: Logic level enable input. Make sure EN pin never floating.
5	OC-bar	Overcurrent open-drain OC-bar output

BLOCK DIAGRAM

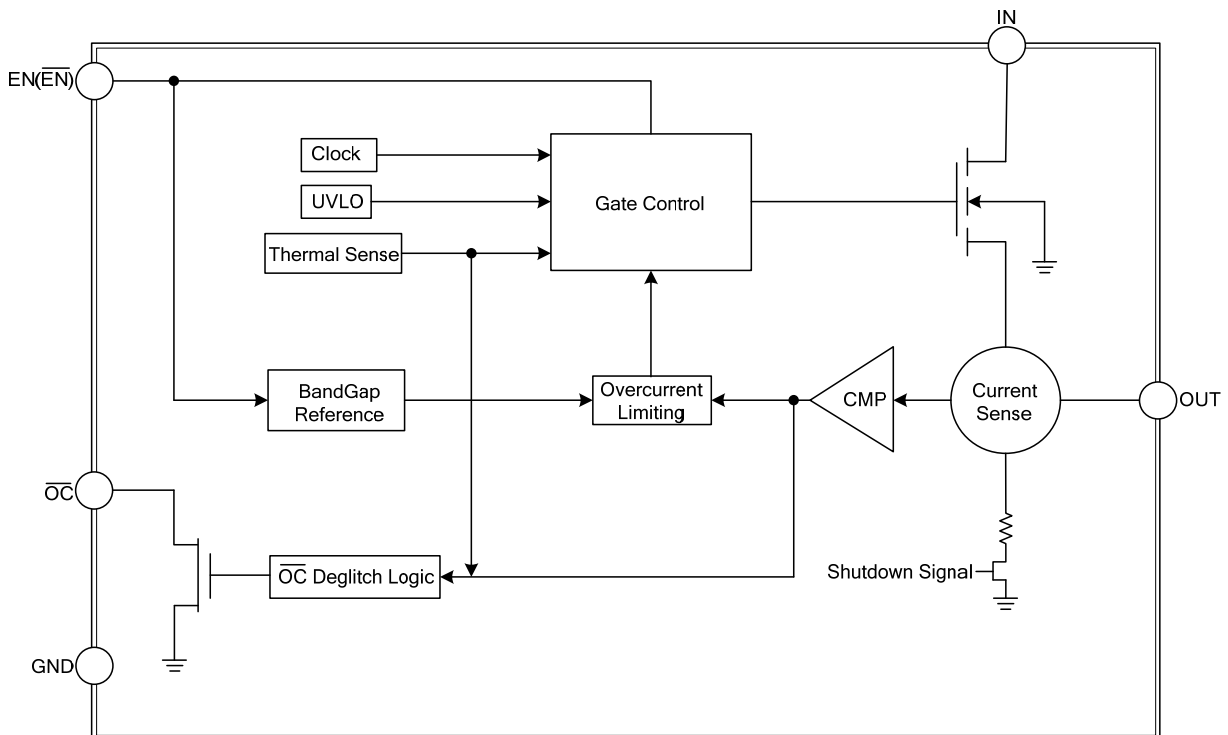

### ■ ABSOLUTE MAXIMUM RATINGS

PARAMETER	SYMBOL	RATINGS	UNIT
Supply Voltage	$V_{IN}$	6	V
Output Voltage	$V_{OUT}$	6	V
Output Current	$I_{OUT}$	Internally Limited	
Power Dissipation ( $T_A = 25^\circ\text{C}$ )	$P_D$	0.4	W
Enable Input	$V_{EN}$	-0.3 ~ 6	V
Storage Temperature	$T_S$	-65 ~ +150	$^\circ\text{C}$
Reflow Temperature (soldering, 10sec)		260	$^\circ\text{C}$

Note: Absolute maximum ratings are those values beyond which the device could be permanently damaged. Absolute maximum ratings are stress ratings only and functional device operation is not implied.

### ■ OPERATING RATINGS

PARAMETER	SYMBOL	RATINGS	UNIT
Supply Voltage	$V_{IN}$	+3 ~ +5.5	V
Operating Temperature	$T_A$	-40 ~ +85	$^\circ\text{C}$

### ■ THERMAL DATA

PARAMETER	SYMBOL	RATINGS	UNIT
Junction to Ambient	$\theta_{JA}$	250	$^\circ\text{C/W}$

### ■ ELECTRICAL CHARACTERISTICS

( $V_{IN}=5\text{V}$ ,  $C_{IN}=1\mu\text{F}$ ,  $C_{OUT}=1\mu\text{F}$ ,  $R_L=10\Omega$ ,  $T_A=25^\circ\text{C}$ , unless otherwise noted.)

PARAMETER	SYMBOL	TEST CONDITIONS	MIN	TYP	MAX	UNIT	
Input Voltage Range	$V_{IN}$				5.5	V	
Output MOS $R_{DS(ON)}$	$R_{DS(ON)}$	$I_{OUT}=2\text{A}$	US206-25	85	95	$\text{m}\Omega$	
		$I_{OUT}=1.5\text{A}$	US206-20				
		$I_{OUT}=1\text{A}$	US206-15				
		$I_{OUT}=0.5\text{A}$	US206-10				
Supply Current	$I_{ON}$			65		$\mu\text{A}$	
Output Turn-on Rising Time	$T_{ON}$	$R_L=10\Omega$ , 90% Settling		400		$\mu\text{s}$	
Current Limit Threshold	$I_{OC}$	$V_{OUT}=4\text{V}$	US206-25	2.0	2.5	3.5	A
			US206-20	1.5	2.0	2.8	
			US206-15	1.1	1.5	2.1	
			US206-10	0.7	1.0	1.4	
Short-circuit Current	$I_{SC}$	$V_{OUT}=0\text{V}$	US206-25	0.2	1.6	2.3	A
			US206-20	0.2	1.3	1.9	
			US206-15	0.2	1.0	1.4	
			US206-10	0.2	0.67	1.0	
EN Input Threshold	$V_{EN}$		1.4	1.6	1.8	V	
Shutdown Supply Current	$I_{OFF}$			0.1	1	$\mu\text{A}$	
Output Leakage Current	$I_{LEAK}$	EN="0", $V_{OUT}=0\text{V}$		0.5	1	$\mu\text{A}$	
$V_{IN}$ Under Voltage Lockout	$V_{UVLO}$		2.0	2.5	3.0	V	
$V_{IN}$ Under Voltage Hysteresis	$\Delta V_{UVLO}$			200		mV	
Thermal Limit	$T_{OT}$			135		$^\circ\text{C}$	
Thermal Limit Hysteresis	$\Delta T_{OT}$			20		$^\circ\text{C}$	
$\overline{\text{OC}}$ Deglitch	$T_{OC}$	UTC US206, $\overline{\text{OC}}$ assertion or deassertion	4	9	15	ms	
$\overline{\text{OC}}$ Output Low Voltage	$V_{OC}$	UTC US206, $I_{\overline{\text{OC}}} = 5\text{mA}$			0.4	V	
$\overline{\text{OC}}$ Off-State Current	$I_{OC-OFF}$	UTC US206, $V_{\overline{\text{OC}}} = 5\text{V}$			1	$\mu\text{A}$	

## ■ TYPICAL APPLICATION CIRCUIT

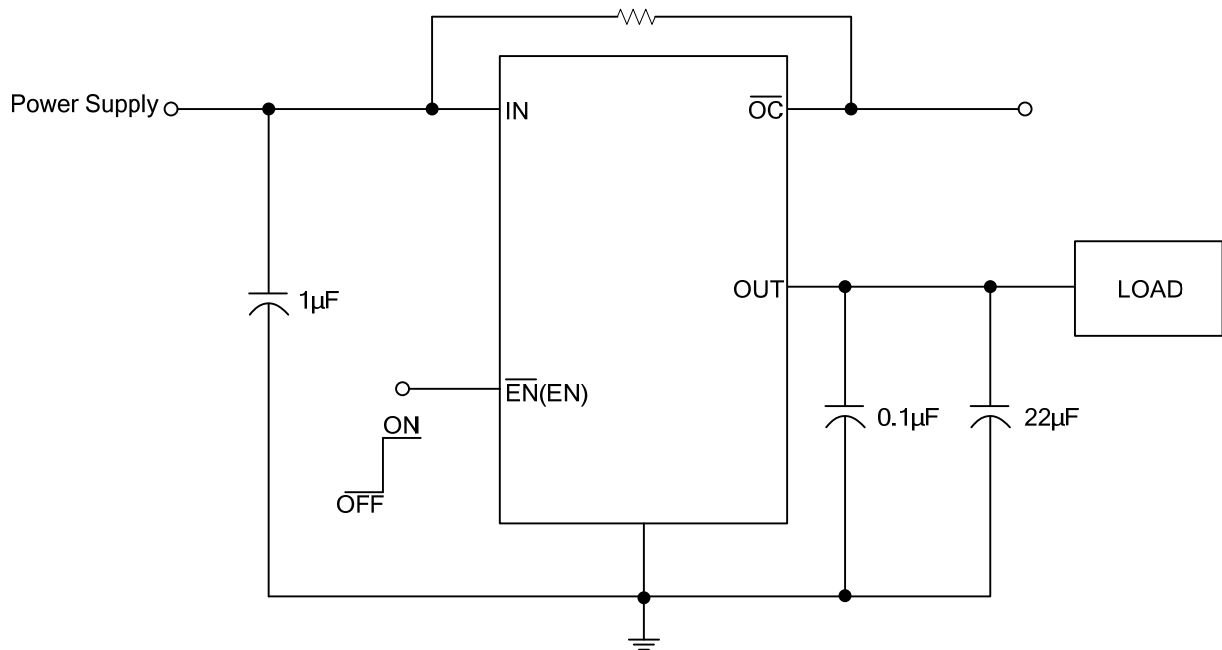

UTC assumes no responsibility for equipment failures that result from using products at values that exceed, even momentarily, rated values (such as maximum ratings, operating condition ranges, or other parameters) listed in products specifications of any and all UTC products described or contained herein. UTC products are not designed for use in life support appliances, devices or systems where malfunction of these products can be reasonably expected to result in personal injury. Reproduction in whole or in part is prohibited without the prior written consent of the copyright owner. The information presented in this document does not form part of any quotation or contract, is believed to be accurate and reliable and may be changed without notice.