



CYPRESS

CY7C1299A

# 32K x 36 Dual I/O Dual Address Synchronous SRAM

## Features

- Fast clock speed: 100 and 83 MHz
- Fast access times: 5.0/6.0 ns max.
- Single clock operation
- Single 3.3V –5% and +5% power supply  $V_{CC}$
- Separate  $V_{CCQ}$  for output buffer
- Two chip enables for simple depth expansion
- Address, data input, CE1, CE2, PTX, PTY, WEX, WEY, and data output registers on-chip
- Concurrent Reads and Writes
- Two bidirectional data buses
- Can be configured as separate I/O
- Pass-through feature
- Asynchronous output enables ( $\overline{OEX}$ ,  $\overline{OEY}$ )
- LVTTTL-compatible I/O
- Self-timed Write
- Automatic power-down
- 176-pin TQFP package

## Functional Description

The CY7C1299A SRAM integrates 32,768 x 36 SRAM cells with advanced synchronous peripheral circuitry. It employs high-speed, low-power CMOS designs using advanced triple-layer polysilicon, double-layer metal technology. Each memory cell consists of four transistors and two high-valued resistors.

The CY7C1299A allows the user to concurrently perform Reads, Writes, or pass-through cycles in combination on the two data ports. The two address ports (AX, AY) determine the read or write locations for their respective data ports (DQX, DQY).

All input pins except output enable pins ( $\overline{OEX}$ ,  $\overline{OEY}$ ) are gated by registers controlled by a positive-edge-triggered clock input (CLK). The synchronous inputs include all addresses, all data inputs, depth-expansion chip enables ( $\overline{CE1}$ ,  $\overline{CE2}$ ), pass-through controls (PTX and PTY), and read-write control (WEX and WEY). The pass-through feature allows data to be passed from one port to the other, in either direction. The PTX input must be asserted to pass data from port X to port Y. The PTY will likewise pass data from port Y to port X. A pass-through operation takes precedence over a read operation.

For the case when AX and AY are the same, certain protocols are followed. If both ports are read, the reads occur normally. If one port is written and the other is read, the read from the array will occur before the data is written. If both ports are written, only the data on DQY will be written to the array.

The CY7C1299A operates from a +3.3V power supply. All inputs and outputs are LVTTTL compatible. These dual I/O, dual address synchronous SRAMs are well suited for ATM, Ethernet switches, routers, cell/frame buffers, SNA switches and shared memory applications.

The CY7C1299A needs one extra cycle after power for proper power-on reset. The extra cycle is needed after  $V_{CC}$  is stable on the device. This device is available in a 176-pin TQFP package.

Logic Block Diagram<sup>[1]</sup>

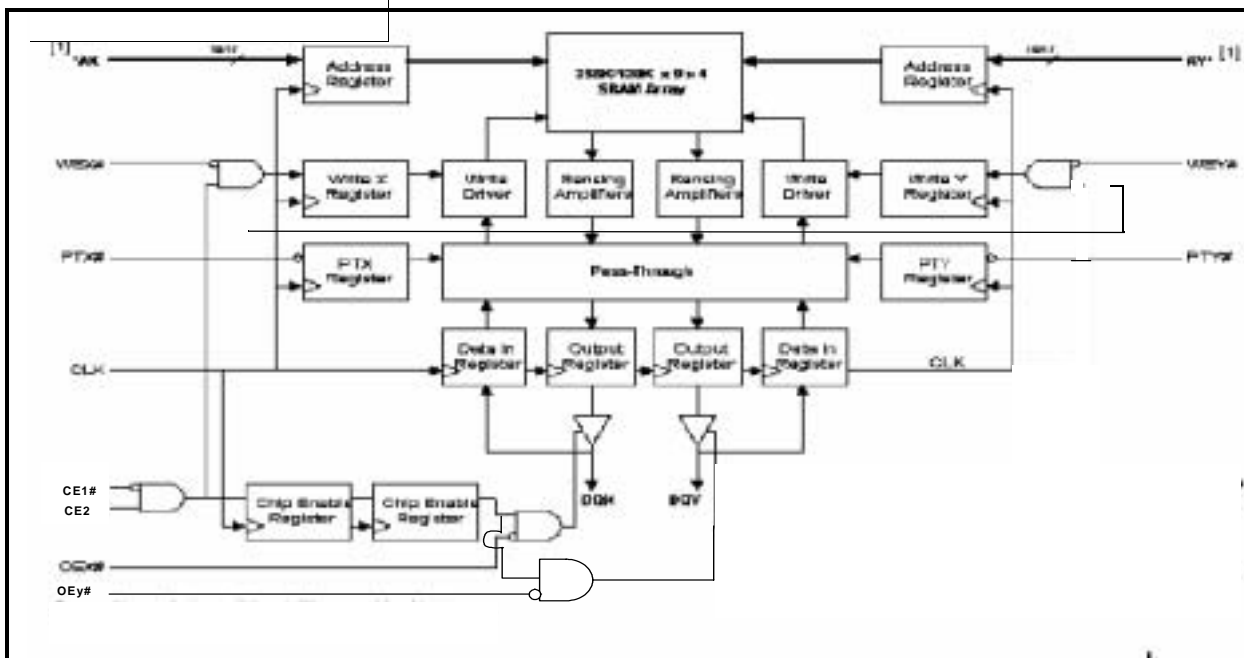

Note:

1. For 32K x 36 devices, AX and AY are 15-bit-wide buses.

Package Description

176-pin TQFP

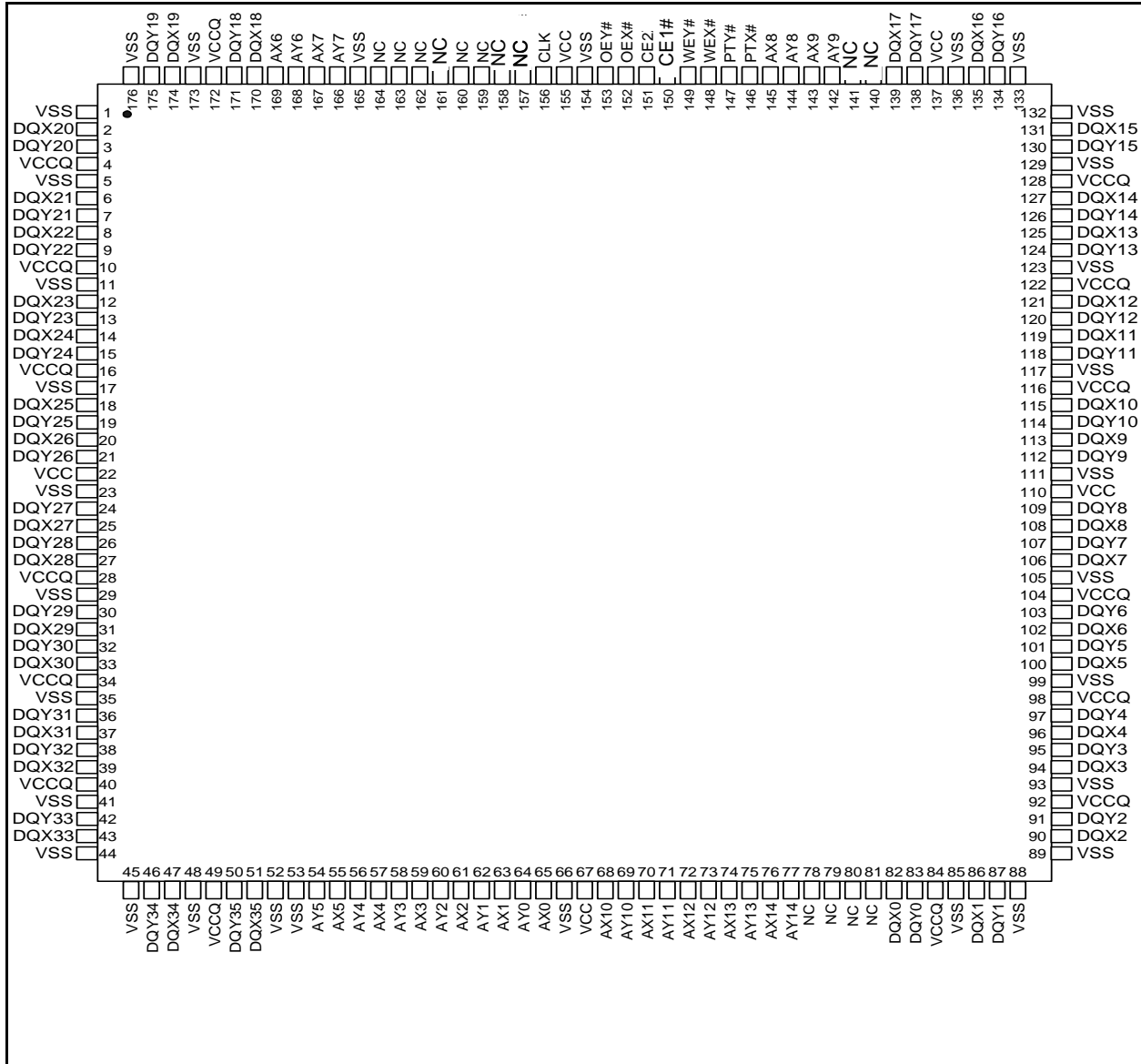

Selection Guide

	-100	-83	Unit
Maximum Access Time	5.0	6.0	ns
Maximum Operating Current	500	430	mA
Maximum CMOS Standby Current	100	100	mA

**Pin Definitions**

Name	I/O	Description
AX0 – AX14	Input-Synchronous	<b>Synchronous Address Inputs of Port X:</b> Do not allow address pins to float.
AY0 – AY14	Input-Synchronous	<b>Synchronous Address Inputs of Port Y:</b> Do not allow address pins to float.
WEX	Input-Synchronous	<b>Read Write of Port X:</b> WEX signal is a synchronous input that identifies whether the current loaded cycle is a Read or Write operation.
WEY	Input-Synchronous	<b>Read Write of Port Y:</b> WEY signal is a synchronous input that identifies whether the current loaded cycle is a Read or Write operation.
PTX	Input-Synchronous	<b>Pass-through of Port X:</b> PTX signal is synchronous input that enables passing Port X input to Port Y output.
PTY	Input-Synchronous	<b>Pass-through of Port Y:</b> PTY signal is synchronous input that enables passing Port Y input to Port X output.
OEX	Input	<b>Asynchronous Output Enable of Port X:</b> OEX must be LOW to read data. When OEX is HIGH, the DQXx pins are in high-impedance state.
OEY	Input	<b>Asynchronous Output Enable of Port Y:</b> OEY must be LOW to read data. When OEY is HIGH, the DQYx pins are in high impedance state.
DQX0–DQX35	Input/Output	<b>Data Inputs/Outputs of Port X:</b> Both the data input path and data output path are registered and triggered by the rising edge of CLK.
DQY0–DQY35	Input/Output	<b>Data Inputs/Outputs of Port Y:</b> Both the data input path and data output path are registered and triggered by the rising edge of CLK.
CLK	Input-Synchronous	<b>Clock:</b> This is the clock input to this device. Except for OEX and OEY, timing references of the address, data in, and all control signals for the device are made with respect to the rising edge of CLK.
CE1	Input-Synchronous	<b>Synchronous Active Low Chip Enable:</b> CE1 sampled HIGH at the rising edge of clock initiates a deselect cycle.
CE2	Input-Synchronous	<b>Synchronous Active High Chip Enable:</b> CE2 sampled LOW at the rising edge of clock initiates a deselect cycle.
VCC	Supply	<b>Power Supply:</b> +3.3V –5% and +5%.
VSS	Ground	<b>Ground:</b> GND.
VSS	Ground	<b>Ground:</b> GND. No chip current flows through these pins. However, user needs to connect GND to these pins.
VCCQ	I/O Supply	<b>Output Buffer Supply:</b> +3.3V –5% and +5%.
NC	–	<b>No Connect:</b> These signals are not internally connected. User can connect them to V <sub>CC</sub> , V <sub>SS</sub> , or any signal lines or simply leave them floating.

**Cycle Description Truth Table** [2, 3, 4, 5, 6, 7, 8, 9]

Operation	CE1	CE2	WEX	WEY	PTX	PTY
Deselect Cycle	H	X	X	X	X	X
Deselect Cycle	X	L	X	X	X	X
Write PORT X	L	H	0	X	X	X
Write PORT Y	L	H	X	0	X	X
Pass-Through from X to Y	L	H	X	X	0	X
Pass-Through from Y to X	L	H	X	X	X	0
read PORT X	L	H	1	X	1	1
read PORT Y	L	H	X	1	1	1

**Notes:**

- X means "don't care." H means logic HIGH. L means logic LOW.
- All inputs except OEX and OEY must meet set-up and hold times around the rising edge (LOW to HIGH) of CLK.
- OEX and OEY must be asserted to avoid bus contention during Write and Pass-Through cycles. For a Write and Pass-Through operation following a Read operation, OEX/OEY must be HIGH before the input data required set-up time plus High-Z time for OEX/OEY and staying HIGH throughout the input data hold time.
- Operation number 3–6 can be used in any combination.
- Operation number 4 and 7, 3 and 8, 7 and 8 can be combined.
- Operation number 5 can not be combined with operation number 7 or 8 because Pass-Through operation has higher priority over a Read operation.
- Operation number 6 can not be combined with operation number 7 or 8 because Pass-Through operation has higher priority over a Read operation.
- This device contains circuitry that will ensure the outputs will be in High-Z during power-up.

**Maximum Ratings**

(Above which the useful life may be impaired. For user guidelines, not tested.)

Storage Temperature ..... -55°C to +125°C

Ambient Temperature with Power Applied..... -10°C to +85°C

Supply Voltage on V<sub>CC</sub> Relative to GND..... -0.5V to +4.6V

DC Voltage Applied to Outputs in High-Z State<sup>[10]</sup>..... -0.5V to V<sub>CCQ</sub> + 0.5V

DC Input Voltage<sup>[10]</sup>..... -0.5V to V<sub>CCQ</sub> + 0.5V

Current into Outputs (LOW)..... 20 mA

Static Discharge Voltage..... > 1601V (per MIL-STD-883, Method 3015)

Latch-up Current..... > 200 mA

**Operating Range**

Range	Ambient Temperature <sup>[11]</sup>	V <sub>CC</sub> /V <sub>CCQ</sub> <sup>[12,21,22]</sup>
Com'l	0°C to +70°C	3.3V ± 5%

**Electrical Characteristics Over the Operating Range**

Parameter	Description	Test Conditions	Min.	Max.	Unit
V <sub>CC</sub>	Power Supply Voltage		3.135	3.465	V
V <sub>CCQ</sub>	I/O Supply Voltage		3.135	3.465	V
V <sub>OH</sub>	Output HIGH Voltage	V <sub>CC</sub> = Min., I <sub>OH</sub> = -4.0 mA	2.4		V
V <sub>OL</sub>	Output LOW Voltage	V <sub>CC</sub> = Min., I <sub>OL</sub> = 8.0 mA		0.4	V
V <sub>IH</sub>	Input HIGH Voltage <sup>[13]</sup>		2.0	V <sub>CC</sub> + 0.5V	V
V <sub>IL</sub>	Input LOW Voltage <sup>[14]</sup>		-0.5	0.8	V
I <sub>X</sub>	Input Load Current	GND ≤ V <sub>IN</sub> ≤ V <sub>CCQ</sub>	-5	5	μA
I <sub>OZ</sub>	Output Leakage Current	GND ≤ V <sub>IN</sub> ≤ V <sub>CCQ</sub> , Output Disabled	-5	5	μA
I <sub>CC</sub>	V <sub>CC</sub> Operating Supply	V <sub>CC</sub> = Max., I <sub>OUT</sub> = 0 mA, f = f <sub>MAX</sub> = 1/t <sub>CYC</sub>			
		10-ns cycle, 100 MHz		500	mA
		12-ns cycle, 83MHz		430	mA
I <sub>SB</sub>	Automatic CE Power-down Current—CMOS Inputs	Max. V <sub>CC</sub> , Device Deselected <sup>[15]</sup> , V <sub>IN</sub> ≤ 0.3V or V <sub>IN</sub> ≥ V <sub>CCQ</sub> - 0.3V, f = f <sub>MAX</sub> = 1/t <sub>CYC</sub>			
		10-ns cycle, 100 MHz		140	mA
		12-ns cycle, 83MHz		120	mA

**Capacitance<sup>[16]</sup>**

Parameter	Description	Test Conditions	Max.	Unit
C <sub>IN</sub>	Input Capacitance	T <sub>A</sub> = 25°C, f = 1 MHz, V <sub>CC</sub> = 3.3V, V <sub>CCQ</sub> = 3.3V	8	pF
C <sub>CLK</sub>	Clock Input Capacitance		9	pF
C <sub>I/O</sub>	Input/Output Capacitance		8	pF

**Notes:**

10. Minimum voltage equals -2.0V for pulse duration less than 20 ns.
11. T<sub>A</sub> is the case temperature.
12. Power supply ramp up should be monotonic.
13. Overshoot: V<sub>IH</sub> ≤ +6.0V for t ≤ t<sub>KC</sub>/2.
14. Undershoot: V<sub>IL</sub> ≤ -2.0V for t ≤ t<sub>KC</sub>/2.
15. "Device Deselected" means the device is in power-down mode as defined in the truth table.
16. Tested initially and after any design or process change that may affect these parameters.

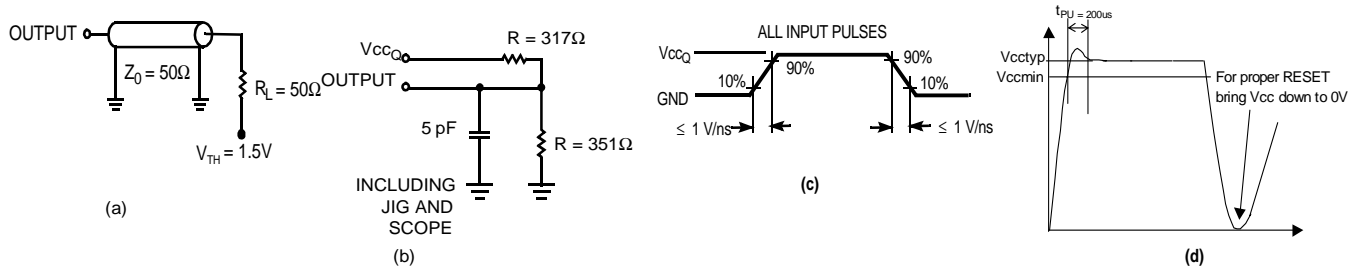
**AC Test Loads and Waveforms<sup>[17]</sup>**

**Thermal Resistance<sup>[16]</sup>**

Parameter	Description	Test Conditions	TQFP Typ.	Unit
$\Theta_{JA}$	Thermal Resistance (Junction to Ambient)	(@200 lfm) Single-layer printed circuit board	40	°C/W
$\Theta_{JC}$	Thermal Resistance (Junction to Ambient)	(@200 lfm) Four-layer printed circuit board	35	°C/W
$\Theta_{JA}$	Thermal Resistance (Junction to Board)	Bottom	23	°C/W
$\Theta_{JC}$	Thermal Resistance (Junction to Case)	Top	9	°C/W

**Switching Characteristics Over the Operating Range<sup>[17, 18, 19]</sup>**

Parameter	Description	-100		-83		Unit
		Min.	Max.	Min.	Max.	
<b>Clock</b>						
$t_{KC}$	Clock cycle time	10		12		ns
$t_{KH}$	Clock HIGH time	3.5		4.0		ns
$t_{KL}$	Clock LOW time	3.5		4.0		ns
<b>Output times</b>						
$t_{KQ}$	Clock to output valid		5.0		6.0	ns
$t_{KQX}$	Clock to output invalid	1.5		1.5		ns
$t_{KQLZ}$	Clock to output in Low-Z <sup>[20]</sup>	0		0		ns
$t_{KQHZ}$	Clock to output in High-Z <sup>[20]</sup>		3.0		3.0	ns
$t_{OEQ}$	OEX/OEY to output valid		5.0		6.0	ns
$t_{OELZ}$	OEX/OEY to output in Low-Z <sup>[20]</sup>	0		0		ns
$t_{OEHZ}$	OEX/OEY to output in High-Z <sup>[20]</sup>		3.0		3.0	ns
<b>Set-up times</b>						
tS	Addresses, Controls and Data In	1.8		2.0		ns
<b>Hold times</b>						
tH	Addresses, Controls and Data In	0.5		0.5		ns

**Notes:**

17. Overshoot:  $V_{IH}(AC) < V_{cc} + 1.5V$  for  $t < t_{TCYC}/2$ ; undershoot:  $V_{IL}(AC) < 0.5V$  for  $t < t_{TCYC}/2$ ; power-up:  $V_{IH} < 2.6V$  and  $V_{cc} < 2.4V$  and  $V_{ccQ} < 1.4V$  for  $t < 200$  ms.
18.  $t_{CHZ}$ ,  $t_{CLZ}$ ,  $t_{OEV}$ ,  $t_{EOLZ}$ , and  $t_{EOHZ}$  are specified with AC test conditions shown in part (a) of AC Test Loads. Transition is measured  $\pm 200$  mV from steady-state voltage.
19. At any given voltage and temperature,  $t_{EOHZ}$  is less than  $t_{EOLZ}$  and  $t_{CHZ}$  is less than  $t_{CLZ}$  to eliminate bus contention between SRAMs when sharing the same data bus. These specifications do not imply a bus contention condition, but reflect parameters guaranteed over worst case user conditions. Device is designed to achieve High-Z prior to Low-Z under the same system conditions.
20. This parameter is sampled and not 100% tested.
21. Please refer to waveform (d).
22. The ground level at the start of "power on" on the Vcc pins should be no greater than 200 mV.

Switching Waveforms [23]

Read Cycle Timing from Both Ports ( $\overline{WEX}$ ,  $\overline{WEY}$ ,  $\overline{PTX}$ ,  $\overline{PTY}$  HIGH)

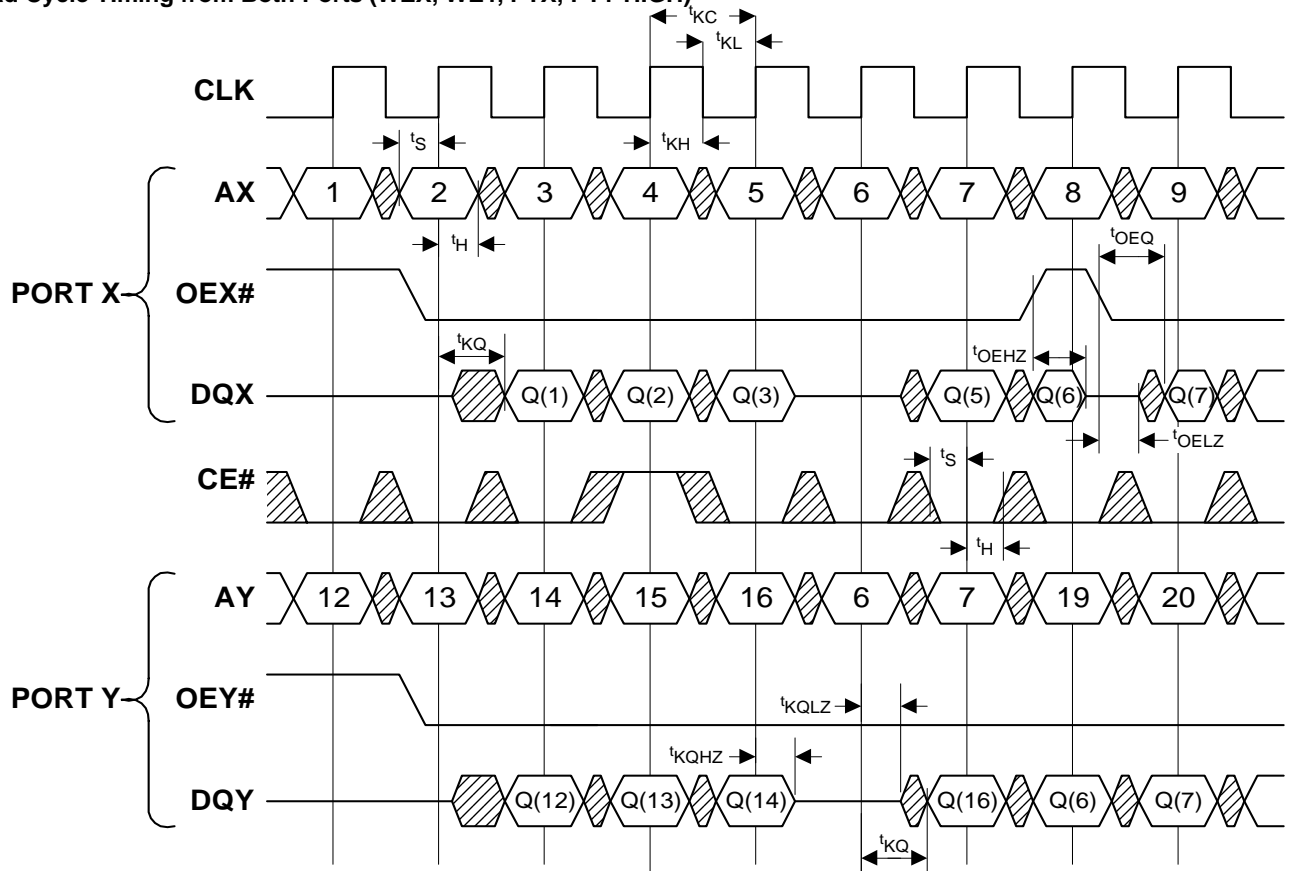

Note:

23.  $\overline{CE}$  LOW means  $\overline{CE1}$  equals LOW and CE2 equals HIGH.  $\overline{CE}$  HIGH means  $\overline{CE1}$  equals HIGH or CE2 equals LOW.

Switching Waveforms (continued)<sup>[23]</sup>

Write Cycle Timing to Both Ports ( $\overline{PTX}$ ,  $\overline{PTY}$  HIGH)

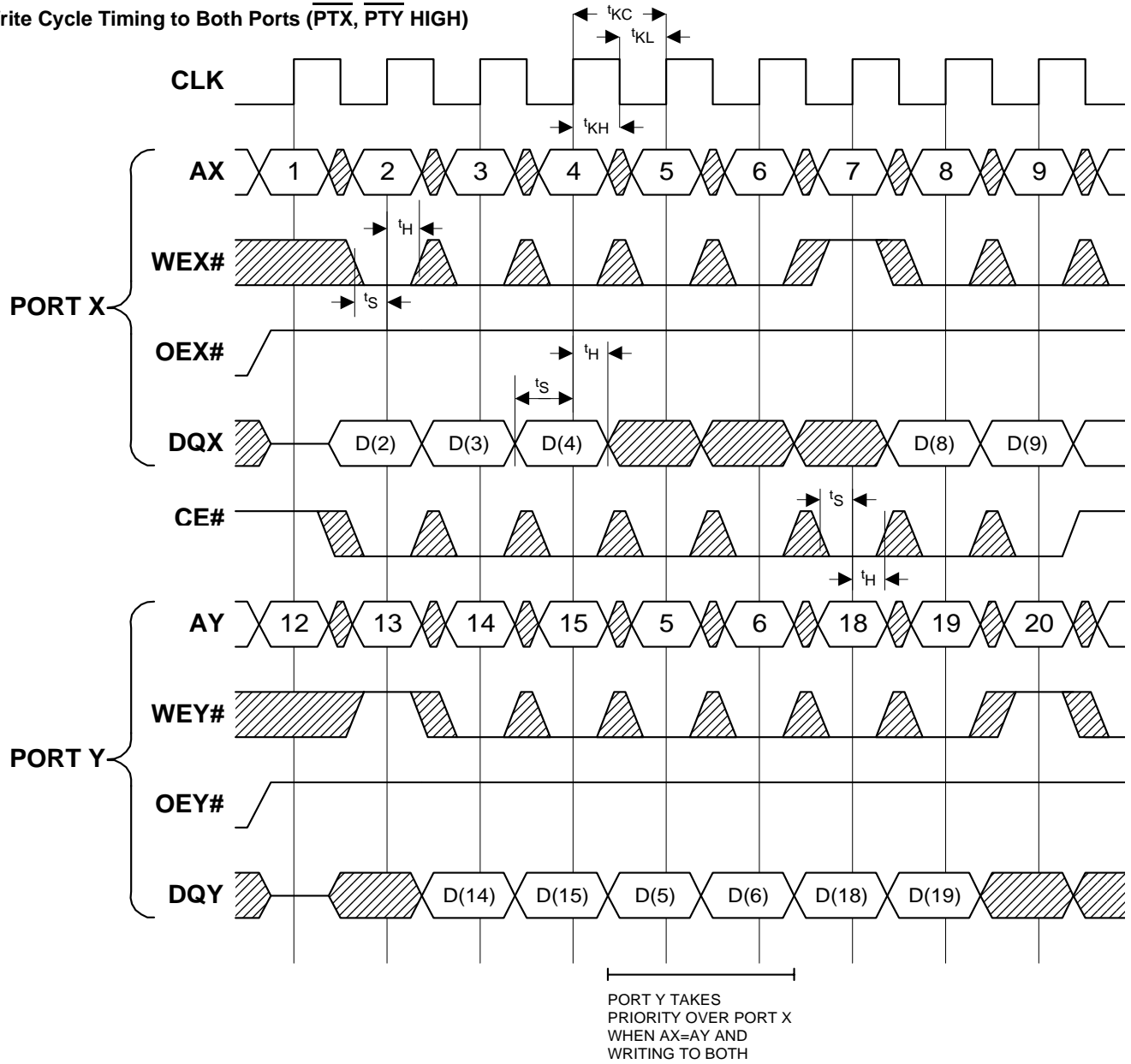

Switching Waveforms (continued)<sup>[23]</sup>

Write to Port X and Pass-Through to Port Y

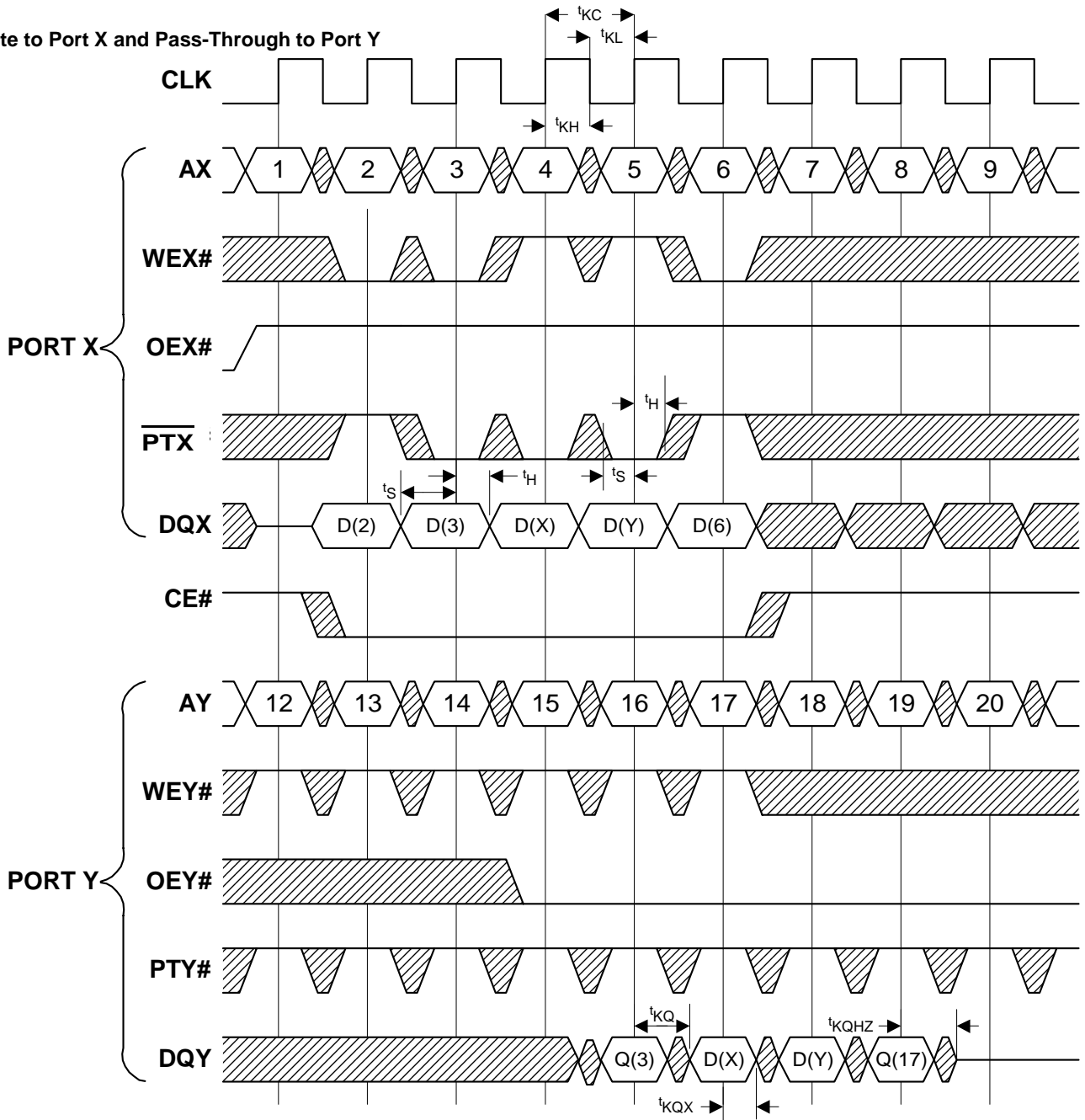

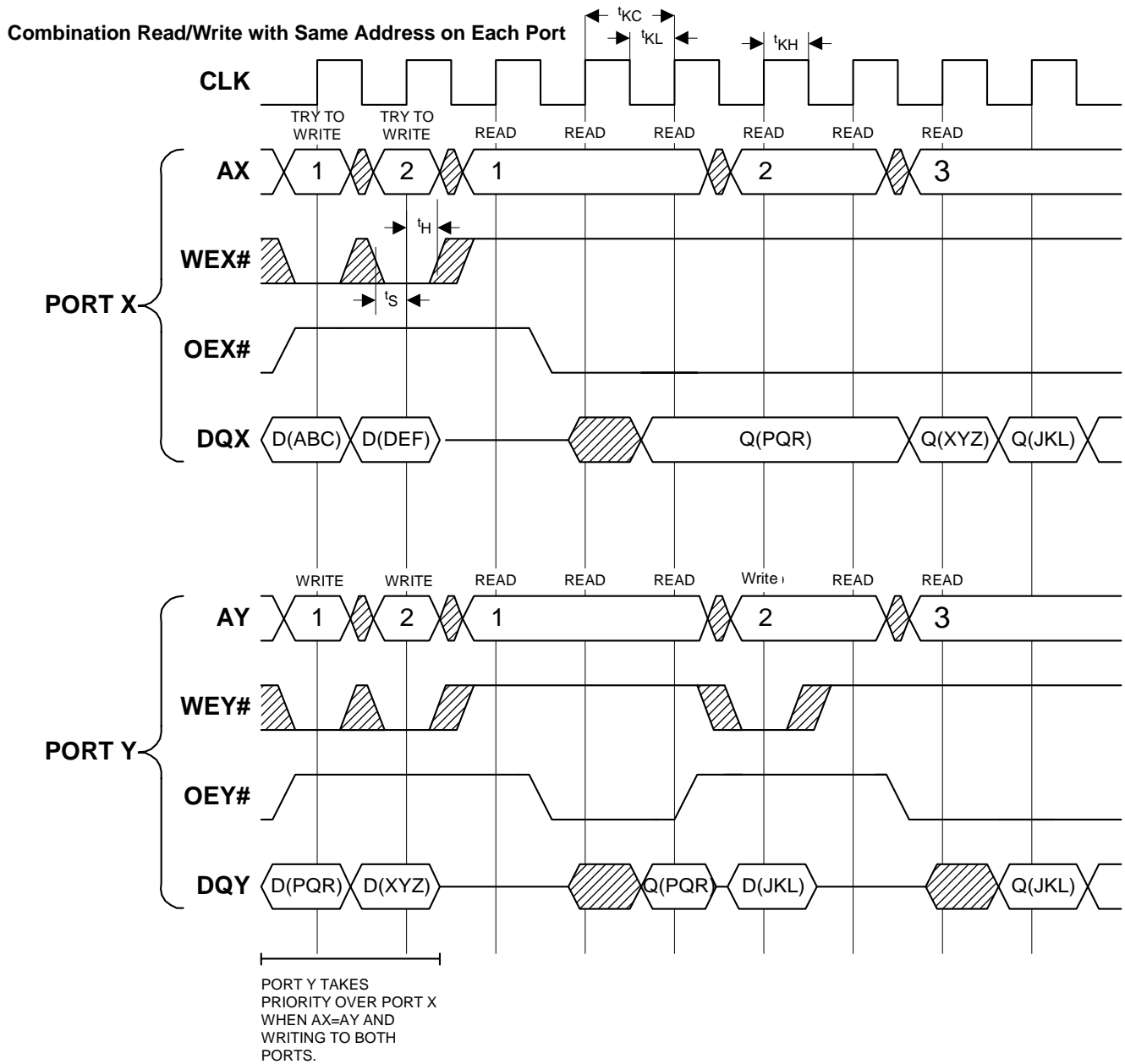

**Switching Waveforms (continued)<sup>[23]</sup>**

PTX# = PTY# = HIGH  
 D(Value) = Value is the input of the data port.  
 Q(Value) = Value is the output of the data port.

**Ordering Information**

Speed (MHz)	Ordering Code	Package Name	Package Type	Operating Range
100	CY7C1299A-100AC	A176	176-pin TQFP	Commercial
83	CY7C1299A-83AC			

**Package Diagram**

**176-lead Thin Quad Flat Pack (24 x 24 x 1.4 mm) A176**

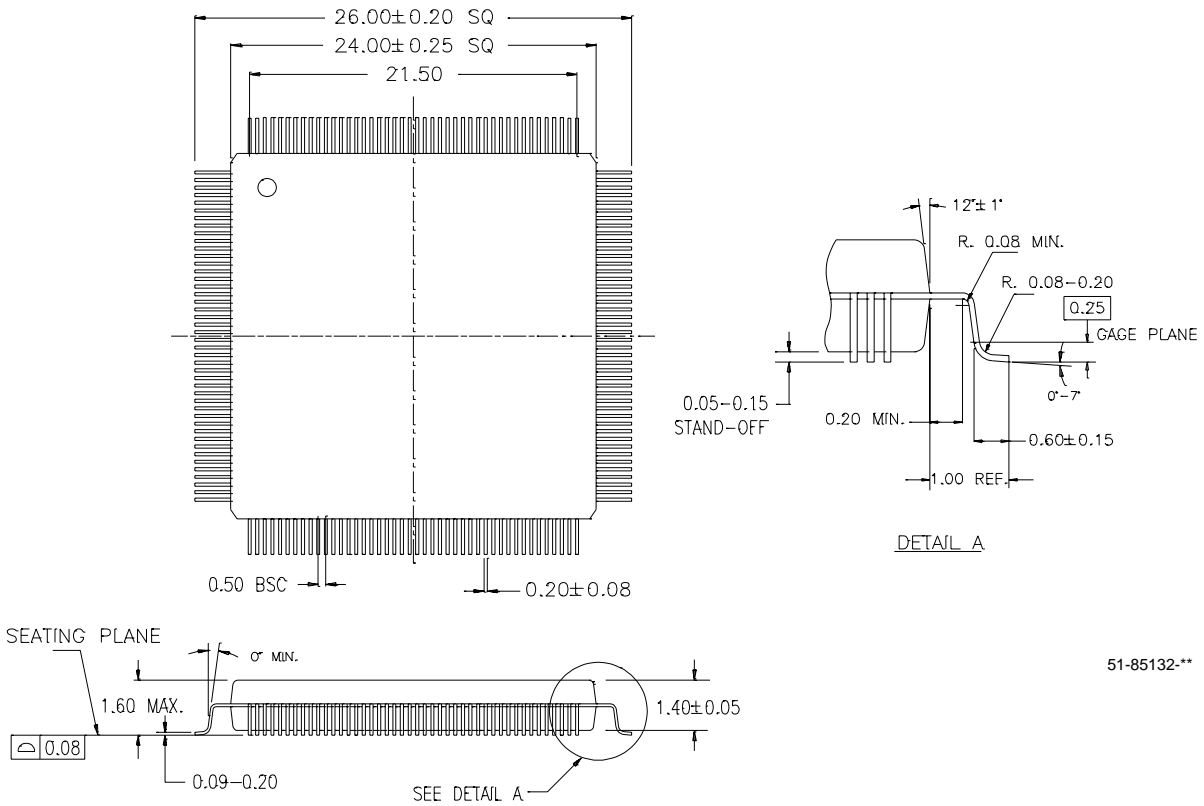

51-85132-\*\*

All product and company names mentioned in this document may be the trademarks of their respective holders.

**Document History Page**

<b>Document Title: CY7C1299A 32K x 36 Dual I/O Dual Address Synchronous SRAM</b>				
<b>Document Number: 38-05138</b>				
<b>REV.</b>	<b>ECN No.</b>	<b>Issue Date</b>	<b>Orig. of Change</b>	<b>Description of Change</b>
**	109817	10/16/01	NSL	New Data Sheet
*A	113014	04/09/02	KOM	Corrected I <sub>CC</sub> data to 500 and 430 mA from 350 and 300 mA. Updated Logic Block Diagram
*B	123151	01/18/03	RBI	Updated power-up requirements in AC Test Loads and Waveforms and Operating Range
*C	126196	05/14/03	APT	Corrected pinout on Package Description/Pin Definitions Corrected Cycle Description Truth Table Corrected Logic Block Diagram Added graph (d) in AC Test Loads and Waveforms