

FEATURES

- Plastic package has Underwriters Laboratory Flammability Classification 94V-0
- Low forward voltage drop
- High current capability, High reliability
- Low power loss, high efficiency
- High surge current capability
- High speed switching, Low leakage
- High temperature soldering guaranteed: 260°C/10 seconds at terminals
- Component in accordance to RoHS 2011/65/EU

MECHANICAL DATA

- Case: JEDEC DO-201AD molded plastic body
- Epoxy: UL94V-0 rate flame retardant
- Lead: Plated axial leads, solderable per MIL-STD-750, method 2026
- Polarity: Color band denotes cathode end
- Mounting Position: Any
- Weight: 0.042 ounce, 1.19 grams

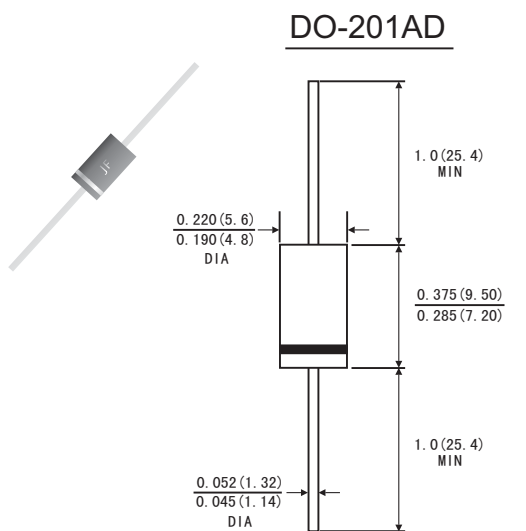

Dimensions in inches and (millimeters)

MAXIMUM RATINGS AND ELECTRICAL CHARACTERISTICS

(Rating at 25°C ambient temperature unless otherwise specified. Single phase, half wave, 60Hz, resistive or inductive load. For capacitive load, derate current by 20%.)

	Symbols	MUR 405	MUR 410	MUR 420	MUR 430	MUR 440	MUR 450	MUR 460	Units
Maximum Recurrent Peak Reverse Voltage	V_{RRM}	50	100	200	300	400	500	600	Volts
Maximum RMS Voltage	V_{RMS}	35	70	140	210	280	350	420	Volts
Maximum DC Blocking Voltage	V_{DC}	50	100	200	300	400	500	600	Volts
Maximum Average Forward Rectified Current 0.375"(9.5mm) lead length	$I_{(AV)}$	4.0							Amps
Peak Forward Surge Current 8.3ms single half sine-wave superimposed on rated load (JEDEC method)	I_{FSM}	150							Amps
Maximum Instantaneous Forward Voltage at 4.0 A	V_F	1.0			1.28			Volts	
Maximum DC Reverse Current at rated DC blocking voltage	$T_A=25^\circ\text{C}$	10.0							μA
	$T_A=100^\circ\text{C}$	50							
Maximum reverse recovery time (Note 1)	T_{rr}	45			60			ns	
Typical junction capacitance (Note 2)	C_J	80							pF
Operating junction and storage temperature range	T_J	-55 to +125							$^\circ\text{C}$
	T_{STG}	-55 to +150							

Note: 1. Test conditions: $I_F=0.5\text{A}$, $I_R=1.0\text{A}$, $I_{RR}=0.25\text{A}$.

2. Measured at 1MHz and applied reverse voltage of 4.0 Volts.

RATINGS AND CHARACTERISTIC CURVES MUR405 THRU MUR4100

FIG.1-TEST CIRCUIT DIAGRAM AND REVERSE RECOVERY TIME CHARACTERISTIC

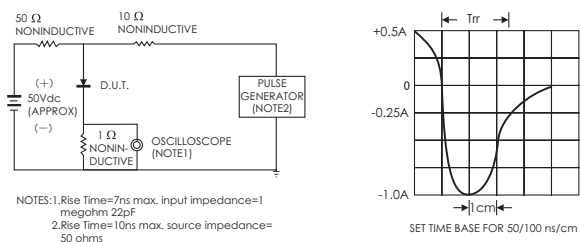

FIG.2-TYPICAL FORWARD CURRENT DERATING CURVE

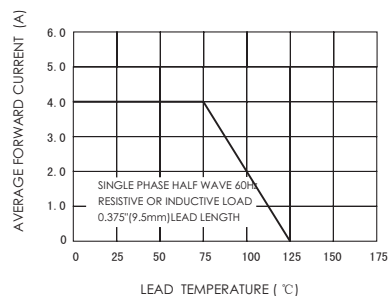

FIG.3-TYPICAL INSTANTANEOUS FORWARD CHARACTERISTICS

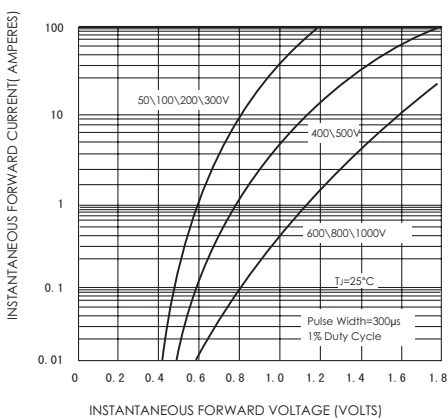

FIG.4-TYPICAL REVERSE CHARACTERISTICS

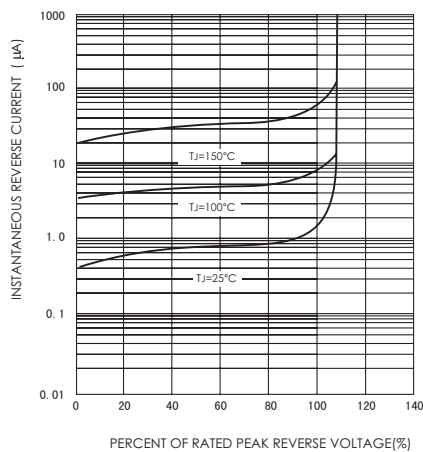

FIG.5-MAXIMUM NON-REPETITIVE FORWARD SURGE CURRENT

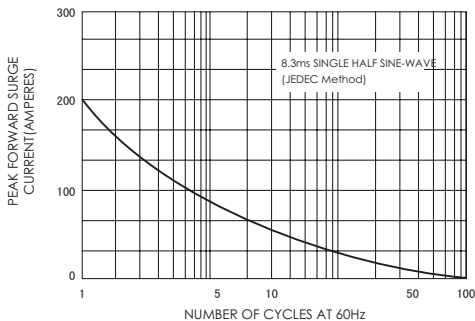

FIG.6-TYPICAL JUNCTION CAPACITANCE

